

SCHAUM'S
ouTlines

BASIC CIRCUIT ANALYSIS

Second Edition

JOHN O'MALLEY

The perfect aid for better grades!

Covers all course fundamentals—including op-amp circuits and PSpice

Teaches effective problem solving

700 problems solved
step-by-step

Ideal for independent
study!

MORE THAN
30 MILLION
SCHAUM'S
OUTLINES
COPIES
SOLD

Use with these courses: AC Power Analysis General Circuits

Electrical Engineering Circuit Analysis Introduction to Circuit Analysis AC & DC Circuits

Download more at [LearnDix.com](http://www.LearnDix.com)

SCHAUM'S OUTLINE OF

THEORY AND PROBLEMS

of

**BASIC CIRCUIT
ANALYSIS**

Second Edition

JOHN O'MALLEY, Ph.D.

*Professor of Electrical Engineering
University of Florida*

SCHAUM'S OUTLINE SERIES

McGRAW-HILL

*New York San Francisco Washington, D.C. Auckland Bogotá Caracas Lisbon
London Madrid Mexico City Milan Montreal New Delhi
San Juan Singapore Sydney Tokyo Toronto*

JOHN R. O'MALLEY is a Professor of Electrical Engineering at the University of Florida. He received a Ph.D. degree from the University of Florida and an LL.B. degree from Georgetown University. He is the author of two books on circuit analysis and two on the digital computer. He has been teaching courses in electric circuit analysis since 1959.

Schaum's Outline of Theory and Problems of
BASIC CIRCUIT ANALYSIS

Copyright © 1992, 1982 by The McGraw-Hill Companies Inc. All rights reserved. Printed in the United States of America. Except as permitted under the Copyright Act of 1976, no part of this publication may be reproduced or distributed in any form or by any means, or stored in a data base or retrieval system, without the prior written permission of the publisher.

9 10 11 12 13 14 15 16 17 18 19 20 PRS PRS 9

ISBN 0-07-047824-4

Sponsoring Editor: John Aliano
Production Supervisor: Louise Karam
Editing Supervisors: Meg Tobin, Maureen Walker

Library of Congress Cataloging-in-Publication Data

O'Malley, John.

Schaum's outline of theory and problems of basic circuit analysis

John O'Malley. -- 2nd ed.

p. c.m. (Schaum's outline series)

Includes index.

ISBN 0-07-047824-4

1. Electric circuits. 2. Electric circuit analysis. I. Title.

TK454.O46 1992

621.319'2 dc20

90-26615

McGraw-Hill

A Division of The McGraw-Hill Companies



*Dedicated to the loving memory of my brother
Norman Joseph O'Malley
Lawyer, engineer, and mentor*

This page intentionally left blank

Preface

Studying from this book will help both electrical technology and electrical engineering students learn circuit analysis with, it is hoped, less effort and more understanding. Since this book begins with the analysis of dc resistive circuits and continues to that of ac circuits, as do the popular circuit analysis textbooks, a student can, from the start, use this book as a supplement to a circuit analysis textbook.

The reader does not need a knowledge of differential or integral calculus even though this book has derivatives in the chapters on capacitors, inductors, and transformers, as is required for the voltage-current relations. The few problems with derivatives have clear physical explanations of them, and there is not a single integral anywhere in the book. Despite its lack of higher mathematics, this book can be very useful to an electrical engineering reader since most material in an electrical engineering circuit analysis course requires only a knowledge of algebra. Where there are different definitions in the electrical technology and engineering fields, as for capacitive reactances, phasors, and reactive power, the reader is cautioned and the various definitions are explained.

One of the special features of this book is the presentation of PSpice, which is a computer circuit analysis or simulation program that is suitable for use on personal computers (PCs). PSpice is similar to SPICE, which has become the standard for analog circuit simulation for the entire electronics industry. Another special feature is the presentation of operational-amplifier (op-amp) circuits. Both of these topics are new to this second edition. Another topic that has been added is the use of advanced scientific calculators to solve the simultaneous equations that arise in circuit analyses. Although this use requires placing the equations in matrix form, absolutely no knowledge of matrix algebra is required. Finally, there are many more problems involving circuits that contain dependent sources than there were in the first edition.

I wish to thank Dr. R. L. Sullivan, who, while I was writing this second edition, was Chairman of the Department of Electrical Engineering at the University of Florida. He nurtured an environment that made it conducive to the writing of books. Thanks are also due to my wife, Lois Anne, and my son Mathew for their constant support and encouragement without which I could not have written this second edition.

JOHN R. O'MALLEY

This page intentionally left blank

Contents

Chapter 1	BASIC CONCEPTS	1
	Digit Grouping	1
	International System of Units	1
	Electric Charge	1
	Electric Current	2
	Voltage	3
	Dependent Sources	4
	Power	5
	Energy	5
<hr/>		
Chapter 2	RESISTANCE	17
	Ohm's Law	17
	Resistivity	17
	Temperature Effects	18
	Resistors	19
	Resistor Power Absorption	19
	Nominal Values and Tolerances	19
	Color Code	20
	Open and Short Circuits	20
	Internal Resistance	20
<hr/>		
Chapter 3	SERIES AND PARALLEL DC CIRCUITS	31
	Branches, Nodes, Loops, Meshes, Series- and Parallel-Connected Components	31
	Kirchhoff's Voltage Law and Series DC Circuits	31
	Voltage Division	32
	Kirchhoff's Current Law and Parallel DC Circuits	32
	Current Division	34
	Kilohm-Milliampere Method	34
<hr/>		
Chapter 4	DC CIRCUIT ANALYSIS	54
	Cramer's Rule	54
	Calculator Solutions	55
	Source Transformations	56
	Mesh Analysis	56
	Loop Analysis	57
	Nodal Analysis	58
	Dependent Sources and Circuit Analysis	59
<hr/>		
Chapter 5	DC EQUIVALENT CIRCUITS, NETWORK THEOREMS, AND BRIDGE CIRCUITS	82
	Introduction	82
	Thévenin's and Norton's Theorems	82
	Maximum Power Transfer Theorem	84
	Superposition Theorem	84
	Millman's Theorem	84
	Y- Δ and Δ -Y Transformations	85
	Bridge Circuits	86

Chapter 6	OPERATIONAL-AMPLIFIER CIRCUITS	112
	Introduction	112
	Op-Amp Operation	112
	Popular Op-Amp Circuits	114
	Circuits with Multiple Operational Amplifiers	116
<hr/>		
Chapter 7	PSPICE DC CIRCUIT ANALYSIS	136
	Introduction	136
	Basic Statements	136
	Dependent Sources	138
	.DC and .PRINT Control Statements	139
	Restrictions	140
<hr/>		
Chapter 8	CAPACITORS AND CAPACITANCE	153
	Introduction	153
	Capacitance	153
	Capacitor Construction	153
	Total Capacitance	154
	Energy Storage	155
	Time-Varying Voltages and Currents	155
	Capacitor Current	156
	Single-Capacitor DC-Excited Circuits	156
	RC Timers and Oscillators	157
<hr/>		
Chapter 9	INDUCTORS, INDUCTANCE, AND PSPICE TRANSIENT ANALYSIS	174
	Introduction	174
	Magnetic Flux	174
	Inductance and Inductor Construction	175
	Inductor Voltage and Current Relation	175
	Total Inductance	176
	Energy Storage	177
	Single-Inductor DC-Excited Circuits	177
	PSpice Transient Analysis	177
<hr/>		
Chapter 10	SINUSOIDAL ALTERNATING VOLTAGE AND CURRENT	194
	Introduction	194
	Sine and Cosine Waves	195
	Phase Relations	197
	Average Value	198
	Resistor Sinusoidal Response	198
	Effective or RMS Values	198
	Inductor Sinusoidal Response	199
	Capacitor Sinusoidal Response	200
<hr/>		
Chapter 11	COMPLEX ALGEBRA AND PHASORS	217
	Introduction	217
	Imaginary Numbers	217
	Complex Numbers and the Rectangular Form	218
	Polar Form	219
	Phasors	221
<hr/>		
Chapter 12	BASIC AC CIRCUIT ANALYSIS, IMPEDANCE, AND ADMITTANCE	232
	Introduction	232
	Phasor-Domain Circuit Elements	232
	AC Series Circuit Analysis	234

	Impedance	234
	Voltage Division	236
	AC Parallel Circuit Analysis	237
	Admittance	238
	Current Division	239
<hr/>		
Chapter 13	MESH, LOOP, NODAL, AND PSPICE ANALYSES OF AC CIRCUITS	265
	Introduction	265
	Source Transformations	265
	Mesh and Loop Analyses	265
	Nodal Analysis	267
	PSpice AC Analysis	268
<hr/>		
Chapter 14	AC EQUIVALENT CIRCUITS, NETWORK THEOREMS, AND BRIDGE CIRCUITS	294
	Introduction	294
	Thévenin's and Norton's Theorems	294
	Maximum Power Transfer Theorem	295
	Superposition Theorem	295
	AC Y- Δ and Δ -Y Transformations	296
	AC Bridge Circuits	296
<hr/>		
Chapter 15	POWER IN AC CIRCUITS	324
	Introduction	324
	Circuit Power Absorption	324
	Wattmeters	325
	Reactive Power	326
	Complex Power and Apparent Power	326
	Power Factor Correction	327
<hr/>		
Chapter 16	TRANSFORMERS	349
	Introduction	349
	Right-Hand Rule	349
	Dot Convention	350
	The Ideal Transformer	350
	The Air-Core Transformer	352
	The Autotransformer	354
	PSpice and Transformers	356
<hr/>		
Chapter 17	THREE-PHASE CIRCUITS	384
	Introduction	384
	Subscript Notation	384
	Three-Phase Voltage Generation	384
	Generator Winding Connections	385
	Phase Sequence	386
	Balanced Y Circuit	387
	Balanced Δ Load	389
	Parallel Loads	390
	Power	391
	Three-Phase Power Measurements	391
	Unbalanced Circuits	393
	PSpice Analysis of Three-Phase Circuits	393
<hr/>		
	INDEX	415

This page intentionally left blank

Basic Concepts

DIGIT GROUPING

To make numbers easier to read, some international scientific committees have recommended the practice of separating digits into groups of three to the right and to the left of decimal points, as in 64 325.473 53. No separation is necessary, however, for just four digits, and they are preferably not separated. For example, either 4138 or 4 138 is acceptable, as is 0.1278 or 0.127 8, with 4138 and 0.1278 preferred. The international committees did not approve of the use of the comma to separate digits because in some countries the comma is used in place of the decimal point. This digit grouping is used throughout this book.

INTERNATIONAL SYSTEM OF UNITS

The *International System of Units (SI)* is the international measurement language. SI has nine base units, which are shown in Table 1-1 along with the unit symbols. Units of all other physical quantities are derived from these.

Table 1-1

Physical Quantity	Unit	Symbol
length	meter	m
mass	kilogram	kg
time	second	s
current	ampere	A
temperature	kelvin	K
amount of substance	mole	mol
luminous intensity	candela	cd
plane angle	radian	rad
solid angle	steradian	sr

There is a *decimal* relation, indicated by prefixes, among multiples and submultiples of each base unit. An SI prefix is a term attached to the beginning of an SI unit name to form either a decimal multiple or submultiple. For example, since “kilo” is the prefix for one thousand, a kilometer equals 1000 m. And because “micro” is the SI prefix for one-millionth, one microsecond equals 0.000 001 s.

The SI prefixes have symbols as shown in Table 1-2, which also shows the corresponding powers of 10. For most circuit analyses, only mega, kilo, milli, micro, nano, and pico are important. The proper location for a prefix symbol is in front of a unit symbol, as in km for kilometer and cm for centimeter.

ELECTRIC CHARGE

Scientists have discovered two kinds of electric charge: *positive* and *negative*. Positive charge is carried by subatomic particles called *protons*, and negative charge by subatomic particles called *electrons*. All amounts of charge are integer multiples of these elemental charges. Scientists have also found that charges

Table 1-2

Multiplier	Prefix	Symbol	Multiplier	Prefix	Symbol
10^{18}	exa	E	10^{-1}	deci	d
10^{15}	peta	P	10^{-2}	centi	c
10^{12}	tera	T	10^{-3}	milli	m
10^9	giga	G	10^{-6}	micro	μ
10^6	mega	M	10^{-9}	nano	n
10^3	kilo	k	10^{-12}	pico	p
10^2	hecto	h	10^{-15}	femto	f
10^1	deka	da	10^{-18}	atto	a

produce forces on each other: Charges of the same sign repel each other, but charges of opposite sign attract each other. Moreover, in an electric circuit there is *conservation of charge*, which means that the net electric charge remains constant—charge is neither created nor destroyed. (Electric components interconnected to form at least one closed path comprise an *electric circuit or network*.)

The charge of an electron or proton is much too small to be the basic charge unit. Instead, the SI unit of charge is the *coulomb* with unit symbol C. The quantity symbol is Q for a constant charge and q for a charge that varies with time. The charge of an electron is -1.602×10^{-19} C and that of a proton is 1.602×10^{-19} C. Put another way, the combined charge of 6.241×10^{18} electrons equals -1 C, and that of 6.241×10^{18} protons equals 1 C.

Each atom of matter has a positively charged nucleus consisting of protons and uncharged particles called *neutrons*. Electrons orbit around the nucleus under the attraction of the protons. For an undisturbed atom the number of electrons equals the number of protons, making the atom electrically neutral. But if an outer electron receives energy from, say, heat, it can gain enough energy to overcome the force of attraction of the protons and become a *free electron*. The atom then has more positive than negative charge and is a *positive ion*. Some atoms can also “capture” free electrons to gain a surplus of negative charge and become *negative ions*.

ELECTRIC CURRENT

Electric current results from the movement of electric charge. The SI unit of current is the *ampere* with unit symbol A. The quantity symbol is I for a constant current and i for a time-varying current. If a steady flow of 1 C of charge passes a given point in a conductor in 1 s, the resulting current is 1 A. In general,

$$I(\text{amperes}) = \frac{Q(\text{coulombs})}{t(\text{seconds})}$$

in which t is the quantity symbol for time.

Current has an associated direction. By convention the direction of current flow is in the direction of positive charge movement and opposite the direction of negative charge movement. In solids only free electrons move to produce current flow—the ions cannot move. But in gases and liquids, both positive and negative ions can move to produce current flow. Since electric circuits consist almost entirely of solids, only electrons produce current flow in almost all circuits. But this fact is seldom important in circuit analyses because the analyses are almost always at the current level and not the charge level.

In a circuit diagram each I (or i) usually has an associated arrow to indicate the *current reference direction*, as shown in Fig. 1-1. This arrow specifies the direction of positive current flow, but not necessarily the direction of actual flow. If, after calculations, I is found to be positive, then actual current flow is in the direction of the arrow. But if I is negative, current flow is in the opposite direction.

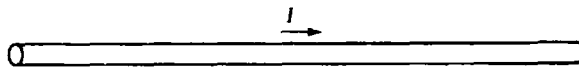

Fig. 1-1

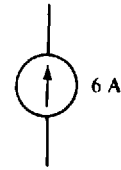

Fig. 1-2

A current that flows in only one direction all the time is a *direct current* (*dc*), while a current that alternates in direction of flow is an *alternating current* (*ac*). Usually, though, direct current refers only to a constant current, and alternating current refers only to a current that varies sinusoidally with time.

A *current source* is a circuit element that provides a specified current. Figure 1-2 shows the circuit diagram symbol for a current source. This source provides a current of 6 A in the direction of the arrow irrespective of the voltage (discussed next) across the source.

VOLTAGE

The concept of *voltage* involves work, which in turn involves force and distance. The SI unit of work is the *joule* with unit symbol J, the SI unit of force is the *newton* with unit symbol N, and of course the SI unit for distance is the meter with unit symbol m.

Work is required for moving an object against a force that opposes the motion. For example, lifting something against the force of gravity requires work. In general the work required in joules is the product of the force in newtons and the distance moved in meters:

$$W(\text{joules}) = F(\text{newtons}) \times s(\text{meters})$$

where W , F , and s are the quantity symbols for work, force, and distance, respectively.

Energy is the capacity to do work. One of its forms is *potential energy*, which is the energy a body has because of its position.

The *voltage difference* (also called the *potential difference*) between two points is the work in joules required to move 1 C of charge from one point to the other. The SI unit of voltage is the *volt* with unit symbol V. The quantity symbol is V or v , although E and e are also popular. In general,

$$V(\text{volts}) = \frac{W(\text{joules})}{Q(\text{coulombs})}$$

The voltage quantity symbol V sometimes has subscripts to designate the two points to which the voltage corresponds. If the letter a designates one point and b the other, and if W joules of work are required to move Q coulombs from point b to a , then $V_{ab} = W/Q$. Note that the first subscript is the point to which the charge is moved. The work quantity symbol sometimes also has subscripts as in $V_{ab} = W_{ab}/Q$.

If moving a positive charge from b to a (or a negative charge from a to b) actually requires work, the point a is positive with respect to point b . This is the *voltage polarity*. In a circuit diagram this voltage polarity is indicated by a positive sign (+) at point a and a negative sign (-) at point b , as shown in Fig. 1-3a for 6 V. Terms used to designate this voltage are a 6-V *voltage* or *potential rise* from b to a or, equivalently, a 6-V *voltage* or *potential drop* from a to b .

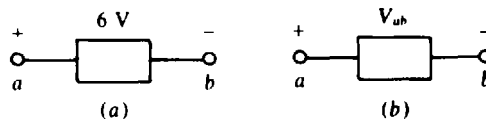

Fig. 1-3

If the voltage is designated by a quantity symbol as in Fig. 1-3*b*, the positive and negative signs are reference polarities and not necessarily actual polarities. Also, if subscripts are used, the positive polarity sign is at the point corresponding to the first subscript (a here) and the negative polarity sign is at the point corresponding to the second subscript (b here). If after calculations, V_{ab} is found to be positive, then point a is actually positive with respect to point b , in agreement with the reference polarity signs. But if V_{ab} is negative, the actual polarities are opposite those shown.

A constant voltage is called a *dc voltage*. And a voltage that varies sinusoidally with time is called an *ac voltage*.

A *voltage source*, such as a battery or generator, provides a voltage that, ideally, does not depend on the current flow through the source. Figure 1-4*a* shows the circuit symbol for a battery. This source provides a dc voltage of 12 V. This symbol is also often used for a dc voltage source that may not be a battery. Often, the + and - signs are not shown because, by convention, the long end-line designates the positive terminal and the short end-line the negative terminal. Another circuit symbol for a dc voltage source is shown in Fig. 1-4*b*. A battery uses chemical energy to move negative charges from the attracting positive terminal, where there is a surplus of protons, to the repulsing negative terminal, where there is a surplus of electrons. A voltage generator supplies this energy from mechanical energy that rotates a magnet past coils of wire.

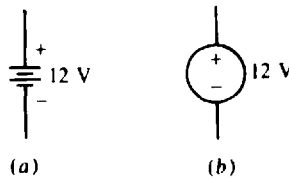

Fig. 1-4

DEPENDENT SOURCES

The sources of Figs. 1-2 and 1-4 are *independent* sources. An independent current source provides a certain current, and an independent voltage source provides a certain voltage, both independently of any other voltage or current. In contrast, a *dependent* source (also called a *controlled* source) provides a voltage or current that depends on a voltage or current elsewhere in a circuit. In a circuit diagram, a dependent source is designated by a diamond-shaped symbol. For an illustration, the circuit of Fig. 1-5 contains a dependent voltage source that provides a voltage of $5V_1$, which is five times the voltage V_1 that appears across a resistor elsewhere in the circuit. (The resistors shown are discussed in the next chapter.) There are four types of dependent sources: a *voltage-controlled voltage source* as shown in Fig. 1-5, a *current-controlled voltage source*, a *voltage-controlled current source*, and a *current-controlled current source*. Dependent sources are rarely separate physical components. But they are important because they occur in *models* of electronic components such as operational amplifiers and transistors.

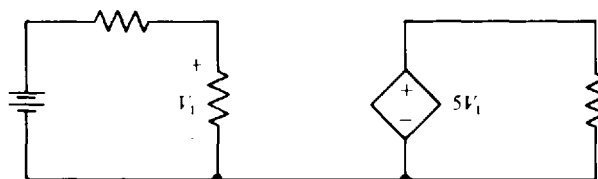

Fig. 1-5

POWER

The *rate* at which something either absorbs or produces energy is the *power* absorbed or produced. A source of energy produces or delivers power and a load absorbs it. The SI unit of power is the *watt* with unit symbol W. The quantity symbol is P for constant power and p for time-varying power. If 1 J of work is either absorbed or delivered at a constant rate in 1 s, the corresponding power is 1 W. In general,

$$P(\text{watts}) = \frac{W(\text{joules})}{t(\text{seconds})}$$

The power *absorbed* by an electric component is the product of voltage and current if the current reference arrow is into the positively referenced terminal, as shown in Fig. 1-6:

$$P(\text{watts}) = V(\text{volts}) \times I(\text{amperes})$$

Such references are called *associated references*. (The term *passive sign convention* is often used instead of "associated references.") If the references are not associated (the current arrow is into the negatively referenced terminal), the power absorbed is $P = -VI$.

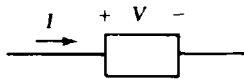

Fig. 1-6

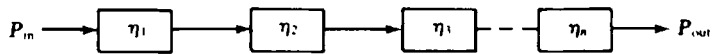

Fig. 1-7

If the calculated P is positive with either formula, the component actually *absorbs* power. But if P is negative, the component *produces* power—it is a *source* of electric energy.

The power output rating of motors is usually expressed in a power unit called the *horsepower* (hp) even though this is not an SI unit. The relation between horsepower and watts is $1 \text{ hp} = 745.7 \text{ W}$.

Electric motors and other systems have an *efficiency* (η) of operation defined by

$$\text{Efficiency} = \frac{\text{power output}}{\text{power input}} \times 100\% \quad \text{or} \quad \eta = \frac{P_{\text{out}}}{P_{\text{in}}} \times 100\%$$

Efficiency can also be based on work output divided by work input. In calculations, efficiency is usually expressed as a decimal fraction that is the percentage divided by 100.

The overall efficiency of a cascaded system as shown in Fig. 1-7 is the product of the individual efficiencies:

$$\frac{P_{\text{out}}}{P_{\text{in}}} = \eta_1 \eta_2 \eta_3 \cdots \eta_n$$

ENERGY

Electric energy used or produced is the product of the electric power input or output and the time over which this input or output occurs:

$$W(\text{joules}) = P(\text{watts}) \times t(\text{seconds})$$

Electric energy is what customers purchase from electric utility companies. These companies do not use the joule as an energy unit but instead use the much larger and more convenient *kilowatt-hour* (kWh) even though it is not an SI unit. The number of kilowatt-hours consumed equals the product of the power absorbed in kilowatts and the time in hours over which it is absorbed:

$$W(\text{kilowatt-hours}) = P(\text{kilowatts}) \times t(\text{hours})$$

Solved Problems

1.1 Find the charge in coulombs of (a) 5.31×10^{20} electrons, and (b) 2.9×10^{22} protons.

(a) Since the charge of an electron is -1.602×10^{-19} C, the total charge is

$$5.31 \times 10^{20} \frac{\text{electrons}}{\text{electron}} \times \frac{-1.602 \times 10^{-19} \text{ C}}{1 \text{ electron}} = -85.1 \text{ C}$$

(b) Similarly, the total charge is

$$2.9 \times 10^{22} \frac{\text{protons}}{\text{proton}} \times \frac{1.602 \times 10^{-19} \text{ C}}{1 \text{ proton}} = 4.65 \text{ kC}$$

1.2 How many protons have a combined charge of 6.8 pC?

Because the combined charge of 6.241×10^{18} protons is 1 C, the number of protons is

$$6.8 \times 10^{-12} \text{ C} \times \frac{6.241 \times 10^{18} \text{ protons}}{1 \text{ C}} = 4.24 \times 10^7 \text{ protons}$$

1.3 Find the current flow through a light bulb from a steady movement of (a) 60 C in 4 s, (b) 15 C in 2 min, and (c) 10^{22} electrons in 1 h.

Current is the rate of charge movement in coulombs per second. So,

$$(a) I = \frac{Q}{t} = \frac{60 \text{ C}}{4 \text{ s}} = 15 \text{ C/s} = 15 \text{ A}$$

$$(b) I = \frac{15 \text{ C}}{2 \frac{\text{min}}{60 \text{ s}}} = 0.125 \text{ C/s} = 0.125 \text{ A}$$

$$(c) I = \frac{10^{22} \text{ electrons}}{1 \text{ h}} \times \frac{1 \text{ h}}{3600 \text{ s}} \times \frac{-1.602 \times 10^{-19} \text{ C}}{1 \text{ electron}} = -0.445 \text{ C/s} = -0.445 \text{ A}$$

The negative sign in the answer indicates that the current flows in a direction opposite that of electron movement. But this sign is unimportant here and can be omitted because the problem statement does not specify the direction of electron movement.

1.4 Electrons pass to the right through a wire cross section at the rate of 6.4×10^{21} electrons per minute. What is the current in the wire?

Because current is the rate of charge movement in coulombs per second,

$$I = \frac{6.4 \times 10^{21} \text{ electrons}}{1 \text{ min}} \times \frac{-1 \text{ C}}{6.241 \times 10^{18} \text{ electrons}} \times \frac{1 \text{ min}}{60 \text{ s}} = -17.1 \text{ C/s} = -17.1 \text{ A}$$

The negative sign in the answer indicates that the current is to the left, opposite the direction of electron movement.

1.5 In a liquid, negative ions, each with a single surplus electron, move to the left at a steady rate of 2.1×10^{20} ions per minute and positive ions, each with two surplus protons, move to the right at a steady rate of 4.8×10^{19} ions per minute. Find the current to the right.

The negative ions moving to the left and the positive ions moving to the right both produce a current to the right because current flow is in a direction opposite that of negative charge movement and the same as that of positive charge movement. For a current to the right, the movement of electrons to the left is a

negative movement. Also, each positive ion, being doubly ionized, has double the charge of a proton. So,

$$I = - \frac{2.1 \times 10^{20} \text{ electrons}}{1 \text{ min}} \times \frac{-1.602 \times 10^{-19} \text{ C}}{1 \text{ electron}} \times \frac{1 \text{ min}}{60 \text{ s}} + \frac{2 \times 4.8 \times 10^{19} \text{ protons}}{1 \text{ min}} \times \frac{1.602 \times 10^{-19} \text{ C}}{1 \text{ proton}} \times \frac{1 \text{ min}}{60 \text{ s}} = 0.817 \text{ A}$$

- 1.6** Will a 10-A fuse blow for a steady rate of charge flow through it of 45 000 C/h?

The current is

$$\frac{45\,000 \text{ C}}{1 \text{ h}} \times \frac{1 \text{ h}}{3600 \text{ s}} = 12.5 \text{ A}$$

which is more than the 10-A rating. So the fuse will blow.

- 1.7** Assuming a steady current flow through a switch, find the time required for (a) 20 C to flow if the current is 15 mA, (b) 12 μC to flow if the current is 30 pA, and (c) 2.58×10^{15} electrons to flow if the current is -64.2 nA .

Since $I = Q/t$ solved for t is $t = Q/I$,

$$(a) \quad t = \frac{20}{15 \times 10^{-3}} = 1.33 \times 10^3 \text{ s} = 22.2 \text{ min}$$

$$(b) \quad t = \frac{12 \times 10^{-6}}{30 \times 10^{-12}} = 4 \times 10^5 \text{ s} = 111 \text{ h}$$

$$(c) \quad t = \frac{2.58 \times 10^{15} \text{ electrons}}{-64.2 \times 10^{-9} \text{ A}} \times \frac{-1 \text{ C}}{6.241 \times 10^{18} \text{ electrons}} = 6.44 \times 10^3 \text{ s} = 1.79 \text{ h}$$

- 1.8** The total charge that a battery can deliver is usually specified in ampere-hours (Ah). An ampere-hour is the quantity of charge corresponding to a current flow of 1 A for 1 h. Find the number of coulombs corresponding to 1 Ah.

Since from $Q = It$, 1 C is equal to one ampere second (As),

$$Q = 1 \text{ Ah} \times \frac{3600 \text{ s}}{1 \text{ h}} = 3600 \text{ As} = 3600 \text{ C}$$

- 1.9** A certain car battery is rated at 700 Ah at 3.5 A, which means that the battery can deliver 3.5 A for approximately $700/3.5 = 200$ h. However, the larger the current, the less the charge that can be drawn. How long can this battery deliver 2 A?

The time that the current can flow is approximately equal to the ampere-hour rating divided by the current:

$$t = \frac{700 \text{ Ah}}{2 \text{ A}} = 350 \text{ h}$$

Actually, the battery can deliver 2 A for longer than 350 h because the ampere-hour rating for this smaller current is greater than that for 3.5 A.

- 1.10** Find the average drift velocity of electrons in a No. 14 AWG copper wire carrying a 10-A current, given that copper has 1.38×10^{24} free electrons per cubic inch and that the cross-sectional area of No. 14 AWG wire is $3.23 \times 10^{-3} \text{ in}^2$.

The average drift velocity (v) equals the current divided by the product of the cross-sectional area and the electron density:

$$v = \frac{10 \text{ C}}{1 \text{ s}} \times \frac{1}{3.23 \times 10^{-3} \text{ m}^2} \times \frac{1 \text{ m}^3}{1.38 \times 10^{24} \text{ electrons}} \times \frac{0.0254 \text{ m}}{1 \text{ m}} \times \frac{1 \text{ electron}}{1.602 \times 10^{-19} \text{ C}}$$

$$= -3.56 \times 10^{-4} \text{ m s}^{-1}$$

The negative sign in the answer indicates that the electrons move in a direction opposite that of current flow. Notice the low velocity. An electron travels only 1.28 m in 1 h, on the average, even though the electric impulses produced by the electron movement travel at near the speed of light ($2.998 \times 10^8 \text{ m s}^{-1}$).

1.11 Find the work required to lift a 4500-kg elevator a vertical distance of 50 m.

The work required is the product of the distance moved and the force needed to overcome the weight of the elevator. Since this weight in newtons is 9.8 times the mass in kilograms,

$$W = Fs = (9.8 \times 4500)(50) \text{ J} = 2.2 \text{ MJ}$$

1.12 Find the potential energy in joules gained by a 180-lb man in climbing a 6-ft ladder.

The potential energy gained by the man equals the work he had to do to climb the ladder. The force involved is his weight, and the distance is the height of the ladder. The conversion factor from weight in pounds to a force in newtons is $1 \text{ N} = 0.225 \text{ lb}$. Thus,

$$W = 180 \text{ lb} \times 6 \text{ ft} \times \frac{1 \text{ N}}{0.225 \text{ lb}} \times \frac{12 \text{ in}}{1 \text{ ft}} \times \frac{0.0254 \text{ m}}{1 \text{ in}} = 1.46 \times 10^3 \text{ Nm} = 1.46 \text{ kJ}$$

1.13 How much chemical energy must a 12-V car battery expend in moving 8.93×10^{20} electrons from its positive terminal to its negative terminal?

The appropriate formula is $W = QV$. Although the signs of Q and V are important, obviously here the product of these quantities must be positive because energy is required to move the electrons. So, the easiest approach is to ignore the signs of Q and V . Or, if signs are used, V is negative because the charge moves to a more negative terminal, and of course Q is negative because electrons have a negative charge. Thus,

$$W = QV = 8.93 \times 10^{20} \text{ electrons} \times (-12 \text{ V}) \times \frac{-1 \text{ C}}{6.241 \times 10^{18} \text{ electrons}} = 1.72 \times 10^3 \text{ J} = 1.72 \text{ kJ}$$

1.14 If moving 16 C of positive charge from point b to point a requires 0.8 J, find V_{ab} , the voltage drop from point a to point b .

$$V_{ab} = \frac{W_{ab}}{Q} = \frac{0.8}{16} = 0.05 \text{ V}$$

1.15 In moving from point a to point b , 2×10^{19} electrons do 4 J of work. Find V_{ab} , the voltage drop from point a to point b .

Work done *by* the electrons is equivalent to *negative* work done *on* the electrons, and voltage depends on work done *on* charge. So, $W_{ba} = -4 \text{ J}$, but $W_{ab} = -W_{ba} = 4 \text{ J}$. Thus,

$$V_{ab} = \frac{W_{ab}}{Q} = \frac{4 \text{ J}}{2 \times 10^{19} \text{ electrons}} \times \frac{6.241 \times 10^{18} \text{ electrons}}{-1 \text{ C}} = -1.25 \text{ J C}^{-1} = -1.25 \text{ V}$$

The negative sign indicates that there is a voltage rise from a to b instead of a voltage drop. In other words, point b is more positive than point a .

- 1.16** Find V_{ab} , the voltage drop from point a to point b , if 24 J are required to move charges of (a) 3 C, (b) -4 C, and (c) 20×10^{19} electrons from point a to point b .

If 24 J are required to move the charges from point a to point b , then -24 J are required to move them from point b to point a . In other words, $W_{ab} = -24$ J. So,

$$(a) \quad V_{ab} = \frac{W_{ab}}{Q} = \frac{-24}{3} = -8 \text{ V}$$

The negative sign in the answer indicates that point a is more negative than point b — there is a voltage rise from a to b .

$$(b) \quad V_{ab} = \frac{W_{ab}}{Q} = \frac{-24}{-4} = 6 \text{ V}$$

$$(c) \quad V_{ab} = \frac{W_{ab}}{Q} = \frac{-24 \text{ J}}{20 \times 10^{19} \text{ electrons}} \times \frac{6.241 \times 10^{18} \text{ electrons}}{-1 \text{ C}} = 0.749 \text{ V}$$

- 1.17** Find the energy stored in a 12-V car battery rated at 650 Ah.

From $W = QV$ and the fact that $1 \text{ As} = 1 \text{ C}$,

$$W = 650 \text{ Ah} \times \frac{3600 \text{ s}}{1 \text{ h}} \times 12 \text{ V} = 2.34 \times 10^6 \text{ As} \times 12 \text{ V} = 28.08 \text{ MJ}$$

- 1.18** Find the voltage drop across a light bulb if a 0.5-A current flowing through it for 4 s causes the light bulb to give off 240 J of light and heat energy.

Since the charge that flows is $Q = It = 0.5 \times 4 = 2 \text{ C}$,

$$V = \frac{W}{Q} = \frac{240}{2} = 120 \text{ V}$$

- 1.19** Find the average input power to a radio that consumes 3600 J in 2 min.

$$P = \frac{W}{t} = \frac{3600 \text{ J}}{2 \text{ min}} \times \frac{1 \text{ min}}{60 \text{ s}} = 30 \text{ J s} = 30 \text{ W}$$

- 1.20** How many joules does a 60-W light bulb consume in 1 h?

From rearranging $P = W/t$ and from the fact that $1 \text{ Ws} = 1 \text{ J}$,

$$W = Pt = 60 \text{ W} \times 1 \text{ h} \times \frac{3600 \text{ s}}{1 \text{ h}} = 216\,000 \text{ Ws} = 216 \text{ kJ}$$

- 1.21** How long does a 100-W light bulb take to consume 13 kJ?

From rearranging $P = W/t$,

$$t = \frac{W}{P} = \frac{13\,000}{100} = 130 \text{ s}$$

- 1.22** How much power does a stove element absorb if it draws 10 A when connected to a 115-V line?

$$P = VI = 115 \times 10 \text{ W} = 1.15 \text{ kW}$$

1.23 What current does a 1200-W toaster draw from a 120-V line?

From rearranging $P = VI$,

$$I = \frac{P}{V} = \frac{1200}{120} = 10 \text{ A}$$

1.24 Figure 1-8 shows a circuit diagram of a voltage source of V volts connected to a current source of I amperes. Find the power absorbed by the voltage source for

- (a) $V = 2 \text{ V}$, $I = 4 \text{ A}$
 (b) $V = 3 \text{ V}$, $I = -2 \text{ A}$
 (c) $V = -6 \text{ V}$, $I = -8 \text{ A}$

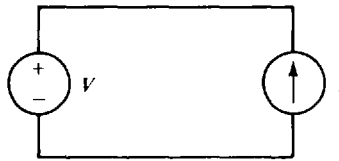

Fig. 1-8

Because the reference arrow for I is into the positively referenced terminal for V , the current and voltage references for the voltage source are associated. This means that there is a positive sign (or the absence of a negative sign) in the relation between power absorbed and the product of voltage and current: $P = VI$. With the given values inserted,

- (a) $P = VI = 2 \times 4 = 8 \text{ W}$
 (b) $P = VI = 3 \times (-2) = -6 \text{ W}$

The negative sign for the power indicates that the voltage source delivers rather than absorbs power.

- (c) $P = VI = -6 \times (-8) = 48 \text{ W}$

1.25 Figure 1-9 shows a circuit diagram of a current source of I amperes connected to an independent voltage source of 8 V and a current-controlled dependent voltage source that provides a voltage that in volts is equal to two times the current flow in amperes through it. Determine the power P_1 absorbed by the independent voltage source and the power P_2 absorbed by the dependent voltage source for (a) $I = 4 \text{ A}$, (b) $I = 5 \text{ mA}$, and (c) $I = -3 \text{ A}$.

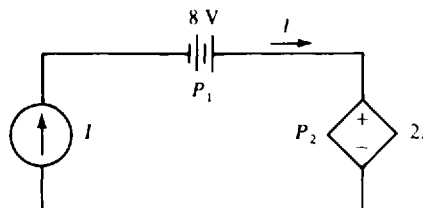

Fig. 1-9

Because the reference arrow for I is directed into the negative terminal of the 8-V source, the power-absorbed formula has a negative sign: $P_1 = -8I$. For the dependent source, though, the voltage and current references are associated, and so the power absorbed is $P_2 = 2I(I) = 2I^2$. With the given current values inserted,

- (a) $P_1 = -8(4) = -32 \text{ W}$ and $P_2 = 2(4)^2 = 32 \text{ W}$. The negative power for the independent source indicates that it is producing power instead of absorbing it.
- (b) $P_1 = -8(5 \times 10^{-3}) = -40 \times 10^{-3} \text{ W} = -40 \text{ mW}$
 $P_2 = 2(5 \times 10^{-3})^2 = 50 \times 10^{-6} \text{ W} = 50 \mu\text{W}$
- (c) $P_1 = -8(-3) = 24 \text{ W}$ and $P_2 = 2(-3)^2 = 18 \text{ W}$. The power absorbed by the dependent source remains positive because although the current reversed direction, the polarity of the voltage did also, and so the actual current flow is still into the actual positive terminal.

1.26 Calculate the power absorbed by each component in the circuit of Fig. 1-10.

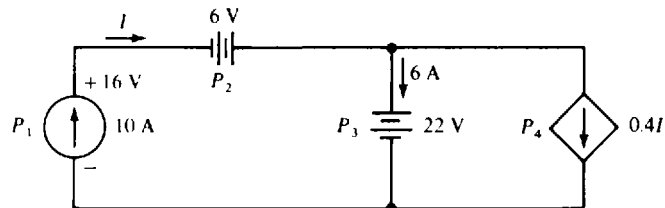

Fig. 1-10

Since for the 10-A current source the current flows out of the positive terminal, the power it absorbs is $P_1 = -16(10) = -160 \text{ W}$. The negative sign indicates that this source is not absorbing power but rather is delivering power to other components in the circuit. For the 6-V source, the 10-A current flows into the negative terminal, and so $P_2 = -6(10) = -60 \text{ W}$. For the 22-V source, $P_3 = 22(6) = 132 \text{ W}$. Finally, the dependent source provides a current of $0.4(10) = 4 \text{ A}$. This current flows into the positive terminal since this source also has 22 V, positive at the top, across it. Consequently, $P_4 = 22(4) = 88 \text{ W}$. Observe that

$$P_1 + P_2 + P_3 + P_4 = -160 - 60 + 132 + 88 = 0 \text{ W}$$

The sum of 0 W indicates that in this circuit the power absorbed by components is equal to the power delivered. This result is true for every circuit.

1.27 How long can a 12-V car battery supply 250 A to a starter motor if the battery has $4 \times 10^6 \text{ J}$ of chemical energy that can be converted to electric energy?

The best approach is to use $t = W/P$. Here,

$$P = VI = 12 \times 250 = 3000 \text{ W}$$

And so

$$t = \frac{W}{P} = \frac{4 \times 10^6}{3000} = 1333.33 \text{ s} = 22.2 \text{ min}$$

1.28 Find the current drawn from a 115-V line by a dc electric motor that delivers 1 hp. Assume 100 percent efficiency of operation.

From rearranging $P = VI$ and from the fact that $1 \text{ W/V} = 1 \text{ A}$,

$$I = \frac{P}{V} = \frac{1 \text{ hp}}{115 \text{ V}} \times \frac{745.7 \text{ W}}{1 \text{ hp}} = 6.48 \text{ W/V} = 6.48 \text{ A}$$

- 1.29** Find the efficiency of operation of an electric motor that delivers 1 hp while absorbing an input of 900 W.

$$\eta = \frac{P_{\text{out}}}{P_{\text{in}}} \times 100\% = \frac{1 \text{ hp}}{900 \cancel{\text{ W}}} \times \frac{745.7 \cancel{\text{ W}}}{1 \text{ hp}} \times 100\% = 82.9\%$$

- 1.30** What is the operating efficiency of a fully loaded 2-hp dc electric motor that draws 19 A at 100 V? (The power rating of a motor specifies the output power and not the input power.)

Since the input power is

$$P_{\text{in}} = VI = 100 \times 19 = 1900 \text{ W}$$

the efficiency is

$$\eta = \frac{P_{\text{out}}}{P_{\text{in}}} \times 100\% = \frac{2 \text{ hp}}{1900 \cancel{\text{ W}}} \times \frac{745.7 \cancel{\text{ W}}}{1 \text{ hp}} \times 100\% = 78.5\%$$

- 1.31** Find the input power to a fully loaded 5-hp motor that operates at 80 percent efficiency.

For almost all calculations, the efficiency is better expressed as a decimal fraction that is the percentage divided by 100, which is 0.8 here. Then from $\eta = P_{\text{out}}/P_{\text{in}}$,

$$P_{\text{in}} = \frac{P_{\text{out}}}{\eta} = \frac{5 \text{ hp}}{0.8} \times \frac{745.7 \text{ W}}{1 \text{ hp}} = 4.66 \text{ kW}$$

- 1.32** Find the current drawn by a dc electric motor that delivers 2 hp while operating at 85 percent efficiency from a 110-V line.

From $P_{\text{in}} = VI = P_{\text{out}}/\eta$,

$$I = \frac{P_{\text{out}}}{\eta V} = \frac{2 \text{ hp}}{0.85 \times 110 \text{ V}} \times \frac{745.7 \text{ W}}{1 \text{ hp}} = 15.95 \text{ A}$$

- 1.33** Maximum received solar power is about 1 kW m². If solar panels, which convert solar energy to electric energy, are 13 percent efficient, how many square meters of solar cell panels are needed to supply the power to a 1600-W toaster?

The power from each square meter of solar panels is

$$P_{\text{out}} = \eta P_{\text{in}} = 0.13 \times 1000 = 130 \text{ W}$$

So, the total solar panel area needed is

$$\text{Area} = \frac{1600 \cancel{\text{ W}}}{130 \cancel{\text{ W}}} \times 1 \text{ m}^2 = 12.3 \text{ m}^2$$

- 1.34** What horsepower must an electric motor develop to pump water up 40 ft at the rate of 2000 gallons per hour (gal/h) if the pumping system operates at 80 percent efficiency?

One way to solve for the power is to use the work done by the pump in 1 h, which is the weight of the water lifted in 1 h times the height through which it is lifted. This work divided by the time taken is the power output of the pumping system. And this power divided by the efficiency is the input power to the pumping system, which is the required output power of the electric motor. Some needed data are that 1 gal of water weighs 8.33 lb, and that 1 hp = 550 (ft · lb) / s. Thus,

$$P = \frac{2000 \cancel{\text{ gal}}}{1 \cancel{\text{ h}}} \times 40 \cancel{\text{ ft}} \times \frac{1}{0.8} \times \frac{1 \cancel{\text{ h}}}{3600 \cancel{\text{ s}}} \times \frac{8.33 \cancel{\text{ lb}}}{1 \cancel{\text{ gal}}} \times \frac{1 \text{ hp}}{550 \cancel{\text{ (ft} \cdot \text{ lb) / s}}} = 0.42 \text{ hp}$$

- 1.35** Two systems are in cascade. One operates with an efficiency of 75 percent and the other with an efficiency of 85 percent. If the input power is 5 kW, what is the output power?

$$P_{\text{out}} = \eta_1 \eta_2 P_{\text{in}} = 0.75(0.85)(5000) \text{ W} = 3.19 \text{ kW}$$

- 1.36** Find the conversion relation between kilowatthours and joules.

The approach here is to convert from kilowatthours to watt-seconds, and then use the fact that $1 \text{ J} = 1 \text{ Ws}$:

$$1 \text{ kWh} = 1000 \text{ W} \times 3600 \text{ s} = 3.6 \times 10^6 \text{ Ws} = 3.6 \text{ MJ}$$

- 1.37** For an electric rate of 7¢ kilowatthour, what does it cost to leave a 60-W light bulb on for 8 h?

The cost equals the total energy used times the cost per energy unit:

$$\text{Cost} = 60 \text{ W} \times 8 \text{ h} \times \frac{1 \text{ kWh}}{1000 \text{ Wh}} \times \frac{7\text{¢}}{1 \text{ kWh}} = 3.36\text{¢}$$

- 1.38** An electric motor delivers 5 hp while operating with an efficiency of 85 percent. Find the cost for operating it continuously for one day (d) if the electric rate is 6¢ kilowatthour.

The total energy used is the output power times the time of operation, all divided by the efficiency. The product of this energy and the electric rate is the total cost:

$$\text{Cost} = 5 \text{ hp} \times 1 \text{ d} \times \frac{1}{0.85} \times \frac{6\text{¢}}{1 \text{ kWh}} \times \frac{0.7457 \text{ kW}}{1 \text{ hp}} \times \frac{24 \text{ h}}{1 \text{ d}} = 632\text{¢} = \$6.32$$

Supplementary Problems

- 1.39** Find the charge in coulombs of (a) 6.28×10^{21} electrons and (b) 8.76×10^{20} protons.
Ans. (a) -1006 C , (b) 140 C
- 1.40** How many electrons have a total charge of -4 nC ?
Ans. 2.5×10^{10} electrons
- 1.41** Find the current flow through a switch from a steady movement of (a) 90 C in 6 s , (b) 900 C in 20 min , and (c) 4×10^{23} electrons in 5 h .
Ans. (a) 15 A , (b) 0.75 A , (c) 3.56 A
- 1.42** A capacitor is an electric circuit component that stores electric charge. If a capacitor charges at a steady rate to 10 mC in 0.02 ms , and if it discharges in $1 \mu\text{s}$ at a steady rate, what are the magnitudes of the charging and discharging currents?
Ans. 500 A , $10\,000 \text{ A}$
- 1.43** In a gas, if doubly ionized negative ions move to the right at a steady rate of 3.62×10^{20} ions per minute and if singly ionized positive ions move to the left at a steady rate of 5.83×10^{20} ions per minute, find the current to the right.
Ans. -3.49 A
- 1.44** Find the shortest time that 120 C can flow through a 20-A circuit breaker without tripping it.
Ans. 6 s

- 1.45** If a steady current flows to a capacitor, find the time required for the capacitor to (a) charge to 2.5 mC if the current is 35 mA, (b) charge to 36 pC if the current is 18 μA , and (c) store 9.36×10^{17} electrons if the current is 85.6 nA.
Ans. (a) 71.4 ms, (b) 2 μs , (c) 20.3 d
- 1.46** How long can a 4.5-Ah, 1.5-V flashlight battery deliver 100 mA?
Ans. 45 h
- 1.47** Find the potential energy in joules lost by a 1.2-lb book in falling off a desk that is 31 in high.
Ans. 4.2 J
- 1.48** How much chemical energy must a 1.25-V flashlight battery expend in producing a current flow of 130 mA for 5 min?
Ans. 48.8 J
- 1.49** Find the work done by a 9-V battery in moving 5×10^{20} electrons from its positive terminal to its negative terminal.
Ans. 721 J
- 1.50** Find the total energy available from a rechargeable 1.25-V flashlight battery with a 1.2-Ah rating.
Ans. 5.4 kJ
- 1.51** If all the energy in a 9-V transistor radio battery rated at 0.392 Ah is used to lift a 150-lb man, how high in feet will he be lifted?
Ans. 62.5 ft
- 1.52** If a charge of -4 C in moving from point a to point b gives up 20 J of energy, what is V_{ab} ?
Ans. -5 V
- 1.53** Moving 6.93×10^{19} electrons from point b to point a requires 98 J of work. Find V_{ab} .
Ans. -8.83 V
- 1.54** How much power does an electric clock require if it draws 27.3 mA from a 110-V line?
Ans. 3 W
- 1.55** Find the current drawn by a 1000-W steam iron from a 120-V line.
Ans. 8.33 A
- 1.56** For the circuit of Fig. 1-11, find the power absorbed by the current source for (a) $V = 4$ V, $I = 2$ mA; (b) $V = -50$ V, $I = -150$ μA ; (c) $V = 10$ mV, $I = -15$ mA; (d) $V = -120$ mV, $I = 80$ mA.
Ans. (a) -8 mW, (b) -7.5 mW, (c) 150 μW , (d) 9.6 mW

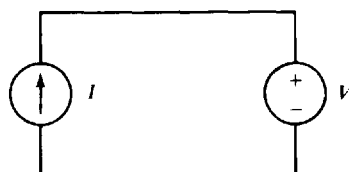

Fig. 1-11

1.57 For the circuit of Fig. 1-12, determine P_1 , P_2 , P_3 , which are powers absorbed, for (a) $I = 2$ A, (b) $I = 20$ mA, and (c) $I = -3$ A.

Ans. (a) $P_1 = 16$ W, $P_2 = -24$ W, $P_3 = -20$ W; (b) $P_1 = 0.16$ W, $P_2 = -2.4$ mW, $P_3 = -0.2$ W; (c) $P_1 = -24$ W, $P_2 = -54$ W, $P_3 = 30$ W

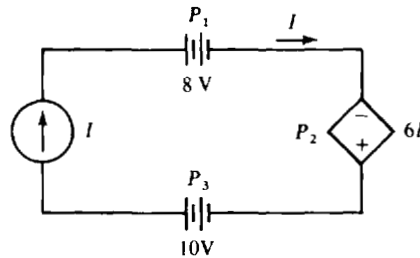

Fig. 1-12

1.58 Calculate the power absorbed by each component in the circuit of Fig. 1-13.

Ans. $P_1 = 16$ W, $P_2 = -48$ W, $P_3 = -48$ W, $P_4 = 80$ W

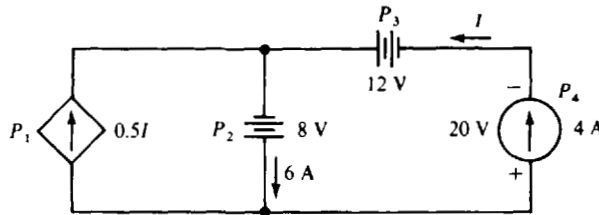

Fig. 1-13

1.59 Find the average input power to a radio that consumes 4500 J in 3 min.

Ans. 25 W

1.60 Find the voltage drop across a toaster that gives off 7500 J of heat when a 13.64-A current flows through it for 5 s.

Ans. 110 V

1.61 How many joules does a 40-W light bulb consume in 1 d?

Ans. 3.46 MJ

1.62 How long can a 12-V car battery supply 200 A to a starter motor if the battery has 28 MJ of chemical energy that can be converted to electric energy?

Ans. 3.24 h

1.63 How long does it take a 420-W color TV set to consume (a) 2 kWh and (b) 15 kJ?

Ans. (a) 4.76 h, (b) 35.7 s

- 1.64** Find the current drawn by a 110-V dc electric motor that delivers 2 hp. Assume 100 percent efficiency of operation.
Ans. 13.6 A
- 1.65** Find the efficiency of operation of an electric motor that delivers 5 hp while absorbing an input of 4190 W.
Ans. 89 percent
- 1.66** What is the operating efficiency of a dc electric motor that delivers 1 hp while drawing 7.45 A from a 115-V line?
Ans. 87 percent
- 1.67** Find the current drawn by a 100-V dc electric motor that operates at 85 percent efficiency while delivering 0.5 hp.
Ans. 4.39 A
- 1.68** What is the horsepower produced by an automobile starter motor that draws 250 A from a 12-V battery while operating at an efficiency of 90 percent?
Ans. 3.62 hp
- 1.69** What horsepower must an electric motor develop to operate a pump that pumps water at a rate of 24 000 liters per hour (L·h) up a vertical distance of 50 m if the efficiency of the pump is 90 percent? The gravitational force on 1 L of water is 9.78 N.
Ans. 4.86 hp
- 1.70** An ac electric motor drives a dc electric voltage generator. If the motor operates at an efficiency of 90 percent and the generator at an efficiency of 80 percent, and if the input power to the motor is 5 kW, find the output power from the generator.
Ans. 3.6 kW
- 1.71** Find the cost for one year (365 d) to operate a 20-W transistor FM-AM radio 5 h a day if electrical energy costs 8¢ kilowatthour.
Ans. \$2.92
- 1.72** For a cost of \$5, how long can a fully loaded 5-hp electric motor be run if the motor operates at an efficiency of 85 percent and if the electric rate is 6¢ kilowatthour?
Ans. 19 h
- 1.73** If electric energy costs 6¢ kilowatthour, calculate the utility bill for one month for operating eight 100-W light bulbs for 50 h each, ten 60-W light bulbs for 70 h each, one 2-kW air conditioner for 80 h, one 3-kW range for 45 h, one 420-W color TV set for 180 h, and one 300-W refrigerator for 75 h.
Ans. \$28.51.

Resistance

OHM'S LAW

In flowing through a conductor, free electrons collide with conductor atoms and lose some kinetic energy that is converted into heat. An applied voltage will cause them to regain energy and speed, but subsequent collisions will slow them down again. This speeding up and slowing down occurs continually as free electrons move among conductor atoms.

Resistance is this property of materials that opposes or resists the movement of electrons and makes it necessary to apply a voltage to cause current to flow. The SI unit of resistance is the *ohm* with symbol Ω , the Greek uppercase letter omega. The quantity symbol is R .

In metallic and some other types of conductors, the current is proportional to the applied voltage: Doubling the voltage doubles the current, tripling the voltage triples the current, and so on. If the applied voltage V and resulting current I have associated references, the relation between V and I is

$$I(\text{amperes}) = \frac{V(\text{volts})}{R(\text{ohms})}$$

in which R is the constant of proportionality. This relation is known as *Ohm's law*. For time-varying voltages and currents, $i = v R$. And for nonassociated references, $I = -V R$ or $i = -v R$.

From Ohm's law it is evident that, the greater the resistance, the less the current for any applied voltage. Also, the electric resistance of a conductor is 1Ω if an applied voltage of 1 V causes a current of 1 A to flow.

The inverse of resistance is often useful. It is called *conductance* and its quantity symbol is G . The SI unit of conductance is the *siemens* with symbol S , which is replacing the popular non-SI unit *mho* with symbol \mathfrak{U} (inverted omega). Since conductance is the inverse of resistance, $G = 1/R$. In terms of conductance, Ohm's law is

$$I(\text{amperes}) = G(\text{siemens}) \times V(\text{volts})$$

which shows that the greater the conductance of a conductor, the greater the current for any applied voltage.

RESISTIVITY

The resistance of a conductor of uniform cross section is directly proportional to the length of the conductor and inversely proportional to the cross-sectional area. Resistance is also a function of the temperature of the conductor, as is explained in the next section. At a fixed temperature the resistance of a conductor is

$$R = \rho \frac{l}{A}$$

where l is the conductor length in meters and A is the cross-sectional area in square meters. The constant of proportionality ρ , the Greek lowercase letter rho, is the quantity symbol for *resistivity*, the factor that depends on the type of material.

The SI unit of resistivity is the *ohm-meter* with unit symbol $\Omega\cdot\text{m}$. Table 2-1 shows the resistivities of some materials at 20 C .

A good conductor has a resistivity close to $10^{-8} \Omega\cdot\text{m}$. Silver, the best conductor, is too expensive for most uses. Copper is a common conductor, as is aluminum. Materials with resistivities greater than $10^{10} \Omega\cdot\text{m}$ are *insulators*. They can provide physical support without significant current leakage. Also,

Table 2-1

Material	Resistivity ($\Omega\cdot\text{m}$ at 20 C)	Material	Resistivity ($\Omega\cdot\text{m}$ at 20 C)
Silver	1.64×10^{-8}	Nichrome	100×10^{-8}
Copper, annealed	1.72×10^{-8}	Silicon	2500
Aluminum	2.83×10^{-8}	Paper	10^{10}
Iron	12.3×10^{-8}	Mica	5×10^{11}
Constantan	49×10^{-8}	Quartz	10^{17}

insulating coatings on wires prevent current leaks between wires that touch. Materials with resistivities in the range of 10^{-4} to $10^{-7} \Omega\cdot\text{m}$ are *semiconductors*, from which transistors are made.

The relationship among conductance, length, and cross-sectional area is

$$G = \sigma \frac{A}{l}$$

where the constant of proportionality σ , the Greek lowercase sigma, is the quantity symbol for *conductivity*. The SI unit of conductivity is the *siemens per meter* with symbol $\text{S}\cdot\text{m}^{-1}$.

TEMPERATURE EFFECTS

The resistances of most good conducting materials increase almost linearly with temperature over the range of normal operating temperatures, as shown by the solid line in Fig. 2-1. However, some materials, and common semiconductors in particular, have resistances that decrease with temperature increases.

If the straight-line portion in Fig. 2-1 is extended to the left, it crosses the temperature axis at a temperature T_0 at which the resistance appears to be zero. This temperature T_0 is the *inferred zero resistance temperature*. (The actual zero resistance temperature is -273 C .) If T_0 is known and if the resistance R_1 at another temperature T_1 is known, then the resistance R_2 at another temperature T_2 is, from straight-line geometry,

$$R_2 = \frac{T_2 - T_0}{T_1 - T_0} R_1$$

Table 2-2 has inferred zero resistance temperatures for some common conducting materials.

A different but equivalent way of finding the resistance R_2 is from

$$R_2 = R_1[1 + \alpha_1(T_2 - T_1)]$$

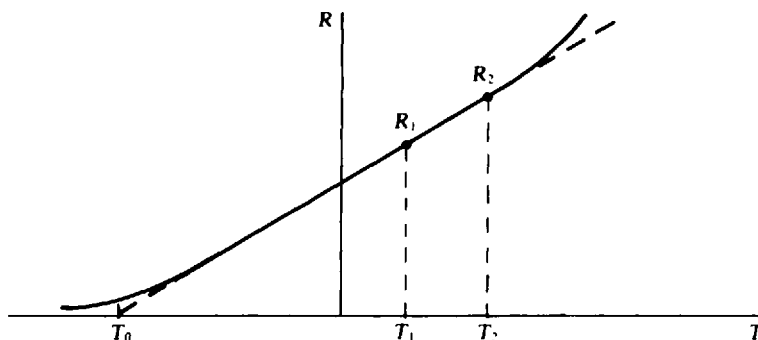

Fig. 2-1

Table 2-2

Material	Inferred zero resistance temperature (°C)
Tungsten	− 202
Copper	− 234.5
Aluminum	− 236
Silver	− 243
Constantan	− 125 000

Table 2-3

Material	Temperature coefficient (°C ^{−1} at 20°C)
Tungsten	0.0045
Copper	0.003 93
Aluminum	0.003 91
Silver	0.0038
Constantan	0.000 008
Carbon	− 0.0005

where α_1 , with the Greek lowercase alpha, is the *temperature coefficient of resistance* at the temperature T_1 . Often T_1 is 20 °C. Table 2-3 has temperature coefficients of resistance at 20°C for some common conducting materials. Note that the unit of α is *per degree Celsius* with symbol °C^{−1}.

RESISTORS

In a practical sense a *resistor* is a circuit component that is used because of its resistance. Mathematically, a resistor is a circuit component for which there is an algebraic relation between its instantaneous voltage and instantaneous current such as $v = iR$, the voltage-current relation for a resistor that obeys Ohm's law—a *linear resistor*. Any other type of voltage-current relation ($v = 4i^2 + 6$, for example) is for a *nonlinear resistor*. The term “resistor” usually designates a linear resistor. Nonlinear resistors are specified as such. Figure 2-2a shows the circuit symbol for a linear resistor, and Fig. 2-2b that for a nonlinear resistor.

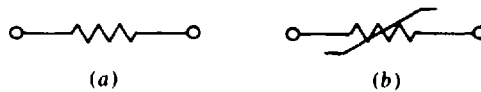

Fig. 2-2

RESISTOR POWER ABSORPTION

Substitution from $V = IR$ into $P = VI$ gives the power absorbed by a linear resistor in terms of resistance:

$$P = \frac{V^2}{R} = I^2 R$$

Every resistor has a *power rating*, also called *wattage rating*, that is the maximum power that the resistor can absorb without overheating to a destructive temperature.

NOMINAL VALUES AND TOLERANCES

Manufacturers print resistance values on resistor casings either in numerical form or in a color code. These values, though, are only *nominal values*: They are only approximately equal to the actual resistances. The possible percentage variation of resistance about the nominal value is called the *tolerance*. The popular carbon-composition resistors have tolerances of 20, 10, and 5 percent, which means that the actual resistances can vary from the nominal values by as much as ± 20 , ± 10 , and ± 5 percent of the nominal values.

COLOR CODE

The most popular resistance color code has nominal resistance values and tolerances indicated by the colors of either three or four bands around the resistor casing, as shown in Fig. 2-3.

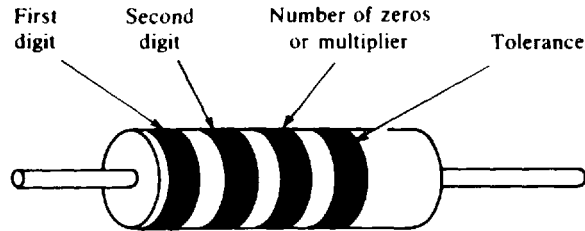

Fig. 2-3

Each color has a corresponding numerical value as specified in Table 2-4. The colors of the first and second bands correspond, respectively, to the first two digits of the nominal resistance value. Because the first digit is never zero, the first band is never black. The color of the third band, except for silver and gold, corresponds to the number of zeros that follow the first two digits. A third band of silver corresponds to a multiplier of 10^{-2} , and a third band of gold to a multiplier of 10^{-1} . The fourth band indicates the tolerance and is either gold- or silver-colored, or is missing. Gold corresponds to a tolerance of 5 percent, silver to 10 percent, and a missing band to 20 percent.

Table 2-4

Color	Number	Color	Number
Black	0	Blue	6
Brown	1	Violet	7
Red	2	Gray	8
Orange	3	White	9
Yellow	4	Gold	0.1
Green	5	Silver	0.01

OPEN AND SHORT CIRCUITS

An *open circuit* has an infinite resistance, which means that it has zero current flow through it for any finite voltage across it. On a circuit diagram it is indicated by two terminals not connected to anything—no path is shown for current to flow through. An open circuit is sometimes called an *open*.

A *short circuit* is the opposite of an open circuit. It has zero voltage across it for any finite current flow through it. On a circuit diagram a short circuit is designated by an ideal conducting wire—a wire with zero resistance. A short circuit is often called a *short*.

Not all open and short circuits are desirable. Frequently, one or the other is a circuit defect that occurs as a result of a component failure from an accident or the misuse of a circuit.

INTERNAL RESISTANCE

Every practical voltage or current source has an *internal resistance* that adversely affects the operation of the source. For any load except an open circuit, a voltage source has a loss of voltage across its internal resistance. And except for a short-circuit load, a current source has a loss of current through its internal resistance.

In a practical voltage source the internal resistance has almost the same effect as a resistor in series with an ideal voltage source, as shown in Fig. 2-4*a*. (Components in series carry the same current.) In a practical current source the internal resistance has almost the same effect as a resistor in parallel with an ideal current source, as shown in Fig. 2-4*b*. (Components in parallel have the same voltage across them.)

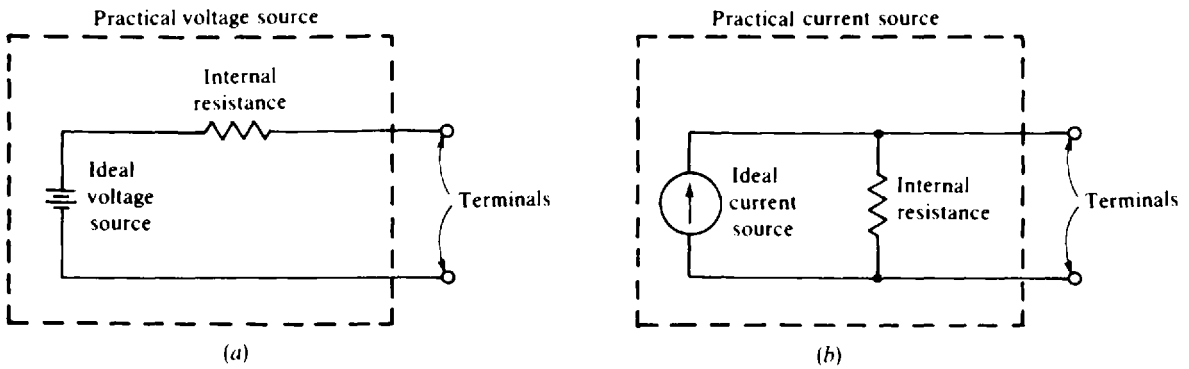

Fig. 2-4

Solved Problems

- 2.1 If an oven has a 240-V heating element with a resistance of $24\ \Omega$, what is the minimum rating of a fuse that can be used in the lines to the heating element?

The fuse must be able to carry the current of the heating element:

$$I = \frac{V}{R} = \frac{240}{24} = 10\ \text{A}$$

- 2.2 What is the resistance of a soldering iron that draws 0.8333 A at 120 V?

$$R = \frac{V}{I} = \frac{120}{0.8333} = 144\ \Omega$$

- 2.3 A toaster with $8.27\ \Omega$ of resistance draws 13.9 A. Find the applied voltage.

$$V = IR = 13.9 \times 8.27 = 115\ \text{V}$$

- 2.4 What is the conductance of a 560-k Ω resistor?

$$G = \frac{1}{R} = \frac{1}{560 \times 10^3} \text{ S} = 1.79\ \mu\text{S}$$

- 2.5 What is the conductance of an ammeter that indicates 20 A when 0.01 V is across it?

$$G = \frac{I}{V} = \frac{20}{0.01} = 2000\ \text{S}$$

- 2.6** Find the resistance at 20°C of an annealed copper bus bar 3 m in length and 0.5 cm by 3 cm in rectangular cross section.

The cross-sectional area of the bar is $(0.5 \times 10^{-2})(3 \times 10^{-2}) = 1.5 \times 10^{-4} \text{ m}^2$. Table 2-1 has the resistivity of annealed copper: $1.72 \times 10^{-8} \Omega \cdot \text{m}$ at 20°C. So,

$$R = \rho \frac{l}{A} = \frac{(1.72 \times 10^{-8})(3)}{1.5 \times 10^{-4}} \Omega = 344 \mu\Omega$$

- 2.7** Find the resistance of an aluminum wire that has a length of 1000 m and a diameter of 1.626 mm. The wire is at 20°C.

The cross-sectional area of the wire is πr^2 , in which $r = d/2 = 1.626 \times 10^{-3}/2 = 0.813 \times 10^{-3} \text{ m}$. From Table 2-1 the resistivity of aluminum is $2.83 \times 10^{-8} \Omega \cdot \text{m}$. So,

$$R = \rho \frac{l}{A} = \frac{(2.83 \times 10^{-8})(1000)}{\pi(0.813 \times 10^{-3})^2} = 13.6 \Omega$$

- 2.8** The resistance of a certain wire is 15 Ω. Another wire of the same material and at the same temperature has a diameter one-third as great and a length twice as great. Find the resistance of the second wire.

The resistance of a wire is proportional to the length and inversely proportional to the area. Also, the area is proportional to the square of the diameter. So, the resistance of the second wire is

$$R = \frac{15 \times 2}{(1/3)^2} = 270 \Omega$$

- 2.9** What is the resistivity of platinum if a cube of it 1 cm along each edge has a resistance of $10 \mu\Omega$ across opposite faces?

From $R = \rho l/A$ and the fact that $A = 10^{-2} \times 10^{-2} = 10^{-4} \text{ m}^2$ and $l = 10^{-2} \text{ m}$,

$$\rho = \frac{RA}{l} = \frac{(10 \times 10^{-6})(10^{-4})}{10^{-2}} = 10 \times 10^{-8} \Omega \cdot \text{m}$$

- 2.10** A 15-ft length of wire with a cross-sectional area of 127 cmils has a resistance of 8.74 Ω at 20°C. What material is the wire made from?

The material can be found from calculating the resistivity and comparing it with the resistivities given in Table 2-1. For this calculation it is convenient to use the fact that, by the definition of a circular mil, the corresponding area in square inches is the number of circular mils times $\pi/4 \times 10^{-6}$. From rearranging $R = \rho l/A$,

$$\rho = \frac{AR}{l} = \frac{[127(\pi/4 \times 10^{-6}) \text{ in}^2](8.74 \Omega)}{15 \cancel{\text{ft}}} \times \frac{1 \cancel{\text{ft}}}{12 \cancel{\text{in}}} \times \frac{0.0254 \text{ m}}{1 \cancel{\text{in}}} = 12.3 \times 10^{-8} \Omega \cdot \text{m}$$

Since iron has this resistivity in Table 2-1, the material must be iron.

- 2.11** What is the length of No. 28 AWG (0.000126 in² in cross-sectional area) Nichrome wire required for a 24-Ω resistor at 20°C?

From rearranging $R = \rho l/A$ and using the resistivity of Nichrome given in Table 2-1,

$$l = \frac{AR}{\rho} = \frac{(0.000126 \cancel{\text{in}^2})(24 \cancel{\Omega})}{100 \times 10^{-8} \cancel{\Omega \cdot \text{in}^2}} \times \frac{0.0254 \cancel{\text{in}}}{1 \cancel{\text{in}}} \times \frac{0.0254 \text{ m}}{1 \cancel{\text{in}}} = 1.95 \text{ m}$$

- 2.12** A certain aluminum wire has a resistance of 5Ω at 20°C . What is the resistance of an annealed copper wire of the same size and at the same temperature?

For the copper and aluminum wires, respectively,

$$R = \rho_c \frac{l}{A} \quad \text{and} \quad 5 = \rho_a \frac{l}{A}$$

Taking the ratio of the two equations causes the length and area quantities to divide out, with the result that the ratio of the resistances is equal to the ratio of the resistivities:

$$\frac{R}{5} = \frac{\rho_c}{\rho_a} \quad \text{or} \quad R = \frac{\rho_c}{\rho_a} \times 5$$

Then with the insertion of resistivities from Table 2-1,

$$R = \frac{1.72 \times 10^{-8}}{2.83 \times 10^{-8}} \times 5 = 3.04 \Omega$$

- 2.13** A wire 50 m in length and 2 mm^2 in cross section has a resistance of 0.56Ω . A 100-m length of wire of the same material has a resistance of 2Ω at the same temperature. Find the diameter of this wire.

From the data given for the first wire, the resistivity of the conducting material is

$$\rho = \frac{RA}{l} = \frac{0.56(2 \times 10^{-6})}{50} = 2.24 \times 10^{-8} \Omega\text{-m}$$

Therefore the cross-sectional area of the second wire is

$$A = \frac{\rho l}{R} = \frac{(2.24 \times 10^{-8})(100)}{2} = 1.12 \times 10^{-6} \text{ m}^2$$

and, from $A = \pi(d/2)^2$, the diameter is

$$d = 2 \sqrt{\frac{A}{\pi}} = 2 \sqrt{\frac{1.12 \times 10^{-6}}{\pi}} = 1.19 \times 10^{-3} \text{ m} = 1.19 \text{ mm}$$

- 2.14** A wire-wound resistor is to be made from 0.2-mm-diameter constantan wire wound around a cylinder that is 1 cm in diameter. How many turns of wire are required for a resistance of 50Ω at 20°C ?

The number of turns equals the wire length divided by the circumference of the cylinder. From $R = \rho l/A$ and the resistivity of constantan given in Table 2-1, the length of the wire that has a resistance of 50Ω is

$$l = \frac{RA}{\rho} = \frac{R\pi r^2}{\rho} = \frac{50\pi(0.1 \times 10^{-3})^2}{49 \times 10^{-8}} = 3.21 \text{ m}$$

The circumference of the cylinder is $2\pi r$, in which $r = 10^{-2}/2 = 0.005 \text{ m}$, the radius of the cylinder. So, the number of turns is

$$\frac{l}{2\pi r} = \frac{3.21}{2\pi(0.005)} = 102 \text{ turns}$$

- 2.15** A No. 14 AWG standard annealed copper wire is 0.00323 in^2 in cross section and has a resistance of $2.58 \text{ m}\Omega/\text{ft}$ at 25°C . What is the resistance of 500 ft of No. 6 AWG wire of the same material at 25°C ? The cross-sectional area of this wire is 0.0206 in^2 .

Perhaps the best approach is to calculate the resistance of a 500-ft length of the No. 14 AWG wire,

$$(2.58 \times 10^{-3})(500) = 1.29 \Omega$$

and then take the ratio of the two $R = \rho l / A$ equations. Since the resistivities and lengths are the same, they divide out, with the result that

$$\frac{R}{1.29} = \frac{0.00323}{0.0206} \quad \text{or} \quad R = \frac{0.00323}{0.0206} \times 1.29 = 0.202 \Omega$$

- 2.16** The conductance of a certain wire is 0.5 S. Another wire of the same material and at the same temperature has a diameter twice as great and a length three times as great. What is the conductance of the second wire?

The conductance of a wire is proportional to the area and inversely proportional to the length. Also, the area is proportional to the square of the diameter. Therefore the conductance of the second wire is

$$G = \frac{0.5 \times 2^2}{3} = 0.667 \text{ S}$$

- 2.17** Find the conductance of 100 ft of No. 14 AWG iron wire, which has a diameter of 64 mils. The temperature is 20 C.

The conductance formula is $G = \sigma A / l$, in which $\sigma = 1/\rho$ and $A = \pi(d/2)^2$. Of course, the resistivity of iron can be obtained from Table 2-1. Thus,

$$G = \sigma \frac{A}{l} = \frac{1}{12.3 \times 10^{-8} \text{ } \Omega \cdot \text{m}} \times \frac{\text{S}}{\text{m}} \times \frac{\pi(64 \times 10^{-3} \text{ m})^2}{100 \text{ m}} \times \frac{1 \text{ m}}{12 \text{ m}} \times \frac{0.0254 \text{ m}}{1 \text{ m}} = 0.554 \text{ S}$$

- 2.18** The resistance of a certain copper power line is 100 Ω at 20 C. What is its resistance when the sun heats up the line to 38 C?

From Table 2-2 the inferred absolute zero resistance temperature of copper is -234.5 C, which is T_0 in the formula $R_2 = R_1(T_2 - T_0)/(T_1 - T_0)$. Also, from the given data, $T_2 = 38$ C, $R_1 = 100 \Omega$, and $T_1 = 20$ C. So, the wire resistance at 38 C is

$$R_2 = \frac{T_2 - T_0}{T_1 - T_0} R_1 = \frac{38 - (-234.5)}{20 - (-234.5)} \times 100 = 107 \Omega$$

- 2.19** When 120 V is applied across a certain light bulb, a 0.5-A current flows, causing the temperature of the tungsten filament to increase to 2600 C. What is the resistance of the light bulb at the normal room temperature of 20 C?

The resistance of the energized light bulb is $120/0.5 = 240 \Omega$. And since from Table 2-2 the inferred zero resistance temperature for tungsten is -202 C, the resistance at 20 C is

$$R_2 = \frac{T_2 - T_0}{T_1 - T_0} R_1 = \frac{20 - (-202)}{2600 - (-202)} \times 240 = 19 \Omega$$

- 2.20** A certain unenergized copper transformer winding has a resistance of 30 Ω at 20 C. Under rated operation, however, the resistance increases to 35 Ω . Find the temperature of the energized winding.

The formula $R_2 = R_1(T_2 - T_0)/(T_1 - T_0)$ solved for T_2 becomes

$$T_2 = \frac{R_2(T_1 - T_0)}{R_1} + T_0$$

From the specified data, $R_2 = 35 \Omega$, $T_1 = 20 \text{ C}$, and $R_1 = 30 \Omega$. Also, from Table 2-2, $T_0 = -234.5 \text{ C}$. So,

$$T_2 = \frac{35[20 - (-234.5)]}{30} - 234.5 = 62.4 \text{ C}$$

- 2.21** The resistance of a certain aluminum power line is 150Ω at 20 C . Find the line resistance when the sun heats up the line to 42 C . First use the inferred zero resistance temperature formula and then the temperature coefficient of resistance formula to show that the two formulas are equivalent.

From Table 2-2 the zero resistance temperature of aluminum is -236 C . Thus,

$$R_2 = \frac{T_2 - T_0}{T_1 - T_0} R_1 = \frac{42 - (-236)}{20 - (-236)} \times 150 = 163 \Omega$$

From Table 2-3 the temperature coefficient of resistance of aluminum is 0.00391 C^{-1} at 20 C . So,

$$R_2 = R_1[1 + \alpha_1(T_2 - T_1)] = 150[1 + 0.00391(42 - 20)] = 163 \Omega$$

- 2.22** Find the resistance at 35 C of an aluminum wire that has a length of 200 m and a diameter of 1 mm .

The wire resistance at 20 C can be found and used in the temperature coefficient of resistance formula. (Alternatively, the inferred zero resistance temperature formula can be used.) Since the cross-sectional area of the wire is $\pi(d/2)^2$, where $d = 10^{-3} \text{ m}$, and since from Table 2-1 the resistivity of aluminum is $2.83 \times 10^{-8} \Omega\text{-m}$, the wire resistance at 20 C is

$$R = \rho \frac{l}{A} = (2.83 \times 10^{-8}) \times \frac{200}{\pi(10^{-3}/2)^2} = 7.21 \Omega$$

The only other quantity needed to calculate the wire resistance at 35 C is the temperature coefficient of resistance of aluminum at 20 C . From Table 2-3 it is 0.00391 C^{-1} . So,

$$R_2 = R_1[1 + \alpha(T_2 - T_1)] = 7.21[1 + 0.00391(35 - 20)] = 7.63 \Omega$$

- 2.23** Derive a formula for calculating the temperature coefficient of resistance from the temperature T_1 of a material and T_0 , its inferred zero resistance temperature.

In $R_2 = R_1[1 + \alpha_1(T_2 - T_1)]$ select $T_2 = T_0$. Then $R_2 = 0 \Omega$, by definition. The result is $0 = R_1[1 + \alpha_1(T_0 - T_1)]$, from which

$$\alpha_1 = \frac{1}{T_1 - T_0}$$

- 2.24** Calculate the temperature coefficient of resistance of aluminum at 30 C and use it to find the resistance of an aluminum wire at 70 C if the wire has a resistance of 40Ω at 30 C .

From Table 2-2, aluminum has an inferred zero resistance temperature of -236 C . With this value inserted, the formula derived in the solution to Prob. 2.23 gives

$$\alpha_{30 \text{ C}} = \frac{1}{T_1 - T_0} = \frac{1}{30 - (-236)} = 0.003759 \text{ C}^{-1}$$

So $R_2 = R_1[1 + \alpha_1(T_2 - T_1)] = 40[1 + 0.003759(70 - 30)] = 46 \Omega$

- 2.25** Find the resistance of an electric heater that absorbs 2400 W when connected to a 120-V line.

From $P = V^2/R$,

$$R = \frac{V^2}{P} = \frac{120^2}{2400} = 6 \Omega$$

- 2.26** Find the internal resistance of a 2-kW water heater that draws 8.33 A.

From $P = I^2R$,

$$R = \frac{P}{I^2} = \frac{2000}{8.33^2} = 28.8 \Omega$$

- 2.27** What is the greatest voltage that can be applied across a $\frac{1}{8}$ -W, 2.7-M Ω resistor without causing it to overheat?

From $P = V^2/R$,

$$V = \sqrt{RP} = \sqrt{(2.7 \times 10^6)(\frac{1}{8})} = 581 \text{ V}$$

- 2.28** If a nonlinear resistor has a voltage-current relation of $V = 3I^2 + 4$, what current does it draw when energized by 61 V? Also, what power does it absorb?

Inserting the applied voltage into the nonlinear equation results in $61 = 3I^2 + 4$, from which

$$I = \sqrt{\frac{61 - 4}{3}} = 4.36 \text{ A}$$

Then from $P = VI$,

$$P = 61 \times 4.36 = 266 \text{ W}$$

- 2.29** At 20°C a pn junction silicon diode has a current-voltage relation of $I = 10^{-14}(e^{40V} - 1)$. What is the diode voltage when the current is 50 mA?

From the given formula,

$$50 \times 10^{-3} = 10^{-14}(e^{40V} - 1)$$

Multiplying both sides by 10^{14} and adding 1 to both sides results in

$$50 \times 10^{11} + 1 = e^{40V}$$

Then from the natural logarithm of both sides,

$$V = \frac{1}{40} \ln(50 \times 10^{11} + 1) = 0.73 \text{ V}$$

- 2.30** What is the resistance range for (a) a 10 percent, 470- Ω resistor, and (b) a 20 percent, 2.7-M Ω resistor? (*Hint*: 10 percent corresponds to 0.1 and 20 percent to 0.2.)

- (a) The resistance can be as much as $0.1 \times 470 = 47 \Omega$ from the 470- Ω nominal value. So, the resistance can be as small as $470 - 47 = 423 \Omega$ or as great as $470 + 47 = 517 \Omega$.
- (b) Since the maximum resistance variation from the nominal value is $0.2(2.7 \times 10^6) = 0.54 \text{ M}\Omega$, the resistance can be as small as $2.7 - 0.54 = 2.16 \text{ M}\Omega$ or as great as $2.7 + 0.54 = 3.24 \text{ M}\Omega$.

- 2.31** A voltage of 110 V is across a 5 percent, 20-k Ω resistor. What range must the current be in? (*Hint*: 5 percent corresponds to 0.05.)

The resistance can be as much as $0.05(20 \times 10^3) = 10^3 \Omega$ from the nominal value, which means that the resistance can be as small as $20 - 1 = 19 \text{ k}\Omega$ or as great as $20 + 1 = 21 \text{ k}\Omega$. Therefore, the current can be as small as

$$\frac{110}{21 \times 10^3} = 5.24 \text{ mA}$$

or as great as

$$\frac{110}{19 \times 10^3} = 5.79 \text{ mA}$$

2.32 What are the colors of the bands on a 10 percent, 5.6- Ω resistor?

Since $5.6 = 56 \times 0.1$, the resistance has a first digit of 5, a second digit of 6, and a multiplier of 0.1. From Table 2-4, green corresponds to 5, blue to 6, and gold to 0.1. Also, silver corresponds to the 10 percent tolerance. So, the color bands and arrangement are green-blue-gold-silver from an end to the middle of the resistor casing.

2.33 Determine the colors of the bands on a 20 percent, 2.7-M Ω resistor.

The numerical value of the resistance is 2 700 000, which is a 2 and a 7 followed by five zeros. From Table 2-4 the corresponding color code is red for the 2, violet for the 7, and green for the five zeros. Also, there is a missing color band for the 20 percent tolerance. So, the color bands from an end of the resistor casing to the middle are red-violet-green-missing.

2.34 What are the nominal resistance and tolerance of a resistor with color bands in the order of green-blue-yellow-silver from an end of the resistor casing toward the middle?

From Table 2-4, green corresponds to 5, blue to 6, and yellow to 4. The 5 is the first digit and 6 the second digit of the resistance value, and 4 is the number of trailing zeros. Consequently, the resistance is 560 000 Ω or 560 k Ω . The silver band designates a 10 percent tolerance.

2.35 Find the resistance corresponding to color bands in the order of red-yellow-black-gold.

From Table 2-4, red corresponds to 2, yellow to 4, and black to 0 (no trailing zeros). The fourth band of gold corresponds to a 5 percent tolerance. So, the resistance is 24 Ω with a 5 percent tolerance.

2.36 If a 12-V car battery has a 0.04- Ω internal resistance, what is the battery terminal voltage when the battery delivers 40 A?

The battery terminal voltage is the generated voltage minus the voltage drop across the internal resistance:

$$V = 12 - IR = 12 - 40(0.04) = 10.4 \text{ V}$$

2.37 If a 12-V car battery has a 0.1- Ω internal resistance, what terminal voltage causes a 4-A current to flow *into* the positive terminal?

The applied voltage must equal the battery generated voltage plus the voltage drop across the internal resistance:

$$V = 12 + IR = 12 + 4(0.1) = 12.4 \text{ V}$$

2.38 If a 10-A current source has a 100- Ω internal resistance, what is the current flow from the source when the terminal voltage is 200 V?

The current flow from the source is the 10 A minus the current flow through the internal resistance:

$$I = 10 - \frac{V}{R} = 10 - \frac{200}{100} = 8 \text{ A}$$

Supplementary Problems

2.39 What is the resistance of a 240-V electric clothes dryer that draws 23.3 A?

Ans. 10.3 Ω

- 2.40** If a voltmeter has $500\text{ k}\Omega$ of internal resistance, find the current flow through it when it indicates 86 V .
Ans. $172\ \mu\text{A}$
- 2.41** If an ammeter has $2\text{ m}\Omega$ of internal resistance, find the voltage across it when it indicates 10 A .
Ans. 20 mV
- 2.42** What is the conductance of a $39\text{-}\Omega$ resistor?
Ans. 25.6 mS
- 2.43** What is the conductance of a voltmeter that indicates 150 V when 0.3 mA flows through it?
Ans. $2\ \mu\text{S}$
- 2.44** Find the resistance at 20 C of an annealed copper bus bar 2 m long and 1 cm by 4 cm in rectangular cross section.
Ans. $86\ \mu\Omega$
- 2.45** What is the resistance of an annealed copper wire that has a length of 500 m and a diameter of 0.404 mm ?
Ans. $67.1\ \Omega$
- 2.46** The resistance of a wire is $25\ \Omega$. Another wire of the same material and at the same temperature has a diameter twice as great and a length six times as great. Find the resistance of the second wire.
Ans. $37.5\ \Omega$
- 2.47** What is the resistivity of tin if a cube of it 10 cm along each edge has a resistance of $1.15\ \mu\Omega$ across opposite faces?
Ans. $11.5 \times 10^{-8}\ \Omega\text{-m}$
- 2.48** A 40-m length of wire with a diameter of 0.574 mm has a resistance of $75.7\ \Omega$ at 20 C . What material is the wire made from?
Ans. Constantan
- 2.49** What is the length of No. 30 AWG (10.0-mil diameter) constantan wire at 20 C required for a $200\text{-}\Omega$ resistor?
Ans. 20.7 m
- 2.50** If No. 29 AWG annealed copper wire at 20 C has a resistance of $83.4\ \Omega$ per 1000 ft , what is the resistance per 100 ft of Nichrome wire of the same size and at the same temperature?
Ans. $485\ \Omega$ per 100 ft
- 2.51** A wire with a resistance of $5.16\ \Omega$ has a diameter of 45 mils and a length of 1000 ft . Another wire of the same material has a resistance of $16.5\ \Omega$ and a diameter of 17.9 mils . What is the length of this second wire if both wires are at the same temperature?
Ans. 506 ft
- 2.52** A wirewound resistor is to be made from No. 30 AWG (10.0-mil diameter) constantan wire wound around a cylinder that is 0.5 cm in diameter. How many turns are required for a resistance of $25\ \Omega$ at 20 C ?
Ans. 165 turns
- 2.53** The conductance of a wire is 2.5 S . Another wire of the same material and at the same temperature has a diameter one-fourth as great and a length twice as great. Find the conductance of the second wire.
Ans. 78.1 mS

- 2.54** Find the conductance of 5 m of Nichrome wire that has a diameter of 1 mm.
Ans. 157 mS
- 2.55** If an aluminum power line has a resistance of $80\ \Omega$ at 30°C , what is its resistance when cold air lowers its temperature to -10°C ?
Ans. $68\ \Omega$
- 2.56** If the resistance of a constantan wire is $2\ \text{M}\Omega$ at -150°C , what is its resistance at 200°C ?
Ans. $2.006\ \text{M}\Omega$
- 2.57** The resistance of an aluminum wire is $2.4\ \Omega$ at -5°C . At what temperature will it be $2.8\ \Omega$?
Ans. 33.5°C
- 2.58** What is the resistance at 90°C of a carbon rod that has a resistance of $25\ \Omega$ at 20°C ?
Ans. $24.1\ \Omega$
- 2.59** Find the temperature coefficient of resistance of iron at 20°C if iron has an inferred zero resistance temperature of -162°C .
Ans. $0.0055^\circ\text{C}^{-1}$
- 2.60** What is the maximum current that a 1-W, $56\text{-k}\Omega$ resistor can safely conduct?
Ans. 4.23 mA
- 2.61** What is the maximum voltage that can be safely applied across a $\frac{1}{2}$ -W, $91\text{-}\Omega$ resistor?
Ans. 6.75 V
- 2.62** What is the resistance of a 240-V, 5600-W electric heater?
Ans. $10.3\ \Omega$
- 2.63** A nonlinear resistor has a voltage-current relation of $V = 2I^2 + 3I + 10$. Find the current drawn by this resistor when 37 V is applied across it.
Ans. 3 A
- 2.64** If a diode has a current-voltage relation of $I = 10^{-14}(e^{40V} - 1)$, what is the diode voltage when the current is 150 mA?
Ans. 0.758 V
- 2.65** What is the resistance range for a 5 percent, $75\text{-k}\Omega$ resistor?
Ans. 71.25 to $78.75\ \text{k}\Omega$
- 2.66** A 12.1-mA current flows through a 10 percent, $2.7\text{-k}\Omega$ resistor. What range must the resistor voltage be in?
Ans. 29.4 to 35.9 V
- 2.67** What are the resistor color codes for tolerances and nominal resistances of (a) 10 percent, $0.18\ \Omega$; (b) 5 percent, $39\ \text{k}\Omega$; and (c) 20 percent, $20\ \text{M}\Omega$?
Ans. (a) Brown-gray-silver-silver, (b) orange-white-orange-gold, (c) red-black-blue-missing
- 2.68** Find the tolerances and nominal resistances corresponding to color codes of (a) brown-brown-silver-gold, (b) green-brown-brown-missing, and (c) blue-gray-green-silver.
Ans. (a) 5 percent, $0.11\ \Omega$; (b) 20 percent, $510\ \Omega$; (c) 10 percent, $6.8\ \text{M}\Omega$

2.69 A battery provides 6 V on open circuit and it provides 5.4 V when delivering 6 A. What is the internal resistance of the battery?

Ans. 0.1 Ω

2.70 A 3-hp automobile electric starter motor operates at 85 percent efficiency from a 12-V battery. What is the battery internal resistance if the battery terminal voltage drops to 10 V when energizing the starter motor?

Ans. 7.60 m Ω

2.71 A short circuit across a current source draws 20 A. When the current source has an open circuit across it, the terminal voltage is 600 V. Find the internal resistance of the source.

Ans. 30 Ω

2.72 A short circuit across a current source draws 15 A. If a 10- Ω resistor across the source draws 13 A, what is the internal resistance of the source?

Ans. 65 Ω

Series and Parallel DC Circuits

BRANCHES, NODES, LOOPS, MESHES, SERIES- AND PARALLEL-CONNECTED COMPONENTS

Strictly speaking, a *branch* of a circuit is a single component such as a resistor or a source. Occasionally, though, this term is applied to a group of components that carry the same current, especially when they are of the same type.

A *node* is a connection point between two or more branches. On a circuit diagram a node is sometimes indicated by a dot that may be a solder point in the actual circuit. The node also includes all wires connected to the point. In other words, it includes all points at the same potential. If a short circuit connects two nodes, these two nodes are equivalent to and in fact are just a single node, even if two dots are shown.

A *loop* is any simple closed path in a circuit. A *mesh* is a loop that does not have a closed path in its interior. No components are inside a mesh.

Components are connected in *series* if they carry the same current.

Components are connected in *parallel* if the same voltage is across them.

KIRCHHOFF'S VOLTAGE LAW AND SERIES DC CIRCUITS

Kirchhoff's voltage law, abbreviated KVL, has three equivalent versions: At any instant around a loop, in either a clockwise or counterclockwise direction,

1. The algebraic sum of the voltage drops is zero.
2. The algebraic sum of the voltage rises is zero.
3. The algebraic sum of the voltage drops equals the algebraic sum of the voltage rises.

In all these versions, the word "algebraic" means that the signs of the voltage drops and rises are included in the additions. Remember that a voltage rise is a negative voltage drop, and that a voltage drop is a negative voltage rise. For loops with no current sources, the most convenient KVL version is often the third one, restricted such that the voltage drops are only across resistors and the voltage rises are only across voltage sources.

In the application of KVL, a loop current is usually referenced clockwise, as shown in the series circuit of Fig. 3-1, and KVL is applied in the direction of the current. (This is a series circuit because the same current I flows through all components.) The sum of the voltage drops across the resistors, $V_1 + V_2 + V_3$, is set equal to the voltage rise V_S across the voltage source: $V_1 + V_2 + V_3 = V_S$. Then the IR Ohm's law relations are substituted for the resistor voltages:

$$V_S = V_1 + V_2 + V_3 = IR_1 + IR_2 + IR_3 = I(R_1 + R_2 + R_3) = IR_T$$

from which $I = V_S/R_T$ and $R_T = R_1 + R_2 + R_3$. This R_T is the *total resistance* of the series-connected resistors. Another term used is *equivalent resistance*, with symbol R_{eq} .

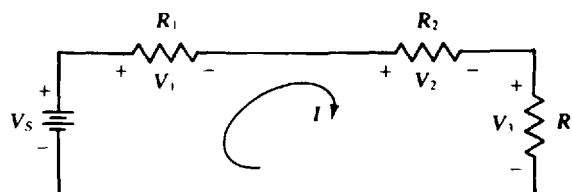

Fig. 3-1

From this result it should be evident that, in general, the total resistance of series-connected resistors (series resistors) equals the sum of the individual resistances:

$$R_T = R_1 + R_2 + R_3 + \cdots$$

Further, if the resistances are the same (R), and if there are N of them, then $R_T = NR$. Finding the current in a series circuit is easier using total resistance than applying KVL directly.

If a series circuit has more than one voltage source, then

$$I(R_1 + R_2 + R_3 + \cdots) = V_{S_1} + V_{S_2} + V_{S_3} + \cdots$$

in which each V_S term is positive for a voltage rise and is negative for a voltage drop in the direction of I .

KVL is seldom applied to a loop containing a current source because the voltage across the current source is not known and there is no formula for it.

VOLTAGE DIVISION

The *voltage division* or *voltage divider rule* applies to resistors in series. It gives the voltage across any resistor in terms of the resistances and the total voltage across the series combination—the step of finding the resistor current is eliminated. The voltage division formula is easy to find from the circuit shown in Fig. 3-1. Consider finding the voltage V_2 . By Ohm's law, $V_2 = IR_2$. Also, $I = V_S/(R_1 + R_2 + R_3)$. Eliminating I results in

$$V_2 = \frac{R_2}{R_1 + R_2 + R_3} V_S$$

In general, for any number of series resistors with a total resistance of R_T and with a voltage of V_S across the series combination, the voltage V_X across one of the resistors R_X is

$$V_X = \frac{R_X}{R_T} V_S$$

This is the formula for the voltage division or divider rule. For this formula, V_S and V_X must have opposing polarities; that is, around a closed path one must be a voltage drop and the other a voltage rise. If both are rises or both are drops, the formula requires a negative sign. The voltage V_S need not be that of a source. It is just the total voltage across the series resistors.

KIRCHHOFF'S CURRENT LAW AND PARALLEL DC CIRCUITS

Kirchhoff's current law, abbreviated KCL, has three equivalent versions:

At any instant in a circuit,

1. The algebraic sum of the currents leaving a closed surface is zero.
2. The algebraic sum of the currents entering a closed surface is zero.
3. The algebraic sum of the currents entering a closed surface equals the algebraic sum of those leaving.

The word "algebraic" means that the signs of the currents are included in the additions. Remember that a current entering is a negative current leaving, and that a current leaving is a negative current entering.

In almost all circuit applications, the closed surfaces of interest are those enclosing nodes. So, there is little loss of generality in using the word "node" in place of "closed surface" in each KCL version. Also, for a node to which no voltage sources are connected the most convenient KCL version is often the third one, restricted such that the currents entering are from current sources and the currents leaving are through resistors.

In the application of KCL, one node is selected as the *ground* or *reference* or *datum node*, which is often indicated by the ground symbol (\perp). Usually, the node at the bottom of the circuit is the ground node, as shown in the parallel circuit of Fig. 3-2. (This is a parallel circuit because the same voltage V is across all circuit components.) The voltages on other nodes are almost always referenced positive with respect to the ground node. At the nongrounded node in the circuit shown in Fig. 3-2, the sum of the currents leaving through resistors, $I_1 + I_2 + I_3$, equals the current I_s entering this node from the current source: $I_1 + I_2 + I_3 = I_s$. The substitution of the $I = GV$ Ohm's law relations for the resistor currents results in

$$I_s = I_1 + I_2 + I_3 = G_1V + G_2V + G_3V = (G_1 + G_2 + G_3)V = G_T V$$

from which $V = I_s/G_T$ and $G_T = G_1 + G_2 + G_3 = 1/R_1 + 1/R_2 + 1/R_3$. This G_T is the *total conductance* of the circuit. Another term used is *equivalent conductance*, with symbol G_{eq} .

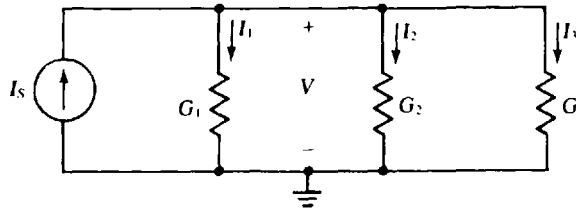

Fig. 3-2

From this result it should be evident that, in general, the total conductance of parallel-connected resistors (parallel resistors) equals the sum of the individual conductances:

$$G_T = G_1 + G_2 + G_3 + \dots$$

If the conductances are the same (G), and if there are N of them, then $G_T = NG$ and $R_T = 1/G_T = 1/NG = R/N$. Finding the voltage in a parallel circuit is easier using total conductance than applying KCL directly.

Sometimes working with resistances is preferable to conductances. Then from $R_T = 1/G_T = 1/(G_1 + G_2 + G_3 + \dots)$,

$$R_T = \frac{1}{1/R_1 + 1/R_2 + 1/R_3 + \dots}$$

An important check on calculations with this formula is that R_T must always be less than the least resistance of the parallel resistors.

For the special case of just two parallel resistors,

$$R_T = \frac{1}{1/R_1 + 1/R_2} = \frac{R_1 R_2}{R_1 + R_2}$$

So, the total or equivalent resistance of two parallel resistors is the product of the resistances divided by the sum.

The symbol \parallel as in $R_1 \parallel R_2$ indicates the resistance of two parallel resistors: $R_1 \parallel R_2 = R_1 R_2 / (R_1 + R_2)$. It is also sometimes used to indicate that two resistors are in parallel.

If a parallel circuit has more than one current source,

$$(G_1 + G_2 + G_3 + \dots)V = I_{s_1} + I_{s_2} + I_{s_3} + \dots$$

in which each I_s term is positive for a source current entering the nongrounded node and is negative for a source current leaving this node.

KCL is seldom applied to a node to which a voltage source is connected. The reason is that the current through a voltage source is not known and there is no formula for it.

CURRENT DIVISION

The *current division* or *current divider rule* applies to resistors in parallel. It gives the current through any resistor in terms of the conductances and the current into the parallel combination—the step of finding the resistor voltage is eliminated. The current division formula is easy to derive from the circuit shown in Fig. 3-2. Consider finding the current I_2 . By Ohm's law, $I_2 = G_2V$. Also, $V = I_S/(G_1 + G_2 + G_3)$. Eliminating V results in

$$I_2 = \frac{G_2}{G_1 + G_2 + G_3} I_S$$

In general, for any number of parallel resistors with a total conductance G_T and with a current I_S entering the parallel combination, the current I_X through one of the resistors with conductance G_X is

$$I_X = \frac{G_X}{G_T} I_S$$

This is the formula for the current division or divider rule. For this formula, I_S and I_X must be referenced in the same direction, with I_X referenced away from the node of the parallel resistors that I_S is referenced into. If both currents enter this node, then the formula requires a negative sign. The current I_S need not be that of a source. It is just the total current entering the parallel resistors.

For the special case of two parallel resistors, the current division formula is usually expressed in resistances instead of conductances. If the two resistances are R_1 and R_2 , the current I_1 in the resistor with resistance R_1 is

$$I_1 = \frac{G_1}{G_1 + G_2} I_S = \frac{1/R_1}{1/R_1 + 1/R_2} I_S = \frac{R_2}{R_1 + R_2} I_S$$

In general, as this formula indicates, the current flowing in one of two parallel resistors equals the resistance of the other resistor divided by the sum of the resistances, all times the current flowing into the parallel combination.

KILOHM-MILLIAMPERE METHOD

The basic equations $V = RI$, $I = GV$, $P = VI$, $P = V^2/R$, and $P = I^2R$ are valid, of course, for the units of volts (V), amperes (A), ohms (Ω), siemens (S), and watts (W). But they are equally valid for the units of volts (V), milliamperes (mA), kilohms (k Ω), millisiemens (mS), and milliwatts (mW), the use of which is sometimes referred to as the *kilohm-milliamperere method*. In this book, this second set will be used almost exclusively in the writing of network equations when the network resistances are in the kilohm range, because with it the writing of powers of 10 can be avoided.

Solved Problems

3.1 Determine the number of nodes and branches in the circuit shown in Fig. 3-3.

Dots 1 and 2 are one node, as are dots 3 and 4 and also dots 5 and 6, all with connecting wires. Dot 7 and the two wires on both sides are another node, as are dot 8 and the two wires on both sides of it. So, there are five nodes. Each of the shown components A through H is a branch—eight branches in all.

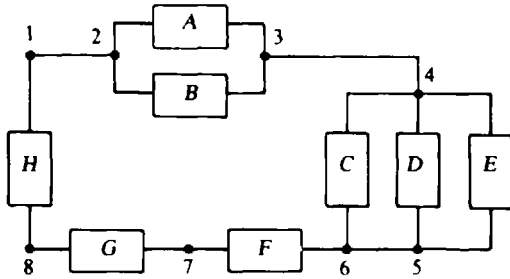

Fig. 3-3

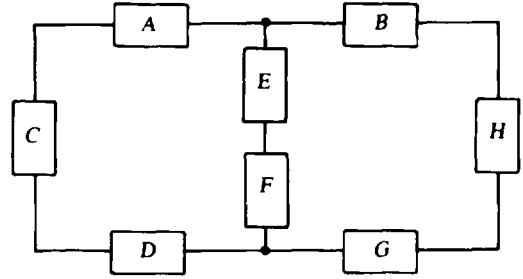

Fig. 3-4

3.2 Which components in Fig. 3-3 are in series and which are in parallel?

Components *F*, *G*, and *H* are in series because they carry the same current. Components *A* and *B*, being connected together at both ends, have the same voltage and so are in parallel. The same is true for components *C*, *D*, and *E*— they are in parallel. Further, the parallel group of *A* and *B* is in series with the parallel group of *C*, *D*, and *E*, and both groups are in series with components *F*, *G*, and *H*.

3.3 Identify all the loops and all the meshes for the circuit shown in Fig. 3-4. Also, specify which components are in series and which are in parallel.

There are three loops: one of components *A*, *E*, *F*, *D*, and *C*; a second of components *B*, *H*, *G*, *F*, and *E*; and a third of *A*, *B*, *H*, *G*, *D*, and *C*. The first two loops are also meshes, but the third is not because components *E* and *F* are inside it. Components *A*, *C*, and *D* are in series because they carry the same current. For the same reason, components *E* and *F* are in series, as also are components *B*, *H*, and *G*. No components are in parallel.

3.4 Repeat Prob. 3.3 for the circuit shown in Fig. 3-5.

The three loops of components *A*, *B*, and *C*; *C*, *D*, and *E*; and *F*, *D*, and *B* are also meshes—the only meshes. All other loops are not meshes because components are inside them. Components *A*, *B*, *D*, and *E* form one of these other loops; components *A*, *F*, and *E* another one; components *A*, *F*, *D*, and *C* a third; and components *F*, *E*, *C*, and *B* a fourth. The circuit has three meshes and seven loops. No components are in series or in parallel.

3.5 What is *V* across the open circuit in the circuit shown in Fig. 3-6?

The sum of the voltage drops in a clockwise direction is, starting from the upper left corner,

$$60 - 40 + V - 10 + 20 = 0 \quad \text{from which} \quad V = -30 \text{ V}$$

In the summation, the 40 and 10 V are negative because they are voltage rises in a clockwise direction. The negative sign in the answer indicates that the actual open-circuit voltage has a polarity opposite the shown reference polarity.

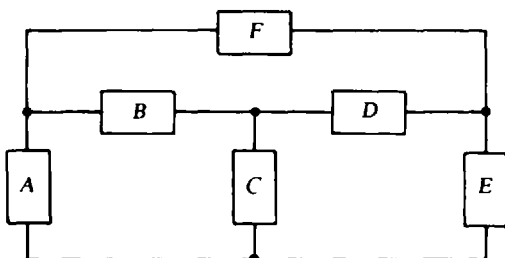

Fig. 3-5

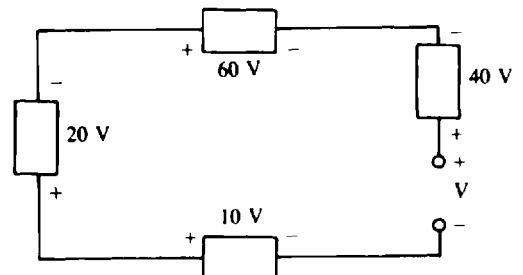

Fig. 3-6

3.6 Find the unknown voltages in the circuit shown in Fig. 3-7. Find V_1 first.

The basic KVL approach is to use loops having only one unknown voltage apiece. Such a loop for V_1 includes the 10-, 8-, and 9-V components. The sum of the voltage drops in a clockwise direction around this loop is

$$10 - 8 + 9 - V_1 = 0 \quad \text{from which} \quad V_1 = 11 \text{ V}$$

Similarly, for V_2 the sum of the voltage drops clockwise around the top mesh is

$$V_2 + 8 - 10 = 0 \quad \text{from which} \quad V_2 = 2 \text{ V}$$

Clockwise around the bottom mesh, the sum of the voltage drops is

$$-8 + 9 + V_3 = 0 \quad \text{from which} \quad V_3 = -1 \text{ V}$$

The negative sign for V_3 indicates that the polarity of the actual voltage is opposite the reference polarity.

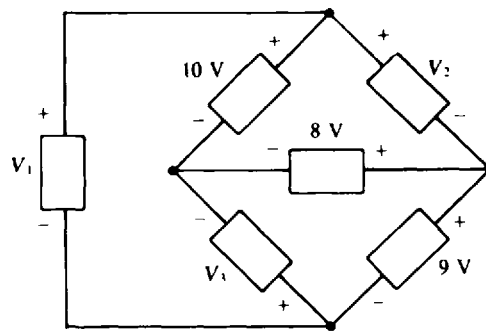

Fig. 3-7

3.7 What is the total resistance of 2-, 5-, 8-, 10-, and 17- Ω resistors connected in series?

The total resistance of series resistors is the sum of the individual resistances: $R_T = 2 + 5 + 8 + 10 + 17 = 42 \Omega$.

3.8 What is the total resistance of thirty 6- Ω resistors connected in series?

The total resistance is the number of resistors times the common resistance of 6 Ω : $R_T = 30 \times 6 = 180 \Omega$.

3.9 What is the total conductance of 4-, 10-, 16-, 20-, and 24-S resistors connected in series?

The best approach is to convert the conductances to resistances, add the resistances to get the total resistance, and then invert the total resistance to get the total conductance:

$$R_T = \frac{1}{4} + \frac{1}{10} + \frac{1}{16} + \frac{1}{20} + \frac{1}{24} = 0.504 \Omega$$

and

$$G_T = \frac{1}{R_T} = \frac{1}{0.504} = 1.98 \text{ S}$$

3.10 A string of Christmas tree lights consists of eight 6-W, 15-V bulbs connected in series. What current flows when the string is plugged into a 120-V outlet, and what is the hot resistance of each bulb?

The total power is $P_T = 8 \times 6 = 48 \text{ W}$. From $P_T = VI$, the current is $I = P_T/V = 48/120 = 0.4 \text{ A}$. And from $P = I^2R$, the hot resistance of each bulb is $R = P/I^2 = 6/0.4^2 = 37.5 \Omega$.

- 3.11** A 3-V, 300-mA flashlight bulb is to be used as the dial light in a 120-V radio. What is the resistance of the resistor that should be connected in series with the flashlight bulb to limit the current?

Since 3 V is to be across the flashlight bulb, there will be $120 - 3 = 117$ V across the series resistor. The current is the rated 300 mA. Consequently, the resistance is $117/0.3 = 390 \Omega$.

- 3.12** A person wants to move a 20-W FM-AM transistor radio from a junked car with a 6-V battery to a new car with a 12-V battery. What is the resistance of the resistor that should be connected in series with the radio to limit the current, and what is its minimum power rating?

From $P = VI$, the radio requires $20/6 = 3.33$ A. The resistor, being in series, has the same current. Also, it has the same voltage because $12 - 6 = 6$ V. As a result, $R = 6/3.33 = 1.8 \Omega$. With the same voltage and current, the resistor must dissipate the same power as the radio, and so has a 20-W minimum power rating.

- 3.13** A series circuit consists of a 240-V source and 12-, 20-, and 16- Ω resistors. Find the current out of the positive terminal of the voltage source. Also find the resistor voltages. Assume associated references, as should always be done when there is no specification of references.

The current is the applied voltage divided by the equivalent resistance:

$$I = \frac{240}{12 + 20 + 16} = 5 \text{ A}$$

Each resistor voltage is this current times the corresponding resistance: $V_{12} = 5 \times 12 = 60$ V, $V_{20} = 5 \times 20 = 100$ V, and $V_{16} = 5 \times 16 = 80$ V. As a check, the sum of the resistor voltages is $60 + 100 + 80 = 240$ V, the same as the applied voltage.

- 3.14** A resistor in series with an 8- Ω resistor absorbs 100 W when the two are connected across a 60-V line. Find the unknown resistance R .

The total resistance is $8 + R$, and thus the current is $60/(8 + R)$. From $I^2 R = P$,

$$\left(\frac{60}{8 + R}\right)^2 R = 100 \quad \text{or} \quad 3600R = 100(8 + R)^2$$

which simplifies to $R^2 - 20R + 64 = 0$. The quadratic formula can be used to find R . Recall that for the equation $ax^2 + bx + c = 0$, this formula is

$$x = \frac{-b \pm \sqrt{b^2 - 4ac}}{2a}$$

$$\text{So} \quad R = \frac{-(-20) \pm \sqrt{(-20)^2 - 4(1)(64)}}{2(1)} = \frac{20 \pm 12}{2} = 16 \Omega \text{ or } 4 \Omega$$

A resistor with a resistance of either 16 or 4 Ω will dissipate 100 W when connected in series with an 8- Ω resistor across a 60-V line.

This particular quadratic equation can be factored without using the quadratic formula. By inspection, $R^2 - 20R + 64 = (R - 16)(R - 4) = 0$, from which $R = 16 \Omega$ or $R = 4 \Omega$, the same as before.

- 3.15** Resistors R_1 , R_2 , and R_3 are in series with a 100-V source. The total voltage drop across R_1 and R_2 is 50 V, and that across R_2 and R_3 is 80 V. Find the three resistances if the total resistance is 50 Ω .

The current is the applied voltage divided by the total resistance: $I = 100/50 = 2$ A. Since the voltage across resistors R_1 and R_2 is 50 V, there must be $100 - 50 = 50$ V across R_3 . By Ohm's law, $R_3 = 50/2 =$

25 Ω . Resistors R_2 and R_3 have 80 V across them, leaving $100 - 80 = 20$ V across R_1 . Thus, $R_1 = 20/2 = 10 \Omega$. The resistance of R_2 is the total resistance minus the resistances of R_1 and R_3 : $R_2 = 50 - 10 - 25 = 15 \Omega$.

- 3.16** What is the maximum voltage that can be applied across the series combination of a 150- Ω , 2-W resistor and a 100- Ω , 1-W resistor without exceeding the power rating of either resistor?

From $P = I^2 R$, the maximum safe current for the 150- Ω resistor is $I = \sqrt{P/R} = \sqrt{2/150} = 0.115$ A. That for the 100- Ω resistor is $\sqrt{1/100} = 0.1$ A. The maximum current cannot exceed the lesser of these two currents and so is 0.1 A. For this current, $V = I(R_1 + R_2) = 0.1(150 + 100) = 25$ V.

- 3.17** In a series circuit, a current flows from the positive terminal of a 180-V source through two resistors, one of which has 30 Ω of resistance and the other of which has 45 V across it. Find the current and the unknown resistance.

The 30- Ω resistor has $180 - 45 = 135$ V across it and thus a $135/30 = 4.5$ -A current through it. The other resistance is $45/4.5 = 10 \Omega$.

- 3.18** Find the current and unknown voltages in the circuit shown in Fig. 3-8.

The total resistance is the sum of the resistances: $10 + 15 + 6 + 8 + 11 = 50 \Omega$. The total voltage rise from the voltage sources in the direction of I is $12 - 5 + 8 = 15$ V. The current I is this voltage divided by the total resistance: $I = 15/50 = 0.3$ A. By Ohm's law, $V_1 = 0.3 \times 10 = 3$ V, $V_2 = 0.3 \times 15 = 4.5$ V, $V_3 = -0.3 \times 6 = -1.8$ V, $V_4 = 0.3 \times 8 = 2.4$ V, and $V_5 = -0.3 \times 11 = -3.3$ V. The equations for V_3 and V_5 have negative signs because the references for these voltages and the reference for I are not associated.

- 3.19** Find the voltage V_{ab} in the circuit shown in Fig. 3-8.

V_{ab} is the voltage drop from node a to node b , which is the sum of the voltage drops across the components connected between nodes a and b either to the right or to the left of node a . It is convenient to choose the path to the right because this is the direction of the $I = 0.3$ -A current found in the solution of Prob. 3.18. Thus,

$$V_{ab} = (0.3 \times 15) + 5 + (0.3 \times 6) + (0.3 \times 8) - 8 = 5.7 \text{ V}$$

Note that an IR drop is always positive in the direction of I . A voltage reference, and that of V_3 in particular here, has no effect on this.

- 3.20** Find I_1 , I_2 , and V in the circuit shown in Fig. 3-9.

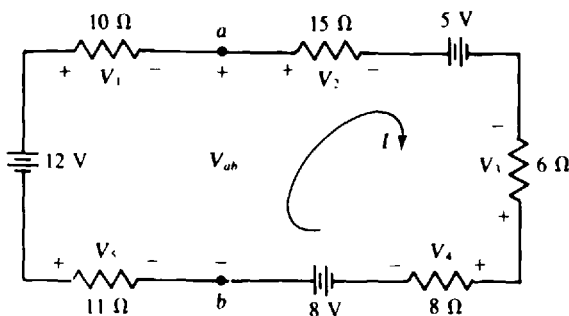

Fig. 3-8

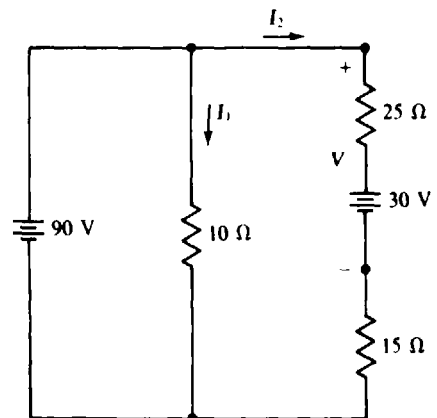

Fig. 3-9

Since the 90-V source is across the 10-Ω resistor, $I_1 = 90/10 = 9$ A. Around the outside loop in a clockwise direction, the voltage drop across the two resistors is $(25 + 15)I_2 = 40I_2$. This is equal to the sum of the voltage rises across the voltage sources in this outside loop:

$$40I_2 = -30 + 90 \quad \text{from which} \quad I_2 = 60/40 = 1.5 \text{ A}$$

The voltage V is equal to the sum of the drops across the 25-Ω resistor and the 30-V source: $V = (1.5 \times 25) + 30 = 67.5$ V. Notice that the parallel 10-Ω resistor does not affect I_2 . In general, resistors in parallel with voltage sources that have zero internal resistances (ideal voltage sources) do not affect currents or voltages elsewhere in a circuit. They do, however, cause an increase in current flow in these voltage sources.

3.21 A 90-V source is in series with five resistors having resistances of 4, 5, 6, 7, and 8 Ω. Find the voltage across the 6-Ω resistor. (Here “voltage” refers to the positive voltage, as it will in later problems unless otherwise indicated. The same is true for current.)

By the voltage division formula, the voltage across a resistor in a series circuit equals the resistance of that resistor times the applied voltage divided by the total resistance. So,

$$V_6 = \frac{6}{4 + 5 + 6 + 7 + 8} \times 90 = 18 \text{ V}$$

3.22 Use voltage division to determine the voltages V_4 and V_5 in the circuit shown in Fig. 3-8.

The total voltage applied across the resistors equals the sum of the voltage rises from the voltage sources, preferably in a clockwise direction: $12 - 5 + 8 = 15$ V. The polarity of this net voltage is such that it produces a clockwise current flow. In this sum the 5 V is negative because it is a drop, and rises are being added. Put another way, the polarity of the 5-V source opposes the polarities of the 12- and 8-V sources. The V_4 voltage division formula should have a positive sign because V_4 is a drop in the clockwise direction—it opposes the polarity of the net applied voltage:

$$V_4 = \frac{8}{10 + 15 + 6 + 8 + 11} \times 15 = \frac{8}{50} \times 15 = 2.4 \text{ V}$$

The voltage division formula for V_5 requires a negative sign because both V_5 and the net source voltage are rises in the clockwise direction:

$$V_5 = -\frac{11}{50} \times 15 = -3.3 \text{ V}$$

3.23 Find the voltage V_{ab} across the open circuit in the circuit shown in Fig. 3-10.

The 10-Ω resistor has zero current flowing through it because it is in series with an open circuit. (Also, it has zero volts across it.) Consequently, voltage division can be used to obtain V_1 . The result is

$$V_1 = \frac{60}{60 + 40} \times 100 = 60 \text{ V}$$

Then, a summation of voltage drops around the right-hand half of the circuit gives $0 - 30 + V_{ab} + 10 - 60 = 0$. Therefore, $V_{ab} = 80$ V.

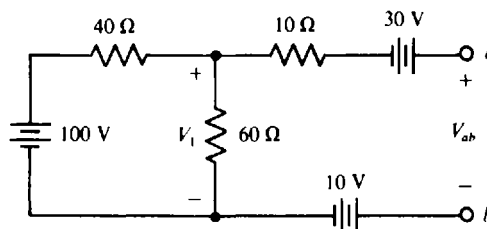

Fig. 3-10

3.24 For the circuit of Fig. 3-11, calculate I and the power absorbed by the dependent source.

A good first step is to solve for the controlling quantity V_1 in terms of I . Applying Ohm's law to the $4\text{-}\Omega$ resistor gives $V_1 = 4I$. Consequently, in the direction of I , the voltage rise across the dependent source is $4.5(4I) = 18I$. Then by KVL,

$$4I + 2I - 18I = 24 \quad \text{and so} \quad I = 24/(-12) = -2 \text{ A}$$

The negative sign indicates that the 2-A current flows counterclockwise, opposite the reference direction for I .

Since the current and voltage references for the dependent source are not associated, the power absorbed formula has a negative sign:

$$P = -4.5V_1(I) = -4.5(4I)(I) = -18I^2$$

But $I = -2 \text{ A}$, and so $P = -18(-2)^2 = -72 \text{ W}$. The presence of the negative sign means that the dependent source is supplying power instead of absorbing it.

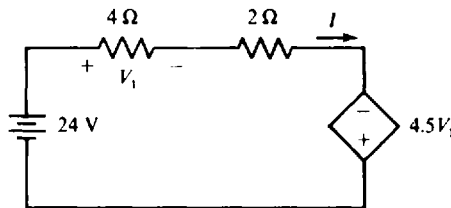

Fig. 3-11

3.25 In the circuit of Fig. 3-11, determine the resistance “seen” by the independent voltage source.

The resistance “seen” by the source is equal to the ratio of the source voltage to the current that flows out of the positive terminal of the source:

$$R = \frac{24}{I} = \frac{24}{-2} = -12 \text{ }\Omega$$

The negative sign of the resistance is a result of the action of the dependent source. It indicates that the remainder of the circuit supplies power to the independent source. Actually, it is the dependent source alone that supplies this power, as well as the power to the two resistors.

3.26 Find V_1 in the circuit of Fig. 3-12.

First observe that no current flows in the single wire connecting the two halves of this circuit, as is evident from enclosing either half in a closed surface. Then only this single wire would cross this surface, and since the sum of the currents leaving any closed surface must be zero, the current in this wire must be zero. From another point of view, there is no return path for a current that would flow in this wire

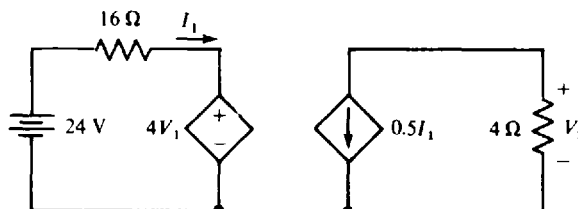

Fig. 3-12

From KVL applied to the left-hand half of the circuit, $16I_1 + 4V_1 = 24$. And for the right-hand half of the circuit, Ohm's law gives

$$V_1 = -0.5I_1(4) = -2I_1 \quad \text{or} \quad I_1 = -0.5V_1$$

Then, substituting for I_1 in the KVL equation produces

$$16(-0.5V_1) + 4V_1 = 24 \quad \text{and so} \quad V_1 = -6 \text{ V}$$

3.27 Calculate I and V_{ab} in the circuit of Fig. 3-13.

Because of the open circuit between nodes a and b , the middle branch has no effect on the current I . Consequently, I can be obtained by applying KVL to the outside loop. The total resistance of this loop is $2 + 8 + 5 + 9 = 24 \Omega$. And in the direction of I , the sum of the voltage rises from voltage sources is $100 + 20 = 120 \text{ V}$. So, $I = 120/24 = 5 \text{ A}$.

From the summing of voltage drops across the right-hand branch, the voltage drop, top to bottom, across the middle branch is $5(5) - 20 + 5(9) = 50 \text{ V}$. Consequently, $V_{ab} = 50 - 30 = 20 \text{ V}$ because there is zero volts across the $10\text{-}\Omega$ resistor.

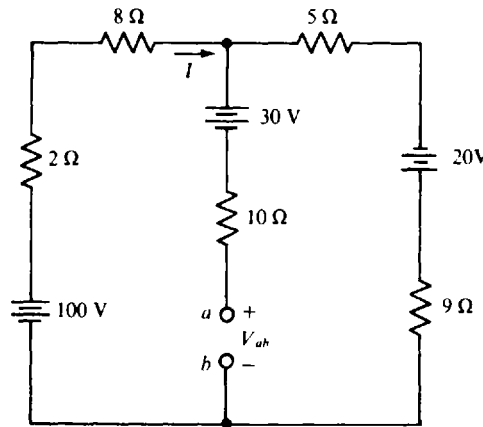

Fig. 3-13

3.28 Determine the voltage drop V_{ab} across the open circuit in the circuit of Fig. 3-14.

Because of the open circuit, no current flows in the $9\text{-}\Omega$ and $13\text{-}\Omega$ resistors and so there is zero volts across each of them. Also, then, all the 6-A source current flows through the $10\text{-}\Omega$ resistor and all the 8-A

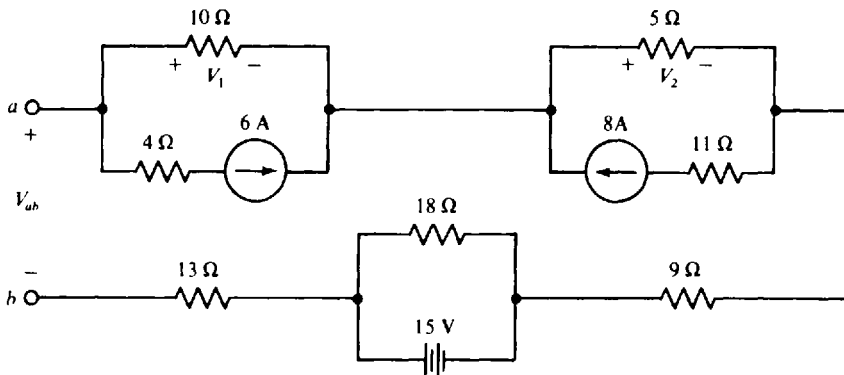

Fig. 3-14

source current flows through the $5\text{-}\Omega$ resistor, making $V_1 = -6(10) = -60\text{ V}$ and $V_2 = 8(5) = 40\text{ V}$, respectively. So, V_{ab} , the voltage drop from node a to b , is from summing voltage drops,

$$V_{ab} = V_1 + V_2 + 0 - 15 + 0 = -60 + 40 - 15 = -35\text{ V}$$

The 4- , 11- , 9- , 18- , and $13\text{-}\Omega$ resistors have no effect on this result.

3.29 Find the unknown currents in the circuit shown in Fig. 3-15. Find I_1 , first.

The basic KCL approach is to find closed surfaces such that only one unknown current flows across each surface. In Fig. 3-15, the large dashed loop represents a closed surface drawn such that I_1 is the only unknown current flowing across it. Other currents flowing across it are the 10- , 8- , and 9-A currents. I_1 and the 9-A currents leave this closed surface, and the 8-A and 10-A currents enter it. By KCL, the sum of the currents leaving is zero: $I_1 + 9 - 8 - 10 = 0$, or $I_1 = 9\text{ A}$. I_2 is readily found from summing the currents leaving the middle top node: $I_2 - 8 - 10 = 0$, or $I_2 = 18\text{ A}$. Similarly, at the right top node, $I_3 + 8 - 9 = 0$, and $I_3 = 1\text{ A}$. Checking at the left top node: $10 - I_1 - I_3 = 10 - 9 - 1 = 0$, as it should be.

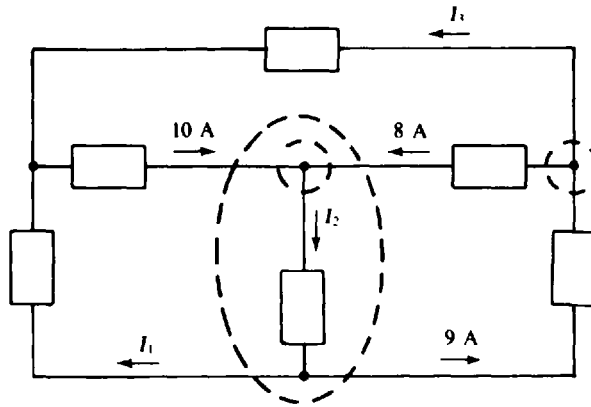

Fig. 3-15

3.30 Find I for the circuit shown in Fig. 3-16.

Since I is the only unknown current flowing across the shown dashed loop, it can be found by setting to zero the sum of the currents leaving this loop: $I - 16 - 8 - 9 + 3 + 2 - 10 = 0$, from which $I = 38\text{ A}$.

3.31 Find the short-circuit current I_3 for the circuit shown in Fig. 3-17.

The short circuit places the 100 V of the left-hand voltage source across the $20\text{-}\Omega$ resistor, and it places the 200 V of the right-hand source across the $25\text{-}\Omega$ resistor. By Ohm's law, $I_1 = 100/20 = 5\text{ A}$ and $I_2 = -200/25 = -8\text{ A}$. The negative sign occurs in the I_2 formula because of nonassociated references.

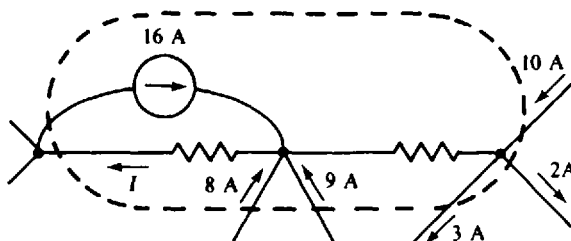

Fig. 3-16

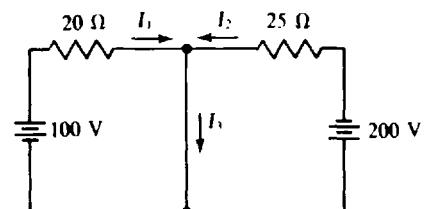

Fig. 3-17

From KCL applied at the top middle node, $I_3 = I_1 + I_2 = 5 - 8 = -3$ A. Of course the negative sign in the answer means that 3 A actually flows up through the short circuit, opposite the direction of the I_3 current reference arrow.

3.32 Calculate V in the circuit of Fig. 3-18.

The short circuit places all 36 V of the voltage source across the 20-k Ω resistor. So, by Ohm's law, $I_1 = 36/20 = 1.8$ mA. (The kilohm-milliampere method was used in finding I_1 .) Applying KCL to the top middle node gives

$$I_2 = I_1 + 10I_2 = 1.8 + 10I_2 \quad \text{and therefore} \quad I_2 = -0.2 \text{ mA}$$

Finally, by Ohm's law,

$$V = -5(10I_2) = -5(-2) = 10 \text{ V}$$

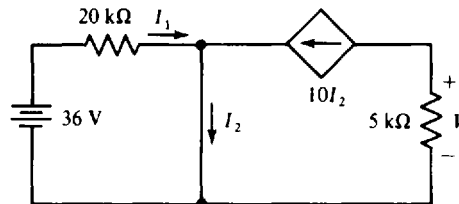

Fig. 3-18

3.33 Find the total conductance and resistance of four parallel resistors having resistances of 1, 0.5, 0.25, and 0.125 Ω .

The total conductance is the sum of the individual conductances:

$$G_T = \frac{1}{1} + \frac{1}{0.5} + \frac{1}{0.25} + \frac{1}{0.125} = 1 + 2 + 4 + 8 = 15 \text{ S}$$

The total resistance is the inverse of this total conductance: $R_T = 1/G_T = 1/15 = 0.0667 \Omega$.

3.34 Find the total resistance of fifty 200- Ω resistors connected in parallel.

The total resistance equals the common resistance divided by the number of resistors: $200/50 = 4 \Omega$.

3.35 A resistor is to be connected in parallel with a 10-k Ω resistor and a 20-k Ω resistor to produce a total resistance of 12 k Ω . What is the resistance of the resistor?

Assuming that the added resistor is a conventional resistor, no added parallel resistor will give a total resistance of 12 k Ω because the total resistance of parallel resistors is always less than the least individual resistance, which is 10 k Ω . With transistors, however, it is possible to make a component that has a negative resistance and that in parallel can cause an increase in total resistance. Generally, however, the term *resistor* means a conventional resistor that has only positive resistance.

3.36 Three parallel resistors have a total conductance of 1.75 S. If two of the resistances are 1 and 2 Ω , what is the third resistance?

The sum of the individual conductances equals the total conductance:

$$\frac{1}{1} + \frac{1}{2} + G_3 = 1.75 \quad \text{or} \quad G_3 = 1.75 - 1.5 = 0.25 \text{ S}$$

The resistance of the third resistor is the inverse of this conductance: $R_3 = 1/G_3 = 1/0.25 = 4 \Omega$.

- 3.37** Without using conductances, find the total resistance of two parallel resistors having resistances of 5 and 20 Ω .

The total resistance equals the product of the individual resistances divided by the sum: $R_T = (5 \times 20)/(5 + 20) = 100/25 = 4 \Omega$.

- 3.38** Repeat Prob. 3.37 for three parallel resistors having resistances of 12, 24, and 32 Ω .

One approach is to consider the resistances two at a time. For the 12- and the 24- Ω resistances, the equivalent resistance is

$$\frac{12 \times 24}{12 + 24} = \frac{288}{36} = 8 \Omega$$

This combined with the 32- Ω resistance gives a total resistance of

$$R_T = \frac{8 \times 32}{8 + 32} = \frac{256}{40} = 6.4 \Omega$$

- 3.39** A 60-W, a 100-W, and a 200-W light bulb are connected in parallel across a 120-V line. Obtain the equivalent hot resistance of this combination from the individual hot resistances of the bulbs.

From $R = V^2/P$, the individual resistances are $120^2/60 = 240 \Omega$, $120^2/100 = 144 \Omega$, and $120^2/200 = 72 \Omega$. The 72- and 144- Ω resistances have an equivalent resistance of $(72 \times 144)/(72 + 144) = 48 \Omega$. The equivalent resistance of this and the 240- Ω resistance is the total equivalent hot resistance: $(240 \times 48)/(240 + 48) = 40 \Omega$. As a check, from the total power of 360 W, $R_T = V^2/P = 120^2/360 = 40 \Omega$.

- 3.40** Determine R_T in $R_T = (4 + 24 \parallel 12) \parallel 6$.

It is essential to start evaluating inside the parentheses, and then work out. By definition, the term $24 \parallel 12 = (24 \times 12)/(24 + 12) = 8$. This adds to the 4: $4 + 8 = 12$. The expression reduces to $12 \parallel 6$, which is $(12 \times 6)/(12 + 6) = 4$. Thus, $R_T = 4 \Omega$.

- 3.41** Find the total resistance R_T of the resistor ladder network shown in Fig. 3-19.

To find the equivalent resistance of a ladder network by combining resistances, always start at the end opposite the input terminals. At this end, the series 4- and 8- Ω resistors have an equivalent resistance of 12 Ω . This combines in parallel with the 24- Ω resistance: $(24 \times 12)/(24 + 12) = 8 \Omega$. This adds to the 3 and the 9 Ω of the series resistors for a sum of $8 + 3 + 9 = 20 \Omega$. This combines in parallel with the 5- Ω resistance: $(20 \times 5)/(20 + 5) = 4 \Omega$. R_T is the sum of this resistance and the resistances of the series 16- and 14- Ω resistors: $R_T = 4 + 16 + 14 = 34 \Omega$.

- 3.42** In the circuit shown in Fig. 3-20 find the total resistance R_T with terminals a and b (a) open-circuited, and (b) short-circuited.

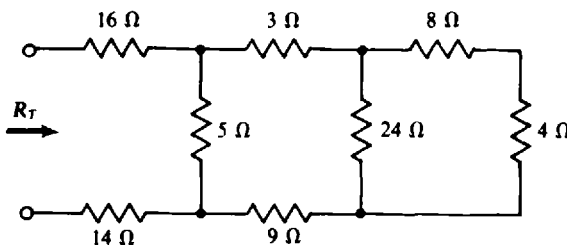

Fig. 3-19

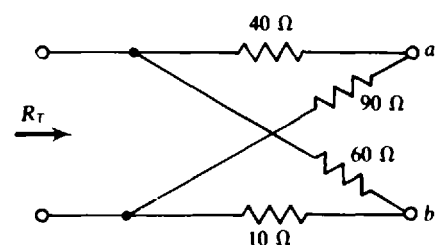

Fig. 3-20

- (a) With terminals *a* and *b* open, the 40- and 90-Ω resistors are in series, as are the 60- and 10-Ω resistors. The two series combinations are in parallel; so

$$R_T = \frac{(40 + 90)(60 + 10)}{40 + 90 + 60 + 10} = 45.5 \Omega$$

- (b) For terminals *a* and *b* short-circuited, the 40- and 60-Ω resistors are in parallel, as are the 90- and 10-Ω resistors. The two parallel combinations are in series, making

$$R_T = \frac{40 \times 60}{40 + 60} + \frac{90 \times 10}{90 + 10} = 33 \Omega$$

- 3.43** A 90-A current flows into four parallel resistors having resistances of 5, 6, 12, and 20 Ω. Find the current in each resistor.

The total resistance is

$$R_T = \frac{1}{1/5 + 1/6 + 1/12 + 1/20} = 2 \Omega$$

This value times the current gives the voltage across the parallel combination: $2 \times 90 = 180 \text{ V}$. Then by Ohm's law, $I_5 = 180/5 = 36 \text{ A}$, $I_6 = 180/6 = 30 \text{ A}$, $I_{12} = 180/12 = 15 \text{ A}$, and $I_{20} = 180/20 = 9 \text{ A}$.

- 3.44** Find the voltage and unknown currents in the circuit shown in Fig. 3-21.

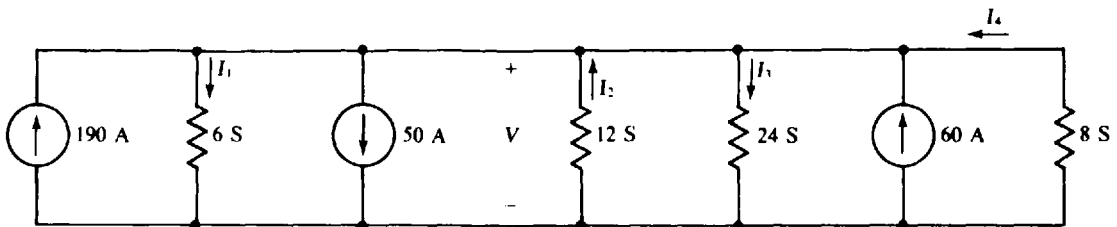

Fig. 3-21

Even though it has several dots, the top line is just a single node because the entire line is at the same potential. The same is true of the bottom line. Thus, there are just two nodes and one voltage V . The total conductance of the parallel-connected resistors is $G = 6 + 12 + 24 + 8 = 50 \text{ S}$. Also, the total current entering the top node from current sources is $190 - 50 + 60 = 200 \text{ A}$. This conductance and current can be used in the conductance version of Ohm's law, $I = GV$, to obtain the voltage: $V = I/G = 200/50 = 4 \text{ V}$. Since this is the voltage across each resistor, the resistor currents are $I_1 = 6 \times 4 = 24 \text{ A}$, $I_2 = -12 \times 4 = -48 \text{ A}$, $I_3 = 24 \times 4 = 96 \text{ A}$, and $I_4 = -8 \times 4 = -32 \text{ A}$. The negative signs are the result of non-associated references. Of course, all the actual resistor currents leave the top node.

Note that the parallel current sources have the same effect as a single current source, the current of which is the algebraic sum of the individual currents from the sources.

- 3.45** Use current division to find the currents I_2 and I_3 in the circuit shown in Fig. 3-21.

The sum of the currents from current sources into the top node is $190 - 50 + 60 = 200 \text{ A}$. Also, the sum of the conductances is $6 + 12 + 24 + 8 = 50 \text{ S}$. By the current division formula,

$$I_2 = -\frac{12}{50} \times 200 = -48 \text{ A} \quad \text{and} \quad I_3 = \frac{24}{50} \times 200 = 96 \text{ A}$$

The formula for I_2 has a negative sign because I_2 has a reference into the top node, and the sum of the currents from current sources is also into the top node. For a positive sign, one current in the formula must be into a node and the other current must be out of the same node.

- 3.46** A 90-A current flows into two parallel resistors having resistances of 12 and 24 Ω . Find the current in the 24- Ω resistor.

The current in the 24- Ω resistor equals the resistance of the other parallel resistor divided by the sum of the resistances, all times the input current:

$$I_{24} = \frac{12}{12 + 24} \times 90 = 30 \text{ A}$$

As a check, this current results in a voltage of $30 \times 24 = 720 \text{ V}$, which is also across the 12- Ω resistor. Thus, $I_{12} = 720/12 = 60 \text{ A}$, and $I_{24} + I_{12} = 30 + 60 = 90 \text{ A}$, which is the input current.

- 3.47** Calculate V_1 and V_2 in the circuit of Fig. 3-22.

A good first step is to solve for the controlling current I in terms of V_1 : $I = V_1/5$. Thus, the dependent source current is, in terms of V_1 , $3(V_1/5) = 0.6V_1$, directed downward. Then, KCL applied at the top right-hand node gives

$$\frac{V_1}{5} + \frac{V_1}{10} + 0.6V_1 = 9 \quad \text{from which} \quad V_1 = 10 \text{ V}$$

The voltage drop across the 12- Ω resistor is $9(12) = 108 \text{ V}$. Finally, KVL applied around the outside loop results in $V_2 = 108 + 10 = 118 \text{ V}$. Observe that the 12- Ω resistor has no effect on V_1 , but it does have an effect on V_2 .

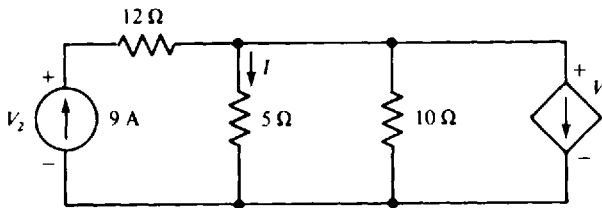

Fig. 3-22

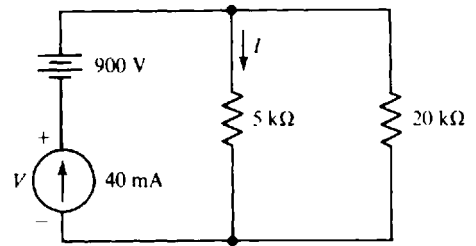

Fig. 3-23

- 3.48** Calculate I and V in the circuit of Fig. 3-23.

The source current of 40 mA flows into the parallel resistors. So, by current division,

$$I = \frac{20}{20 + 5} \times 40 = 32 \text{ mA}$$

Then by KVL, $V = -900 + 32(5) = -740 \text{ V}$. Observe that although the voltage-source voltage has an effect on the current-source voltage, it has no effect on the resistor current I .

- 3.49** Use voltage division twice to find V_1 in the circuit shown in Fig. 3-24.

Clearly, V_1 can be found from V_2 by voltage division. And V_2 can be found from the source voltage by voltage division used with the equivalent resistance to the right of the 16- Ω resistor. This resistance is

$$\frac{(54 + 18)(36)}{54 + 18 + 36} = 24 \Omega$$

By voltage division,

$$V_2 = \frac{24}{16 + 24} \times 80 = 48 \text{ V} \quad \text{and} \quad V_1 = \frac{18}{54 + 18} \times 48 = 12 \text{ V}$$

A common error in finding V_2 is to neglect the loading of the resistors to the right of the V_2 node.

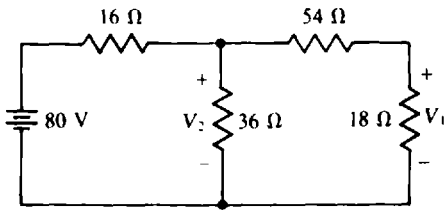

Fig. 3-24

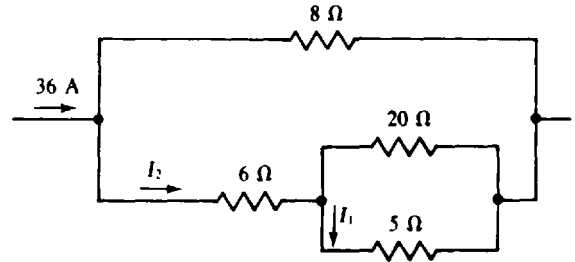

Fig. 3-25

3.50 Use current division twice to find I_1 in the circuit shown in Fig. 3-25.

Obviously I_1 can be found from I_2 by current division. And, if the total resistance of the bottom three branches is found, current division can be used to find I_2 from the input current. The needed total resistance is

$$6 + \frac{20 \times 5}{20 + 5} = 10 \Omega$$

By the two-resistance form of the current division formula,

$$I_2 = \frac{8}{10 + 8} \times 36 = 16 \text{ A} \quad \text{and} \quad I_1 = \frac{20}{20 + 5} \times 16 = 12.8 \text{ A}$$

Supplementary Problems

3.51 Determine the number of nodes, branches, loops, and meshes in the circuit shown in Fig. 3-26.

Ans. 6 nodes, 8 branches, 7 loops, 3 meshes

3.52 Find V_1 , V_2 , and V_3 for the circuit shown in Fig. 3-26.

Ans. $V_1 = 26 \text{ V}$, $V_2 = -21 \text{ V}$, $V_3 = 2 \text{ V}$

3.53 Four resistors in series have a total resistance of 500Ω . If three of the resistors have resistances of 100, 150, and 200Ω , what is the resistance of the fourth resistor?

Ans. 50Ω

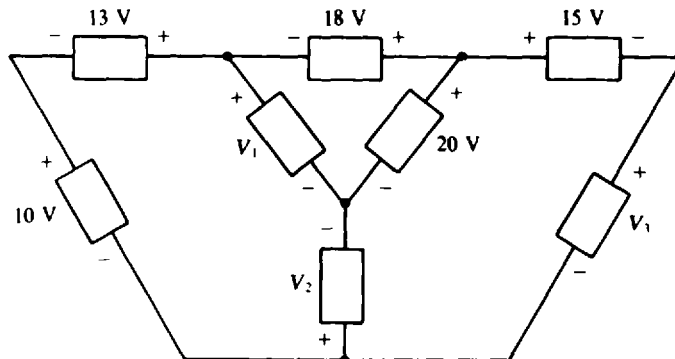

Fig. 3-26

- 3.54** Find the total conductance of 2-, 4-, 8-, and 10-S resistors connected in series.
Ans. 1.03 S
- 3.55** A 60-W, 120-V light bulb is to be connected in series with a resistor across a 277-V line. What is the resistance and minimum power rating of the resistor required if the light bulb is to operate under rated conditions?
Ans. 314 Ω , 78.5 W
- 3.56** A series circuit consists of a dc voltage source and 4-, 5-, and 6- Ω resistors. If the current is 7 A, find the source voltage.
Ans. 105 V
- 3.57** A 12-V battery with a 0.3- Ω internal resistance is to be charged from a 15-V source. If the charging current should not exceed 2 A, what is the minimum resistance of a series resistor that will limit the current to this safe value?
Ans. 1.2 Ω
- 3.58** A resistor in series with a 100- Ω resistor absorbs 80 W when the two are connected across a 240-V line. Find the unknown resistance.
Ans. 20 or 500 Ω
- 3.59** A series circuit consists of a 4-V source and 2-, 4-, and 6- Ω resistors. What is the minimum power rating of each resistor if the resistors are available in power ratings of $\frac{1}{2}$ W, 1 W, and 2 W?
Ans. $P_2 = \frac{1}{2}$ W, $P_4 = \frac{1}{2}$ W, $P_6 = 1$ W
- 3.60** Find V_{ab} in the circuit shown in Fig. 3-27.
Ans. 20 V

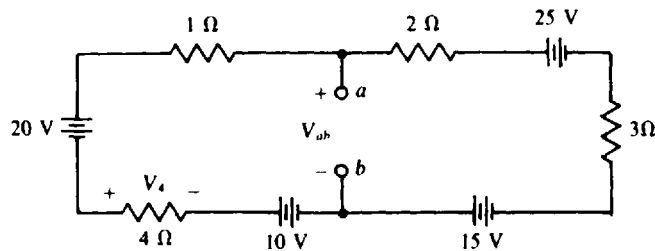

Fig. 3-27

- 3.61** Use voltage division to find the voltage V_4 in the circuit shown in Fig. 3-27.
Ans. -8 V
- 3.62** A series circuit consists of a 100-V source and 4-, 5-, 6-, 7-, and 8- Ω resistors. Use voltage division to determine the voltage across the 6- Ω resistor.
Ans. 20 V
- 3.63** Determine I in the circuit of Fig. 3-28.
Ans. 3 A
- 3.64** Find V across the open circuit in the circuit of Fig. 3-29.
Ans. -45 V

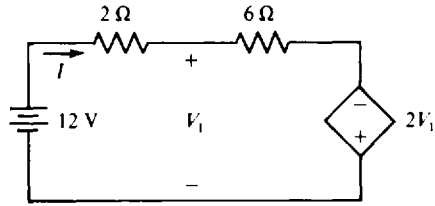

Fig. 3-28

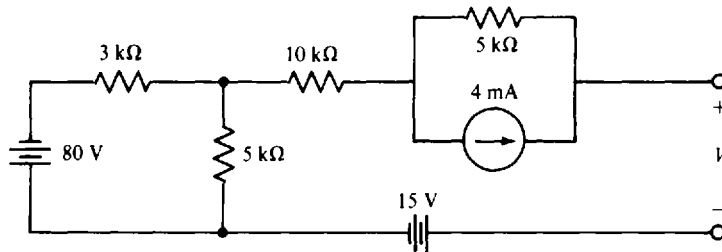

Fig. 3-29

3.65 Find the indicated unknown currents in the circuits shown in Fig. 3-30.

Ans. $I_1 = 2\text{ A}$, $I_2 = -6\text{ A}$, $I_3 = -5\text{ A}$, $I_4 = 3\text{ A}$

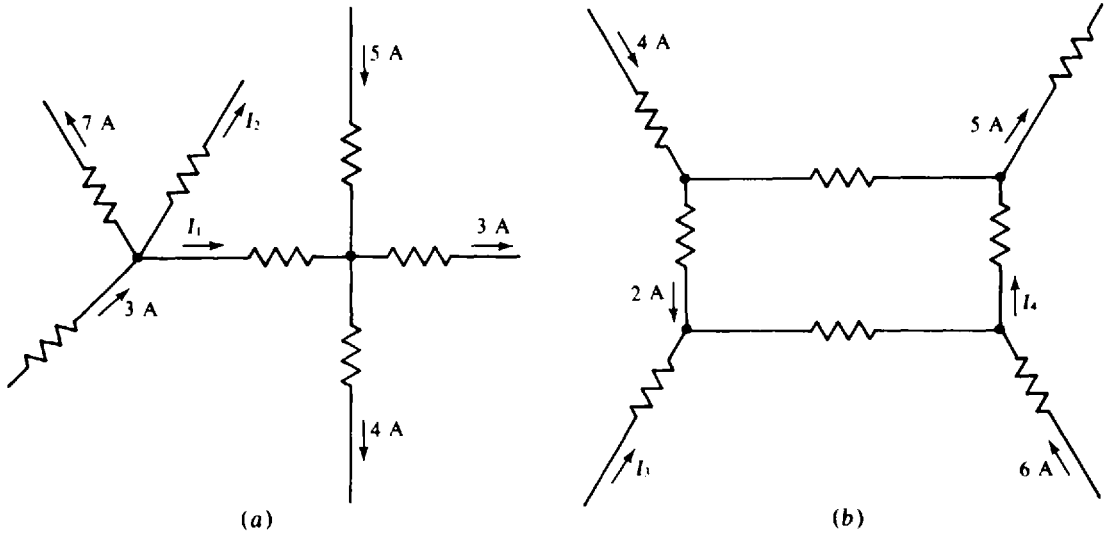

Fig. 3-30

3.66 Find the short-circuit current I in the circuit shown in Fig. 3-31.

Ans. 3 A

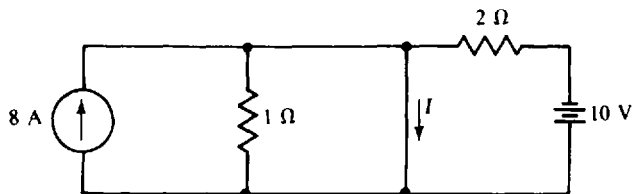

Fig. 3-31

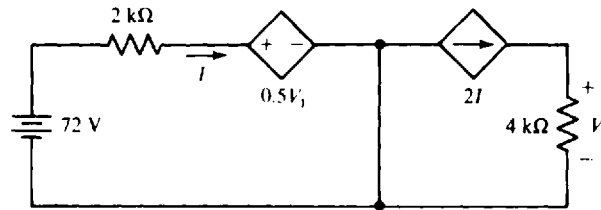

Fig. 3-32

3.67 Calculate V_1 in the circuit of Fig. 3-32.

Ans. 96 V

3.68 What are the different resistances that can be obtained with three 4- Ω resistors?

Ans. 1.33, 2, 2.67, 4, 6, 8, and 12 Ω

3.69 A 100- Ω resistor and another resistor in parallel have an equivalent resistance of 75 Ω . What is the resistance of the other resistor?

Ans. 300 Ω

3.70 Find the equivalent resistance of four parallel resistors having resistances of 2, 4, 6, and 8 Ω .

Ans. 0.96 Ω

3.71 Three parallel resistors have a total conductance of 2 mS. If two of the resistances are 1 and 5 k Ω , what is the third resistance?

Ans. 1.25 k Ω

3.72 The equivalent resistance of three parallel resistors is 10 Ω . If two of the resistors have resistances of 40 and 60 Ω , what is the resistance of the third resistor?

Ans. 17.1 Ω

3.73 Determine R_T in $R_T = (24 \parallel 48 + 24) \parallel 10$.

Ans. 8 Ω

3.74 Determine R_T in $R_T = (6 \parallel 12 + 10 \parallel 40) \parallel (6 + 2)$.

Ans. 4.8 Ω

3.75 Find the total resistance R_T of the resistor ladder network shown in Fig. 3-33.

Ans. 26.6 k Ω

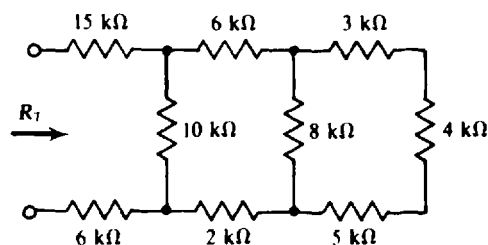

Fig. 3-33

3.76 Repeat Prob. 3.75 with all resistances doubled.

Ans. 53.2 k Ω

3.77 In the circuit shown in Fig. 3-34, find R_T with terminals a and b (a) open-circuited, and (b) short-circuited.

Ans. (a) 18.2 Ω , (b) 18.1 Ω

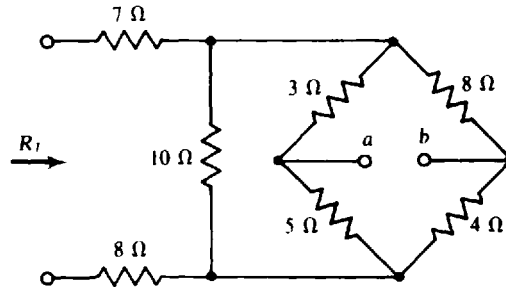

Fig. 3-34

3.78 A 15-mA current flows into four parallel resistors having resistances of 4, 6, 8, and 12 k Ω . Find each resistor current.

Ans. $I_4 = 6$ mA, $I_6 = 4$ mA, $I_8 = 3$ mA, $I_{12} = 2$ mA

3.79 Repeat Prob. 3.78 with all resistances doubled.

Ans. Same currents

3.80 Find the unknown currents in the circuit shown in Fig. 3-35.

Ans. $I_1 = -10$ A, $I_2 = -8$ A, $I_3 = 6$ A, $I_4 = -2$ A, $I_5 = 12$ A

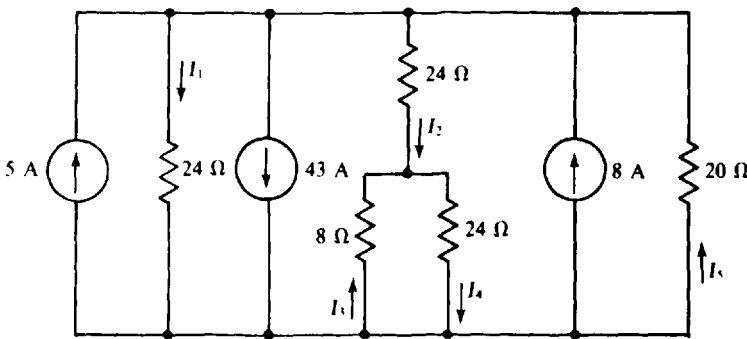

Fig. 3-35

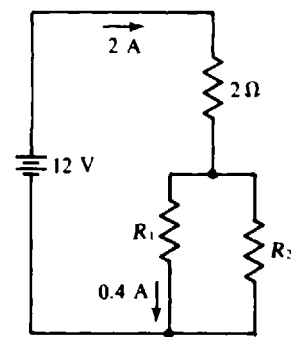

Fig. 3-36

3.81 Find R_1 and R_2 for the circuit shown in Fig. 3-36.

Ans. $R_1 = 20$ Ω , $R_2 = 5$ Ω

3.82 In the circuit shown in Fig. 3-36, let $R_1 = 6$ Ω and $R_2 = 12$ Ω . Then use current division to find the new current in the R_1 resistor.

Ans. 1.33 A

3.83 A 60-A current flows into a resistor network described by $R_T = 40 \parallel (12 + 40 \parallel 10)$. Find the current in the 10- Ω resistor.

Ans. 32 A

3.84 A 620-V source connected to a resistor network described by $R_T = 50 + R \parallel 20$ provides 120 V to the 20- Ω resistor. What is R ?

Ans. 30 Ω

3.85 Find I in the circuit shown in Fig. 3-37.

Ans. 4 A

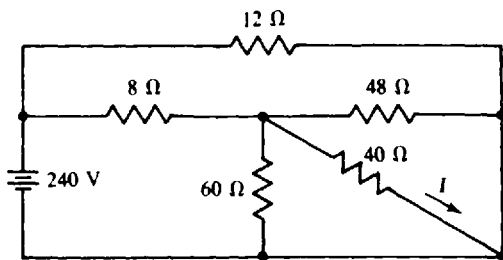

Fig. 3-37

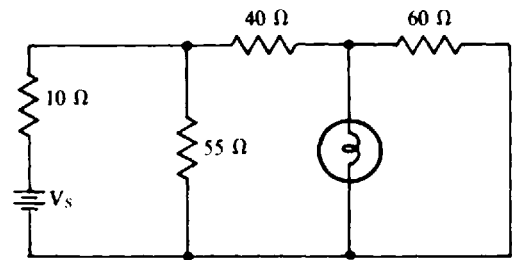

Fig. 3-38

3.86 In the circuit shown in Fig. 3-38 there is a 120-V, 60-W light bulb. What must be the supply voltage V_s for the light bulb to operate under rated conditions?

Ans. 285 V

3.87 In the circuit of Fig. 3-39, calculate I and also the power absorbed by the dependent source.

Ans. 2 A, 560 W

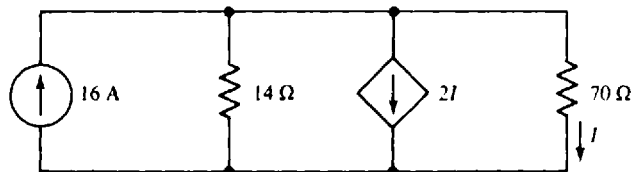

Fig. 3-39

3.88 Use voltage division twice to find the voltage V in the circuit shown in Fig. 3-40.

Ans. 36 V

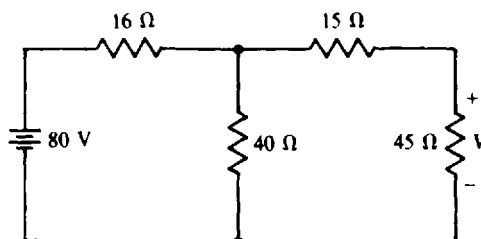

Fig. 3-40

3.89 In the circuit shown in Fig. 3-41, use current division twice to calculate the current I in the load resistor R_L for (a) $R_L = 0 \Omega$, (b) $R_L = 5 \Omega$, and (c) $R_L = 20 \Omega$.

Ans. (a) 16 A, (b) 9.96 A, (c) 4.67 A

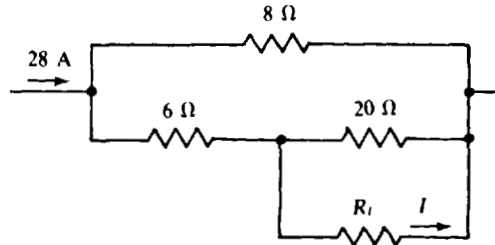

Fig. 3-41

3.90 Use repeated current division in finding I in the circuit of Fig. 3-42.

Ans. 4 mA

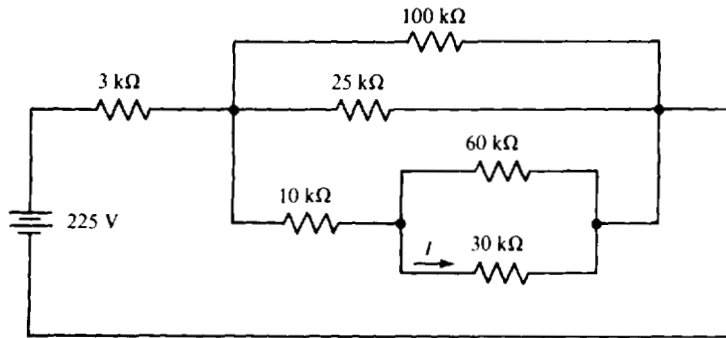

Fig. 3-42

DC Circuit Analysis

CRAMER'S RULE

A knowledge of *determinants* is necessary for using *Cramer's rule*, which is a popular method for solving the *simultaneous equations* that occur in the analysis of a circuit. A determinant is a square arrangement of numbers between two vertical lines, as follows:

$$\begin{vmatrix} a_{11} & a_{12} & a_{13} \\ a_{21} & a_{22} & a_{23} \\ a_{31} & a_{32} & a_{33} \end{vmatrix}$$

in which each a is a number. The first and second subscripts indicate the row and column, respectively, that each number is in.

A determinant with two rows and columns is a second-order determinant. One with three rows and columns is a third-order determinant, and so on.

Determinants have values. The value of the second-order determinant

$$\begin{vmatrix} a_{11} & a_{12} \\ a_{21} & a_{22} \end{vmatrix}$$

is $a_{11}a_{22} - a_{21}a_{12}$, which is the product of the numbers on the principal diagonal minus the product of the numbers on the other diagonal:

$$\begin{array}{ccc} a_{11} & & a_{12} \\ & \searrow & \nearrow \\ & a_{22} & a_{21} \end{array} -$$

For example, the value of

$$\begin{vmatrix} 8 & -2 \\ 6 & -4 \end{vmatrix}$$

is $8(-4) - 6(-2) = -32 + 12 = -20$.

A convenient method for evaluating a third-order determinant is to repeat the first two columns to the right of the third column and then take the sum of the products of the numbers on the diagonals indicated by downward arrows, as follows, and subtract from this the sum of the products of the numbers on the diagonals indicated by upward arrows. The result is

$$a_{11}a_{22}a_{33} + a_{12}a_{23}a_{31} + a_{13}a_{21}a_{32} - a_{31}a_{22}a_{13} - a_{32}a_{23}a_{11} - a_{33}a_{21}a_{12}$$

$$\begin{vmatrix} a_{11} & a_{12} & a_{13} & a_{11} & a_{12} \\ a_{21} & a_{22} & a_{23} & a_{21} & a_{22} \\ a_{31} & a_{32} & a_{33} & a_{31} & a_{32} \end{vmatrix}$$

For example, the value of

$$\begin{vmatrix} 2 & -3 & 4 \\ 6 & 10 & 8 \\ 7 & -5 & 9 \end{vmatrix}$$

from

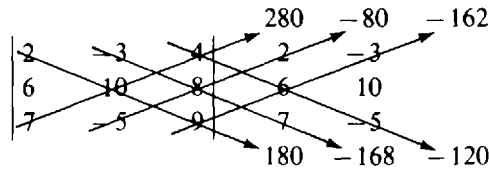

is $180 - 168 - 120 - (280 - 80 - 162) = -146$.

Evaluations of higher-order determinants require other methods that will not be considered here.

Before Cramer's rule can be applied to solve for the unknowns in a set of equations, the equations must be arranged with the unknowns on one side, say the left, of the equal signs and the knowns on the right-hand side. The unknowns should have the same order in each equation. For example, I_1 may be the first unknown in each equation, I_2 the second, and so on. Then, by Cramer's rule, each unknown is the ratio of two determinants. The denominator determinants are the same, being formed from the coefficients of the unknowns. Each numerator determinant differs from the denominator determinant in only one column. For the first unknown, the numerator determinant has a *first* column that is the right-hand side of the equations. For the second unknown, the numerator determinant has a *second* column that is the right-hand side of the equations, and so on. As an illustration, for

$$\begin{aligned} 10I_1 - 2I_2 - 4I_3 &= 32 \\ -2I_1 + 12I_2 - 9I_3 &= -43 \\ -4I_1 - 9I_2 + 15I_3 &= 13 \end{aligned}$$

$$I_1 = \frac{\begin{vmatrix} 32 & -2 & -4 \\ -43 & 12 & -9 \\ 13 & -9 & 15 \end{vmatrix}}{\begin{vmatrix} 10 & -2 & -4 \\ -2 & 12 & -9 \\ -4 & -9 & 15 \end{vmatrix}} \quad I_2 = \frac{\begin{vmatrix} 10 & 32 & -4 \\ -2 & -43 & -9 \\ -4 & 13 & 15 \end{vmatrix}}{\begin{vmatrix} 10 & -2 & -4 \\ -2 & 12 & -9 \\ -4 & -9 & 15 \end{vmatrix}} \quad I_3 = \frac{\begin{vmatrix} 10 & -2 & 32 \\ -2 & 12 & -43 \\ -4 & -9 & 13 \end{vmatrix}}{\begin{vmatrix} 10 & -2 & -4 \\ -2 & 12 & -9 \\ -4 & -9 & 15 \end{vmatrix}}$$

CALCULATOR SOLUTIONS

Although using Cramer's rule is popular, a much better way to solve the simultaneous equations of interest here is to use an advanced scientific calculator. No programming is required, the equations are easy to enter, and solutions can be obtained just by pressing a single key. Typically the equations must be first placed in *matrix form*. But no knowledge of matrix algebra is required.

To be placed in matrix form, the equations must be arranged in exactly the same form as for using Cramer's rule, with the unknowns being in the same order in each equation. Then, three matrices are formed from these equations. As an illustration, for the following previously considered equations,

$$\begin{aligned} 10I_1 - 2I_2 - 4I_3 &= 32 \\ -2I_1 + 12I_2 - 9I_3 &= -43 \\ -4I_1 - 9I_2 + 15I_3 &= 13 \end{aligned}$$

the corresponding matrix equation is

$$\begin{bmatrix} 10 & -2 & -4 \\ -2 & 12 & -9 \\ -4 & -9 & 15 \end{bmatrix} \begin{bmatrix} I_1 \\ I_2 \\ I_3 \end{bmatrix} = \begin{bmatrix} 32 \\ -43 \\ 13 \end{bmatrix}$$

Incidentally, a matrix comprising a single column is usually referred to as a *vector*.

The elements of the three-by-three matrix are just the coefficients of the unknowns and are identical to the elements in the denominator determinant of Cramer's rule. The adjacent vector has elements that

are the unknowns being solved for, and the vector on the right-hand side has elements that consist of the right-hand sides of the original equations.

The elements of the vector on the right-hand side and the elements of the coefficient matrix are then entered into a calculator. The exact method of entering the elements depends on the calculator used but should be simple to do. Typically, the solutions are returned in a vector, and they appear in the same order as the corresponding quantity symbols in the vector of unknowns.

The calculator method cannot be too strongly recommended. The decrease in errors and the time saved will quickly compensate the user for the little additional cost that was required to purchase such a calculator. The calculator should also be capable of solving simultaneous equations that have complex, instead of just real, coefficients, as will be required later for the analysis of sinusoidally excited circuits.

SOURCE TRANSFORMATIONS

Depending on the type of analysis, a circuit with either no voltage sources or no current sources may be preferable. Because a circuit may have an undesired type of source, it is convenient to be able to transform voltage sources to equivalent current sources, and current sources to equivalent voltage sources. For a transformation, each voltage source should have a *series* internal resistance, and each current source a *parallel* internal resistance.

Figure 4-1a shows the transformation from a voltage source to an equivalent current source, and Fig. 4-1b the transformation from a current source to an equivalent voltage source. This equivalence applies only to the external circuit connected to these sources. The voltages and currents of this external circuit will be the same with either source. Internally, the sources are usually *not* equivalent.

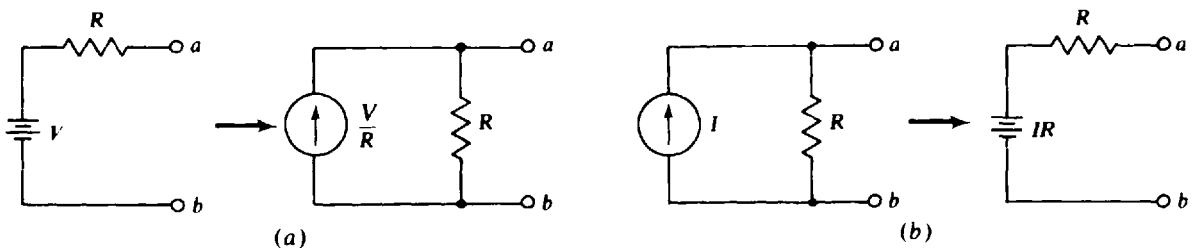

Fig. 4-1

As shown, in the transformation of a voltage source to an equivalent current source, the same resistor is in parallel with the current source, and the source current equals the original source voltage divided by the resistance of this resistor. The current source arrow is directed toward the terminal nearest the positive terminal of the voltage source. In the transformation from a current source to an equivalent voltage source, the same resistor is in series with the voltage source, and the source voltage equals the original source current times the resistance of this resistor. The positive terminal of the voltage source is nearest the terminal toward which the arrow of the current source is directed. This same procedure applies to the transformations of dependent sources.

MESH ANALYSIS

In *mesh analysis*, KVL is applied with mesh currents, which are currents assigned to meshes, and preferably referenced to flow clockwise, as shown in Fig. 4-2a.

KVL is applied to each mesh, one at a time, using the fact that in the direction of a current I , the voltage drop across a resistor is IR , as shown in Fig. 4-2b. The voltage drops across the resistors taken in the direction of the mesh currents are set equal to the voltage rises across the voltage sources. As an illustration, in the circuit shown in Fig. 4-2a, around mesh 1 the drops across resistors R_1 and R_3 are

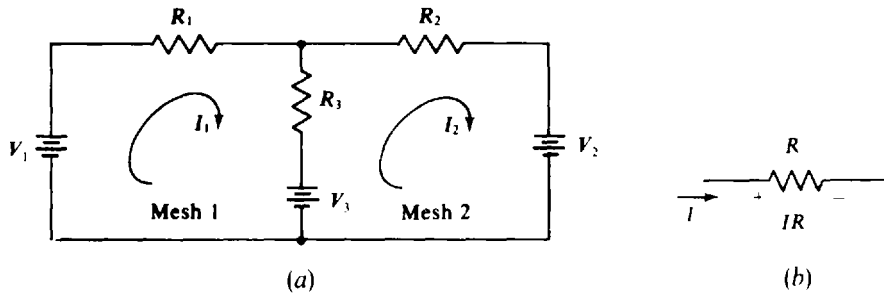

Fig. 4-2

$I_1 R_1$ and $(I_1 - I_2)R_3$, respectively, the latter because the current through R_3 in the direction of I_1 is $I_1 - I_2$. The total voltage rise from voltage sources is $V_1 - V_3$, in which V_3 has a negative sign because it is a voltage drop. So, the mesh equation for mesh 1 is

$$I_1 R_1 + (I_1 - I_2)R_3 = V_1 - V_3 \quad \text{or} \quad (R_1 + R_3)I_1 - R_3 I_2 = V_1 - V_3$$

Notice that $R_1 + R_3$, the coefficient of I_1 , is the sum of the resistances of the resistors in mesh 1. This sum is called the *self-resistance* of mesh 1. Also, $-R_3$, the coefficient of I_2 , is the negative of the resistance of the resistor that is common to or mutual to meshes 1 and 2. R_3 is called the *mutual resistance*. In mesh equations, mutual resistance terms always have negative signs because the other mesh currents always flow through the mutual resistors in directions opposite to those of the principal mesh currents.

It is easier to write mesh equations using self-resistances and mutual resistances than it is to directly apply KVL. Doing this for mesh 2 results in

$$-R_3 I_1 + (R_2 + R_3)I_2 = V_3 - V_2$$

In a mesh equation, the voltage for a voltage source has a positive sign if the voltage source aids the flow of the principal mesh current—that is, if this current flows out of the positive terminal—because this aiding is equivalent to a voltage rise. Otherwise, a source voltage has a negative sign.

For mesh analysis, the transformation of all current sources to voltage sources is usually preferable because there is no formula for the voltages across current sources. If, however, a current source is positioned at the exterior of a circuit such that only one mesh current flows through it, that current source can remain because the mesh current through it is known—it is the source current or the negative of it, depending on direction. KVL is not applied to this mesh.

The number of mesh equations equals the number of meshes minus the number of current sources, if there are any.

LOOP ANALYSIS

Loop analysis is similar to mesh analysis, the principal difference being that the current paths selected are loops that are not necessarily meshes. Also, there is no convention on the direction of loop currents; they can be clockwise or counterclockwise. As a result, mutual terms can be positive when KVL is applied to the loops.

For loop analysis, no current source need be transformed to a voltage source. But each current source should have only one loop current flowing through it so that the loop current is known. Also, then KVL is *not* applied to this loop because the current source voltage is unknown.

Obviously, the loops for the loop currents must be selected such that every component has at least one loop current flowing through it. The number of these loops equals the number of meshes if the circuit is *planar*—that is, if the circuit can be drawn on a flat surface with no wires crossing. In general, the number of loop currents required is $B - N + 1$, where B is the number of branches and N is the number of nodes.

If the current through only one component is desired, the loops should be selected such that only one loop current flows through this component. Then, only one current has to be solved for. In contrast, for mesh analysis, finding the current through an interior component requires solving for two mesh currents.

NODAL ANALYSIS

For *nodal analysis*, preferably all voltage sources are transformed to current sources and all resistances are converted to conductances. KCL is applied to all nodes but the ground node, which is often indicated by a ground symbol at the bottom node of the circuit, as shown in Fig. 4-3a. As mentioned in Chap. 3, almost always the bottom node is selected as the ground node even though any node can be. Conventionally, *voltages on all other nodes are referenced positive with respect to the ground node*. As a consequence, showing node voltage polarity signs is not necessary.

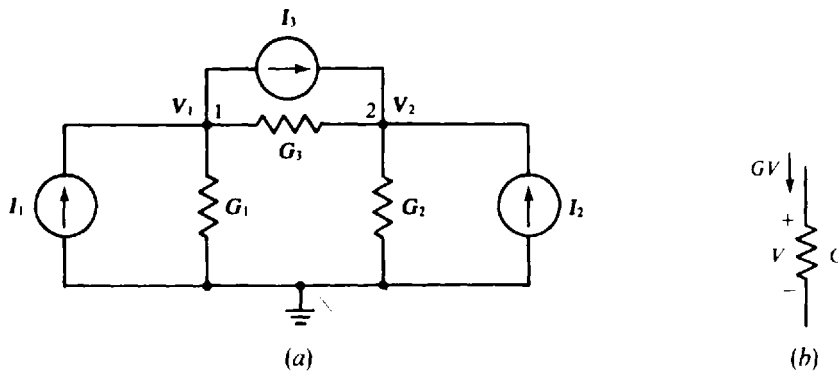

Fig. 4-3

In nodal analysis, KCL is applied to each nongrounded node, one at a time, using the fact that in the direction of a voltage drop V , the current in a resistor is GV , as shown in Fig. 4-3b. The currents leaving a node through resistors are set equal to the currents entering the node from current sources. As an illustration, in the circuit shown in Fig. 4-3a, the current flowing down through the resistor with conductance G_1 is G_1V_1 . The current to the right through the resistor with conductance G_3 is $G_3(V_1 - V_2)$. *This current is equal to the conductance times the voltage at the node at which the current enters the resistor minus the voltage at the node at which the current leaves the resistor.* The quantity $(V_1 - V_2)$ is, of course, just the resistor voltage referenced positive at the node at which the current enters the resistor and negative at the node at which the current leaves the resistor, as is required for associated references. The current entering node 1 from current sources is $I_1 - I_3$, in which I_3 has a negative sign because it is actually leaving node 1. So, the nodal equation for node 1 is

$$G_1V_1 + G_3(V_1 - V_2) = I_1 - I_3 \quad \text{or} \quad (G_1 + G_3)V_1 - G_3V_2 = I_1 - I_3$$

Notice that the V_1 coefficient of $G_1 + G_3$ is the sum of the conductances of the resistors connected to node 1. This sum is called the *self-conductance* of node 1. The coefficient of V_2 is $-G_3$, the negative of the conductance of the resistor connected between nodes 1 and 2. G_3 is called the *mutual conductance* of nodes 1 and 2. Mutual conductance terms always have negative signs because all nongrounded node voltages have the same reference polarity—all are positive.

It is easier to write nodal equations using self-conductances and mutual conductances than it is to directly apply KCL. Doing this for node 2 results in

$$-G_3V_1 + (G_2 + G_3)V_2 = I_2 + I_3$$

The transformation of all voltage sources to current sources is not absolutely essential for nodal

analysis, but is usually preferable for the shortcut approach with self-conductances and mutual conductances. The problem with voltage sources is that there is no formula for the currents flowing through them. Nodal analysis, though, is fairly easy to use with circuits having grounded voltage sources, each of which has a terminal connected to ground. Such voltage sources give known voltages at their nongrounded terminal nodes, making it unnecessary to apply KCL at these nodes. Other voltage sources—floating voltage sources—can be transformed to current sources.

The number of nodal equations equals the number of nongrounded nodes minus the number of grounded voltage sources.

DEPENDENT SOURCES AND CIRCUIT ANALYSIS

Mesh, loop, and nodal analyses are about the same for circuits having dependent sources as for circuits having only independent sources. Usually, though, there are a few more equations. Also, positive terms may appear in the circuit equations where only negative mutual resistance or conductance terms appear for circuits having no dependent sources. Almost always, a good first step in the analysis of a circuit containing dependent sources is to solve for the dependent source controlling quantities in terms of the mesh or loop currents or node voltages being solved for.

Solved Problems

4.1 Evaluate the following determinants:

$$(a) \begin{vmatrix} 1 & -2 \\ 3 & 4 \end{vmatrix} \quad (b) \begin{vmatrix} -5 & 6 \\ 7 & -8 \end{vmatrix}$$

(a) The product of the numbers on the principal diagonal is $1 \times 4 = 4$, and for the numbers on the other diagonal is $-2 \times 3 = -6$. The value of the determinant is the first product minus the second product: $4 - (-6) = 10$.

(b) Similarly, the value of the second determinant is $-5(-8) - 7(6) = 40 - 42 = -2$.

4.2 Evaluate the following determinant:

$$\begin{vmatrix} 8 & -9 & 4 \\ 3 & -2 & 1 \\ 6 & 5 & -4 \end{vmatrix}$$

One method of evaluation is to repeat the first two columns to the right of the third column and then find the products of the numbers on the diagonals, as indicated:

$$\begin{array}{ccccccc} & & & -48 & 40 & 108 & \\ \left[\begin{array}{ccc} 8 & -9 & 4 \\ 3 & -2 & 1 \\ 6 & 5 & -4 \end{array} \right. & & & \begin{array}{ccc} 8 & -9 & 4 \\ 3 & -2 & 1 \\ 6 & 5 & -4 \end{array} & & & \\ & & & 64 & -54 & 60 & \end{array}$$

The value of the determinant is the sum of the products for the downward-pointing arrows minus the sum of the products for the upward-pointing arrows:

$$(64 - 54 + 60) - (-48 + 40 + 108) = -30$$

4.3 Use Cramer's rule to solve for the unknowns in

$$\begin{aligned} 5V_1 + 4V_2 &= 31 \\ -4V_1 + 8V_2 &= 20 \end{aligned}$$

The first unknown V_1 equals the ratio of two determinants. The denominator determinant has elements that are the coefficients of V_1 and V_2 . The numerator determinant differs only in having the first column replaced by the right-hand sides of the equations:

$$V_1 = \frac{\begin{vmatrix} 31 & 4 \\ 20 & 8 \\ 5 & 4 \\ -4 & 8 \end{vmatrix}}{\begin{vmatrix} 5 & 4 \\ -4 & 8 \end{vmatrix}} = \frac{31(8) - 20(4)}{5(8) - (-4)(4)} = \frac{168}{56} = 3 \text{ V}$$

The denominator determinant for V_2 has the same value of 56. In the numerator determinant the second column, instead of the first, is replaced by the right-hand sides of the equations:

$$V_2 = \frac{\begin{vmatrix} 5 & 31 \\ -4 & 20 \end{vmatrix}}{56} = \frac{5(20) - (-4)(31)}{56} = \frac{224}{56} = 4 \text{ V}$$

4.4 Use Cramer's rule to solve for the unknowns in

$$\begin{aligned} 10I_1 - 2I_2 - 4I_3 &= 10 \\ -2I_1 + 12I_2 - 6I_3 &= -34 \\ -4I_1 - 6I_2 + 14I_3 &= 40 \end{aligned}$$

All three unknowns have the same denominator determinant of coefficients, which evaluates to

$$\begin{vmatrix} 10 & -2 & -4 \\ -2 & 12 & -6 \\ -4 & -6 & 14 \end{vmatrix} = \begin{matrix} 192 & 360 & 56 \\ -2 & 12 & -6 \\ -4 & -6 & 14 \\ 1680 & -48 & -48 \end{matrix}$$

$$1680 - 48 - 48 - (192 + 360 + 56) = 976$$

In the numerator determinants, the right-hand sides of the equations replace the first column for I_1 , the second column for I_2 , and the third column for I_3 :

$$I_1 = \frac{\begin{vmatrix} 10 & -2 & -4 \\ -34 & 12 & -6 \\ 40 & -6 & 14 \end{vmatrix}}{976} = \frac{1952}{976} = 2 \text{ A}$$

$$I_2 = \frac{\begin{vmatrix} 10 & 10 & -4 \\ -2 & -34 & -6 \\ -4 & 40 & 14 \end{vmatrix}}{976} = \frac{-976}{976} = -1 \text{ A}$$

$$I_3 = \frac{\begin{vmatrix} 10 & -2 & 10 \\ -2 & 12 & -34 \\ -4 & -6 & 40 \end{vmatrix}}{976} = \frac{2928}{976} = 3 \text{ A}$$

4.5 Transform the voltage sources shown in Fig. 4-4 to current sources.

- (a) The current of the equivalent current source equals the voltage of the original voltage source divided by the resistance: $21/3 = 7 \text{ A}$. The current direction is toward node a because the positive terminal of the voltage source is toward that node. The parallel resistor is the same $3\text{-}\Omega$ resistor of the original voltage source. The equivalent current source is shown in Fig. 4-5a.

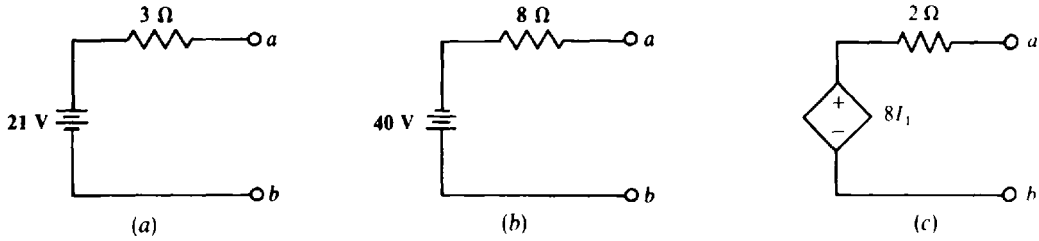

Fig. 4-4

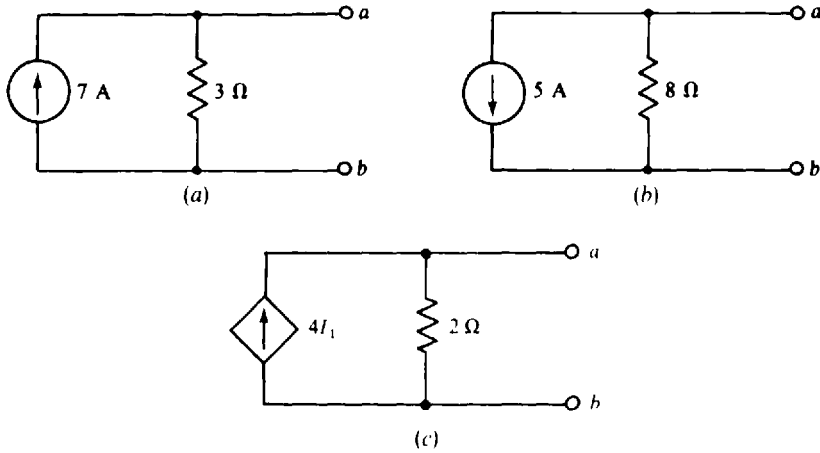

Fig. 4-5

- (b) The current of the current source is $40/8 = 5$ A. It is directed toward node *b* because the positive terminal of the voltage source is toward that node. The parallel resistor is the same 8-Ω resistor of the voltage source. Figure 4-5*b* shows the equivalent current source.
- (c) The current of the current source is $8I_1/2 = 4I_1$, with a direction toward node *a* because the positive terminal of the voltage source is toward that node. The parallel resistor is the same 2-Ω resistor of the voltage source. Figure 4-5*c* shows the equivalent current source.

4.6 Transform the current sources shown in Fig. 4-6 to voltage sources.

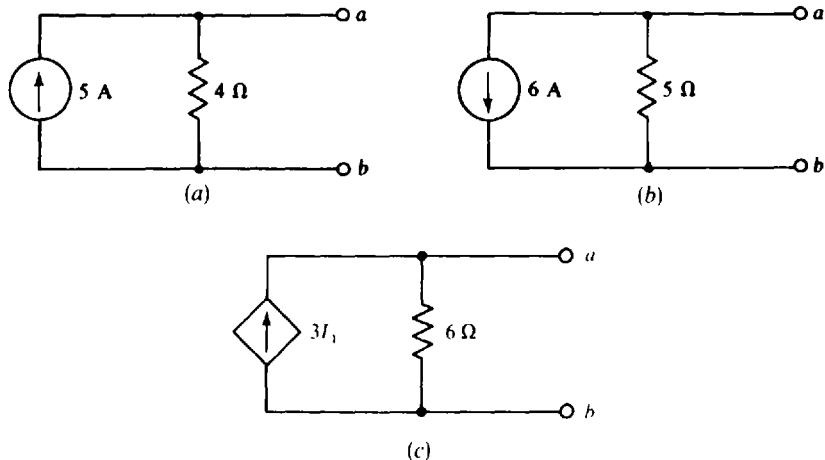

Fig. 4-6

- (a) The voltage of the equivalent voltage source equals the current of the original current source times the resistance: $5 \times 4 = 20$ V. The positive terminal is toward node a because the direction of the current of the original current source is toward that node. Of course, the source resistance remains 4Ω , but is in series instead of in parallel. Figure 4-7a shows the equivalent voltage source.
- (b) The voltage is $6 \times 5 = 30$ V, positive toward node b because the direction of the current of the original current source is toward that node. The source resistance is the same 5Ω , but is in series. The equivalent voltage source is shown in Fig. 4-7b.
- (c) The voltage is $3I_1 \times 6 = 18I_1$, positive toward node a because the direction of the current of the current source is toward that node. The source resistance is the same 6Ω but is in series. The equivalent voltage source is shown in Fig. 4-7c.

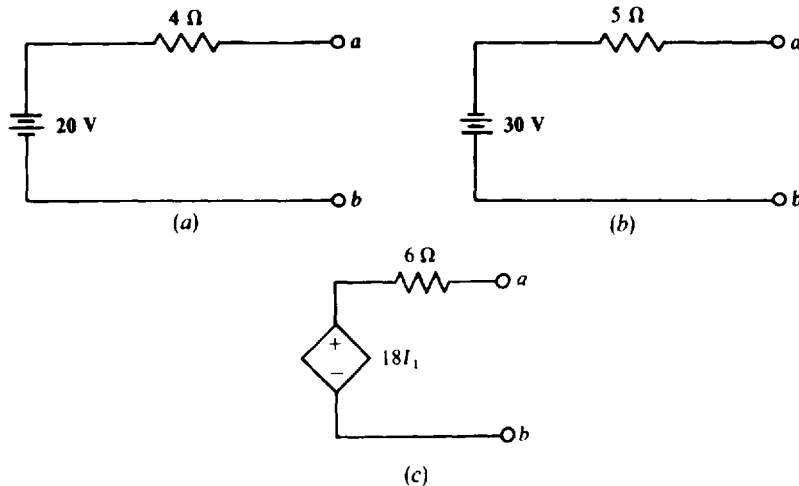

Fig. 4-7

- 4.7 Find the currents down through the resistors in the circuit shown in Fig. 4-8. Then transform the current source and $2\text{-}\Omega$ resistor to an equivalent voltage source and again find the resistor currents. Compare results.

By current division, the current down through the $2\text{-}\Omega$ resistor is

$$\frac{6}{2 + 6} \times 16 = 12 \text{ A}$$

The remainder of the source current ($16 - 12 = 4$ A) flows down through the $6\text{-}\Omega$ resistor.

Transformation of the current source produces a voltage source of $16 \times 2 = 32$ V in series with a $2\text{-}\Omega$ resistor, all in series with the $6\text{-}\Omega$ resistor, as shown in the circuit of Fig. 4-9. In this circuit, the same current $32/(2 + 6) = 4$ A flows through both resistors. The $6\text{-}\Omega$ resistor current is the same as for the original circuit, but the $2\text{-}\Omega$ resistor current is different. This result illustrates the fact that although a transformed source produces the same voltages and currents in the circuit exterior to the source, the voltages and currents inside the source usually change.

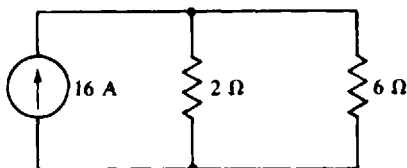

Fig. 4-8

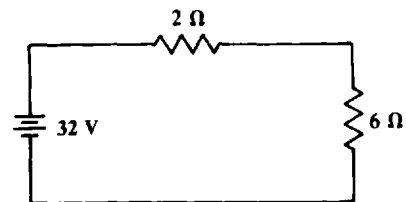

Fig. 4-9

- 4.8 For the circuit of Fig. 4-10, use repeated source transformations to obtain a single mesh circuit, and then find the current I .

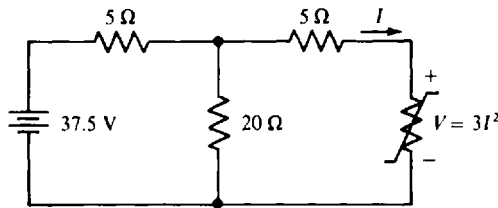

Fig. 4-10

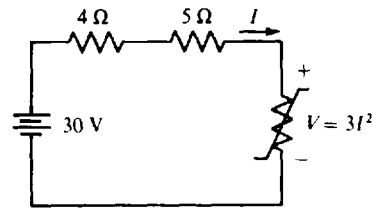

Fig. 4-11

The first step is to transform the voltage source and series resistor into a current source and parallel resistor. The resistance does not change, but the source current is $37.5/5 = 7.5$ A directed upward. The 5-Ω resistor from the source transformation is in parallel with the 20-Ω resistor. Consequently, the combined resistance is $(5 \times 20)/(5 + 20) = 4$ Ω. The next step is to transform the 7.5-A current source and the parallel 4-Ω resistor into a series voltage source and resistor. The resistance remains the same, and the voltage of the voltage source is $4(7.5) = 30$ V, positive upward, as shown in the circuit of Fig. 4-11, which is a single mesh circuit.

The KVL equation for this circuit is $3I^2 + 9I - 30 = 0$, from which the current I can be obtained by applying the quadratic formula:

$$I = \frac{-9 \pm \sqrt{9^2 - 4(3)(-30)}}{2(3)}$$

The solutions are $I = 2$ A and $I = -5$ A. Only the $I = 2$ A is physically possible. The current must be positive since in the circuit of Fig. 4-11 there is only one source, and current must flow out of the positive terminal of this source.

- 4.9 Find the mesh currents in the circuit shown in Fig. 4-12.

The self-resistance of mesh 1 is $5 + 6 = 11$ Ω, and the resistance mutual with mesh 2 is 6 Ω. The sum of the source voltage rises in the direction of I_1 is $62 - 16 = 46$ V. So, the mesh 1 KVL equation is $11I_1 - 6I_2 = 46$.

No KVL equation is needed for mesh 2 because I_2 is the only current flowing through the 4-A current source, with the result that $I_2 = -4$ A. The current I_2 is negative because its reference direction is down through the current source, but the 4-A source current actually flows up. Incidentally, a KVL equation cannot be written for mesh 2 without introducing a variable for the voltage across the current source because this voltage is unknown.

The substitution of $I_2 = -4$ A into the mesh 1 equation results in

$$11I_1 - 6(-4) = 46 \quad \text{and} \quad I_1 = \frac{22}{11} = 2 \text{ A}$$

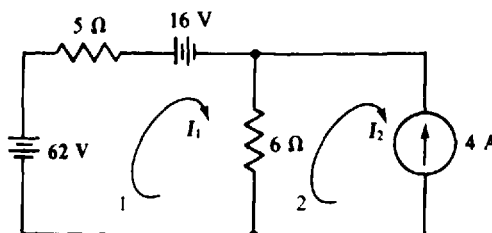

Fig. 4-12

4.10 Determine the mesh currents in the circuit shown in Fig. 4-13.

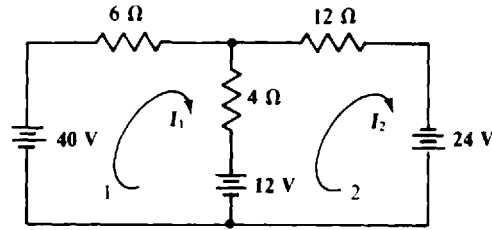

Fig. 4-13

The self-resistance of mesh 1 is $6 + 4 = 10 \Omega$, the mutual resistance with mesh 2 is 4Ω , and the sum of the source voltage rises in the direction of I_1 is $40 - 12 = 28 \text{ V}$. So, the mesh 1 KVL equation is $10I_1 - 4I_2 = 28$.

Similarly, for mesh 2 the self-resistance is $4 + 12 = 16 \Omega$, the mutual resistance is 4Ω , and the sum of the voltage rises from voltage sources is $24 + 12 = 36 \text{ V}$. These give a mesh 2 KVL equation of $-4I_1 + 16I_2 = 36$.

Placing the two mesh equations together shows the symmetry of coefficients (here -4) about the principal diagonal as a result of the common mutual resistance:

$$10I_1 - 4I_2 = 28$$

$$-4I_1 + 16I_2 = 36$$

A good way to solve these two equations is to add four times the first equation to the second equation to eliminate I_2 . The result is

$$40I_1 - 4I_1 = 112 + 36 \quad \text{from which} \quad I_1 = \frac{148}{36} = 4.11 \text{ A}$$

This substituted into the second equation gives

$$-4(4.11) + 16I_2 = 36 \quad \text{and} \quad I_2 = \frac{52.44}{16} = 3.28 \text{ A}$$

4.11 Obtain the mesh currents in the circuit of Fig. 4-14.

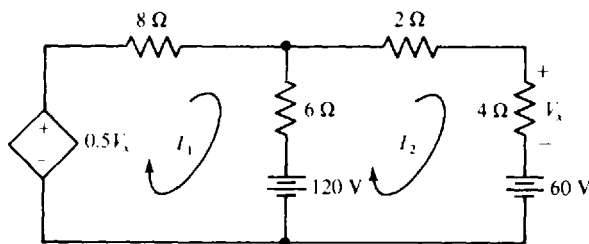

Fig. 4-14

A good first step is to solve for the controlling quantity V_x in terms of the mesh current I_2 . Clearly, $V_x = 4I_2$, and consequently the voltage of the dependent source is $0.5V_x = 0.5(4I_2) = 2I_2$. Then, the application of KVL to the meshes gives

$$(8 + 6)I_1 - 6I_2 - 2I_2 = -120$$

and

$$(6 + 2 + 4)I_2 - 6I_1 = 120 - 60$$

In matrix form, these simplify to

$$\begin{bmatrix} 14 & -8 \\ -6 & 12 \end{bmatrix} \begin{bmatrix} I_1 \\ I_2 \end{bmatrix} = \begin{bmatrix} -120 \\ 60 \end{bmatrix}$$

In the matrix of coefficients, the lack of symmetry about the principal diagonal is the result of the action of the dependent source. The solutions can be obtained by using Cramer's rule or, preferably, by using a calculator. The mesh currents are $I_1 = -8 \text{ A}$ and $I_2 = 1 \text{ A}$.

4.12 Find the mesh currents in the circuit shown in Fig. 4-15.

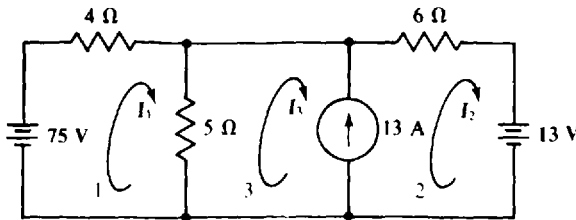

Fig. 4-15

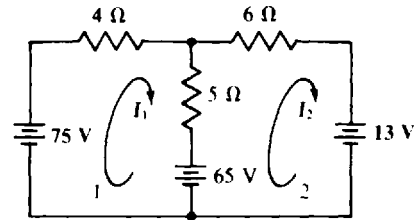

Fig. 4-16

One analysis approach is to transform the 13-A current source and parallel 5-Ω resistor into a voltage source, as shown in the circuit of Fig. 4-16.

The self-resistance of mesh 1 is $4 + 5 = 9 \Omega$, and that of mesh 2 is $6 + 5 = 11 \Omega$. The mutual resistance is 5Ω . The voltage rises from sources are $75 - 65 = 10 \text{ V}$ for mesh 1 and $65 - 13 = 52 \text{ V}$ for mesh 2. The corresponding mesh equations are

$$\begin{aligned} 9I_1 - 5I_2 &= 10 \\ -5I_1 + 11I_2 &= 52 \end{aligned}$$

Multiplying the first equation by 5 and the second by 9 and then adding them eliminates I_1 :

$$-25I_2 + 99I_2 = 50 + 468 \quad \text{from which} \quad I_2 = \frac{518}{74} = 7 \text{ A}$$

This substituted into the first equation produces

$$9I_1 - 5(7) = 10 \quad \text{or} \quad I_1 = \frac{10 + 35}{9} = 5 \text{ A}$$

From the original circuit shown in Fig. 4-15, the current through the current source is $I_2 - I_3 = 13 \text{ A}$, and so

$$I_3 = I_2 - 13 = 7 - 13 = -6 \text{ A}$$

Another approach is to use the so-called *supermesh method*, which is applicable when a circuit contains internal current sources. Mesh currents are used, but for each internal current source, KVL is applied to the loop that would be a mesh if the current source were removed. For the circuit of Fig. 4-15, this loop (supermesh) comprises the 5-Ω and 6-Ω resistors and the 13-V source. The KVL equation is $5(I_3 - I_1) + 6I_2 = -13$. This, with the mesh 1 equation of $9I_1 - 5I_3 = 75$, comprises two equations with three unknowns. The required third equation can be obtained by applying KCL to either node of the current source, or, more simply, by noting that the current up through the current source in terms of mesh currents is $I_2 - I_3$. This current must, of course, be equal to the 13 A of the source. So, the two KVL equations are augmented with the single KCL equation $I_2 - I_3 = 13$. In matrix form these equations are

$$\begin{bmatrix} -5 & 6 & 5 \\ 9 & 0 & -5 \\ 0 & 1 & -1 \end{bmatrix} \begin{bmatrix} I_1 \\ I_2 \\ I_3 \end{bmatrix} = \begin{bmatrix} -13 \\ 75 \\ 13 \end{bmatrix}$$

The solutions are the same as obtained before: $I_1 = 5 \text{ A}$, $I_2 = 7 \text{ A}$, and $I_3 = -6 \text{ A}$.

In general, for the supermesh approach, the KVL equations must be augmented with KCL equations, the number of which is equal to the number of internal current sources.

4.13 Find the mesh currents in the circuit shown in Fig. 4-17.

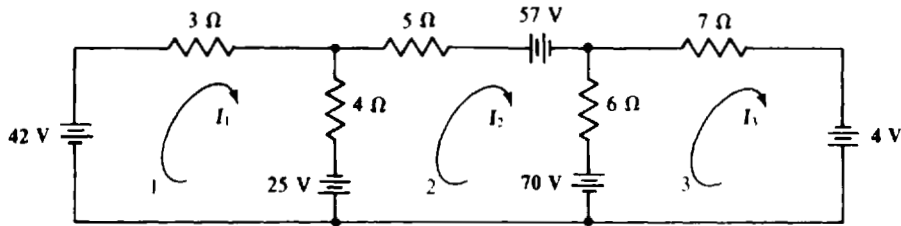

Fig. 4-17

The self-resistances are $3 + 4 = 7\ \Omega$ for mesh 1, $4 + 5 + 6 = 15\ \Omega$ for mesh 2, and $6 + 7 = 13\ \Omega$ for mesh 3. The mutual resistances are $4\ \Omega$ for meshes 1 and 2, $6\ \Omega$ for meshes 2 and 3, and $0\ \Omega$ for meshes 1 and 3. The aiding source voltages are $42 + 25 = 67\ \text{V}$ for mesh 1, $-25 - 57 - 70 = -152\ \text{V}$ for mesh 2, and $70 + 4 = 74\ \text{V}$ for mesh 3. So, the mesh equations are

$$\begin{array}{r} 7I_1 - 4I_2 - 0I_3 = 67 \\ -4I_1 + 15I_2 - 6I_3 = -152 \\ -0I_1 - 6I_2 + 13I_3 = 74 \end{array}$$

Notice the indicated symmetry of the mutual coefficients about the principal diagonal, shown as a dashed line. Because of the common mutual resistances, this symmetry always occurs — unless a circuit has dependent sources. Also, notice for each mesh that the self-resistance is equal to or greater than the sum of the mutual resistances because the self-resistance includes the mutual resistances.

By Cramer's rule,

$$I_1 = \frac{\begin{vmatrix} 67 & -4 & 0 \\ -152 & 15 & -6 \\ 74 & -6 & 13 \end{vmatrix}}{\begin{vmatrix} 7 & -4 & 0 \\ -4 & 15 & -6 \\ 0 & -6 & 13 \end{vmatrix}} = \frac{4525}{905} = 5\ \text{A}$$

$$I_2 = \frac{\begin{vmatrix} 7 & 67 & 0 \\ -4 & -152 & -6 \\ 0 & 74 & 13 \end{vmatrix}}{\begin{vmatrix} 7 & -4 & 0 \\ -4 & 15 & -6 \\ 0 & -6 & 13 \end{vmatrix}} = \frac{-7240}{905} = -8\ \text{A}$$

$$I_3 = \frac{\begin{vmatrix} 7 & -4 & 67 \\ -4 & 15 & -152 \\ 0 & -6 & 74 \end{vmatrix}}{\begin{vmatrix} 7 & -4 & 0 \\ -4 & 15 & -6 \\ 0 & -6 & 13 \end{vmatrix}} = \frac{1810}{905} = 2\ \text{A}$$

4.14 Find the mesh currents in the circuit shown in Fig. 4-18.

The self-resistances are $3 + 4 + 5 = 12\ \Omega$ for mesh 1, $5 + 6 + 7 = 18\ \Omega$ for mesh 2, and $6 + 4 + 8 = 18\ \Omega$ for mesh 3. The mutual resistances are $5\ \Omega$ for meshes 1 and 2, $6\ \Omega$ for meshes 2 and 3, and $4\ \Omega$ for meshes 1 and 3. The aiding source voltages are $150 - 100 - 74 = -24\ \text{V}$ for mesh 1, $74 + 15 + 23 = 112\ \text{V}$ for mesh 2, and $100 - 191 - 15 = -106\ \text{V}$ for mesh 3. So, the mesh equations are

$$\begin{array}{r} 12I_1 - 5I_2 - 4I_3 = -24 \\ -5I_1 + 18I_2 - 6I_3 = 112 \\ -4I_1 - 6I_2 + 18I_3 = -106 \end{array}$$

For a check, notice the symmetry of the coefficients about the principal diagonal.

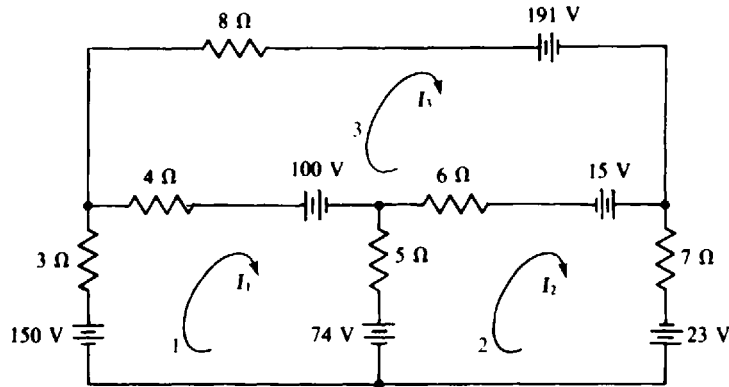

Fig. 4-18

By Cramer's rule,

$$I_1 = \frac{\begin{vmatrix} -24 & -5 & -4 \\ 112 & 18 & -6 \\ -106 & -6 & 18 \end{vmatrix}}{\begin{vmatrix} 12 & -5 & -4 \\ -5 & 18 & -6 \\ -4 & -6 & 18 \end{vmatrix}} = \frac{-4956}{2478} = -2 \text{ A}$$

$$I_2 = \frac{\begin{vmatrix} 12 & -24 & -4 \\ -5 & 112 & -6 \\ -4 & -106 & 18 \end{vmatrix}}{\begin{vmatrix} 12 & -5 & -4 \\ -5 & 18 & -6 \\ -4 & -6 & 18 \end{vmatrix}} = \frac{9912}{2478} = 4 \text{ A}$$

$$I_3 = \frac{\begin{vmatrix} 12 & -5 & -24 \\ -5 & 18 & 112 \\ -4 & -6 & -106 \end{vmatrix}}{\begin{vmatrix} 12 & -5 & -4 \\ -5 & 18 & -6 \\ -4 & -6 & 18 \end{vmatrix}} = \frac{-12390}{2478} = -5 \text{ A}$$

4.15 Use mesh analysis in determining the power absorbed by the dependent voltage source in the circuit of Fig. 4-19.

In terms of mesh currents, the dependent source controlling quantity I_x is $I_x = I_1 - I_2$. So, the dependent source provides a voltage of $20I_x = 20(I_1 - I_2)$. In writing mesh equations for a circuit that has dependent sources, a good approach is to temporarily ignore the dependent sources, write the mesh

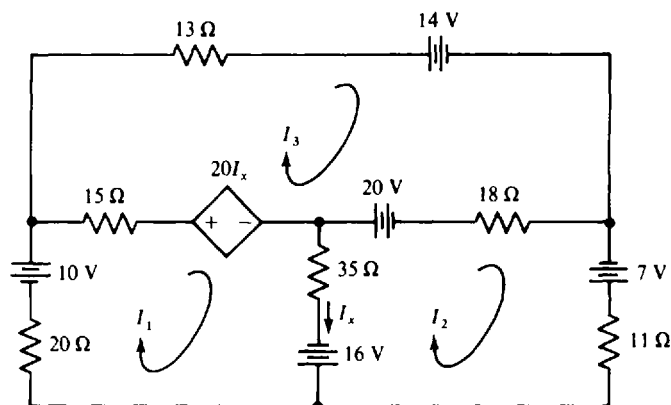

Fig. 4-19

equations using the self- and mutual-resistance approach, and then add the dependent source expressions to the pertinent equations. The result of doing that here is

$$\begin{aligned} 70I_1 - 35I_2 - 15I_3 + 20(I_1 - I_2) &= 10 + 16 \\ -35I_1 + 64I_2 - 18I_3 &= 7 - 16 - 20 \\ -15I_1 - 18I_2 + 46I_3 - 20(I_1 - I_2) &= 20 - 14 \end{aligned}$$

which simplify to

$$\begin{bmatrix} 90 & -55 & -15 \\ -35 & 64 & -18 \\ -35 & 2 & 46 \end{bmatrix} \begin{bmatrix} I_1 \\ I_2 \\ I_3 \end{bmatrix} = \begin{bmatrix} 26 \\ -29 \\ 6 \end{bmatrix}$$

The solutions are $I_1 = 0.148$ A, $I_2 = -0.3$ A, and $I_3 = 0.256$ A. Finally, the power absorbed by the dependent source is equal to the source voltage times the current flow into the positive-referenced terminal:

$$P = 20(I_1 - I_2)(I_1 - I_3) = 20(0.148 + 0.3)(0.148 - 0.256) = -0.968 \text{ W}$$

4.16 Use mesh analysis in finding V_0 in the circuit of Fig. 4.20.

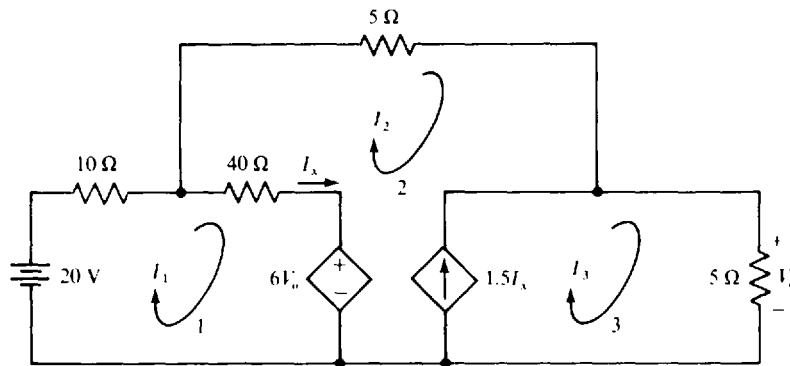

Fig. 4-20

As always for a circuit containing dependent sources, a good first step is to solve for the dependent source controlling quantities in terms of the quantities being solved for, which are mesh currents here. Obviously, $I_x = I_1 - I_2$ and $V_0 = 5I_3$. So, the dependent current source provides a current of $1.5I_x = 1.5(I_1 - I_2)$ and the dependent voltage source provides a voltage of $6V_0 = 6(5I_3) = 30I_3$.

The KVL equation for mesh 1 is $(10 + 40)I_1 - 40I_2 + 30I_3 = 20$. Preferably, KVL should not be applied to meshes 2 and 3 because of the dependent current source that is in these meshes. But a good approach to use is the supermesh method presented in Prob. 4.12. Applying KVL to the mesh obtained by deleting this current source gives the equation $-30I_3 + 40(I_2 - I_1) + 5I_2 + 5I_3 = 0$. The necessary third independent equation, $1.5(I_1 - I_2) = I_3 - I_2$, is obtained by applying KCL at a terminal of the dependent current source. These three equations simplify to, in matrix form,

$$\begin{bmatrix} 50 & -40 & 30 \\ -40 & 45 & -25 \\ 1.5 & -0.5 & -1 \end{bmatrix} \begin{bmatrix} I_1 \\ I_2 \\ I_3 \end{bmatrix} = \begin{bmatrix} 20 \\ 0 \\ 0 \end{bmatrix}$$

Then Cramer's rule or, preferably, a calculator can be used to obtain the current $I_3 = 0.792$ A. Finally, $V_0 = 5I_3 = 5(0.792) = 3.96$ V.

4.17 Use loop analysis to find the current flowing to the right through the 5-kΩ resistor in the circuit shown in Fig. 4-21.

Three loop currents are required because the circuit has three meshes. Only one loop current should flow through the 5-kΩ resistor so that only one current needs to be solved for. The paths for the two other loop currents can be selected as shown, but there are other suitable paths.

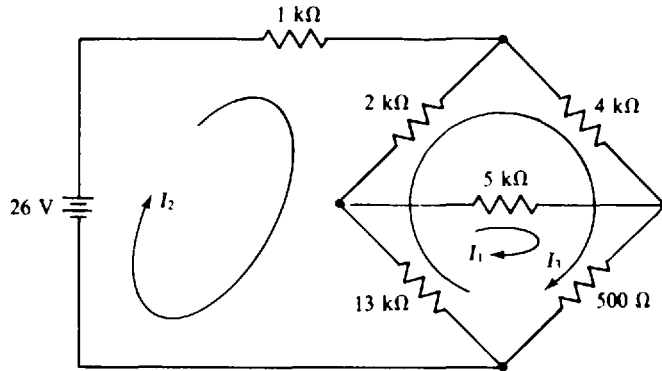

Fig. 4-21

As has been mentioned, since working with kilohms is inconvenient, a common practice is to drop those units— to divide each resistance by 1000. But then the current answers will be in milliamperes. With this approach, and from self-resistances, mutual resistances, and aiding source voltages, the loop equations are

$$\begin{aligned} 18.5I_1 - 13I_2 + 13.5I_3 &= 0 \\ -13I_1 + 16I_2 - 15I_3 &= 26 \\ 13.5I_1 - 15I_2 + 19.5I_3 &= 0 \end{aligned}$$

Notice the symmetry of the I coefficients about the principal diagonal, just as for mesh equations. But there is the difference that some of these coefficients are positive. This is the result of two loop currents flowing through a mutual resistor in the same direction— something that cannot happen in mesh analysis if all mesh currents are selected in the clockwise direction, as is conventional.

From Cramer's rule,

$$I_1 = \frac{\begin{vmatrix} 0 & -13 & 13.5 \\ 26 & 16 & -15 \\ 0 & -15 & 19.5 \end{vmatrix}}{\begin{vmatrix} 18.5 & -13 & 13.5 \\ -13 & 16 & -15 \\ 13.5 & -15 & 19.5 \end{vmatrix}} = \frac{1326}{663} = 2 \text{ mA}$$

- 4.18** Use loop analysis to find the current down through the 8-Ω resistor in the circuit shown in Fig. 4-22.

Because the circuit has three meshes, the analysis requires three loop currents. The loops can be selected as shown, with only one current I_1 flowing through the 8-Ω resistor so that only one current needs to be

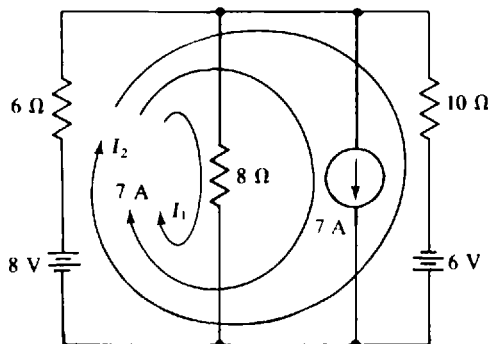

Fig. 4-22

solved for. Also, only one loop current should flow through the 7-A source so that this loop current is known, making it unnecessary to apply KVL to the corresponding loop. There are other ways of selecting the loop current paths to satisfy these conditions.

The self-resistance of the first loop is $6 + 8 = 14 \Omega$, and the resistance mutual with the second loop is 6Ω . The 7-A current flowing through the $6\text{-}\Omega$ resistor produces a 42-V drop in the first loop. The resulting loop equation is

$$14I_1 + 6I_2 + 42 = 8 \quad \text{or} \quad 14I_1 + 6I_2 = -34$$

The 6 coefficient of I_2 is positive because I_2 flows through the $6\text{-}\Omega$ resistor in the same direction as I_1 .

For the second loop, the self-resistance is $6 + 10 = 16 \Omega$, of which 6Ω is mutual with the first loop. The second loop equation is

$$6I_1 + 16I_2 + 42 = 8 + 6 \quad \text{or} \quad 6I_1 + 16I_2 = -28$$

The two loop equations together are

$$14I_1 + 6I_2 = -34$$

$$6I_1 + 16I_2 = -28$$

Multiplying the first equation by 8 and the second by -3 and then adding them eliminates I_2 :

$$112I_1 - 18I_1 = -272 + 84 \quad \text{from which} \quad I_1 = -\frac{188}{94} = -2 \text{ A}$$

- 4.19** Two 12-V batteries are being charged from a 16-V generator. The internal resistances are 0.5 and 0.8Ω for the batteries and 2Ω for the generator. Find the currents flowing into the positive battery terminals.

The arrangement is basically parallel, with just two nodes. If the voltage at the positive node with respect to the negative node is called V , the current flowing away from the positive node through the sources is

$$\frac{V - 12}{0.5} + \frac{V - 12}{0.8} + \frac{V - 16}{2} = 0$$

Multiplying by 4 produces

$$8V - 96 + 5V - 60 + 2V - 32 = 0 \quad \text{or} \quad 15V = 188 \quad \text{and} \quad V = \frac{188}{15} = 12.533 \text{ V}$$

Consequently, the current into the 12-V battery with $0.5\text{-}\Omega$ internal resistance is $(12.533 - 12)/0.5 = 1.07$ A, and the current into the other 12-V battery is $(12.533 - 12)/0.8 = 0.667$ A.

- 4.20** Determine the node voltages in the circuit shown in Fig. 4-23,

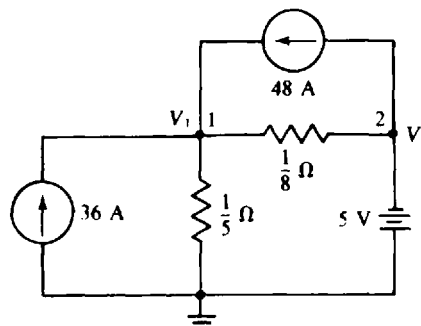

Fig. 4-23

Using self-conductances and mutual conductances is almost always best for getting the nodal equations. The self-conductance of node 1 is $5 + 8 = 13 \text{ S}$, and the mutual conductance is 8 S . The sum of the currents from current sources into this node is $36 + 48 = 84 \text{ A}$. So, the node 1 KCL equation is $13V_1 - 8V_2 = 84$.

No KCL equation is needed for node 2 because a grounded voltage source is connected to it, making $V_2 = -5 \text{ V}$. Anyway, a KCL equation cannot be written for this node without introducing a variable for the current through the 5-V source because this current is unknown.

The substitution of $V_2 = -5 \text{ V}$ into the node 1 equation results in

$$13V_1 - 8(-5) = 84 \quad \text{and} \quad V_1 = \frac{44}{13} = 3.38 \text{ V}$$

4.21 Find the node voltages in the circuit shown in Fig. 4-24.

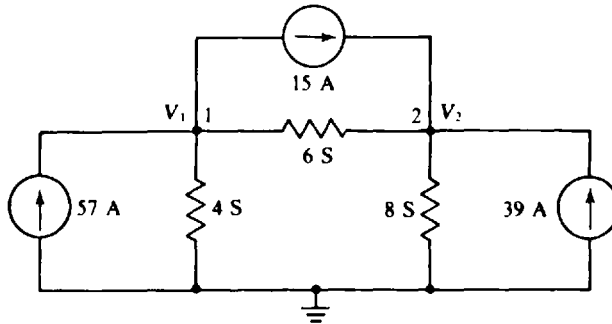

Fig. 4-24

The self-conductance of node 1 is $6 + 4 = 10 \text{ S}$. The conductance mutual with node 2 is 6 S , and the sum of the currents into node 1 from current sources is $57 - 15 = 42 \text{ A}$. So, the node 1 KCL equation is $10V_1 - 6V_2 = 42$.

Similarly, for node 2 the self-conductance is $6 + 8 = 14 \text{ S}$, the mutual conductance is 6 S , and the sum of the input currents from current sources is $39 + 15 = 54 \text{ A}$. These give a node 2 KCL equation of $-6V_1 + 14V_2 = 54$.

Placing the two nodal equations together shows the symmetry of the coefficients (-6 here) about the principal diagonal as a result of the same mutual conductance coefficient in both equations:

$$\begin{aligned} 10V_1 - 6V_2 &= 42 \\ -6V_1 + 14V_2 &= 54 \end{aligned}$$

Three times the first equation added to five times the second eliminates V_1 . The result is

$$-18V_2 + 70V_2 = 126 + 270 \quad \text{from which} \quad V_2 = \frac{396}{52} = 7.62 \text{ V}$$

This substituted into the first equation gives

$$10V_1 - 6(7.62) = 42 \quad \text{and} \quad V_1 = \frac{87.7}{10} = 8.77 \text{ V}$$

4.22 Use nodal analysis in finding I in the circuit of Fig. 4-25.

The controlling quantity I in terms of node voltages is $I = V_2/6$. Consequently, the dependent current source provides a current of $0.5I = 0.5(V_2/6) = V_2/12$, and the dependent voltage source provides a voltage of $12I = 12(V_2/6) = 2V_2$.

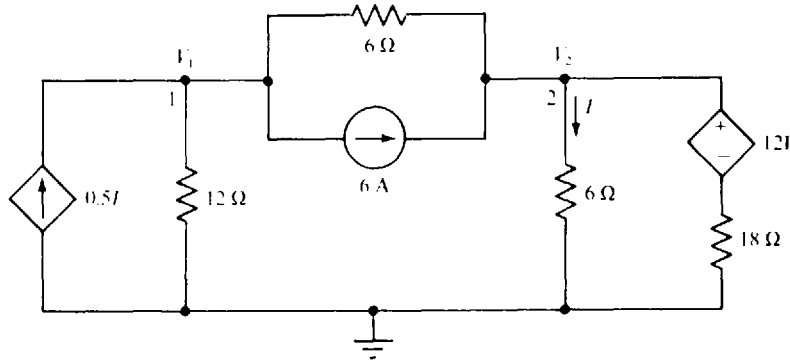

Fig. 4-25

Because of the presence of the dependent sources, it may be best to apply KCL at nodes 1 and 2 on a branch-to-branch basis instead of attempting to use a shortcut method. Doing this gives

$$\frac{-V_2}{12} + \frac{I_1}{12} + \frac{I_1 - I_2}{6} = -6 \quad \text{and} \quad \frac{I_2 - I_1}{6} + \frac{I_2}{6} + \frac{I_2 - 2I_2}{18} = 6$$

These simplify to

$$3V_1 - 3V_2 = -72 \quad \text{and} \quad -3V_1 + 5V_2 = 108$$

Adding these equations eliminates V_1 and results in $2V_2 = 36$ or $V_2 = 18$ V. Finally,

$$I = \frac{V_2}{6} = \frac{18}{6} = 3 \text{ A}$$

4.23 Find the node voltages in the circuit shown in Fig. 4-26.

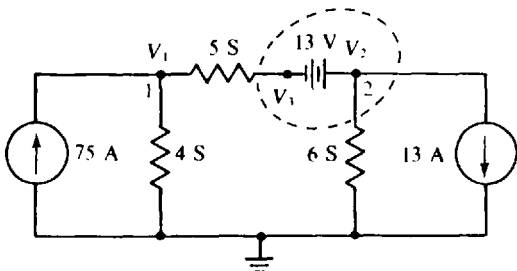

Fig. 4-26

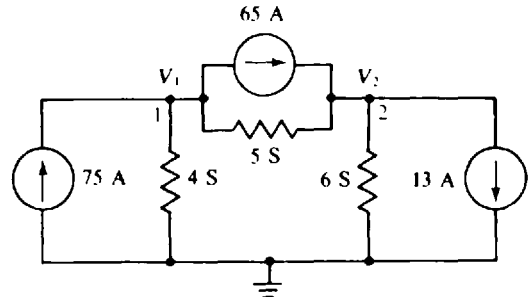

Fig. 4-27

One analysis approach is to transform the voltage source and series resistor to a current source and parallel resistor, as shown in the circuit of Fig. 4-27.

The self-conductance of node 1 is $4 + 5 = 9$ S, and that of node 2 is $5 + 6 = 11$ S. The mutual conductance is 5 S. The sum of the currents into node 1 from current sources is $75 - 65 = 10$ A, and that into node 2 is $65 - 13 = 52$ A. Thus, the corresponding nodal equations are

$$\begin{aligned} 9V_1 - 5V_2 &= 10 \\ -5V_1 + 11V_2 &= 52 \end{aligned}$$

Except for V 's instead of I 's, these are the same equations as for Prob. 4.12. Consequently, the answers are the same: $V_1 = 5$ V and $V_2 = 7$ V. Circuits having such similar equations are called *duals*.

From the original circuit shown in Fig. 4-26, the 13-V source makes V_3 13 V more negative than V_2 : $V_3 = V_2 - 13 = 7 - 13 = -6$ V.

Another approach is to apply the so-called *supernode method*, which is applicable for the nodal analyses of circuits that contain floating voltage sources. (A voltage source is floating if neither terminal is connected to ground.) For this method, each floating voltage source is enclosed in a separate loop, or closed surface, as shown in Fig. 4-26 for the 13-V source. Then KCL is applied to each closed surface as well as to the nongrounded nodes to which no other voltage sources are connected.

For the circuit of Fig. 4-26, KCL can be applied to node 1 in the usual fashion. The result is $9V_1 - 5V_3 = 75$. For a supernode, it is best not to use any shortcuts but instead to consider each branch current. For the supernode shown this gives $6V_2 + 5(V_3 - V_1) = -13$. Another independent equation is needed. It can be obtained from the voltage drop across the floating voltage source: $V_2 - V_3 = 13$. So, the two KCL equations are augmented with a single KVL equation. In matrix form these equations are

$$\begin{bmatrix} 9 & 0 & -5 \\ -5 & 6 & 5 \\ 0 & 1 & -1 \end{bmatrix} \begin{bmatrix} V_1 \\ V_2 \\ V_3 \end{bmatrix} = \begin{bmatrix} 75 \\ -13 \\ 13 \end{bmatrix}$$

The solutions are, of course, the same: $V_1 = 5$ V, $V_2 = 7$ V, and $V_3 = -6$ V.

In general, for the supernode approach, the KCL equations must be augmented with KVL equations, the number of which is equal to the number of floating voltage sources.

4.24 Use nodal analysis to obtain the node voltages V_1 and V_2 in the circuit of Fig. 4-28.

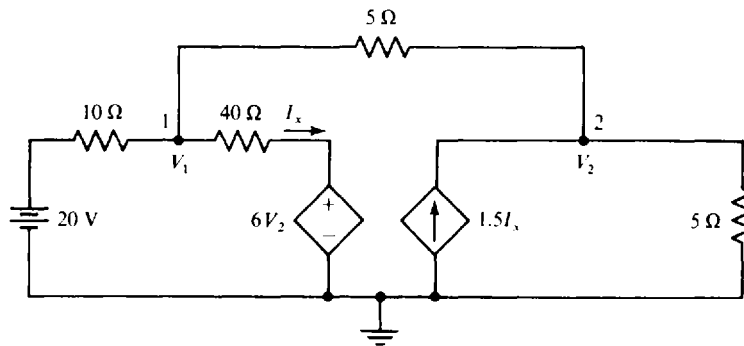

Fig. 4-28

The controlling current I_x expressed in terms of node voltages is $I_x = (V_1 - 6V_2)/40$. So, the dependent current source provides a current of $1.5I_x = 1.5(V_1 - 6V_2)/40$. Applying KCL to nodes 1 and 2 produces

$$\frac{V_1 - 20}{10} + \frac{V_1 - V_2}{5} + \frac{V_1 - 6V_2}{40} = 0 \quad \text{and} \quad \frac{V_2 - V_1}{5} - \frac{1.5(V_1 - 6V_2)}{40} + \frac{V_2}{5} = 0$$

These simplify to

$$13V_1 - 14V_2 = 80 \quad \text{and} \quad -9.5V_1 + 25V_2 = 0$$

which have solutions of $V_1 = 10.4$ V and $V_2 = 3.96$ V, as can easily be obtained.

The circuit of Fig. 4-28 is the same as that of Fig. 4-20 of Prob. 4.16 in which mesh analysis was used. Observe that nodal analysis is easier to apply than mesh analysis since there is one less equation and the equations are easier to obtain. Often, but not always, one analysis method is best. The ability to select the best analysis method comes mostly from experience. The first step should always be to check the number of required equations for the various analysis methods: mesh, loop, and nodal.

4.25 Obtain the nodal equations for the circuit shown in Fig. 4-29.

The self-conductances are $3 + 4 = 7$ S for node 1, $4 + 5 + 6 = 15$ S for node 2, and $6 + 7 = 13$ S for node 3. The mutual conductances are 4 S for nodes 1 and 2, 6 S for nodes 2 and 3, and 0 S for

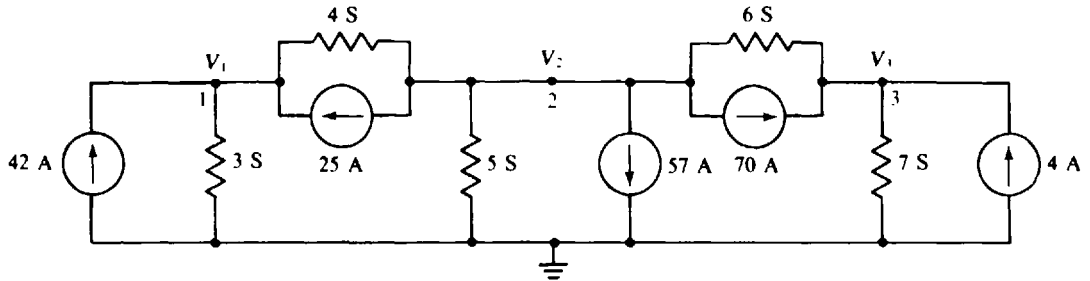

Fig. 4-29

nodes 1 and 3. The currents flowing into the nodes from current sources are $42 + 25 = 67$ A for node 1, $-25 - 57 - 70 = -152$ A for node 2, and $70 + 4 = 74$ A for node 3. So, the nodal equations are

$$\begin{aligned} 7V_1 - 4V_2 - 0V_3 &= 67 \\ -4V_1 + 15V_2 - 6V_3 &= -152 \\ 0V_1 - 6V_2 + 13V_3 &= 74 \end{aligned}$$

Notice the symmetry of coefficients about the principal diagonal. This symmetry always occurs for circuits that do not have dependent sources.

Since this set of equations is the same as that for Prob. 4.13, except for having V 's instead of I 's, the answers are the same: $V_1 = 5$ V, $V_2 = -8$ V, and $V_3 = 2$ V.

4.26 Obtain the nodal equations for the circuit shown in Fig. 4-30.

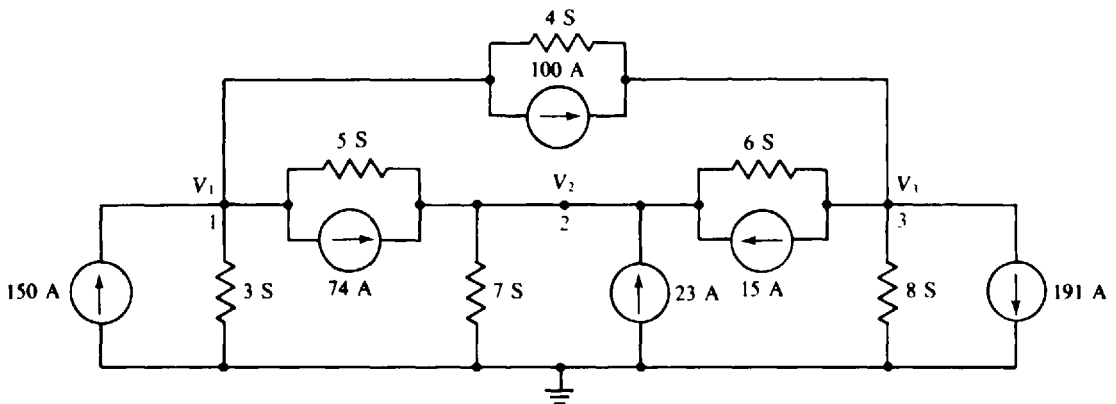

Fig. 4-30

The self-conductances are $3 + 4 + 5 = 12$ S for node 1, $5 + 6 + 7 = 18$ S for node 2, and $6 + 4 + 8 = 18$ S for node 3. The mutual conductances are 5 S for nodes 1 and 2, 6 S for nodes 2 and 3, and 4 S for nodes 1 and 3. The currents into the nodes from current sources are $150 - 100 - 74 = -24$ A for node 1, $74 + 15 + 23 = 112$ A for node 2, and $100 - 191 - 15 = -106$ A for node 3. So, the nodal equations are

$$\begin{aligned} 12V_1 - 5V_2 - 4V_3 &= -24 \\ -5V_1 + 18V_2 - 6V_3 &= 112 \\ -4V_1 - 6V_2 + 18V_3 &= -106 \end{aligned}$$

As a check, notice the symmetry of the coefficients about the principal diagonal.

Since these equations are basically the same as those in Prob. 4.14, the answers are the same: $V_1 = -2$ V, $V_2 = 4$ V, and $V_3 = -5$ V.

4.27 Figure 4-31 shows a transistor with a bias circuit. If $I_C = 50I_B$ and if $V_{BE} = 0.7$ V, find V_{CE} .

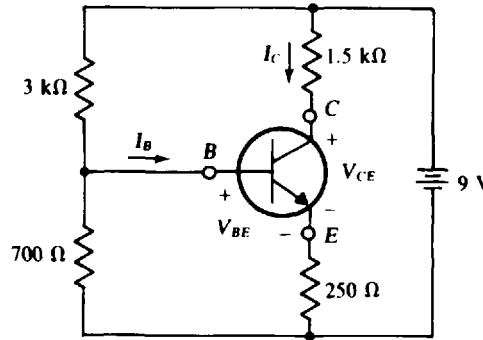

Fig. 4-31

Perhaps the best way to find V_{CE} is to first find I_B and I_C , and from them the voltage drops across the 1.5-k Ω and 250- Ω resistors. Then, use KVL on the right-hand mesh and obtain V_{CE} from 9 V minus these two drops.

I_B can be found from the two left-hand meshes. The current through the 250- Ω resistor is $I_C + I_B = 50I_B + I_B = 51I_B$, giving a voltage drop of $(51I_B)(250)$. This drop added to V_{BE} is the drop across the 700- Ω resistor. Thus, the current through this resistor is $[0.7 + (51I_B)(250)]/700$. From KCL applied at the left-hand node, this current plus I_B is the total current flowing through the 3-k Ω resistor. The voltage drop across this resistor added to the drop across the 700- Ω resistor equals 9 V, as is evident from the outside loop:

$$\left[\frac{0.7 + (51I_B)(250)}{700} + I_B \right] (3000) + 0.7 + (51I_B)(250) = 9$$

From this, $I_B = 75.3 \mu\text{A}$. So, $I_C = 50I_B = 3.76 \text{ mA}$ and

$$V_{CE} = 9 - 1500I_C - 250(I_C + I_B) = 2.39 \text{ V}$$

Supplementary Problems

4.28 Evaluate the following determinants:

$$(a) \begin{vmatrix} 4 & 3 \\ -2 & -6 \end{vmatrix} \quad (b) \begin{vmatrix} 8 & -30 \\ 42 & 56 \end{vmatrix}$$

Ans. (a) -18, (b) 1708

4.29 Evaluate the following determinants:

$$(a) \begin{vmatrix} 16 & 0 & -25 \\ -32 & 15 & -19 \\ 13 & 21 & -18 \end{vmatrix} \quad (b) \begin{vmatrix} -27 & 33 & -45 \\ -52 & 64 & -73 \\ 18 & -92 & 46 \end{vmatrix}$$

Ans. (a) 23 739, (b) -26 022

4.30 Use Cramer's rule to solve for the unknowns in

$$(a) \begin{cases} 26V_1 - 18V_2 = -124 \\ -18V_1 + 30V_2 = 156 \end{cases} \quad (b) \begin{cases} 16I_1 - 12I_2 = 560 \\ -12I_1 + 21I_2 = -708 \end{cases}$$

Ans. (a) $V_1 = -2$ V, $V_2 = 4$ V; (b) $I_1 = 17$ A, $I_2 = -24$ A

4.31 Without using Cramer's rule or the matrix-calculator approach, solve for the unknowns in

$$(a) \quad \begin{aligned} 44I_1 - 28I_2 &= -704 \\ -28I_1 + 37I_2 &= 659 \end{aligned} \quad (b) \quad \begin{aligned} 62V_1 - 42V_2 &= 694 \\ -42V_1 + 77V_2 &= 161 \end{aligned}$$

Ans. (a) $I_1 = -9$ A, $I_2 = 11$ A; (b) $V_1 = 20$ V, $V_2 = 13$ V

4.32 Use Cramer's rule to solve for the unknowns in

$$\begin{aligned} 26V_1 - 11V_2 - 9V_3 &= -166 \\ -11V_1 + 45V_2 - 23V_3 &= 1963 \\ -9V_1 - 23V_2 + 56V_3 &= -2568 \end{aligned}$$

Ans. $V_1 = -11$ V, $V_2 = 21$ V, $V_3 = -39$ V

4.33 What is the current-source equivalent of a 12-V battery with a 0.5- Ω internal resistance?

Ans. $I = 24$ A, $R = 0.5$ Ω

4.34 What is the voltage-source equivalent of a 3-A current source in parallel with a 2-k Ω resistor?

Ans. $V = 6$ kV, $R = 2$ k Ω

4.35 Use repeated source transformations in obtaining I in the circuit of Fig. 4-32.

Ans. 2 A

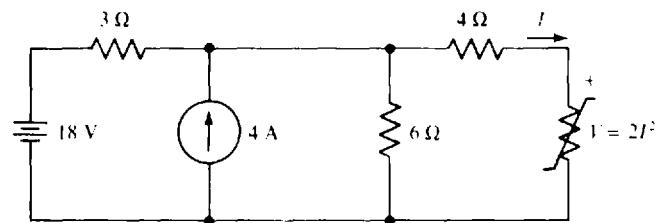

Fig. 4-32

4.36 Find the mesh currents in the circuit shown in Fig. 4-33.

Ans. $I_1 = 3$ A, $I_2 = -8$ A, $I_3 = 7$ A

4.37 Solve for the mesh currents in the circuit shown in Fig. 4-34.

Ans. $I_1 = 5$ mA, $I_2 = -2$ mA

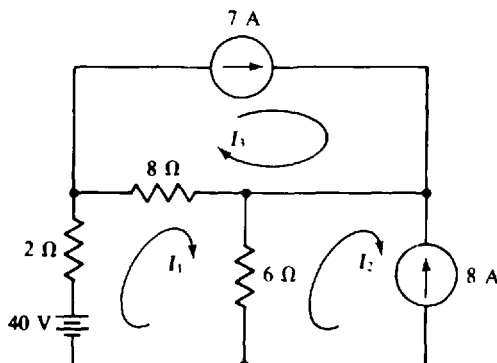

Fig. 4-33

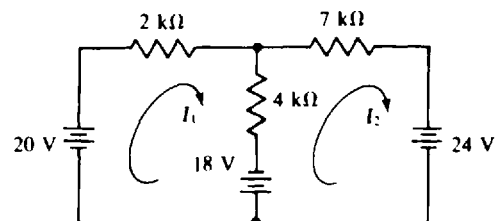

Fig. 4-34

4.38 Repeat Prob. 4.37 with the 24-V source changed to -1 V.

Ans. $I_1 = 7$ mA, $I_2 = 1$ mA

4.39 Two 12-V batteries in parallel provide current to a light bulb that has a hot resistance of 0.5Ω . If the battery internal resistances are 0.1 and 0.2Ω , find the power consumed by the light bulb.

Ans. 224 W

4.40 Determine I_x in the circuit of Fig. 4-35.

Ans. -4.86 mA

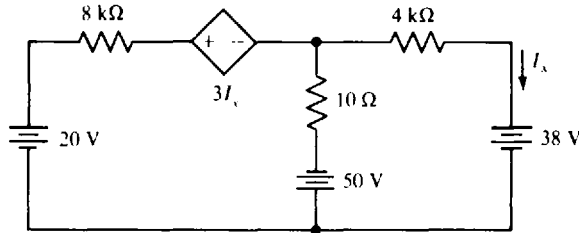

Fig. 4-35

4.41 Calculate the mesh currents in the circuit of Fig. 4-36.

Ans. $I_1 = 2$ mA, $I_2 = -3$ mA, $I_3 = 4$ mA

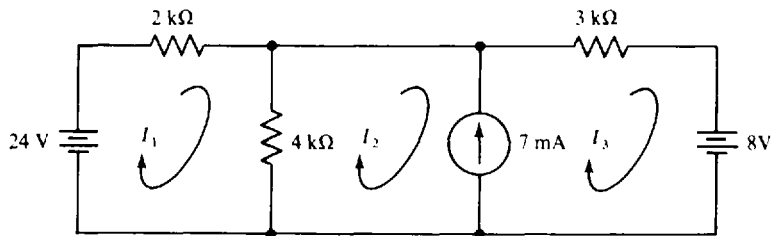

Fig. 4-36

4.42 Find the mesh currents in the circuit shown in Fig. 4-37.

Ans. $I_1 = -2$ mA, $I_2 = 6$ mA, $I_3 = 4$ mA

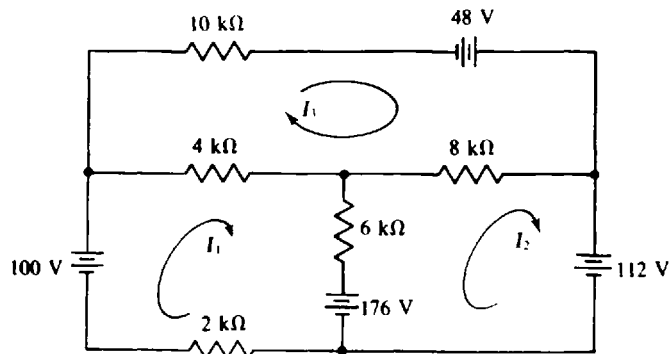

Fig. 4-37

- 4.43** Double the voltages of the voltage sources in the circuit shown in Fig. 4-37 and redetermine the mesh currents. Compare them with the original mesh currents.

Ans. $I_1 = -4 \text{ mA}$, $I_2 = 12 \text{ mA}$, $I_3 = 8 \text{ mA}$, double

- 4.44** Double the resistances of the resistors in the circuit shown in Fig. 4-37 and redetermine the mesh currents. Compare them with the original mesh currents.

Ans. $I_1 = -1 \text{ mA}$, $I_2 = 3 \text{ mA}$, $I_3 = 2 \text{ mA}$, half

- 4.45** Repeat Prob. 4.42 with the three voltage-source changes of 176 to 108 V, 112 to 110 V, and 48 to 66 V.

Ans. $I_1 = 3 \text{ mA}$, $I_2 = 4 \text{ mA}$, $I_3 = 5 \text{ mA}$

- 4.46** For a certain three-mesh circuit, the self-resistances are 20, 25, and 32 Ω for meshes 1, 2, and 3, respectively. The mutual resistances are 10 Ω for meshes 1 and 2, 12 Ω for meshes 2 and 3, and 6 Ω for meshes 1 and 3. The aiding voltages from voltage sources are -74, 227, and -234 V for meshes 1, 2, and 3, respectively. Find the mesh currents.

Ans. $I_1 = -3 \text{ A}$, $I_2 = 5 \text{ A}$, $I_3 = -6 \text{ A}$

- 4.47** Repeat Prob. 4.46 for the same self-resistances and mutual resistances, but for aiding source voltages of 146, -273, and 182 V for meshes 1, 2, and 3, respectively.

Ans. $I_1 = 5 \text{ A}$, $I_2 = -7 \text{ A}$, $I_3 = 4 \text{ A}$

- 4.48** Obtain the mesh currents in the circuit of Fig. 4-38.

Ans. $I_1 = -0.879 \text{ mA}$, $I_2 = -6.34 \text{ mA}$, $I_3 = -10.1 \text{ mA}$

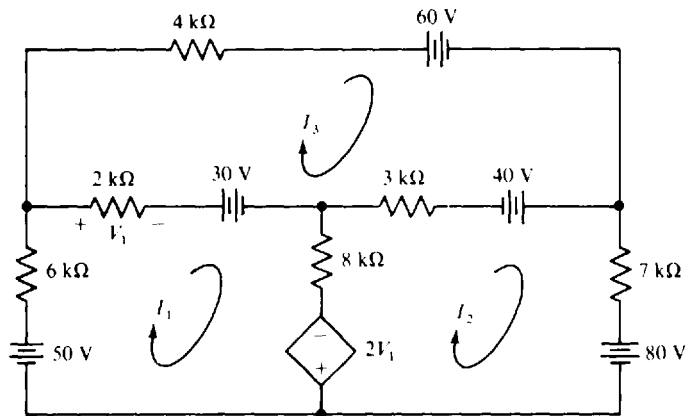

Fig. 4-38

- 4.49** Determine the mesh currents in the circuit of Fig. 4-39.

Ans. $I_1 = -3.26 \text{ mA}$, $I_2 = -1.99 \text{ mA}$, $I_3 = 1.82 \text{ mA}$

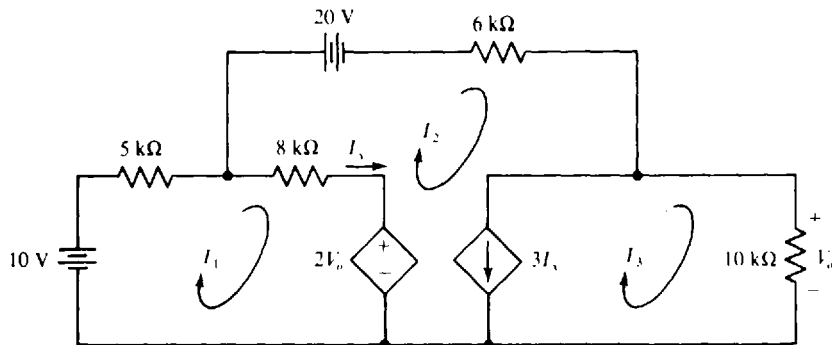

Fig. 4-39

4.50 Use loop analysis to find the current flowing down through the 6-Ω resistor in the circuit shown in Fig. 4-33.

Ans. 11 A

4.51 Use loop analysis to find the current flowing to the right through the 8-kΩ resistor in the circuit shown in Fig. 4-37.

Ans. 2 mA

4.52 Use loop analysis to find the current I in the circuit shown in Fig. 4-40.

Ans. 0.375 A

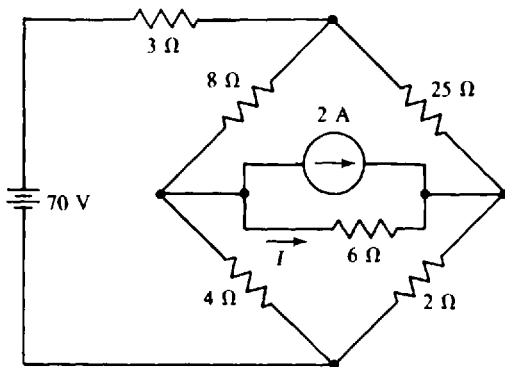

Fig. 4-40

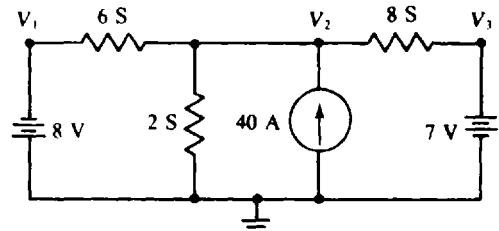

Fig. 4-41

4.53 Obtain the node voltages in the circuit shown in Fig. 4-41.

Ans. $V_1 = -8$ V, $V_2 = 3$ V, $V_3 = 7$ V

4.54 Find the node voltages in the circuit shown in Fig. 4-42.

Ans. $V_1 = 5$ V, $V_2 = -2$ V

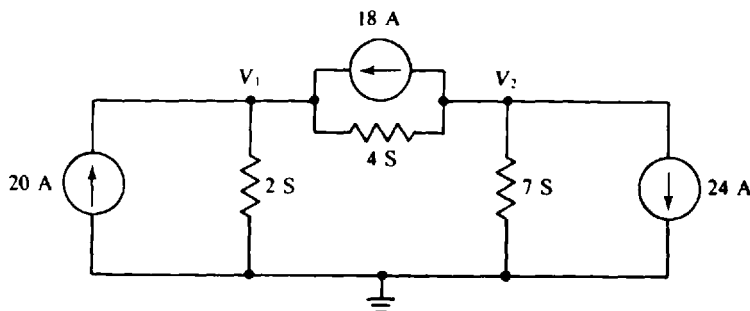

Fig. 4-42

4.55 Double the currents from the current sources in the circuit shown in Fig. 4-42 and redetermine the node voltages. Compare them with the original node voltages.

Ans. $V_1 = 10$ V, $V_2 = -4$ V, double

4.56 Double the conductances of the resistors in the circuit shown in Fig. 4-42 and redetermine the node voltages. Compare them with the original node voltages.

Ans. $V_1 = 2.5$ V, $V_2 = -1$ V, half

4.57 Repeat Prob. 4.54 with the 24-A source changed to -1 A.

Ans. $V_1 = 7$ V, $V_2 = 1$ V

4.58 Find V_0 for the circuit shown in Fig. 4-43.

Ans. -50 V

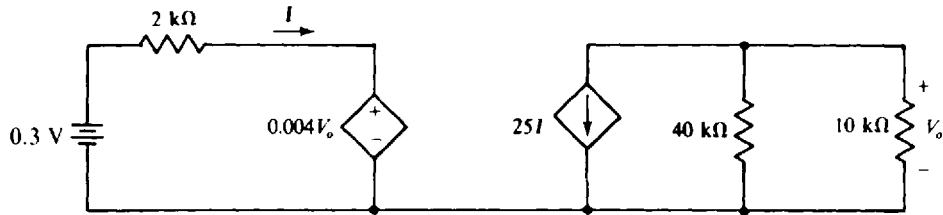

Fig. 4-43

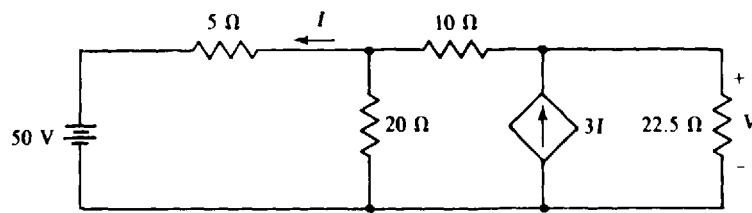

Fig. 4-44

4.59 Find V in the circuit shown in Fig. 4-44.

Ans. 180 V

4.60 Calculate the node voltages in the circuit of Fig. 4-45.

Ans. $V_1 = -63.5$ V, $V_2 = 105.9$ V

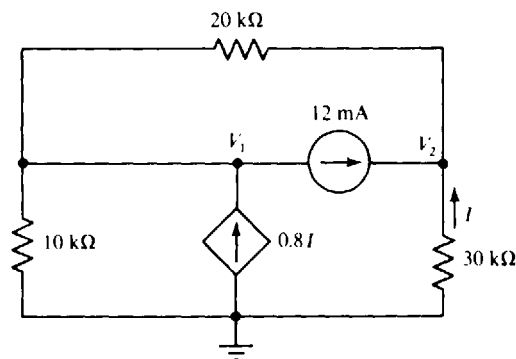

Fig. 4-45

4.61 Find the voltages V_1 , V_2 , and V_3 in the circuit shown in Fig. 4-46.

Ans. $V_1 = 5$ V, $V_2 = -2$ V, $V_3 = 3$ V

4.62 Find the node voltages in the circuit shown in Fig. 4-47.

Ans. $V_1 = -2$ V, $V_2 = 6$ V, $V_3 = 4$ V

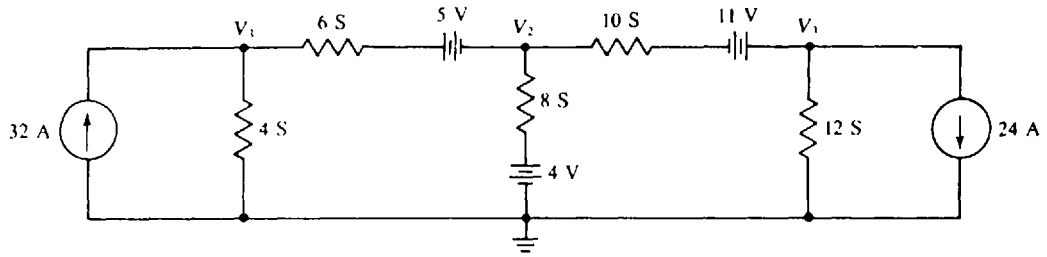

Fig. 4-46

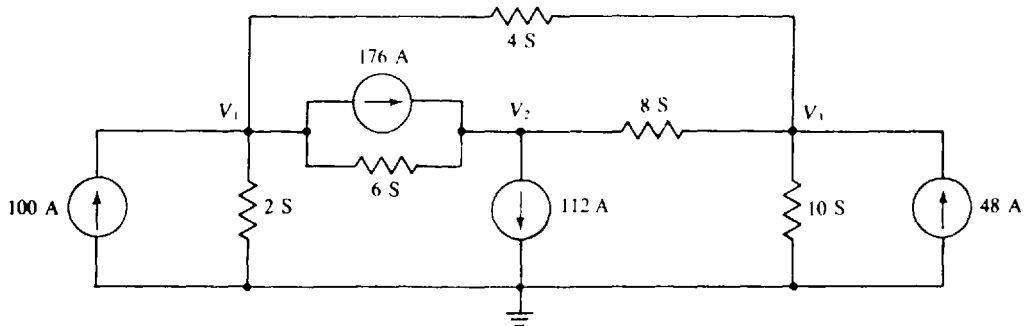

Fig. 4-47

4.63 Repeat Prob. 4.62 with the three current-source changes of 176 to 108 A, 112 to 110 A, and 48 to 66 A.

Ans. $V_1 = 3 \text{ V}$, $V_2 = 4 \text{ V}$, $V_3 = 5 \text{ V}$

4.64 For a certain four-node circuit, including a ground node, the self-conductances are 40, 50, and 64 S for nodes 1, 2, and 3, respectively. The mutual conductances are 20 S for nodes 1 and 2, 24 S for nodes 2 and 3, and 12 S for nodes 1 and 3. Currents flowing in current sources connected to these nodes are 74 A away from node 1, 227 A into node 2, and 234 A away from node 3. Find the node voltages.

Ans. $V_1 = -1.5 \text{ V}$, $V_2 = 2.5 \text{ V}$, $V_3 = -3 \text{ V}$

4.65 Repeat Prob. 4.64 for the same self-conductances and mutual conductances, but for source currents of 292 A into node 1, 546 A away from node 2, and 364 A into node 3.

Ans. $V_1 = 5 \text{ V}$, $V_2 = -7 \text{ V}$, $V_3 = 4 \text{ V}$

4.66 In the circuit shown in Fig. 4-48, find V_{Ct} if $I_C = 30I_B$ and $V_{BE} = 0.7 \text{ V}$.

Ans. 3.68 V

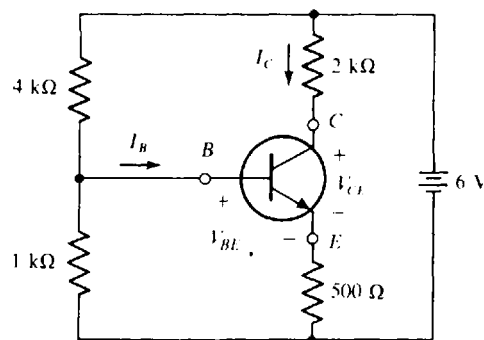

Fig. 4-48

4.67 Repeat Prob. 4.66 with the dc voltage source changed to 9 V and the collector resistor changed from 2 kΩ to 2.5 kΩ.

Ans. 2.89 V

DC Equivalent Circuits, Network Theorems, and Bridge Circuits

INTRODUCTION

Network theorems are often important aids for network analyses. Some theorems apply only to linear, bilateral circuits, or portions of them. A *linear* electric circuit is constructed of linear electric elements as well as of independent sources. A linear electric element has an excitation-response relation such that doubling the excitation doubles the response, tripling the excitation triples the response, and so on. A *bilateral* circuit is constructed of bilateral elements as well as of independent sources. A bilateral element operates the same upon reversal of the excitation, except that the response also reverses. Resistors are both linear and bilateral if they have voltage-current relations that obey Ohm's law. On the other hand, a diode, which is a common electronic component, is neither linear nor bilateral.

Some theorems require deactivation of independent sources. The term *deactivation* refers to replacing all *independent* sources by their internal resistances. In other words, all ideal voltage sources are replaced by short circuits, and all ideal current sources by open circuits. Internal resistances are not affected, nor are *dependent* sources. *Dependent sources are never deactivated in the application of any theorem.*

THÉVENIN'S AND NORTON'S THEOREMS

Thévenin's and Norton's theorems are probably the most important network theorems. For the application of either of them, a network is divided into two parts, *A* and *B*, as shown in Fig. 5-1a, with two joining wires. One part must be linear and bilateral, but the other part can be anything.

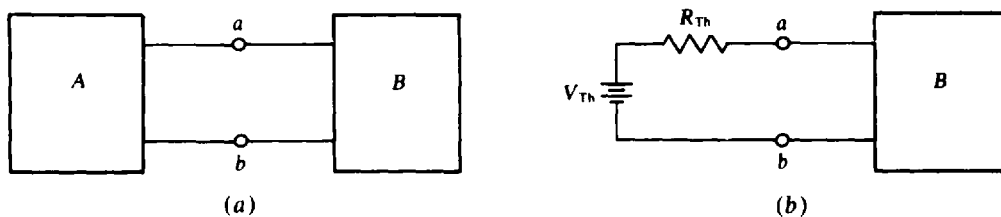

Fig. 5-1

Thévenin's theorem specifies that the linear, bilateral part, say part *A*, can be replaced by a *Thévenin equivalent circuit* consisting of a voltage source and a resistor in series, as shown in Fig. 5-1b, without any changes in voltages or currents in part *B*. The voltage V_{Th} of the voltage source is called the *Thévenin voltage*, and the resistance R_{Th} of the resistor is called the *Thévenin resistance*.

As should be apparent from Fig. 5-1b, V_{Th} is the voltage across terminals *a* and *b* if part *B* is replaced by an open circuit. So, if the wires are cut at terminals *a* and *b* in either circuit shown in Fig. 5-1, and if a voltmeter is connected to measure the voltage across these terminals, the voltmeter reading is V_{Th} . This voltage is almost always different from the voltage across terminals *a* and *b* with part *B* connected. The Thévenin or open-circuit voltage V_{Th} is sometimes designated by V_{OC} .

With the joining wires cut, as shown in Fig. 5-2a, R_{Th} is the resistance of part *A* with all independent sources deactivated. In other words, if all independent sources in part *A* are replaced by their internal resistances, an ohmmeter connected to terminals *a* and *b* reads Thévenin's resistance.

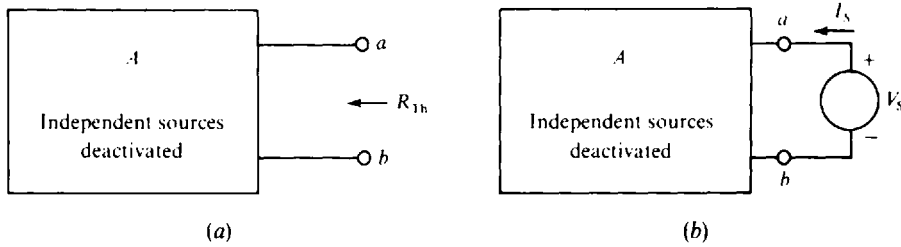

Fig. 5-2

If in Fig. 5-2a the resistors in part *A* are in a parallel-series configuration, then R_{Th} can be obtained readily by combining resistances. If, however, part *A* contains dependent sources (remember, they are *not* deactivated), then, of course, resistance combination is not applicable. But in this case the approach shown in Fig. 5-2b can be used. An independent source is applied, either voltage or current and of any value, and R_{Th} obtained from the resistance “seen” by this source. Mathematically,

$$R_{Th} = \frac{V_s}{I_s}$$

So, if a source of voltage V_s is applied, then I_s is calculated for this ratio. And if a source of current I_s is applied, then V_s is calculated. The preferred source, if any, depends on the configuration of part *A*.

Thévenin’s theorem guarantees only that the voltages and currents in part *B* do not change when part *A* is replaced by its Thévenin equivalent circuit. The voltages and currents in the Thévenin circuit itself are almost always different from those in the original part *A*, except at terminals *a* and *b* where they are the same, of course.

Although R_{Th} is often determined by finding the resistance at terminals *a* and *b* with the connecting wires cut and the independent sources deactivated, it can also be found from the current I_{sc} that flows in a short circuit placed across terminals *a* and *b*, as shown in Fig. 5-3a. As is apparent from Fig. 5-3b, this short-circuit current from terminal *a* to *b* is related to the Thévenin voltage and resistance. Specifically,

$$R_{Th} = \frac{V_{Th}}{I_{sc}}$$

So, R_{Th} is equal to the ratio of the open-circuit voltage at terminals *a* and *b* and the short-circuit current between them. With this approach to determining R_{Th} , no sources are deactivated.

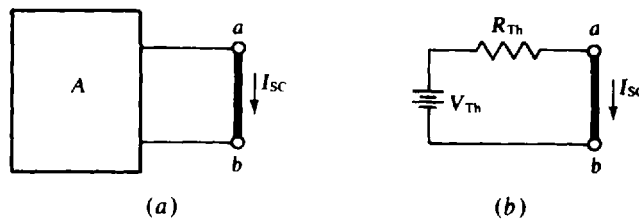

Fig. 5-3

From $V_{Th} = I_{sc}R_{Th}$, it is evident that the Thévenin equivalent can be obtained by determining any two of the quantities V_{Th} , I_{sc} , and R_{Th} . Common sense dictates that the two used should be the two that are the easiest to determine.

The *Norton equivalent circuit* can be derived by applying a source transformation to the Thévenin equivalent circuit, as illustrated in Fig. 5-4a. The Norton equivalent circuit is sometimes illustrated as in Fig. 5-4b, in which $I_N = V_{Th} / R_{Th}$ and $R_N = R_{Th}$. Notice that, if a short circuit is placed across terminals *a* and *b* in the circuit shown in Fig. 5-4b, the short-circuit current I_{sc} from terminal *a* to *b* is

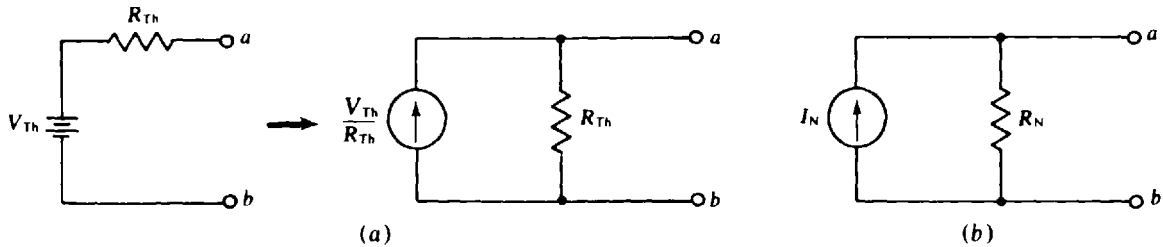

Fig. 5-4

equal to the Norton current I_N . Often in circuit diagrams, the notation I_{SC} is used for the source current instead of I_N . Also, often R_{Th} is used for the resistance instead of R_N .

In electronic circuit literature, an electronic circuit with a load is often described as having an *output resistance* R_{out} . If the load is disconnected and if the source at the input of the electronic circuit is replaced by its internal resistance, then the output resistance R_{out} of the electronic circuit is the resistance “looking in” at the load terminals. Clearly, it is the same as the Thévenin resistance.

An electronic circuit also has an input resistance R_{in} , which is the resistance that appears at the input of the circuit. In other words, it is the resistance “seen” by the source. Since an electronic circuit typically contains the equivalent of dependent sources, the input resistance is determined in the same way that a Thévenin resistance is often obtained by applying a source and determining the ratio of the source voltage to the source current.

MAXIMUM POWER TRANSFER THEOREM

The *maximum power transfer theorem* specifies that a resistive load receives maximum power from a linear, bilateral dc circuit if the load resistance equals the Thévenin resistance of the circuit as “seen” by the load. The proof is based on calculus. Selecting the load resistance to be equal to the circuit Thévenin resistance is called *matching* the resistances. With matching, the load voltage is $V_{Th}/2$, and so the power consumed by the load is $(V_{Th}/2)^2/R_{Th} = V_{Th}^2/4R_{Th}$.

SUPERPOSITION THEOREM

The *superposition theorem* specifies that, in a linear circuit containing several independent sources, the current or voltage of a circuit element equals the *algebraic sum* of the component voltages or currents produced by the independent sources acting alone. Put another way, the voltage or current contribution from each independent source can be found separately, and then all the contributions algebraically added to obtain the actual voltage or current with all independent sources in the circuit.

This theorem applies only to independent sources—not to dependent ones. Also, it applies only to finding voltages and currents. In particular, it cannot be used to find power in dc circuits. Additionally, the theorem applies to each independent source acting alone, which means that the other independent sources must be deactivated. In practice, though, it is not essential that the independent sources be considered one at a time; any number can be considered simultaneously.

Because applying the superposition theorem requires several analyses, more work may be done than with a single mesh, loop, or nodal analysis with all sources present. So, using the superposition theorem in a dc analysis is seldom advantageous. It can be useful, though, in the analyses of some of the operational-amplifier circuits of the next chapter.

MILLMAN'S THEOREM

Millman's theorem is a method for reducing a circuit by combining parallel voltage sources into a single voltage source. It is just a special case of the application of Thévenin's theorem.

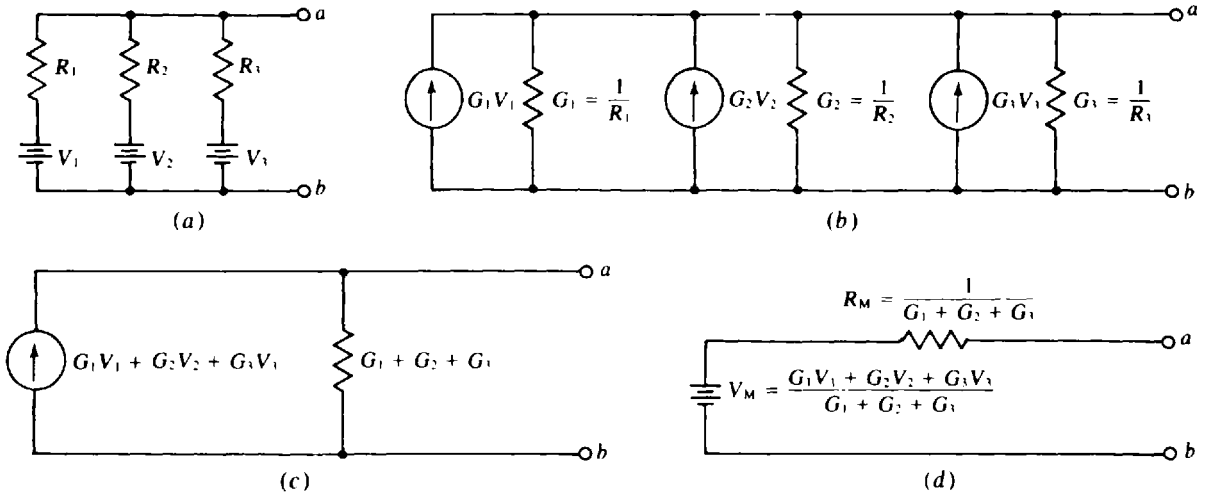

Fig. 5-5

Figure 5-5 illustrates the theorem for only three parallel voltage sources, but the theorem applies to any number of such sources. The derivation of Millman's theorem is simple. If the voltage sources shown in Fig. 5-5a are transformed to current sources (Fig. 5-5b) and the currents added, and if the conductances are added, the result is a single current source of $G_1V_1 + G_2V_2 + G_3V_3$ in parallel with a resistor having a conductance of $G_1 + G_2 + G_3$ (Fig. 5-5c). Then, the transformation of this current source to a voltage source gives the final result indicated in Fig. 5-5d. In general, for N parallel voltage sources the Millman voltage source has a voltage of

$$V_M = \frac{G_1V_1 + G_2V_2 + \dots + G_NV_N}{G_1 + G_2 + \dots + G_N}$$

and the Millman series resistor has a resistance of

$$R_M = \frac{1}{G_1 + G_2 + \dots + G_N}$$

Note from the voltage source formula that, if all the sources have the same voltage, this voltage is also the Millman source voltage.

Y-Δ AND Δ-Y TRANSFORMATIONS

Figure 5-6a shows a Y (wye) resistor circuit and Fig. 5-6b a Δ (delta) resistor circuit. There are other names. If the Y circuit is drawn in the shape of a T, it is also called a T (tee) circuit. And if the Δ circuit is drawn in the shape of a Π, it is also called a Π (pi) circuit.

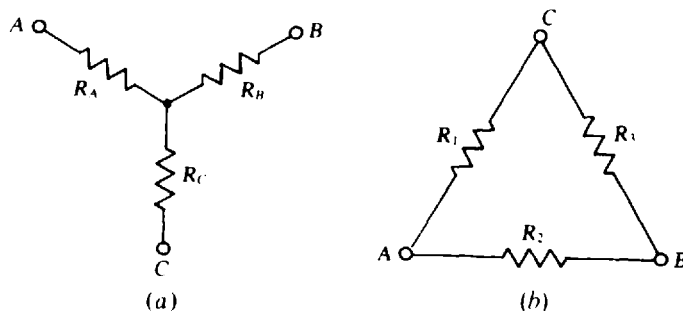

Fig. 5-6

It is possible to transform a Y to an equivalent Δ and also a Δ to an equivalent Y. The corresponding circuits are equivalent only for voltages and currents *external* to the Y and Δ circuits. Internally, the voltages and currents are different.

Transformation formulas can be found from equating resistances between two lines to a Δ and a Y when the third line to each is open. This equating is done three times, with a different line open each time. Some algebraic manipulation of the results produces the following Δ -to-Y transformation formulas:

$$R_A = \frac{R_1 R_2}{R_1 + R_2 + R_3} \quad R_B = \frac{R_2 R_3}{R_1 + R_2 + R_3} \quad R_C = \frac{R_1 R_3}{R_1 + R_2 + R_3}$$

Also produced are the following Y-to- Δ transformation formulas:

$$R_1 = \frac{R_A R_B + R_A R_C + R_B R_C}{R_B} \quad R_2 = \frac{R_A R_B + R_A R_C + R_B R_C}{R_C} \quad R_3 = \frac{R_A R_B + R_A R_C + R_B R_C}{R_A}$$

Notice in the Δ -to-Y transformation formulas that the denominators are the same: $R_1 + R_2 + R_3$, the sum of the Δ resistances. In the Y-to- Δ transformation formulas, the numerators are the same: $R_A R_B + R_A R_C + R_B R_C$, the sum of the different products of the Y resistances taken two at a time.

Drawing the Y inside the Δ , as in Fig. 5-7, is a good aid for remembering the numerators of the Δ -to-Y transformation formulas and the denominators of the Y-to- Δ transformation formulas. For each Y resistor in the Δ -to-Y transformation formulas, the two resistances in each numerator product are those of the two Δ resistors adjacent to the Y resistor being found. In the Y-to- Δ transformation formulas, the single Y resistance in each denominator is that of the Y resistor opposite the Δ resistor being found.

If it happens that each Y resistor has the same value R_Y , then each resistance of the corresponding Δ is $3R_Y$, as the formulas give. And if each Δ resistance is R_Δ , then each resistance of the corresponding Y is $R_\Delta/3$. So, in this special but fairly common case, $R_\Delta = 3R_Y$ and, of course, $R_Y = R_\Delta/3$.

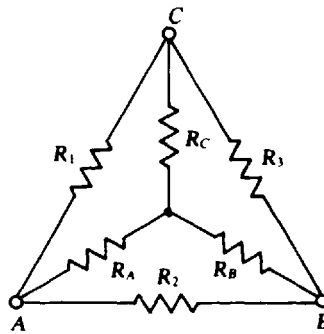

Fig. 5-7

BRIDGE CIRCUITS

As illustrated in Fig. 5-8a, a *bridge* resistor circuit has two joined Δ 's or, depending on the point of view, two joined Y's with a shared branch. Although the circuit usually appears in this form, the forms shown in Fig. 5-8b and c are also common. The circuit illustrated in Fig. 5-8c is often called a *lattice*. If a Δ part of a bridge is transformed to a Y, or a Y part transformed to a Δ , the circuit becomes series-parallel. Then the resistances can be easily combined, and the circuit reduced.

A bridge circuit can be used for precision resistance measurements. A *Wheatstone bridge* has a center branch that is a sensitive current indicator such as a galvanometer, as shown in Fig. 5-9. Three of the other branches are precision resistors, one of which is variable as indicated. The fourth branch is the resistor with the unknown resistance R_X that is to be measured.

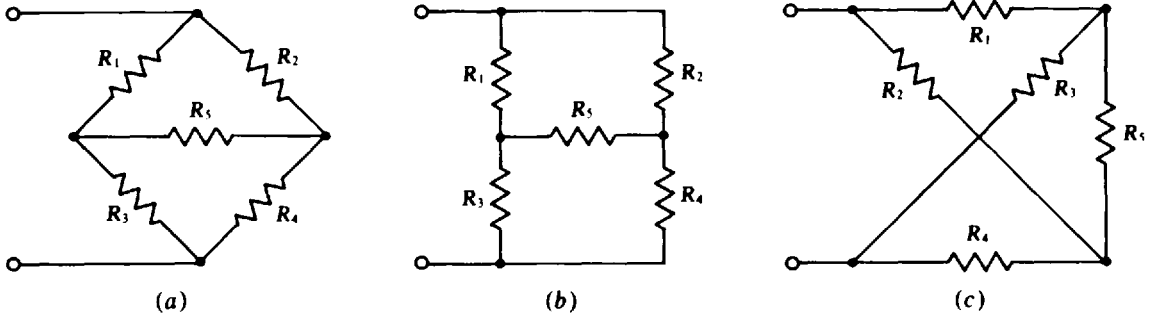

Fig. 5-8

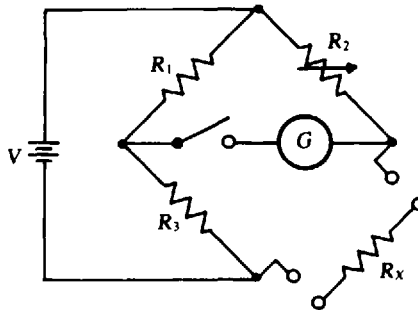

Fig. 5-9

For a resistance measurement, the resistance R_2 of the variable resistor is adjusted until the galvanometer needle does not deflect when the switch in the center branch is closed. This lack of deflection is the result of zero voltage across the galvanometer, and this means that, even with the switch open, the voltage across R_1 equals that across R_2 , and the voltage across R_3 equals that across R_X . In this condition the bridge is said to be *balanced*. By voltage division,

$$\frac{R_1 V}{R_1 + R_3} = \frac{R_2 V}{R_2 + R_X} \quad \text{and} \quad \frac{R_3 V}{R_1 + R_3} = \frac{R_X V}{R_2 + R_X}$$

Taking the ratio of the two equations produces the *bridge balance equation*:

$$R_X = \frac{R_2 R_3}{R_1}$$

Presumably, R_1 and R_3 are known standard resistances and a dial connected to R_2 gives this resistance so that R_X can be solved for. Of course, a commercial Wheatstone bridge has dials that directly indicate R_X upon balance.

A good way to remember the bridge balance equation is to equate products of the resistances of opposite branch arms: $R_1 R_X = R_2 R_3$. Another way is to equate the ratio of the top and bottom resistances of one side to that of the other: $R_1/R_3 = R_2/R_X$.

Solved Problems

- 5.1 A car battery has an open-circuit terminal voltage of 12.6 V. The terminal voltage drops to 10.8 V when the battery supplies 240 A to a starter motor. What is the Thévenin equivalent circuit for this battery?

The Thévenin voltage is the 12.6-V open-circuit voltage ($V_{Th} = 12.6$ V). The voltage drop when the battery supplies 240 A is the same drop that would occur across the Thévenin resistor in the Thévenin equivalent circuit because this resistor is in series with the Thévenin voltage source. From this drop,

$$R_{Th} = \frac{12.6 - 10.8}{240} = 7.5 \text{ m}\Omega$$

- 5.2** Find the Thévenin equivalent circuit for a dc power supply that has a 30-V terminal voltage when delivering 400 mA and a 27-V terminal voltage when delivering 600 mA.

For the Thévenin equivalent circuit, the terminal voltage is the Thévenin voltage minus the drop across the Thévenin resistor. Consequently, from the two specified conditions of operation,

$$V_{Th} - (400 \times 10^{-3})R_{Th} = 30$$

$$V_{Th} - (600 \times 10^{-3})R_{Th} = 27$$

Subtracting,

$$-(400 \times 10^{-3})R_{Th} + (600 \times 10^{-3})R_{Th} = 30 - 27$$

from which

$$R_{Th} = \frac{3}{200 \times 10^{-3}} = 15 \text{ }\Omega$$

This value of R_{Th} substituted into the first equation gives

$$V_{Th} - (400 \times 10^{-3})(15) = 30 \quad \text{or} \quad V_{Th} = 36 \text{ V}$$

- 5.3** Find the Thévenin equivalent circuit for a battery box containing four batteries with their positive terminals connected together and their negative terminals connected together. The open-circuit voltages and internal resistances of the batteries are 12.2 V and 0.5 Ω , 12.1 V and 0.1 Ω , 12.4 V and 0.16 Ω , and 12.4 V and 0.2 Ω .

The first step is to transform each voltage source to a current source. The result is four ideal current sources and four resistors, all in parallel. The next step is to add the currents from the current sources and also to add the conductances of the resistors, the effect of which is to combine the current sources into a single current source and the resistors into a single resistor. The final step is to transform this source and resistor to a voltage source in series with a resistor to obtain the Thévenin equivalent circuit.

The currents of the equivalent sources are

$$\frac{12.2}{0.5} = 24.4 \text{ A} \quad \frac{12.1}{0.1} = 121 \text{ A} \quad \frac{12.4}{0.16} = 77.5 \text{ A} \quad \frac{12.4}{0.2} = 62 \text{ A}$$

which add to

$$24.4 + 121 + 77.5 + 62 = 284.9 \text{ A}$$

The conductances add to

$$\frac{1}{0.5} + \frac{1}{0.1} + \frac{1}{0.16} + \frac{1}{0.2} = 23.25 \text{ S}$$

From this current and conductance, the Thévenin voltage and resistance are

$$V_{Th} = \frac{I}{G} = \frac{284.9}{23.25} = 12.3 \text{ V} \quad \text{and} \quad R_{Th} = \frac{1}{23.25} = 0.043 \text{ }\Omega$$

- 5.4** Find the Norton equivalent circuit for the power supply of Prob. 5.2 if the terminal voltage is 28 V instead of 27 V when the power supply delivers 600 mA.

For the Norton equivalent circuit, the load current is the Norton current minus the loss of current through the Norton resistor. Consequently, from the two specified conditions of operation,

$$I_N - \frac{30}{R_N} = 400 \times 10^{-3}$$

$$I_N - \frac{28}{R_N} = 600 \times 10^{-3}$$

Subtracting,

$$-\frac{30}{R_N} + \frac{28}{R_N} = 400 \times 10^{-3} - 600 \times 10^{-3}$$

or $-\frac{2}{R_N} = -200 \times 10^{-3}$ from which $R_N = \frac{2}{200 \times 10^{-3}} = 10 \Omega$

Substituting this into the first equation gives

$$I_N - \frac{30}{10} = 400 \times 10^{-3} \quad \text{and so} \quad I_N = 3.4 \text{ A}$$

- 5.5** What resistor draws a current of 5 A when connected across terminals *a* and *b* of the circuit shown in Fig. 5-10?

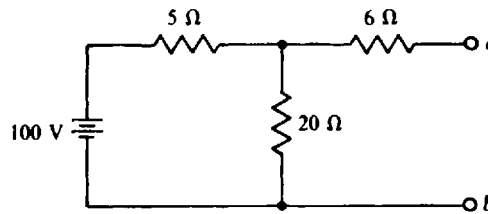

Fig. 5-10

A good approach is to use Thévenin's theorem to simplify the circuit to the Thévenin equivalent of a V_{Th} voltage source in series with an R_{Th} resistor. Then the load resistor R is in series with these, and Ohm's law can be used to find R :

$$5 = \frac{V_{Th}}{R_{Th} + R} \quad \text{from which} \quad R = \frac{V_{Th}}{5} - R_{Th}$$

The open-circuit voltage at terminals *a* and *b* is the voltage across the 20-Ω resistor since there is 0 V across the 6-Ω resistor because no current flows through it. By voltage division this voltage is

$$V_{Th} = \frac{20}{20 + 5} \times 100 = 80 \text{ V}$$

R_{Th} is the resistance at terminals *a* and *b* with the 100-V source replaced by a short circuit. This short circuit places the 5- and 20-Ω resistors in parallel for a net resistance of $5 \parallel 20 = 4 \Omega$. So, $R_{Th} = 6 + 4 = 10 \Omega$

With V_{Th} and R_{Th} known, the load resistance R for a 5-A current can be found from the previously derived equation:

$$R = \frac{V_{Th}}{5} - R_{Th} = \frac{80}{5} - 10 = 6 \Omega$$

- 5.6 In the circuit shown in Fig. 5-11, find the base current I_B if $I_C = 30I_B$. The base current is provided by a bias circuit consisting of 54- and 9.9-k Ω resistors and a 9-V source. There is a 0.7-V drop from base to emitter.

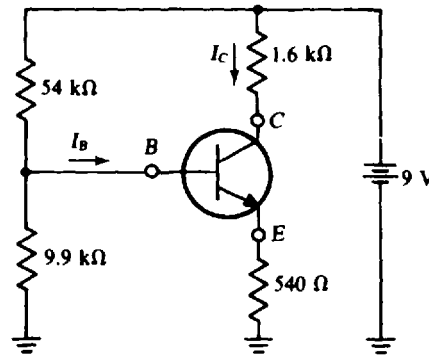

Fig. 5-11

One way to find the base current is to break the circuit at the base lead and determine the Thévenin equivalent of the bias circuit. For this approach it helps to consider the 9-V source to be two 9-V sources, one of which is connected to the 1.6-k Ω collector resistor and the other of which is connected to the 54-k Ω bias resistor. Then the bias circuit appears as illustrated in Fig. 5-12a. From it, the voltage V_{Th} is, by voltage division,

$$V_{Th} = \frac{9.9}{9.9 + 54} \times 9 = 1.394 \text{ V}$$

Replacing the 9-V source by a short circuit places the 54- and 9.9-k Ω resistors in parallel for an R_{Th} of

$$R_{Th} = \frac{9.9 \times 54}{9.9 + 54} = 8.37 \text{ k}\Omega$$

and the circuit simplifies to that shown in Fig. 5-12b.

From KVL applied to the base loop, and from the fact that $I_C + I_B = 31I_B$ flows through the 540- Ω emitter resistor,

$$1.394 = 8.37I_B + 0.7 + 0.54 \times 31I_B$$

from which

$$I_B = \frac{0.694}{25.1} = 0.0277 \text{ mA} = 27.7 \mu\text{A}$$

Of course, the simplifying kilohm-milliampere method was used in some of the calculations.

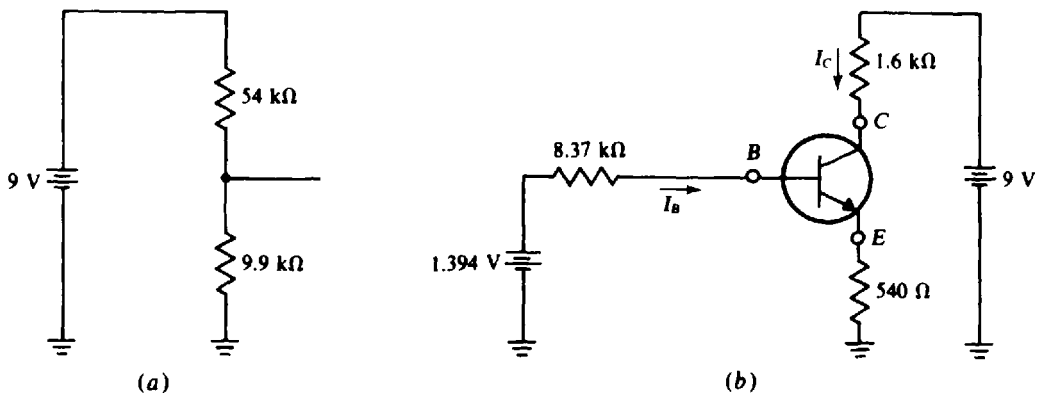

Fig. 5-12

5.7 Find the Thévenin equivalent circuit at terminals *a* and *b* of the circuit with transistor model shown in Fig. 5-13.

The open-circuit voltage is $500 \times 30I_B = 15\,000I_B$, positive at terminal *b*. From the base circuit, $I_B = 10/1000 \text{ A} = 10 \text{ mA}$. Substituting in for I_B gives

$$V_{Th} = 15\,000(10 \times 10^{-3}) = 150 \text{ V}$$

The best way to find R_{Th} is to deactivate the independent 10-V source and determine the resistance at terminals *a* and *b*. With this source deactivated, $I_B = 0 \text{ A}$, and so $30I_B = 0 \text{ A}$, which means that the dependent current source acts as an open circuit—it produces zero current regardless of the voltage across it. The result is that the resistance at terminals *a* and *b* is just the shown 500 Ω.

The Thévenin equivalent circuit is a 500-Ω resistor in series with a 150-V source that has its positive terminal toward terminal *b*, as shown in Fig. 5-14.

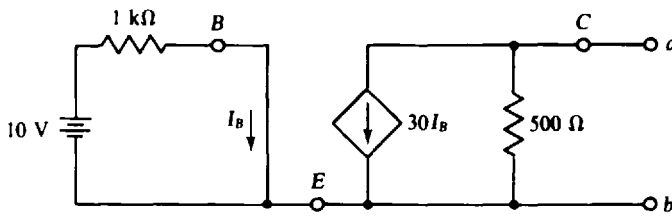

Fig. 5-13

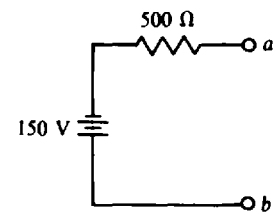

Fig. 5-14

5.8 What is the Norton equivalent circuit for the transistor circuit shown in Fig. 5-15?

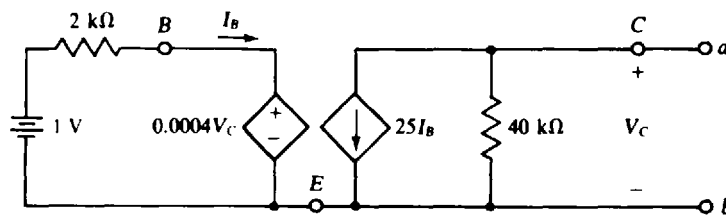

Fig. 5-15

A good approach is to first find I_{SC} , which is the Norton current I_N ; next find V_{OC} , which is the Thévenin voltage V_{Th} ; and then take their ratio to obtain the Norton resistance R_N , which is the same as R_{Th} .

Placing a short circuit across terminals *a* and *b* makes $V_C = 0 \text{ V}$, which in turn causes the dependent voltage source in the base circuit to be a short circuit. As a result, $I_B = 1/2000 \text{ A} = 0.5 \text{ mA}$. This short circuit also places 0 V across the 40-kΩ resistor, preventing any current flow through it. So, all the $25I_B = 25 \times 0.5 = 12.5 \text{ mA}$ current from the dependent current source flows through the short circuit in a direction from terminal *b* to terminal *a*: $I_{SC} = I_N = 12.5 \text{ mA}$.

The open-circuit voltage is more difficult to find. From the collector circuit, $V_C = (-25I_B)(40\,000) = -10^6 I_B$. This substituted into the KVL equation for the base circuit produces an equation in which I_B is the only unknown:

$$1 = 2000I_B + 0.0004V_C = 2000I_B + 0.0004(-10^6 I_B) = 1600I_B$$

So, $I_B = 1/1600 \text{ A} = 0.625 \text{ mA}$, and $V_C = -10^6 I_B = -10^6(0.625 \times 10^{-3}) = -625 \text{ V}$. The result is that $V_{OC} = 625 \text{ V}$, positive at terminal *b*.

In the calculation of R_N , signs are important when, as here, a circuit has dependent sources that can cause R_N to be negative. From Fig. 5-3b, $R_{Th} = R_N$ is the ratio of the open-circuit voltage referenced positive

at terminal a and the short-circuit current referenced from terminal a to terminal b . Alternatively, both references can be reversed, which is convenient here. So,

$$R_N = \frac{V_{OC}}{I_{SC}} = \frac{625}{12.5 \times 10^{-3}} = 50 \text{ k}\Omega$$

The Norton equivalent circuit is a 50-k Ω resistor in parallel with a 12.5-mA current source that is directed toward terminal b , as shown in Fig. 5-16.

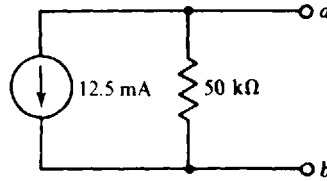

Fig. 5-16

5.9 Directly find the output resistance of the circuit shown in Fig. 5-15.

Figure 5-17 shows the circuit with the 1-V independent source deactivated and a 1-A current source applied at the output a and b terminals. From Ohm's law applied to the base circuit,

$$I_B = -\frac{0.0004V_C}{2000} = -2 \times 10^{-7}V_C$$

Nodal analysis applied to the top node of the collector circuit gives

$$\frac{V_C}{40\,000} + 25I_B = 1 \quad \text{or} \quad \frac{V_C}{40\,000} + 25(-2 \times 10^{-7}V_C) = 1$$

upon substitution for I_B . The solution is $V_C = 50\,000$ V, and so $R_{out} = R_{Th} = 50 \text{ k}\Omega$. This checks with the $R_N = R_{Th}$ answer from the Prob. 5.8 solution in which the $R_N = R_{Th} = V_{OC}/I_{SC}$ approach was used.

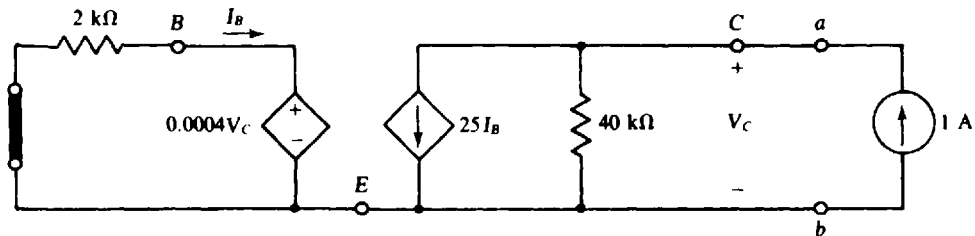

Fig. 5-17

5.10 Find the Thévenin equivalent of the circuit shown in Fig. 5-18.

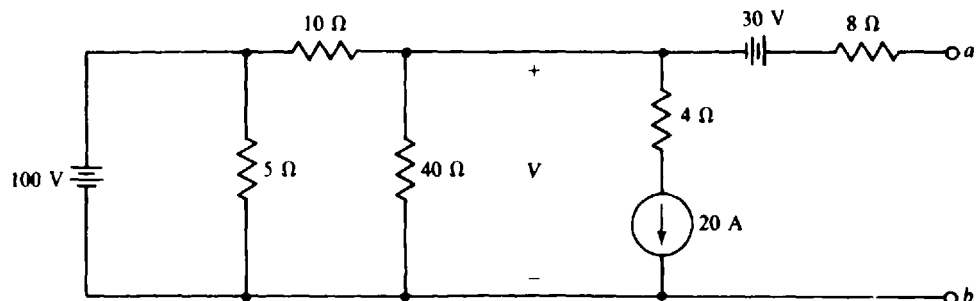

Fig. 5-18

The Thévenin or open-circuit voltage, positive at terminal *a*, is the indicated *V* plus the 30 V of the 30-V source. The 8-Ω resistor has no effect on this voltage because there is zero current flow through it as a result of the open circuit. With zero current there is zero voltage. *V* can be found from a single nodal equation:

$$\frac{V - 100}{10} + \frac{V}{40} + 20 = 0$$

Multiplying by 40 and simplifying produces

$$5V = 400 - 800 \quad \text{from which} \quad V = -80 \text{ V}$$

So, $V_{Th} = -80 + 30 = -50 \text{ V}$. Notice that the 5-Ω and 4-Ω resistors have no effect on V_{Th} .

Figure 5-19*a* shows the circuit with the voltage sources replaced by short circuits and the current source by an open circuit. Notice that the 5-Ω resistor has no effect on R_{Th} because it is shorted, and neither does the 4-Ω resistor because it is in series with an open circuit. Since the resistor arrangement in Fig. 5-19*a* is series-parallel, R_{Th} is easy to calculate by combining resistances: $R_{Th} = 8 + 40 \parallel 10 = 16 \text{ } \Omega$.

Figure 5-19*b* shows the Thévenin equivalent circuit.

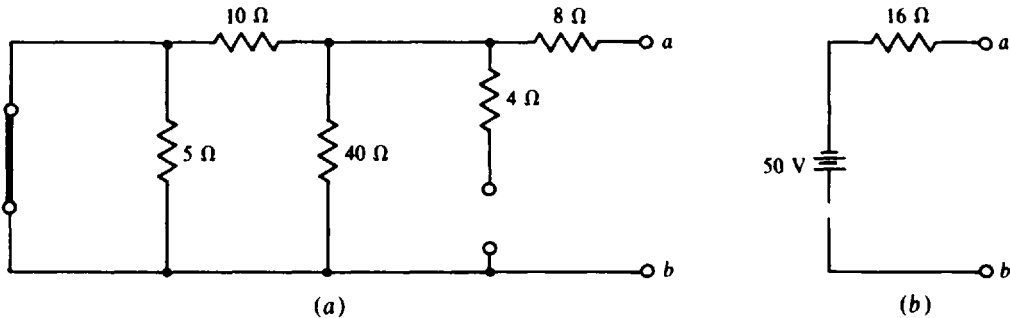

Fig. 5-19

The fact that neither the 5-Ω nor the 4-Ω resistor has an effect on V_{Th} and R_{Th} leads to the generalization that resistors in parallel with ideal voltage sources, and resistors in series with ideal current sources, have no effect on voltages and currents elsewhere in a circuit.

5.11 Obtain the Thévenin equivalent of the circuit of Fig. 5-20*a*.

By inspection, $V_{Th} = 0 \text{ V}$ because the circuit does not contain any independent sources. For a determination of R_{Th} , it is necessary to apply a source and calculate the ratio of the source voltage to the source current. Any independent source can be applied, but often a particular one is best. Here, if a 12-V voltage source is applied positive at terminal *a*, as shown in Fig. 5-20*b*, then $I = 12/12 = 1 \text{ A}$, which is the most convenient current. As a result, the dependent source provides a voltage of $8I = 8 \text{ V}$. So, by KCL,

$$I_s = \frac{12}{12} + \frac{12}{6} + \frac{12 - 8}{4} = 4 \text{ A}$$

Finally,
$$R_{Th} = \frac{V_s}{I_s} = \frac{12}{4} = 3 \text{ } \Omega$$

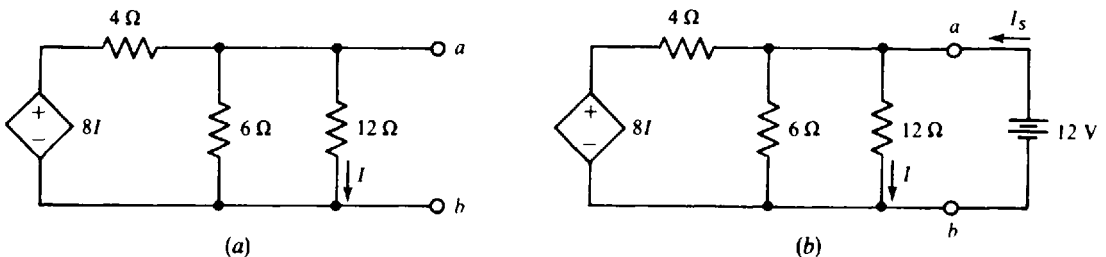

Fig. 5-20

- 5.12 For the circuit of Fig. 5-21, obtain the Thévenin equivalent to the left of the a - b terminals. Then use this equivalent in determining I .

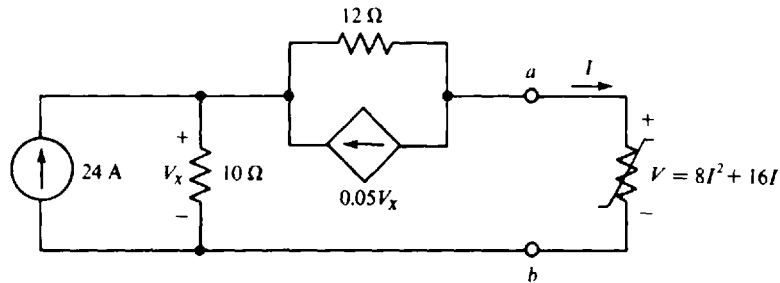

Fig. 5-21

The Thévenin equivalent can be obtained by determining any two of V_{Th} , R_{Th} , and I_{Sc} . By inspection, it appears that the two easiest to determine are V_{Th} and R_{Th} .

If the circuit is opened at the a - b terminals, all 24 A of the independent current source must flow through the 10- Ω resistor, making $V_x = 10(24) = 240$ V. Consequently, the dependent current source provides a current of $0.05V_x = 0.05(240) = 12$ A, all of which must flow through the 12- Ω resistor. As a result, by KVL,

$$V_{Th} = V_{ab} = -12(12) + 240 = 96 \text{ V}$$

Because of the presence of the dependent source, R_{Th} must be found by applying a source and determining the ratio of the source voltage to the source current. The preferable source to apply is a current source, as shown in Fig. 5-22a. If this source is 1 A, then $V_x = 10(1) = 10$ V, and consequently the dependent current source provides a current of $0.05(10) = 0.5$ A. Since this is one-half the source current, the other half must flow through the 12- Ω resistor. And so, by KVL,

$$V_s = 0.5(12) + 1(10) = 16 \text{ V}$$

Then,

$$R_{Th} = \frac{V_s}{I_s} = \frac{16}{1} = 16 \Omega$$

Figure 5-22b shows the Thévenin equivalent connected to the nonlinear load of the original circuit. The current I is much easier to calculate with this circuit. By KVL,

$$16I + 8I^2 + 16I = 96 \quad \text{or} \quad I^2 + 4I - 12 = 0$$

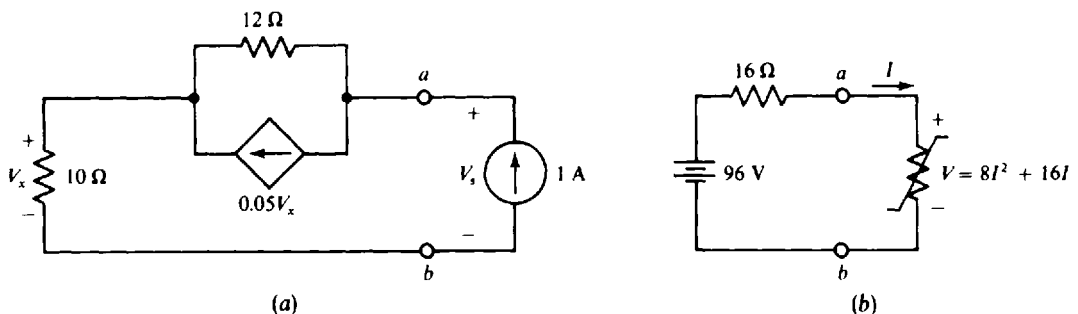

Fig. 5-22

Applying the quadratic formula gives

$$I = \frac{-4 \pm \sqrt{16 + 48}}{2} = \frac{-4 \pm 8}{2} = 2 \text{ A} \quad \text{or} \quad -6 \text{ A}$$

Only the 2-A current is physically possible because current must flow out of the positive terminal of the Thévenin voltage source, which means that I must be positive. So, $I = 2$ A.

5.13 Figure 5-23a shows an emitter-follower circuit for obtaining a low output resistance for resistance matching. Find R_{out} .

Because the circuit has a dependent source but no independent sources, R_{out} must be found by applying a source at the output terminals, preferably a 1-A current source as shown in Fig. 5-23b.

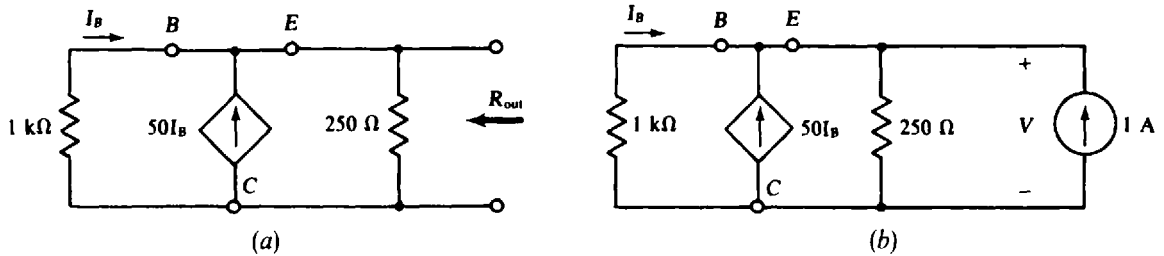

Fig. 5-23

From KCL applied at the top node,

$$\frac{V}{1000} - 50I_B + \frac{V}{250} = 1$$

But from Ohm's law applied to the 1-kΩ resistor, $I_B = -V/1000$. With this substitution the equation becomes

$$\frac{V}{1000} - 50\left(-\frac{V}{1000}\right) + \frac{V}{250} = 1$$

from which $V = 18.2$ V. Then $R_{out} = V/1 = 18.2 \Omega$, which is much smaller than the resistance of either resistor in the circuit.

5.14 Find the input resistance R_{in} of the circuit shown in Fig. 5-24.

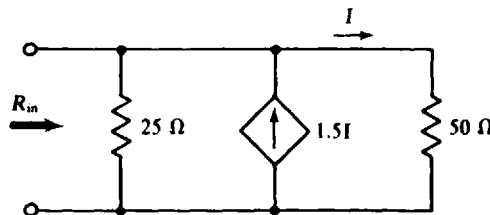

Fig. 5-24

Since this circuit has a dependent source but no independent sources, the approach to finding the input resistance is to apply a source at the input. Then the input resistance is equal to the input voltage divided by the input current. A good source to apply is a 1-A current, as shown in Fig. 5-25.

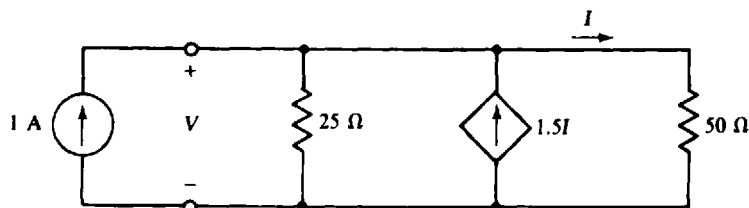

Fig. 5-25

By nodal analysis,

$$\frac{V}{25} - 1.5I + \frac{V}{50} = 1$$

But from the right-hand branch, $I = V/50$. With this substitution the equation becomes

$$\frac{V}{25} - 1.5 \frac{V}{50} + \frac{V}{50} = 1$$

the solution to which is $V = 33.3$ V. So, the input resistance is

$$R_{in} = \frac{V}{I} = \frac{33.3}{1} = 33.3 \Omega$$

- 5.15** Find the input resistance of the circuit shown in Fig. 5-24 if the dependent current source has a current of $5I$ instead of $1.5I$.

For a 1-A current source applied at the input terminals, the nodal equation at the top node is

$$\frac{V}{25} - 5I + \frac{V}{50} = 1$$

But, from the right-hand branch, $I = V/50$. With this substitution the equation is

$$\frac{V}{25} - 5 \frac{V}{50} + \frac{V}{50} = 1$$

from which $V = -25$ V. Thus, the input resistance is $R_{in} = -25/1 = -25 \Omega$.

A negative resistance may be somewhat disturbing to the mind when first encountered, but it is physically real even though it takes a transistor circuit, an operational amplifier, or the like to obtain it. Physically, a negative input resistance means that the circuit supplies power to whatever source is applied at the input, with the dependent source being the source of power.

- 5.16** Figure 5-26a shows an emitter-follower circuit for obtaining a large input resistance for resistance matching. The load is a $30\text{-}\Omega$ resistor, as shown. Find the input resistance R_{in} .

Because the circuit has a dependent source and no independent sources, the preferable way to find R_{in} is from the input voltage when a 1-A current source is applied, as shown in Fig. 5-26b. Here, $I_B = 1$ A, and so the total current to the parallel resistors is $I_B + 100I_B = 101I_B = 101$ A, and the voltage V is

$$V = 101(250 \parallel 30) \text{ V} = 2.7 \text{ kV}$$

The input resistance is $R_{in} = V/1 = 2.7 \text{ k}\Omega$, which is much greater than the 30Ω of the load.

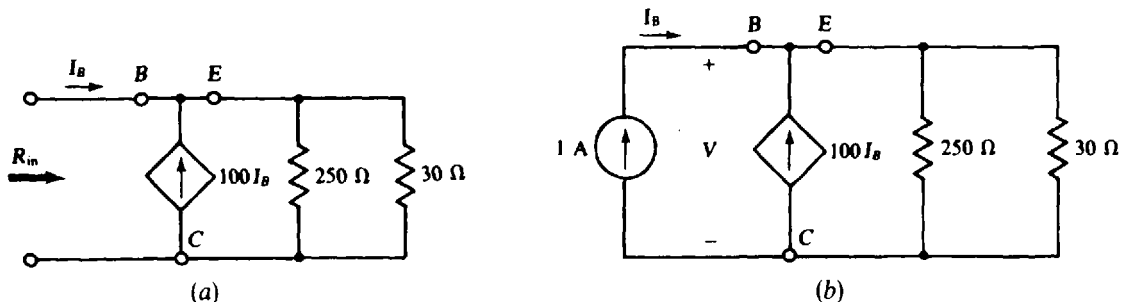

Fig. 5-26

5.17 What is the maximum power that can be drawn from a 12-V battery that has an internal resistance of 0.25Ω ?

A resistive load of 0.25Ω draws maximum power because it has the same resistance as the Thévenin or internal resistance of the source. For this load, half the source voltage drops across the load, making the power $6^2/0.25 = 144 \text{ W}$.

5.18 What is the maximum power that can be drawn by a resistor connected to terminals a and b of the circuit shown in Fig. 5-15?

In the solution to Prob. 5.8, the Thévenin resistance of the circuit shown in Fig. 5-15 was found to be $50 \text{ k}\Omega$ and the Norton current was found to be 12.5 mA . So, a load resistor of $50 \text{ k}\Omega$ absorbs maximum power. By current division, half the Norton current flows through it, producing a power of

$$\left(\frac{12.5}{2} \times 10^{-3}\right)^2 (50 \times 10^3) = 1.95 \text{ W}$$

5.19 In the circuit of Fig. 5-27, what resistor R_L will absorb maximum power and what is this power?

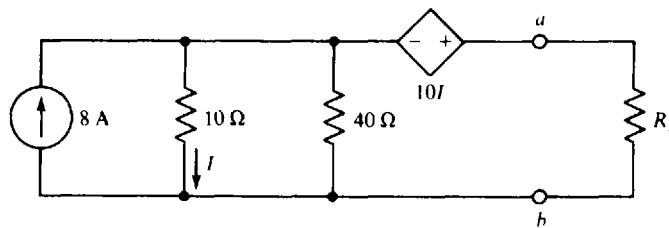

Fig. 5-27

For maximum power transfer, $R_L = R_{Th}$ and $P_{max} = V_{Th}^2 / (4R_{Th})$. So, it is necessary to obtain the Thévenin equivalent of the portion of the circuit to the left of the a and b terminals.

If R_L is replaced by an open circuit, then the current I is, by current division,

$$I = \frac{40}{40 + 10} \times 8 = 6.4 \text{ A}$$

Consequently, the dependent voltage source provides a voltage of $10(6.4) = 64 \text{ V}$. Then, by KVL,

$$V_{ab} = V_{Th} = 64 + 10(6.4) = 128 \text{ V}$$

It is convenient to use the short-circuit current approach in determining R_{Th} . If a short circuit is placed across terminals a and b , all components of the circuit of Fig. 5-27 are in parallel. Consequently, the voltage drop, top to bottom, across the $10\text{-}\Omega$ resistor of $10I$ is equal to the $-10I$ voltage drop across the dependent voltage source. Since the solution to $10I = -10I$ is $I = 0 \text{ A}$, there is a zero voltage drop across both resistors, which means that all the 8 A of the current source must flow down through the short circuit. So, $I_{sc} = 8 \text{ A}$ and

$$R_{Th} = \frac{V_{Th}}{I_{sc}} = \frac{128}{8} = 16 \Omega$$

Thus, $R_L = 16 \Omega$ for maximum power absorption. Finally, this power is

$$P_{max} = \frac{V_{Th}^2}{4R_{Th}} = \frac{128^2}{4(16)} = 256 \text{ W}$$

5.20 In the circuit of Fig. 5-28, what resistor R_L will absorb maximum power and what is this power?

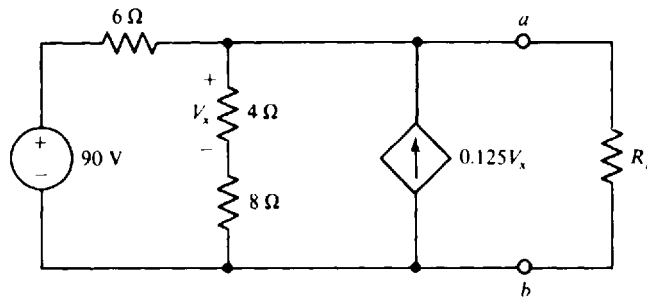

Fig. 5-28

It is, of course, necessary to obtain the Thévenin equivalent to the left of the a and b terminals. The Thévenin voltage V_{Th} will be obtained first. Observe that the voltage drop across the $4\text{-}\Omega$ resistor is V_x , and that this resistor is in series with an $8\text{-}\Omega$ resistor. Consequently, by voltage division performed in a reverse manner, the open-circuit voltage is $V_{Th} = V_{ab} = 3V_x$. Next, with R_L removed, applying KCL at the node that includes terminal a gives

$$\frac{3V_x - 90}{6} + \frac{V_x}{4} - 0.125V_x = 0$$

the solution to which is $V_x = 24$ V. So, $V_{Th} = 3V_x = 3(24) = 72$ V.

By inspection of the circuit, it should be fairly apparent that it is easier to use I_{sc} to obtain R_{Th} than it is to determine R_{Th} directly. If a short circuit is placed across terminals a and b , then $V_x = 0$ V, and so no current flows in the $4\text{-}\Omega$ resistor and there is no current flow in the dependent current source. Consequently, $I_{sc} = 90/6 = 15$ A. Then,

$$R_{Th} = \frac{V_{Th}}{I_{sc}} = \frac{72}{15} = 4.8 \text{ }\Omega$$

which is the resistance that R_L should have for maximum power absorption. Finally,

$$P_{max} = \frac{V_{Th}^2}{4R_{Th}} = \frac{72^2}{4(4.8)} = 270 \text{ W}$$

5.21 Use superposition to find the power absorbed by the $12\text{-}\Omega$ resistor in the circuit shown in Fig. 5-29.

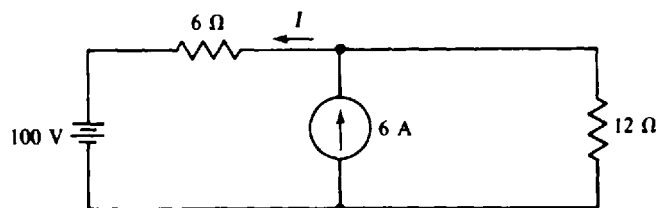

Fig. 5-29

Superposition cannot be used to find power in a dc circuit because the method applies only to linear quantities, and power has a squared voltage or current relation instead of a linear one. To illustrate, the current through the $12\text{-}\Omega$ resistor from the 100-V source is, with the 6-A source replaced by an open circuit, $100/(12 + 6) = 5.556$ A. The corresponding power is $5.556^2 \times 12 = 370$ W. With the voltage source replaced by a short circuit, the current through the $12\text{-}\Omega$ resistor from the 6-A current source is, by current division, $[6/(12 + 6)](6) = 2$ A. The corresponding power is $2^2 \times 12 = 48$ W. So, if superposition could be applied to power, the result would be $370 + 48 = 418$ W for the power dissipated in the $12\text{-}\Omega$ resistor.

Superposition does, however, apply to currents. So, the total current through the 12-Ω resistor is $5.556 + 2 = 7.556$ A, and the power consumed is $7.556^2 \times 12 = 685$ W, which is much different than the 418 W found by erroneously applying superposition to power.

5.22 In the circuit shown in Fig. 5-29, change the 100-V source to a 360-V source, and the 6-A current source to an 18-A source, and use superposition to find the current I .

Figure 5-30a shows the circuit with the current source replaced by an open circuit. Obviously, the component I_V of I from the voltage source is $I_V = -360/(6 + 12) = -20$ A. Figure 5-30b shows the circuit with the voltage source replaced by a short circuit. By current division, I_C , the current-source component of I , is $I_C = [12/(12 + 6)](18) = 12$ A. The total current is the algebraic sum of the current components: $I = I_V + I_C = -20 + 12 = -8$ A.

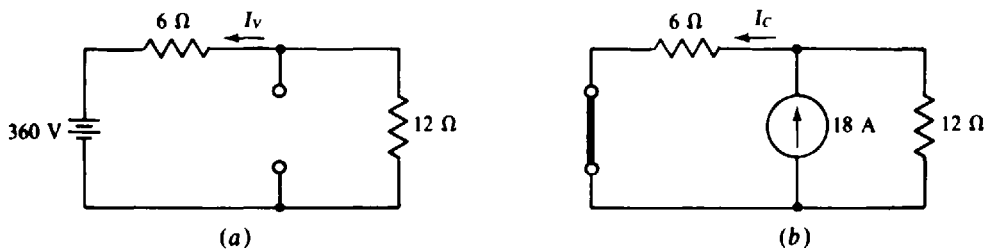

Fig. 5-30

5.23 For the circuit shown in Fig. 5-18, use superposition to find V_{Th} referenced positive on terminal a .

Clearly, the 30-V source contributes 30 V to V_{Th} because this source, being in series with an open circuit, cannot cause any currents to flow. Zero currents mean zero resistor voltage drops, and so the only voltage in the circuit is that of the source.

Figure 5-31a shows the circuit with all independent sources deactivated except the 100-V source. Notice that the voltage across the 40-Ω resistor appears across terminals a and b because there is a zero voltage drop across the 8-Ω resistor. By voltage division this component of V_{Th} is

$$V_{Thv} = \frac{40}{40 + 10} \times 100 = 80 \text{ V}$$

Figure 5-31b shows the circuit with the current source as the only independent source. The voltage across the 40-Ω resistor is the open-circuit voltage since there is a zero voltage drop across the 8-Ω resistor. Note that the short circuit replacing the 100-V source prevents the 5-Ω resistor from having an effect, and also it places the 40- and 10-Ω resistors in parallel for a net resistance of $40 \parallel 10 = 8 \Omega$. So, the component of V_{Th} from the current source is $V_{Thc} = -20 \times 8 = -160$ V.

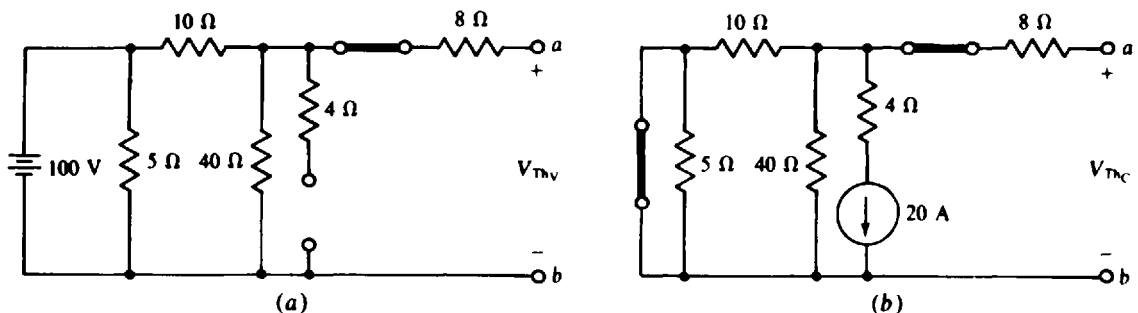

Fig. 5-31

V_{Th} is the algebraic sum of the three components of voltage:

$$V_{Th} = 30 + 80 - 160 = -50 \text{ V}$$

Notice that finding V_{Th} by superposition requires more work than finding it by nodal analysis, as was done in the solution to Prob. 5.10.

5.24 Use superposition to find V_{Th} for the circuit shown in Fig. 5-15.

Although this circuit has three sources, superposition cannot be used since two of the sources are dependent. Only one source is independent. The superposition theorem does not apply to dependent sources.

5.25 Use Millman's theorem to find the current flowing to a $0.2\text{-}\Omega$ resistor from four batteries operating in parallel. Each battery has a 12.8-V open-circuit voltage. The internal resistances are 0.1 , 0.12 , 0.2 , and $0.25 \text{ }\Omega$.

Because the battery voltages are the same, being 12.8 V , the Millman voltage is $V_M = 12.8 \text{ V}$. The Millman resistance is the inverse of the sum of the conductances:

$$R_M = \frac{1}{1/0.1 + 1/0.12 + 1/0.2 + 1/0.25} \text{ }\Omega = 36.6 \text{ m}\Omega$$

Of course, the resistor current equals the Millman voltage divided by the sum of the Millman and load resistances:

$$I = \frac{V_M}{R_M + R} = \frac{12.8}{0.2 + 0.0366} = 54.1 \text{ A}$$

5.26 Use Millman's theorem to find the current drawn by a $5\text{-}\Omega$ resistor from four batteries operating in parallel. The battery open-circuit voltages and internal resistances are 18 V and $1 \text{ }\Omega$, 20 V and $2 \text{ }\Omega$, 22 V and $5 \text{ }\Omega$, and 24 V and $4 \text{ }\Omega$.

The Millman voltage and resistance are

$$V_M = \frac{(1)(18) + (1/2)(20) + (1/5)(22) + (1/4)(24)}{1 + 1/2 + 1/5 + 1/4} = 19.7 \text{ V}$$

$$R_M = \frac{1}{1 + 1/2 + 1/5 + 1/4} = 0.513 \text{ }\Omega$$

The current is, of course, the Millman voltage divided by the sum of the Millman and load resistances:

$$I = \frac{V_M}{R_M + R} = \frac{19.7}{0.513 + 5} = 3.57 \text{ A}$$

5.27 Use Millman's theorem to find I for the circuit shown in Fig. 5-32.

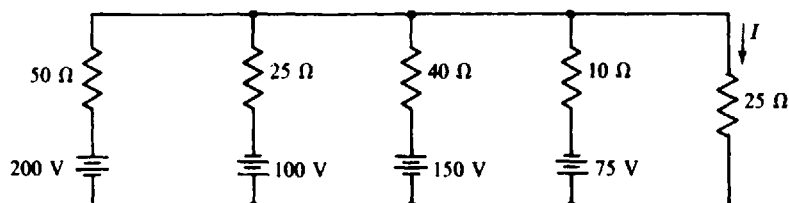

Fig. 5-32

The Millman voltage and resistance are

$$V_M = \frac{(1/50)(200) + (1/25)(-100) + (1/40)(150) + (1/10)(-75)}{1/50 + 1/25 + 1/40 + 1/10} = -20.27 \text{ V}$$

$$R_M = \frac{1}{1/50 + 1/25 + 1/40 + 1/10} = 5.41 \text{ } \Omega$$

And so

$$I = \frac{V_M}{R_M + R} = \frac{-20.27}{5.41 + 25} = -0.667 \text{ A}$$

5.28 Transform the Δ shown in Fig. 5-33a to the Y shown in Fig. 5-33b for (a) $R_1 = R_2 = R_3 = 36 \text{ } \Omega$, and (b) $R_1 = 20 \text{ } \Omega$, $R_2 = 30 \text{ } \Omega$, and $R_3 = 50 \text{ } \Omega$.

(a) For Δ resistances of the same value, $R_Y = R_\Delta/3$. So, here, $R_A = R_B = R_C = 36/3 = 12 \text{ } \Omega$.

(b) The denominators of the R_Y formulas are the same: $R_1 + R_2 + R_3 = 20 + 30 + 50 = 100 \text{ } \Omega$. The numerators are products of the adjacent resistor resistances if the Y is placed inside the Δ :

$$R_A = \frac{R_1 R_2}{100} = \frac{20 \times 30}{100} = 6 \text{ } \Omega \quad R_B = \frac{R_2 R_3}{100} = \frac{30 \times 50}{100} = 15 \text{ } \Omega \quad R_C = \frac{R_1 R_3}{100} = \frac{20 \times 50}{100} = 10 \text{ } \Omega$$

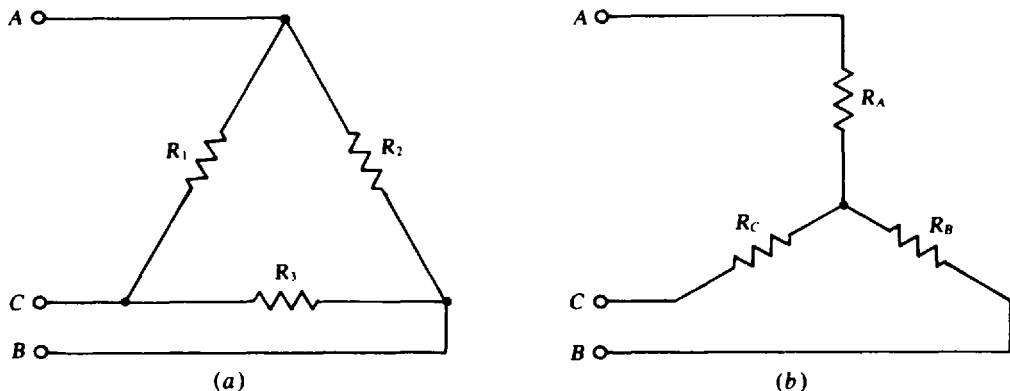

Fig. 5-33

5.29 Transform the Y shown in Fig. 5-33b to the Δ shown in Fig. 5-33a for (a) $R_A = R_B = R_C = 5 \text{ } \Omega$, and (b) $R_A = 10 \text{ } \Omega$, $R_B = 5 \text{ } \Omega$, $R_C = 20 \text{ } \Omega$.

(a) For Y resistances of the same value: $R_\Delta = 3R_Y$. So, here, $R_1 = R_2 = R_3 = 3 \times 5 = 15 \text{ } \Omega$.

(b) The numerators of the R_Δ formulas are the same: $R_A R_B + R_A R_C + R_B R_C = 10 \times 5 + 10 \times 20 + 5 \times 20 = 350$. The denominators of the R_Δ formulas are the resistances of the Y arms opposite the Δ arms if the Y is placed inside the Δ . Thus,

$$R_1 = \frac{350}{R_B} = \frac{350}{5} = 70 \text{ } \Omega \quad R_2 = \frac{350}{R_C} = \frac{350}{20} = 17.5 \text{ } \Omega \quad R_3 = \frac{350}{R_A} = \frac{350}{10} = 35 \text{ } \Omega$$

5.30 Use a Δ -to-Y transformation in finding the currents I_1 , I_2 , and I_3 for the circuit shown in Fig. 5-34.

The Δ of 15- Ω resistors transforms to a Y of $15/3 = 5\text{-}\Omega$ resistors that are in parallel with the Y of 20- Ω resistors. It is not obvious that they are in parallel, and in fact they would not be if the resistances for each Y were not all the same value. When, as here, they are the same value, an analysis would show that the middle nodes are at the same potential, just as if a wire were connected between them. So, corresponding

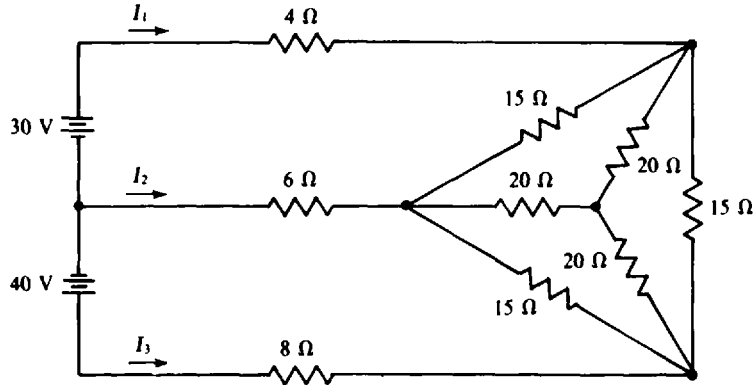

Fig. 5-34

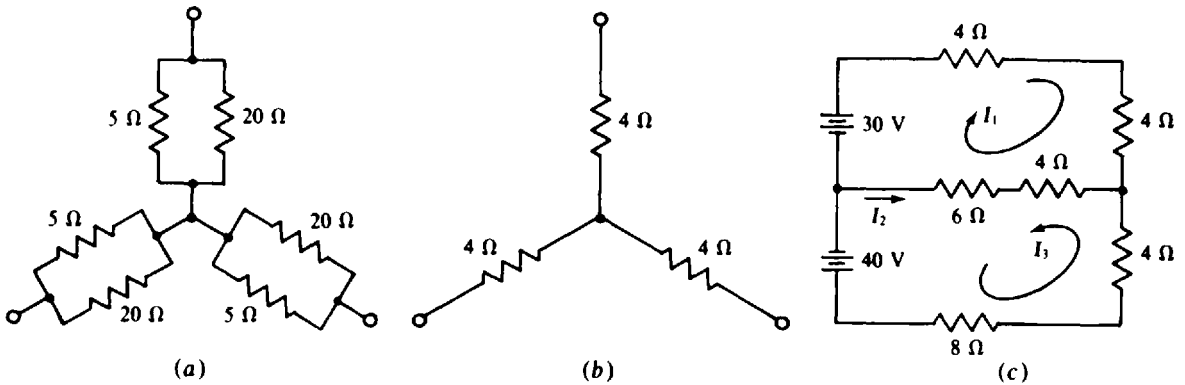

Fig. 5-35

resistors of the two Y's are in parallel, as shown in Fig. 5-35a. The two Y's can be reduced to the single Y shown in Fig. 5-35b, in which each Y resistance is $5 \parallel 20 = 4 \Omega$. With this Y replacing the Δ -Y combination, the circuit is as shown in Fig. 5-35c.

With the consideration of I_1 and I_3 as loop currents, the corresponding KVL equations are

$$30 = 18I_1 + 10I_3 \quad \text{and} \quad 40 = 10I_1 + 22I_3$$

the solutions to which are $I_1 = 0.88 \text{ A}$ and $I_3 = 1.42 \text{ A}$. Then, from KCL applied at the right-hand node, $I_2 = -I_1 - I_3 = -2.3 \text{ A}$.

5.31 Using a Y-to- Δ transformation, find the total resistance R_T of the circuit shown in Fig. 5-36, which has a bridged-T attenuator.

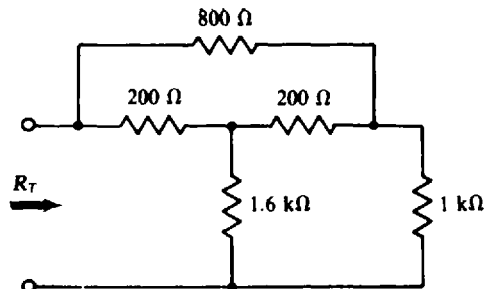

Fig. 5-36

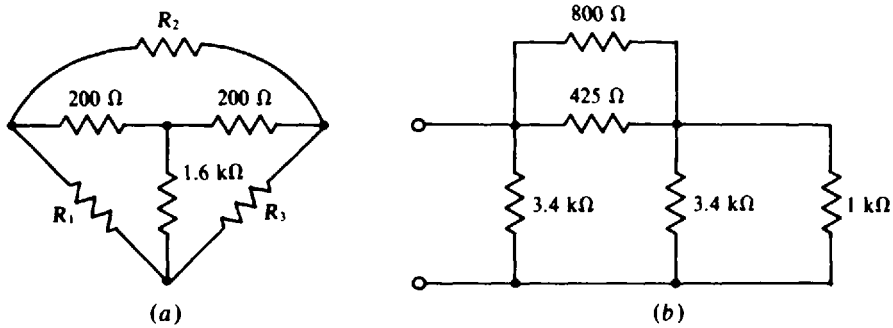

Fig. 5-37

Figure 5-37a shows the T part of the circuit inside a Δ as an aid in finding the Δ resistances. From the Y-to- Δ transformation formulas,

$$R_1 = R_3 = \frac{200(200) + 200(1600) + 200(1600)}{200} = \frac{680\,000}{200} \Omega = 3.4\text{ k}\Omega$$

$$R_2 = \frac{680\,000}{1600} = 425\ \Omega$$

As a result of this transformation, the circuit becomes series-parallel as shown in Fig. 5-37b, and the total resistance is easy to find:

$$R_T = 3400 \parallel (800 \parallel 425 + 3400 \parallel 1000) = 3400 \parallel 1050 = 802\ \Omega$$

5.32 Find I for the circuit shown in Fig. 5-38 by using a Δ -Y transformation.

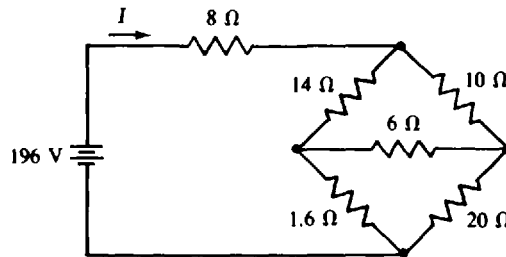

Fig. 5-38

The bridge simplifies to a series-parallel configuration from a transformation of either the top or bottom Δ to a Y, or the left- or right-hand Y to a Δ . Perhaps the most common approach is to transform one of the Δ 's to a Y, although the work required is about the same for any type of transformation. Figure 5-39a shows the top Δ enclosing a Y as a memory aid for the transformation of this Δ to a Y. All three Y formulas have the same denominator: $14 + 10 + 6 = 30$. The numerators, though, are the products of the resistances of the adjacent Δ resistors:

$$R_A = \frac{10 \times 14}{30} = 4.67\ \Omega \quad R_B = \frac{14 \times 6}{30} = 2.8\ \Omega \quad R_C = \frac{6 \times 10}{30} = 2\ \Omega$$

With this transformation the circuit simplifies to that shown in Fig. 5-39b in which all the resistors are in series-parallel. From it,

$$I = \frac{196}{8 + 4.67 + (2.8 + 1.6) \parallel (2 + 20)} = 12\text{ A}$$

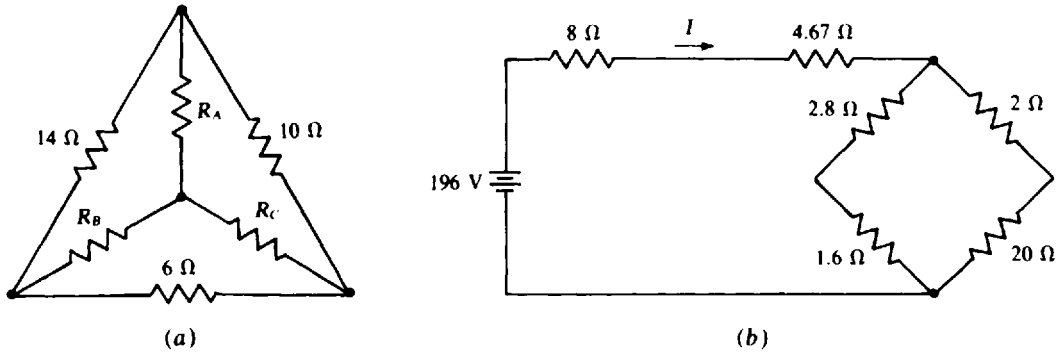

Fig. 5-39

5.33 In the circuit shown in Fig. 5-38, what resistor R replacing the 20-Ω resistor causes the bridge to be balanced? Also, what is I then?

For balance, the product of the resistances of opposite bridge arms are equal:

$$R \times 14 = 1.6 \times 10 \quad \text{from which} \quad R = \frac{16}{14} = 1.14 \Omega$$

With the bridge in balance, the center arm can be considered as an open circuit because it carries no current. This being the case, and because the bridge is a series-parallel arrangement, the current I is

$$I = \frac{196}{8 + (14 + 1.6) \parallel (10 + 1.14)} = 13.5 \text{ A}$$

Alternatively, the center arm can be considered to be a short circuit because both ends of it are at the same potential. From this point of view,

$$I = \frac{196}{8 + 14 \parallel 10 + 1.6 \parallel 1.14} = 13.5 \text{ A}$$

which is, of course, the same.

5.34 The slide-wire bridge shown in Fig. 5-40 has a uniform resistance wire that is 1 m long. If balance occurs with the slider at 24 cm from the top, what is the resistance of R_x ?

Let R_w be the total resistance of the resistance wire. Then the resistance from the top of the wire to the slider is $(24/100)R_w = 0.24R_w$. That from the slider to the bottom of the wire is $(76/100)R_w = 0.76R_w$. So, the bridge resistances are $0.24R_w$, $0.76R_w$, 30Ω , and R_x . These inserted into the bridge balance equation give

$$R_x = \frac{0.76R_w}{0.24R_w} \times 30 = 95 \Omega$$

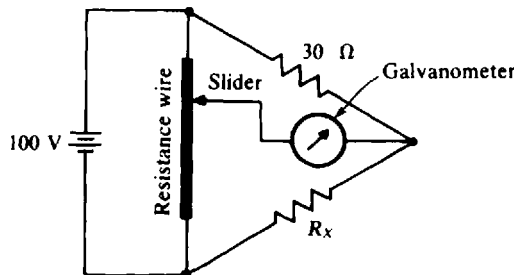

Fig. 5-40

Supplementary Problems

5.35 A car battery has a 12.1-V terminal voltage when supplying 10 A to the car lights. When the starter motor is turned over, the extra 250 A drawn drops the battery terminal voltage to 10.6 V. What is the Thévenin equivalent circuit of this battery?

Ans. 6 mΩ, 12.16 V

5.36 In full sunlight a 2- by 2-cm solar cell has a short-circuit current of 80 mA, and the current is 75 mA for a terminal voltage of 0.6 V. What is the Norton equivalent circuit?

Ans. 120 Ω, 80 mA

5.37 Find the Thévenin equivalent of the circuit shown in Fig. 5-41. Reference V_{Th} positive toward terminal a .

Ans. 12 Ω, 12 V

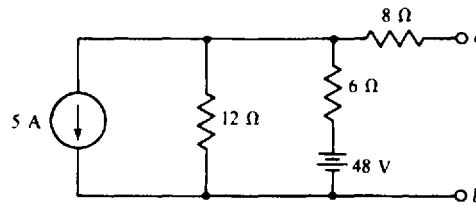

Fig. 5-41

5.38 In the circuit shown in Fig. 5-41, change the 5-A current source to a 7-A current source, the 12-Ω resistor to an 18-Ω resistor, and the 48-V source to a 96-V source. Then find the Norton equivalent circuit with the current arrow directed toward terminal a .

Ans. 12.5 Ω, 3.24 A

5.39 For the circuit shown in Fig. 5-42, find the Norton equivalent with I_N referenced positive toward terminal a .

Ans. 4 Ω, -3 A

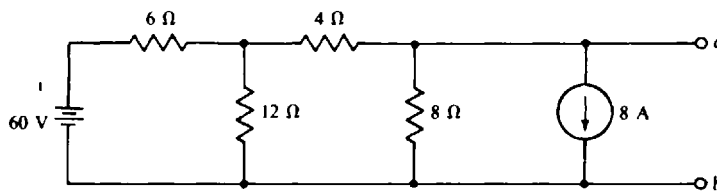

Fig. 5-42

5.40 Find the Norton equivalent of the circuit of Fig. 5-43. Reference I_N up.

Ans. 8 Ω, 8 A

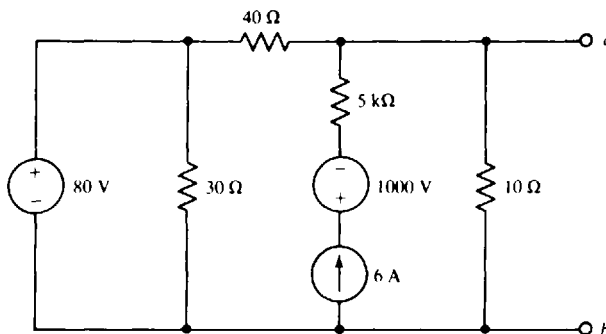

Fig. 5-43

5.41 Determine the Norton equivalent of the circuit of Fig. 5-44. Reference I_N up.

Ans. $78 \Omega, 1.84 \text{ A}$

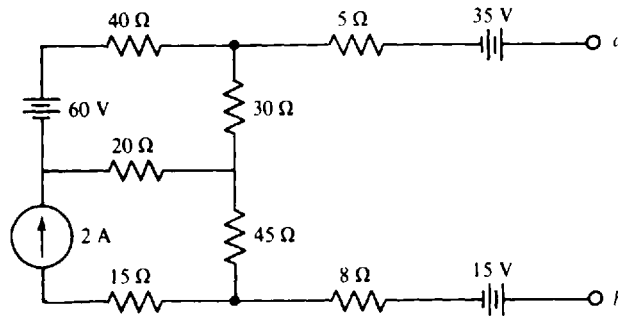

Fig. 5-44

5.42 Find the Thévenin equivalent of the grounded-base transistor circuit shown in Fig. 5-45. Reference V_{Th} positive toward terminal a .

Ans. $4 \text{ k}\Omega, 3.9 \text{ V}$

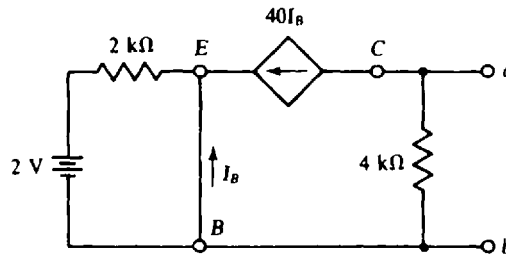

Fig. 5-45

5.43 In the transistor circuit shown in Fig. 5-46, find the base current I_B if $I_C = 40I_B$. There is a 0.7-V drop from base to emitter.

Ans. $90.1 \mu\text{A}$

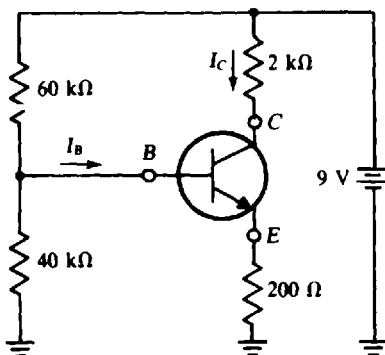

Fig. 5-46

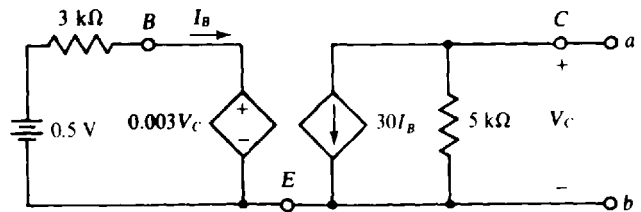

Fig. 5-47

5.44 Find the Thévenin equivalent of the transistor circuit shown in Fig. 5-47. Reference V_{Th} positive toward terminal a .

Ans. $5.88 \text{ k}\Omega, -29.4 \text{ V}$

- 5.45 Find I in the circuit shown in Fig. 5-48, which contains a nonlinear element having a V - I relation of $V = 3I^2$. Use Thévenin's theorem and the quadratic formula.

Ans. 2 A

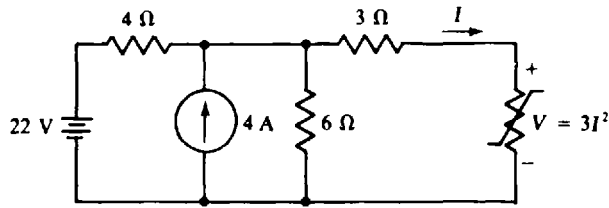

Fig. 5-48

- 5.46 Find the Thévenin equivalent of the circuit of Fig. 5-49. Reference V_{Th} positive toward terminal a .

Ans. 18.7 Ω, 26 V

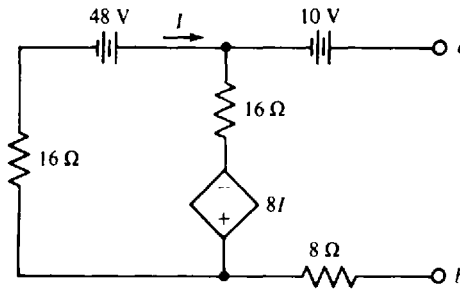

Fig. 5-49

- 5.47 Obtain the Thévenin equivalent of the circuit of Fig. 5-50.

Ans. -1.5 Ω, 0 V

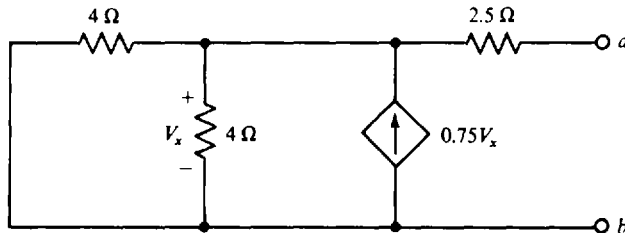

Fig. 5-50

- 5.48 Find the input resistance at terminals 1 and 1' of the transistor circuit shown in Fig. 5-51 if a 2-kΩ resistor is connected across terminals 2 and 2'.

Ans. 88.1 kΩ

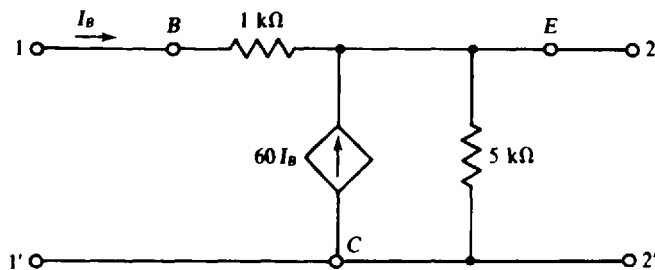

Fig. 5-51

- 5.49** Find the output resistance at terminals 2 and 2' of the transistor circuit shown in Fig. 5-51 if a source with a $1\text{-k}\Omega$ internal resistance is connected to terminals 1 and 1'. In finding the output resistance remember to replace the source by its internal resistance.

Ans. $32.6\ \Omega$

- 5.50** Find the input resistance at terminals 1 and 1' of the transistor circuit shown in Fig. 5-52 if a $5\text{-k}\Omega$ load resistor is connected between terminals 2 and 2', from collector to emitter.

Ans. $760\ \Omega$

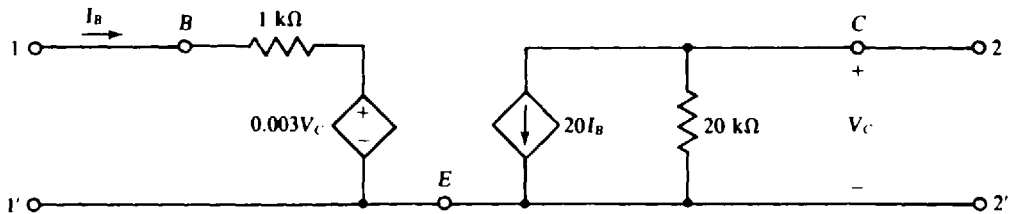

Fig. 5-52

- 5.51** Find the output resistance at terminals 2 and 2' of the transistor circuit shown in Fig. 5-52 if a source with a $500\text{-}\Omega$ internal resistance is connected to terminals 1 and 1'.

Ans. $100\ \text{k}\Omega$

- 5.52** What resistor connected between terminals a and b in the bridge circuit shown in Fig. 5-53 absorbs maximum power and what is this power?

Ans. $2.67\ \text{k}\Omega$, $4.25\ \text{mW}$

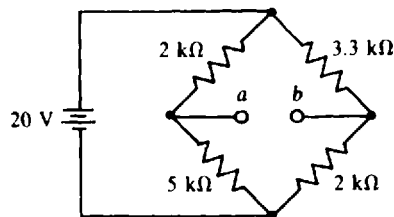

Fig. 5-53

- 5.53** What will be the reading of a zero-resistance ammeter connected across terminals a and b of the bridge circuit shown in Fig. 5-53? Assume that the ammeter is connected to have an upscale reading. What will be the reading if a $1\text{-k}\Omega$ resistor is in series with the ammeter?

Ans. $2.52\ \text{mA}$, $1.83\ \text{mA}$

- 5.54** Some solar cells are interconnected for increased power output. Each has the specifications given in Prob. 5.36. What area of solar cells is required for a power output of $1\ \text{W}$? Assume a matching load.

Ans. $20.8\ \text{cm}^2$

- 5.55** In the circuit of Fig. 5-54, what resistor R_L will absorb maximum power, and what is this power?

Ans. $3.33\ \Omega$, $480\ \text{W}$

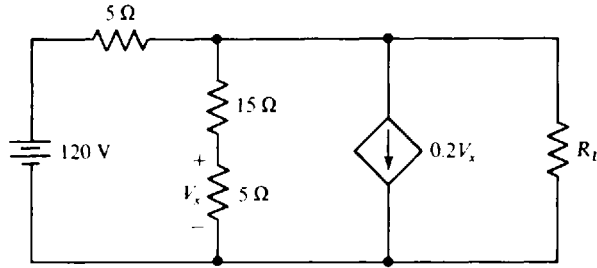

Fig. 5-54

5.56 In the circuit of Fig. 5-55, what resistor connected across terminals a and b will absorb maximum power, and what is this power?

Ans. 100 k Ω , 62.5 μ W

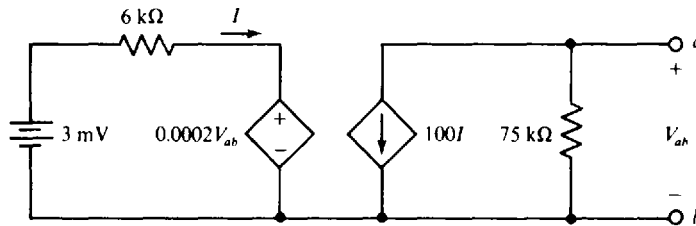

Fig. 5-55

5.57 For the circuit shown in Fig. 5-41, use superposition to find the contribution of each source to V_{Th} if it is referenced positive toward terminal a .

Ans. 32 V from the 48-V source, -20 V from the 5-A source

5.58 For the circuit shown in Fig. 5-42, use superposition to find the contribution of each source to the current in a short circuit connected between terminals a and b . The short-circuit current reference is from terminal a to terminal b .

Ans. 5 A from the 60-V source, -8 A from the 8-A source

5.59 In the circuit shown in Fig. 5-48, replace the nonlinear resistor with an open circuit and use superposition to find the contribution of each source to the open-circuit voltage referenced positive at the top.

Ans. 13.2 V from the 22-V source, 9.6 V from the 4-A source

5.60 An automobile generator operating in parallel with a battery energizes a 0.8- Ω load. The open-circuit voltages and internal resistances are 14.8 V and 0.4 Ω for the generator, and 12.8 V and 0.5 Ω for the battery. Use Millman's theorem to find the load current.

Ans. 13.6 A

5.61 For the automobile circuit of Prob. 5.60 use superposition to find the load current contribution from each source.

Ans. 8.04 A from the generator, 5.57 A from the battery

5.62 Transform the Δ shown in Fig. 5-56a to the Y in Fig. 5-56b for $R_1 = 2$ k Ω , $R_2 = 4$ k Ω , and $R_3 = 6$ k Ω .

Ans. $R_A = 667$ Ω , $R_B = 2$ k Ω , $R_C = 1$ k Ω

5.63 Repeat Prob. 5.62 for $R_1 = 8$ Ω , $R_2 = 5$ Ω , and $R_3 = 7$ Ω .

Ans. $R_A = 2$ Ω , $R_B = 1.75$ Ω , $R_C = 2.8$ Ω

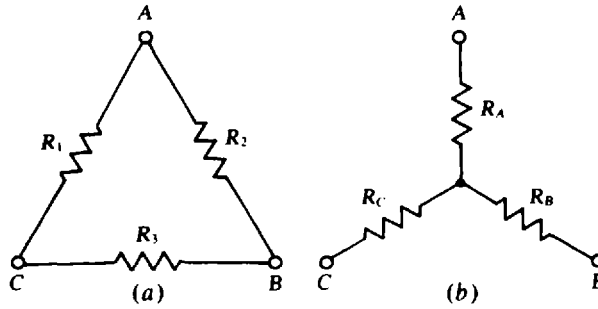

Fig. 5-56

- 5.64** Transform the Y shown in Fig. 5-56b to the Δ in Fig. 5-56a for $R_A = 12 \Omega$, $R_B = 15 \Omega$, and $R_C = 18 \Omega$.
Ans. $R_1 = 44.4 \Omega$, $R_2 = 37 \Omega$, $R_3 = 55.5 \Omega$
- 5.65** Repeat Prob. 5.64 for $R_A = 10 \text{ k}\Omega$, $R_B = 18 \text{ k}\Omega$, and $R_C = 12 \text{ k}\Omega$.
Ans. $R_1 = 28.7 \text{ k}\Omega$, $R_2 = 43 \text{ k}\Omega$, $R_3 = 51.6 \text{ k}\Omega$
- 5.66** For the lattice circuit shown in Fig. 5-57, use a Δ -Y transformation to find the V that makes $I = 3 \text{ A}$.
Ans. 177 V

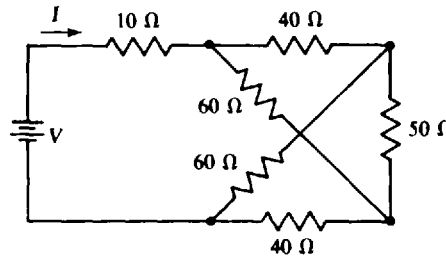

Fig. 5-57

- 5.67** Use a Δ -Y transformation to find the currents in the circuit shown in Fig. 5-58.
Ans. $I_1 = 7.72 \text{ A}$, $I_2 = -0.36 \text{ A}$, $I_3 = -7.36 \text{ A}$
- 5.68** Use a Δ -to-Y transformation in finding the voltage V that causes 2 A to flow down through the $3\text{-}\Omega$ resistor in the circuit shown in Fig. 5-59.
Ans. 17.8 V

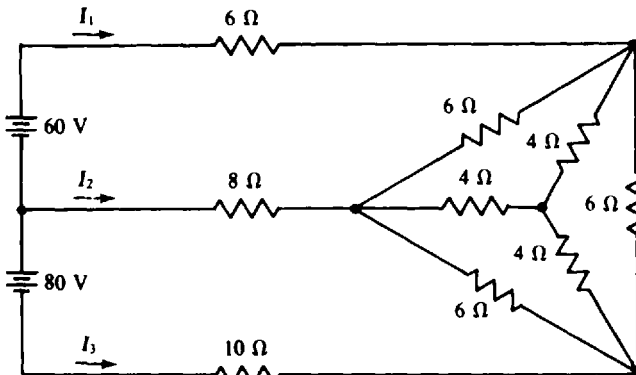

Fig. 5-58

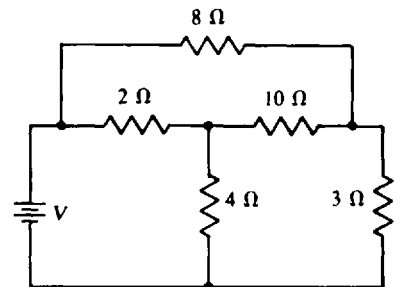

Fig. 5-59

5.69 In the lattice circuit shown in Fig. 5-57, what resistor substituted for the top 40-Ω resistor causes zero current flow in the 50-Ω resistor?

Ans. 90 Ω

5.70 If in the slide-wire bridge shown in Fig. 5-40, balance occurs with the slider at 67 cm from the top, what is the resistance R_x ?

Ans. 14.8 Ω

5.71 Use a Δ-Y transformation to find I in the circuit shown in Fig. 5-60. Remember that for a Δ-Y transformation, only the voltages and currents external to the Δ and Y do not change.

Ans. 0.334 A

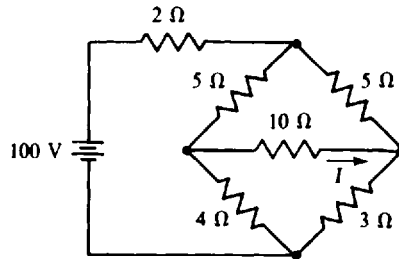

Fig. 5-60

5.72 In the circuit of Fig. 5-61, what resistor R_L will absorb maximum power, and what is this power?

Ans. 12 Ω, 192 W

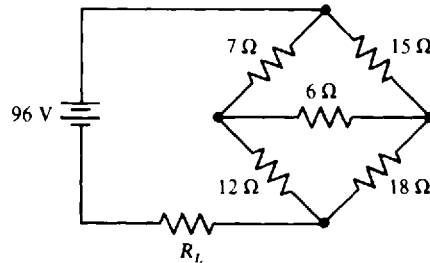

Fig. 5-61

5.73 In the circuit of Fig. 5-62, what resistor R_L will absorb maximum power, and what is this power?

Ans. 30 Ω, 1.48 W

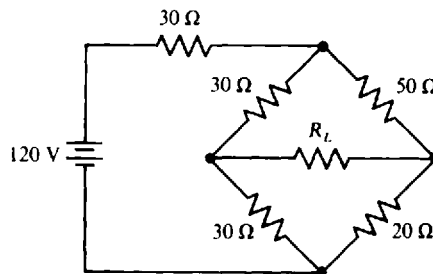

Fig. 5-62

Operational-Amplifier Circuits

INTRODUCTION

Operational amplifiers, usually called *op amps*, are important components of electronic circuits. Basically, an op amp is a very high-gain voltage amplifier, having a voltage gain of 100 000 or more. Although an op amp may consist of more than two dozen transistors, one dozen resistors, and perhaps one capacitor, it may be as small as an individual resistor. Because of its small size and relatively simple *external* operation, for purposes of an analysis or a design an op amp can often be considered as a single circuit element.

Figure 6-1a shows the circuit symbol for an op amp. The three terminals are an *inverting input terminal* a (marked $-$), a *noninverting input terminal* b (marked $+$), and an *output terminal* c . But a physical operational amplifier has more terminals. The extra two shown in Fig. 6-1b are for dc power supply inputs, which are often $+15\text{ V}$ and -15 V . Both positive and negative power supply voltages are required to enable the output voltage on terminal c to vary both positively and negatively with respect to ground.

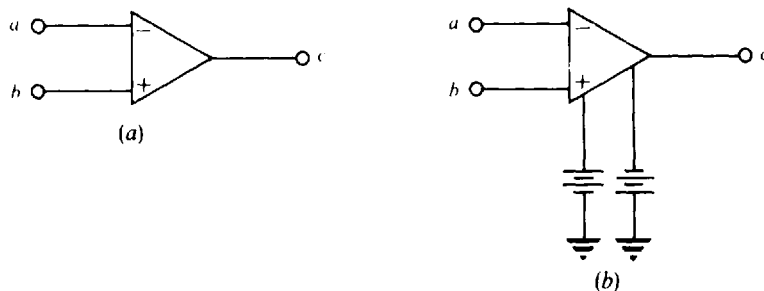

Fig. 6-1

OP-AMP OPERATION

The circuit of Fig. 6-2a, which is a model for an op amp, illustrates how an op amp operates as a voltage amplifier. As indicated by the dependent voltage source, for an open-circuit load the op amp provides an output voltage of $v_o = A(v_+ - v_-)$, which is A times the difference in input voltages. This A is often referred to as the *open-loop voltage gain*. From $A(v_+ - v_-)$, observe that a positive voltage v_+ applied to the noninverting input terminal b tends to make the output voltage positive, and a positive voltage v_- applied to the inverting input terminal a tends to make the output voltage negative.

The open-loop voltage gain A is typically so large (100 000 or more) that it can often be approximated by infinity (∞), as is shown in the simpler model of Fig. 6-2b. Note that Fig. 6-2b does not show the sources or circuits that provide the input voltage v_+ and v_- with respect to ground. Instead, just the voltages v_+ and v_- are shown. Doing this simplifies the circuit diagrams without any loss of information.

In Fig. 6-2a, the resistors shown at the input terminals have such large resistances (megohms) as compared to other resistances (usually kilohms) in a typical op-amp circuit, that they can be considered to be open circuits, as is shown in Fig. 6-2b. As a consequence, the input currents to an op amp are almost always negligibly small and assumed to be zero. This approximation is important to remember.

The output resistance R_o may be as large as $75\ \Omega$ or more, and so may not be negligibly small. When, however, an op amp is used with negative-feedback components (as will be explained), the effect of R_o is negligible, and so R_o can be replaced by a short circuit, as shown in Fig. 6-2b. Except for a few special op-amp circuits, negative feedback is always used.

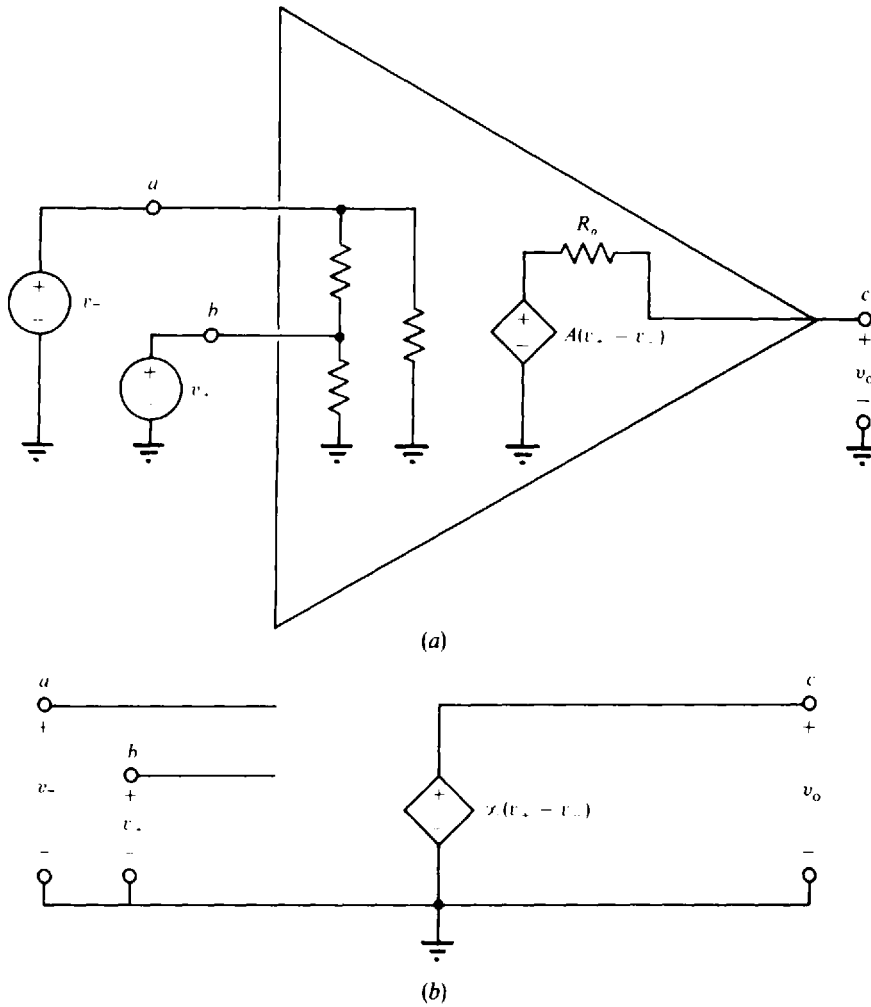

Fig. 6-2

The simple model of Fig. 6-2b is adequate for many practical applications. However, although not indicated, there is a limit to the output voltage: It cannot be greater than the positive supply voltage or less than the negative supply voltage. In fact, it may be several volts less in magnitude than the magnitude of the supply voltages, with the exact magnitude depending upon the current drawn from the output terminal. When the output voltage is at either extreme, the op amp is said to be *saturated* or to be *in saturation*. An op amp that is not saturated is said to be operating *linearly*.

Since the open-loop voltage gain A is so large and the output voltage is limited in magnitude, the voltage $v_+ - v_-$ across the input terminals has to be very small in magnitude for an op amp to operate linearly. Specifically, it must be less than $100 \mu\text{V}$ in a typical op-amp application. (This small voltage is obtained with *negative feedback*, as will be explained.) Because this voltage is negligible compared to the other voltages in a typical op-amp circuit, this voltage can be considered to be zero. This is a valid approximation for any op amp that is not saturated. But if an op amp is saturated, then the voltage difference $v_+ - v_-$ can be significantly large, and typically is.

Of less importance is the limit on the magnitude of the current that can be drawn from the op-amp output terminal. For one popular op amp this output current cannot exceed 40 mA.

The approximations of zero input current and zero voltage across the input terminals, as shown in Fig. 6-3, are the bases for the following analyses of popular op-amp circuits. In addition, nodal analysis will be used almost exclusively

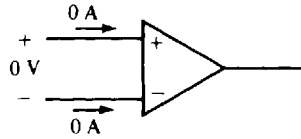

Fig. 6-3

POPULAR OP-AMP CIRCUITS

Figure 6-4 shows the *inverting amplifier*, or simply *inverter*. The input voltage is v_i and the output voltage is v_o . As will be shown, $v_o = Gv_i$ in which G is a *negative* constant. So, the output voltage v_o is similar to the input voltage v_i but is amplified and changed in sign (inverted).

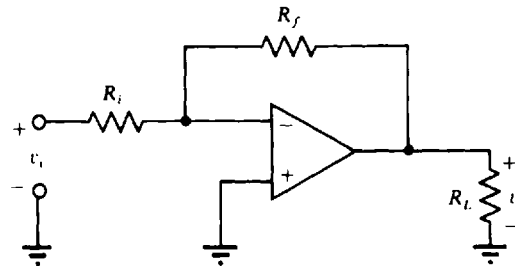

Fig. 6-4

As has been mentioned, it is *negative feedback* that provides the almost zero voltage across the input terminals of an op amp. To understand this, assume that in the circuit of Fig. 6-4 v_i is positive. Then a positive voltage appears at the inverting input because of the conduction path through resistor R_i . As a result, the output voltage v_o becomes negative. Because of the conduction path back through resistor R_f , this negative voltage also affects the voltage at the inverting input terminal and causes an almost complete cancellation of the positive voltage there. If the input voltage v_i had been negative instead then the voltage fed back would have been positive and again would have produced almost complete cancellation of the voltage across the op-amp input terminals.

This almost complete cancellation occurs only for a nonsaturated op amp. Once an op amp becomes saturated, however, the output voltage becomes constant and so the voltage fed back cannot increase in magnitude as the input voltage does.

In every op-amp circuit in this chapter, each op amp has a feedback resistor connected between the output terminal and the inverting input terminal. Consequently, in the *absence of saturation*, all the op amps in these circuits can be considered to have zero volts across the input terminals. They can also be considered to have zero currents into the input terminals because of the large input resistances.

The best way to obtain the voltage gain of the inverter of Fig. 6-4 is to apply KCL at the inverting input terminal. Before doing this, though, consider the following. Since the voltage across the op-amp input terminals is zero, and since the noninverting input terminal is grounded, it follows that the inverting input terminal is also effectively at ground. This means that all the input voltage v_i is across resistor R_i and that all the output voltage v_o is across resistor R_f . Consequently, the sum of the currents entering the inverting input terminal is

$$\frac{v_i}{R_i} + \frac{v_o}{R_f} = 0 \quad \text{and therefore} \quad v_o = -\frac{R_f}{R_i} v_i$$

So, the voltage gain is $G = -(R_f/R_i)$, which is the negative of the resistance of the feedback resistor divided by the resistance of the input resistor. This is an important formula to remember for

analyzing an op-amp inverter circuit or for designing one. (Do not confuse this gain G of the inverter circuit with the gain A of the op amp itself.)

It should be apparent that the input resistance is just R_i . Additionally, although the load resistor R_L affects the current that the op amp must provide, it has no effect on the voltage gain.

The *summing amplifier*, or *summer*, is shown in Fig. 6-5. Basically, a summer is an inverter circuit with more than one input. By convention, the sources for providing the input voltages v_a , v_b , and v_c are not shown. If this circuit is analyzed with the same approach used for the inverter, the result is

$$v_o = - \left(\frac{R_f}{R_a} v_a + \frac{R_f}{R_b} v_b + \frac{R_f}{R_c} v_c \right)$$

For the special case of all the resistances being the same, this formula simplifies to

$$v_o = -(v_a + v_b + v_c)$$

There is no special significance to the inputs being three in number. There can be two, four, or more inputs.

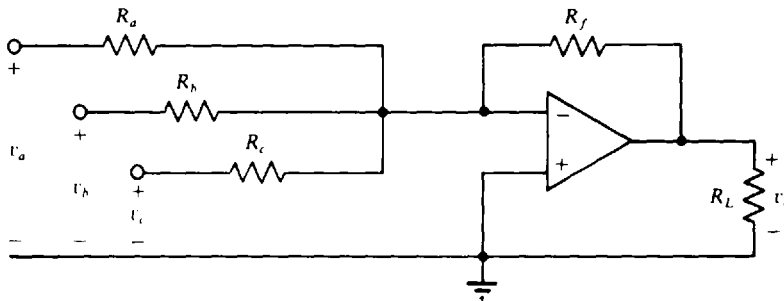

Fig. 6-5

Figure 6-6 shows the *noninverting voltage amplifier*. Observe that the input voltage v_i is applied at the noninverting input terminal. Because of the almost zero voltage across the input terminals, v_i is also effectively at the inverting input terminal. Consequently, the KCL equation at the inverting input terminal is

$$\frac{v_i}{R_a} + \frac{v_i - v_o}{R_f} = 0 \quad \text{which results in} \quad v_o = \left(1 + \frac{R_f}{R_a} \right) v_i$$

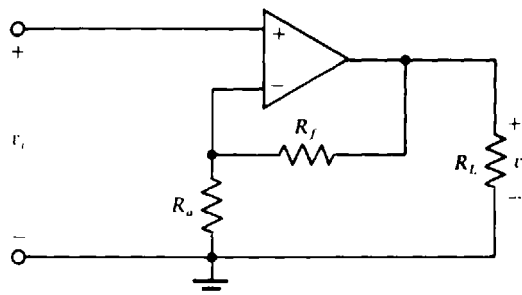

Fig. 6-6

Since the voltage gain of $1/(1 + R_f/R_a)$ does not have a negative sign, there is no inversion with this type of amplifier. Also, for the same resistances, the magnitude of the voltage gain is slightly greater than that of the inverter. But the big advantage that this circuit has over the inverter is a much greater input resistance. As a result, this amplifier will readily amplify the voltage from a source that has a large output resistance. In contrast, if an inverter is used, almost all the source voltage will be lost across the large output resistance of the source, as should be apparent from voltage division.

The *buffer amplifier*, also called the *voltage follower* or *unity-gain amplifier*, is shown in Fig. 6-7. It is basically a noninverting amplifier in which resistor R_a is replaced by an open circuit and resistor R_f by a short circuit. Because there is zero volts across the op-amp input terminals, the output voltage is equal to the input voltage: $v_o = v_i$. Therefore, the voltage gain is 1. This amplifier is used solely because of its large input resistance, in addition to the typical op-amp low output resistance.

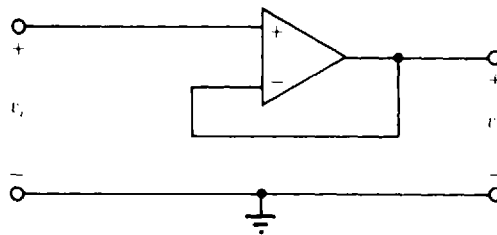

Fig. 6-7

There are applications, in which a voltage signal is to be converted to a proportional output current such as, for example, in driving a deflection coil in a television set. If the load is floating (neither end grounded), then the circuit of Fig. 6-8 can be used. This is sometimes called a *voltage-to-current converter*. Since there is zero volts across the op-amp input terminals, the current in resistor R_a is $i_L = v_i/R_a$, and this current also flows through the load resistor R_L . Clearly, the load current i_L is proportional to the signal voltage v_i .

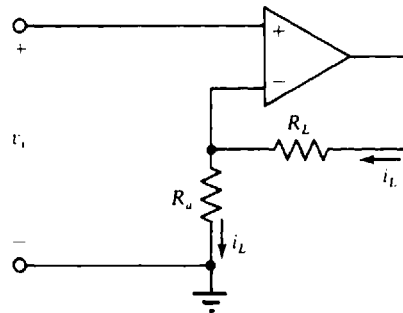

Fig. 6-8

The circuit of Fig. 6-8 can also be used for applications in which the load resistance R_L varies but the load current i_L must be constant. v_i is made a constant voltage and v_i and R_a are selected such that v_i/R_a is the desired current i_L . Consequently, when R_L varies, the load current i_L does not change. Of course, the load current cannot exceed the maximum allowable op-amp output current, and the load voltage plus the source voltage cannot exceed the maximum obtainable output voltage.

CIRCUITS WITH MULTIPLE OPERATIONAL AMPLIFIERS

Often, op-amp circuits are *cascaded*, as shown, for example, in the circuit of Fig. 6-9. In a cascade arrangement, the input to each op-amp stage is the output from a preceding op-amp stage, except, of

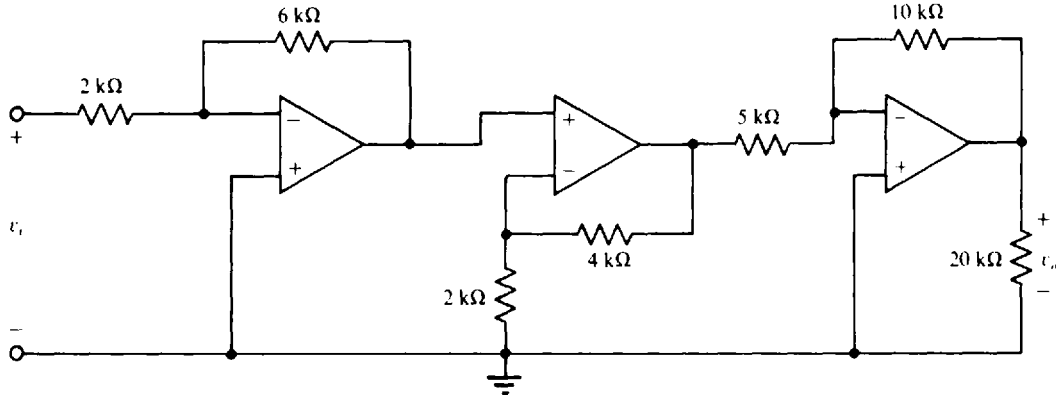

Fig. 6-9

course, for the first op-amp stage. Cascading is often used to improve the frequency response, which is a subject beyond the scope of the present discussion.

Because of the very low output resistance of an op-amp stage as compared to the input resistance of the following stage, there is no loading of the op-amp circuits. In other words, connecting the op-amp circuits together does not affect the operation of the individual op-amp circuits. This means that the overall voltage gain G_T is equal to the product of the individual voltage gains G_1, G_2, G_3, \dots ; that is, $G_T = G_1 \cdot G_2 \cdot G_3 \dots$.

To verify this formula, consider the circuit of Fig. 6-9. The first stage is an inverting amplifier, the second stage is a noninverting amplifier, and the last stage is another inverting amplifier. The output voltage of the first inverter is $-(6/2)v_i = -3v_i$, which is the input to the noninverting amplifier. The output voltage of this amplifier is $(1 + 4/2)(-3v_i) = -9v_i$. And this is the input to the inverter of the last stage. Finally, the output of this stage is $v_o = -9v_i(-10/5) = 18v_i$. So, the overall voltage gain is 18, which is equal to the product of the individual voltage gains: $G_T = (-3)(3)(-2) = 18$.

If a circuit contains multiple op-amp circuits that are not connected in a cascade arrangement, then another approach must be used. Nodal analysis is standard in such cases. Voltage variables are assigned to the op-amp output terminal nodes, as well as to other nongrounded nodes, in the usual manner. Then nodal equations are written at the nongrounded op-amp *input* terminals to take advantage of the known zero input currents. They are also written at the nodes at which the voltage variables are assigned, *except* for the nodes that are at the outputs of the op amps. The reason for this exception is that the op-amp output currents are unknown and if nodal equations are written at these nodes, additional current variables must be introduced, which increases the number of unknowns. Usually, this is undesirable. This standard analysis approach applies as well to a circuit that has just a single op amp.

Even if multiple op-amp circuits are not connected in cascade, they can sometimes be treated as if they were. This should be considered especially if the output voltage is fed back to op-amp inputs. Then the output voltage can often be viewed as another input and inserted into known voltage-gain formulas.

Solved Problems

- 6.1 Perform the following for the circuit of Fig. 6-10. Assume no saturation for parts (a) and (b). (a) Let $R_f = 12 \text{ k}\Omega$, $V_a = 2 \text{ V}$, and $V_b = 0 \text{ V}$. Determine V_o and I_o . (b) Repeat part (a) for $R_f = 9 \text{ k}\Omega$, $V_a = 4 \text{ V}$, and $V_b = 2 \text{ V}$. (c) Let $V_a = 5 \text{ V}$ and $V_b = 3 \text{ V}$ and determine the minimum value of R_f that will produce saturation if the saturation voltage levels are $V_o = \pm 14 \text{ V}$.

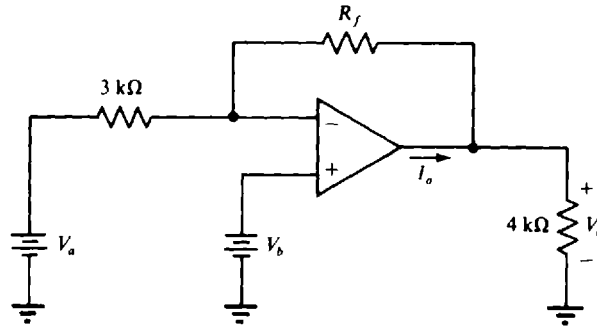

Fig. 6-10

- (a) Since for $V_b = 0$ V the circuit is an inverter, the inverter voltage-gain formula can be used to obtain V_o .

$$V_o = -\frac{12}{3}(2) = -8 \text{ V}$$

Then KCL applied at the output terminal gives

$$I_o = -\frac{8}{4} - \frac{8}{12} = -2.67 \text{ mA}$$

- (b) Because of the zero voltage across the op-amp input terminals, $V_- = V_b = 2$ V. Then, by KCL applied at the inverting op-amp input terminal,

$$\frac{4 - 2}{3} + \frac{V_o - 2}{9} = 0$$

The solution is $V_o = -4$ V. Another approach is to use superposition. Since the circuit is an inverter as regards V_a and is a noninverting amplifier as regards V_b , the output voltage is

$$V_o = -\frac{9}{3}(4) + \left(1 + \frac{9}{3}\right)(2) = -12 + 8 = -4 \text{ V}$$

With V_o known, KCL can be applied at the output terminal to obtain

$$I_o = -\frac{4}{4} + \frac{-4 - 2}{9} = -1.67 \text{ mA}$$

- (c) By superposition,

$$V_o = -\frac{R_f}{3}(5) + \left(1 + \frac{R_f}{3}\right)(3) = 3 - 0.667R_f$$

Since R_f must be positive, the op amp can saturate only at the specified -14 -V saturation voltage level. So,

$$-14 = 3 - 0.667R_f$$

the solution to which is $R_f = 25.5$ k Ω . This is the minimum value of R_f that will produce saturation. Actually the op amp will saturate for $R_f \geq 25.5$ k Ω .

- 6.2** Assume for the summer of Fig. 6-5 that $R_a = 4$ k Ω . Determine the values of R_b , R_c , and R_f that will provide an output voltage of $v_o = -(3v_a + 5v_b + 2v_c)$.

First, determine R_f . The contribution of v_a to v_o is $-(R_f/R_a)v_a$. Consequently, for a voltage gain of -3 and with $R_a = 4$ k Ω ,

$$-\frac{R_f}{4} = -3 \quad \text{and thus} \quad R_f = 12 \text{ k}\Omega$$

Next, determine R_b . The contribution of v_b to v_o is $-(R_f/R_b)v_b$. So, with $R_f = 12$ k Ω and for a voltage gain of -5 ,

$$-\frac{12}{R_b} = -5 \quad \text{and therefore} \quad R_b = \frac{12}{5} = 2.4 \text{ k}\Omega$$

Finally, the contribution of v_c to v_o is $-(R_f/R_c)v_c$. So, with $R_f = 12\text{ k}\Omega$ and for a voltage gain of -2 ,

$$-\frac{12}{R_c} = -2 \quad \text{which gives} \quad R_c = 6\text{ k}\Omega$$

- 6.3** In the circuit of Fig. 6-11, first find V_o and I_o for $V_a = 4\text{ V}$. Then assume op-amp voltage saturation levels of $V_o = \pm 12\text{ V}$ and determine the range of V_a for linear operation.

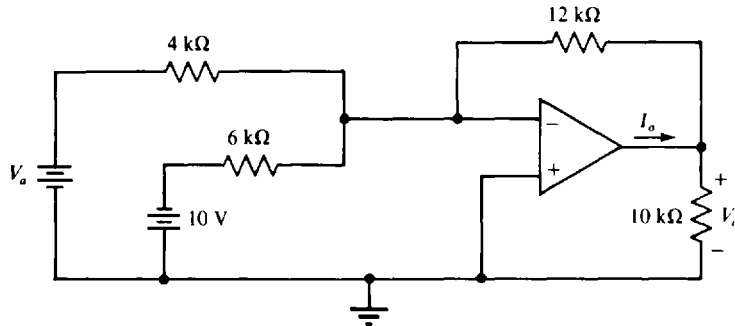

Fig. 6-11

Because this circuit is a summer,

$$V_o = -\left[\frac{12}{4}(4) + \frac{12}{6}(-10)\right] = 8\text{ V} \quad \text{and} \quad I_o = \frac{8}{10} + \frac{8}{12} = 1.47\text{ mA}$$

Now, finding the range of V_a for linear operation,

$$\pm 12 = -\left[\frac{12}{4}(V_a) + \frac{12}{6}(-10)\right] = -3V_a + 20$$

Therefore, $V_a = (20 \pm 12)/3$. So, for linear operation, V_a must be less than $(20 + 12)/3 = 10.7\text{ V}$ and greater than $(20 - 12)/3 = 2.67\text{ V}$: $2.67\text{ V} < V_a < 10.7\text{ V}$.

- 6.4** Calculate V_o and I_o in the circuit of Fig. 6-12.

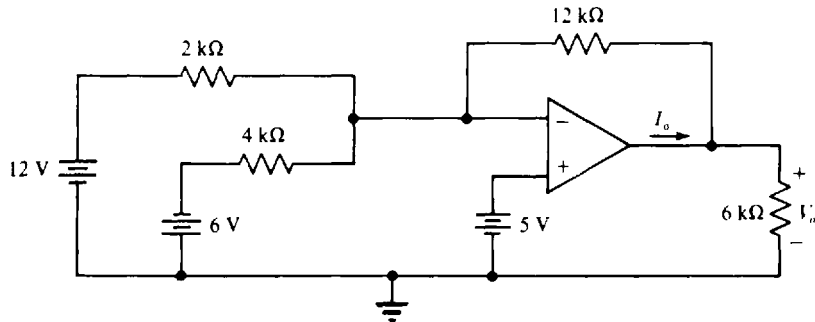

Fig. 6-12

Because of the zero voltage drop across the op-amp input terminals, the voltage with respect to ground at the inverting input terminal is the same 5 V that is at the noninverting input terminal. With this voltage known, the voltage V_o can be determined from summing the currents flowing into the inverting input terminal:

$$\frac{12 - 5}{2} + \frac{-6 - 5}{4} + \frac{V_o - 5}{12} = 0$$

Thus, $V_o = -4\text{ V}$. Finally, applying KCL at the output terminal gives

$$I_o = \frac{-4}{6} + \frac{-4 - 5}{12} = -1.42\text{ mA}$$

- 6.5 In the circuit of Fig. 6-13a, a 10-kΩ load resistor is energized by a source of voltage v_s that has an internal resistance of 90 kΩ. Determine v_L , and then repeat this for the circuit of Fig. 6-13b.

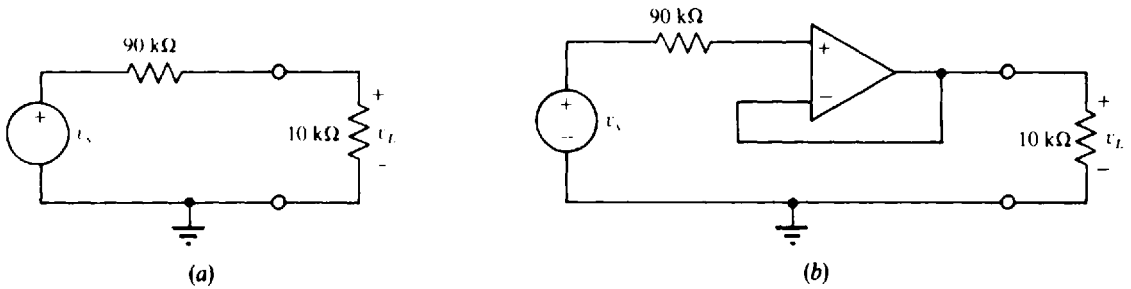

Fig. 6-13

Voltage division applied to the circuit of Fig. 6-13a gives

$$v_L = \frac{10}{10 + 90} v_s = 0.1v_s$$

So, only 10 percent of the source voltage reaches the load. The other 90 percent is lost across the internal resistance of the source.

For the circuit of Fig. 6-13b, no current flows in the signal source because of the large op-amp input resistance. Consequently, there is a zero voltage drop across the source internal resistance, and the entire source voltage appears at the noninverting input terminal. Finally, since there is zero volts across the op-amp input terminals, $v_L = v_s$. So, the insertion of the voltage follower results in an increase in the load voltage from $0.1v_s$ to v_s .

Note that although no current flows in the 90-kΩ resistor in the circuit of Fig. 6-13b, there is current flow in the 10-kΩ resistor, the path for which is not evident from the circuit diagram. For a positive v_L , this current flows down through the 10-kΩ resistor to ground, then through the op-amp power supplies (not shown), and finally through the op-amp internal circuitry to the op-amp output terminal.

- 6.6 Obtain the input resistance R_{in} of the circuit of Fig. 6-14a.

The input resistance R_{in} can be determined in the usual way, by applying a source and obtaining the ratio of the source voltage to the source current that flows out of the positive terminal of the source. Figure 6-14b shows a source of voltage V_s applied. Because of the zero current flow into the op-amp noninverting input terminal, all the source current I_s flows through R_f , thereby producing a voltage of $I_s R_f$ across it, as shown. Since the voltage across the op-amp input terminals is zero, this voltage is also across R_a and results in a current flow to the right of $I_s R_f / R_a$. Because of the zero current flow

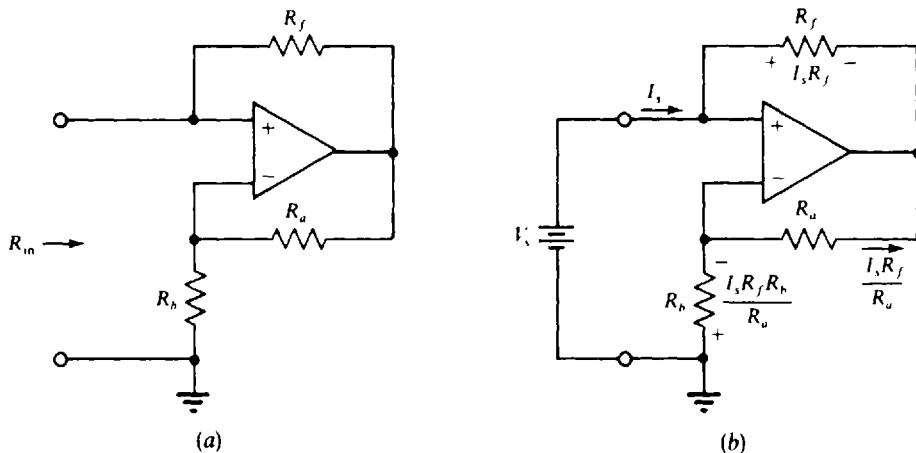

Fig. 6-14

into the op-amp inverting input terminal, this current also flows *up* through R_b , resulting in a voltage across it of $I_s R_f R_b / R_a$, positive at the bottom. Then, KVL applied to the left-hand mesh gives

$$V_s + 0 + \frac{I_s R_f R_b}{R_a} = 0 \quad \text{and so} \quad R_{in} = \frac{V_s}{I_s} = -\frac{R_f R_b}{R_a}$$

The input resistance being negative means that this op-amp circuit will cause current to flow *into* the positive terminal of any voltage source that is connected across the input terminals, provided that the op amp is not saturated. Consequently, the op-amp circuit supplies power to this voltage source. But, of course, this power is really supplied by the dc voltage sources that energize the op amp.

6.7 For the circuit of Fig. 6-14a, let $R_f = 6 \text{ k}\Omega$, $R_b = 4 \text{ k}\Omega$, and $R_a = 8 \text{ k}\Omega$, and determine the power that will be supplied to a 4.5-V source that is connected across the input terminals.

From the solution to Prob. 6.6,

$$R_{in} = -\frac{R_f R_b}{R_a} = -\frac{6(4)}{8} = -3 \text{ k}\Omega$$

Therefore, the current that flows *into* the positive terminal of the source is $4.5/3 = 1.5 \text{ mA}$. Consequently, the power supplied to the source is $4.5(1.5) = 6.75 \text{ mW}$.

6.8 Obtain an expression for the voltage v_o in the circuit of Fig. 6-15.

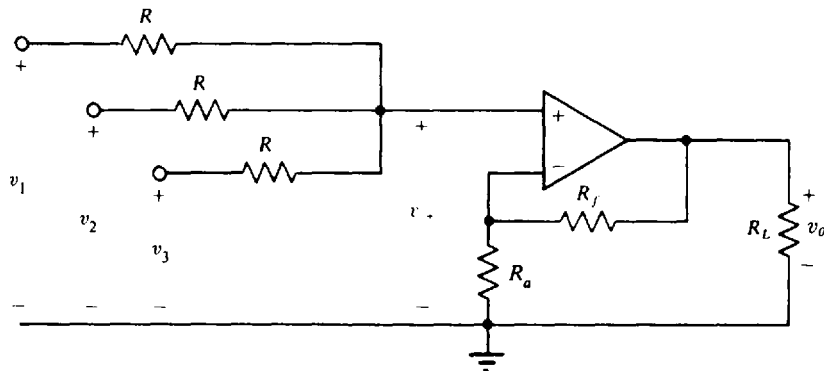

Fig. 6-15

Clearly, in terms of v_+ , this circuit is a noninverting amplifier. So,

$$v_o = \left(1 + \frac{R_f}{R_a}\right)v_+$$

The voltage v_+ can be found by applying nodal analysis at the noninverting input terminal.

$$\frac{v_1 - v_+}{R} + \frac{v_2 - v_+}{R} + \frac{v_3 - v_+}{R} = 0 \quad \text{from which} \quad v_+ = \frac{1}{3}(v_1 + v_2 + v_3)$$

Finally, substituting for v_+ yields

$$v_o = \frac{1}{3} \left(1 + \frac{R_f}{R_a}\right)(v_1 + v_2 + v_3)$$

From this result it is evident that the circuit of Fig. 6-15 is a *noninverting summer*. The number of inputs is not limited to three. In general,

$$v_o = \frac{1}{n} \left(1 + \frac{R_f}{R_a}\right)(v_1 + v_2 + \dots + v_n)$$

in which n is the number of inputs.

- 6.9** In the circuit of Fig. 6-15, assume that $R_f = 6 \text{ k}\Omega$ and then determine the values of the other resistors required to obtain $v_o = 2(v_1 + v_2 + v_3)$.

From the solution to Prob. 6.8, the multiplier of the voltage sum is

$$\frac{1}{3} \left(1 + \frac{6}{R_a} \right) = 2 \quad \text{the solution to which is} \quad R_a = 1.2 \text{ k}\Omega$$

As long as the value of R is reasonable, say in the kilohm range, it does not matter much what the specific value is. Similarly, the specific value of R_L does not affect v_o provided R_L is in the kilohm range or greater.

- 6.10** Obtain an expression for the voltage gain of the op-amp circuit of Fig. 6.16.

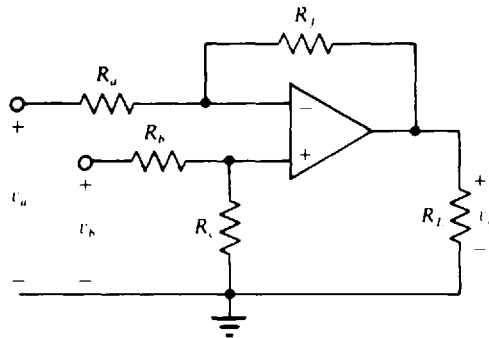

Fig. 6-16

Superposition is a good approach to use here. If $v_b = 0 \text{ V}$, then the voltage at the noninverting input terminal is zero, and so the amplifier becomes an inverting amplifier. Consequently, the contribution of v_a to the output voltage v_o is $-(R_f/R_a)v_a$. On the other hand, if $v_a = 0 \text{ V}$, the circuit becomes a noninverting amplifier that amplifies the voltage at the noninverting input terminal. By voltage division, this voltage is $R_c v_b / (R_b + R_c)$. Therefore, the contribution of v_b to the output voltage v_o is

$$-\frac{R_c}{R_b + R_c} \left(1 + \frac{R_f}{R_a} \right) v_b = \frac{R_c(R_a + R_f)}{R_a(R_b + R_c)} v_b$$

Finally, by superposition the output voltage is

$$v_o = \frac{R_c(R_a + R_f)}{R_a(R_b + R_c)} v_b - \frac{R_f}{R_a} v_a$$

This voltage-gain formula can be simplified by the selection of resistances such that $R_a/R_f = R_b/R_c$. The result is

$$v_o = \frac{R_f}{R_a} (v_b - v_a)$$

in which case the output voltage v_o is a constant times the difference $v_b - v_a$ of the two input voltages. This constant can, of course, be made 1 by the selection of $R_f = R_a$. For obvious reasons the circuit of Fig. 6-16 is called a *difference amplifier*.

- 6.11** For the difference amplifier of Fig. 6-16, let $R_f = 8 \text{ k}\Omega$ and then determine values of R_a , R_b , and R_c to obtain $v_o = 4(v_b - v_a)$.

From the solution to Prob. 6.10, the contribution of $-4v_a$ to v_o requires that $R_f/R_a = 8/R_a = 4$, and so $R_a = 2 \text{ k}\Omega$. For this value of R_a and for $R_f = 8 \text{ k}\Omega$, the multiplier of v_b becomes

$$\frac{R_c}{R_b + R_c} \left(1 + \frac{8}{2} \right) = 4 \quad \text{or} \quad \frac{R_c}{R_b + R_c} = \frac{4}{5}$$

Inverting results in

$$\frac{R_b}{R_c} + 1 = \frac{5}{4} \quad \text{or} \quad \frac{R_b}{R_c} = \frac{1}{4}$$

Therefore, $R_c = 4R_b$ gives the desired response, and obviously there is no unique solution, as is typical of the design process. So, if R_b is selected as 1 kΩ, then $R_c = 4$ kΩ. And for $R_b = 2$ kΩ, $R_c = 8$ kΩ, and so on.

6.12 Find V_o in the circuit of Fig. 6-17.

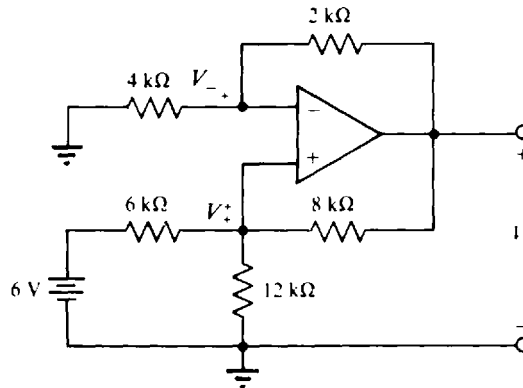

Fig. 6-17

By nodal analysis at the noninverting input terminal,

$$\frac{V_+}{12} + \frac{V_+ - V_o}{8} + \frac{V_+ - 6}{6} = 0$$

which simplifies to $V_o = 3V_+ - 8$. But by voltage division,

$$V_- = V_+ = \frac{4}{4 + 2} V_o = \frac{2}{3} V_o$$

And so,

$$V_o = 3\left(\frac{2}{3} V_o\right) - 8 \quad \text{from which} \quad V_o = 8 \text{ V}$$

6.13 For the op-amp circuit of Fig. 6-18, calculate V_o . Then assume op-amp saturation voltages of ± 14 V, and find the resistance of the feedback resistor R_f that will result in saturation of the op amp.

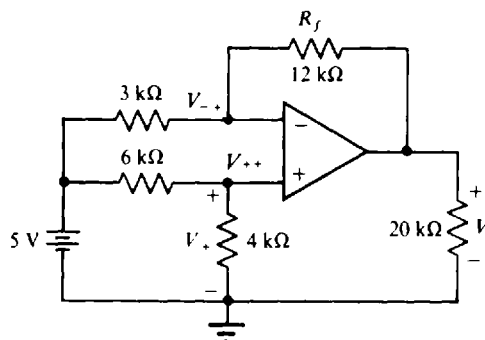

Fig. 6-18

By voltage division,

$$V_+ = \frac{4}{4+6} \times 5 = 2 \text{ V}$$

Then since $V_- = V_+ = 2 \text{ V}$, the node-voltage equation at the inverting input terminal is

$$\frac{5-2}{3} + \frac{V_o-2}{12} = 0 \quad \text{which results in} \quad V_o = -10 \text{ V}$$

Now, R_f is to be changed to obtain saturation at one of the two voltage saturation levels. From KCL applied at the inverting input terminal,

$$\frac{5-2}{3} + \frac{V_o-2}{R_f} = 0 \quad \text{or} \quad R_f + V_o - 2 = 0$$

So, $R_f = 2 - V_o$. Clearly, for a positive resistance value of R_f , the saturation must be at the negative voltage level of -14 V . Consequently, $R_f = 2 - (-14) = 16 \text{ k}\Omega$. Actually, this is the minimum value of R_f that gives saturation. There is saturation for $R_f \geq 16 \text{ k}\Omega$.

6.14 For the circuit of Fig. 6-19, calculate the voltage V_o and the current I_o .

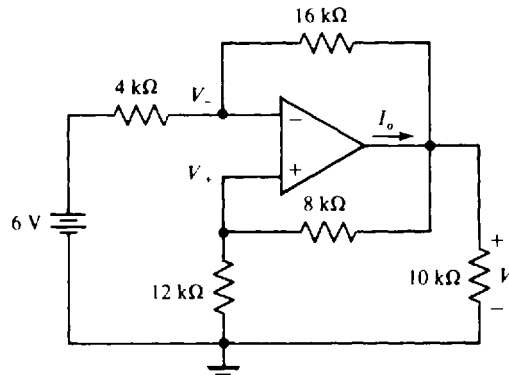

Fig. 6-19

In Fig. 6-19, observe the lack of polarity references for V_- and V_+ . Polarity references are not essential because these voltages are always referenced positive with respect to ground. Likewise the polarity reference for V_o could have been omitted.

By voltage division,

$$V_+ = V_- = \frac{12}{12+8} V_o = 0.6V_o$$

With $V_- = 0.6V_o$, the node-voltage equation at the inverting input terminal is

$$\frac{6-0.6V_o}{4} + \frac{V_o-0.6V_o}{16} = 0 \quad \text{which simplifies to} \quad V_o = 12 \text{ V}$$

The current I_o can be obtained from applying KCL at the op-amp output terminal:

$$I_o = \frac{12}{10} + \frac{12}{8+12} + \frac{12-0.6(12)}{16} = 2.1 \text{ mA}$$

6.15 Determine V_o and I_o in the circuit of Fig. 6-20.

The voltage V_o can be found by writing nodal equations at the inverting input terminal and at the V_1 node and using the fact that the inverting input terminal is effectively at ground. From summing currents

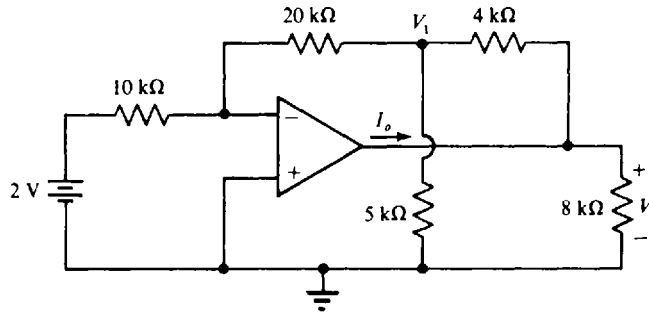

Fig. 6-20

into the inverting input terminal and away from the V_1 node, these equations are

$$\frac{2}{10} + \frac{V_1}{20} = 0 \quad \text{and} \quad \frac{V_1}{20} + \frac{V_1}{5} + \frac{V_1 - V_o}{4} = 0$$

which simplify to

$$V_1 = -4 \text{ V} \quad \text{and} \quad 10V_1 - 5V_o = 0$$

Consequently,

$$V_o = 2V_1 = 2(-4) = -8 \text{ V}$$

Finally, I_o is equal to the sum of the currents flowing away from the op-amp output terminal through the 8-k Ω and 4-k Ω resistors:

$$I_o = \frac{-8}{8} + \frac{-8 - (-4)}{4} = -2 \text{ mA}$$

6.16 Find V_o in the circuit of Fig. 6-21.

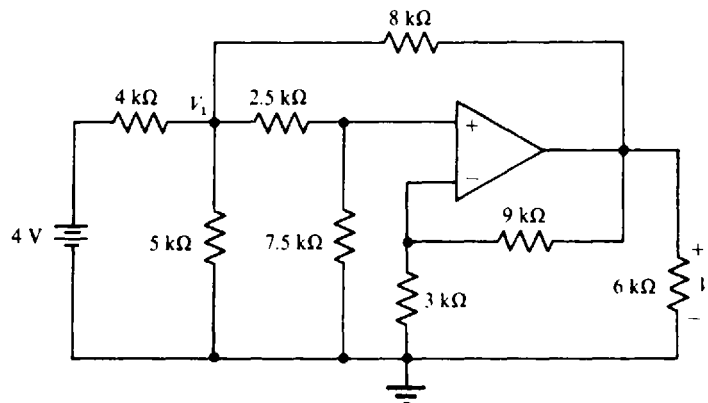

Fig. 6-21

The node-voltage equation at the V_1 node is

$$\left(\frac{1}{5} + \frac{1}{4} + \frac{1}{2.5 + 7.5} + \frac{1}{8}\right)V_1 - \frac{1}{8}V_o = \frac{4}{4}$$

which upon multiplication by 40 becomes $27V_1 - 5V_o = 40$. Also, by voltage division,

$$V_+ = \frac{7.5}{7.5 + 2.5} V_1 = 0.75V_1$$

Further, since the op amp and the 9-k Ω and 3-k Ω resistors form a noninverting amplifier,

$$V_o = (1 + \frac{9}{3})(0.75V_1) = 3V_1 \quad \text{or} \quad V_1 = \frac{1}{3}V_o$$

Finally, substitution for V_1 in the node-voltage equation yields

$$27\left(\frac{V_o}{3}\right) - 5V_o = 40 \quad \text{and so} \quad V_o = 10 \text{ V}$$

6.17 Determine V_o in the circuit of Fig. 6-22.

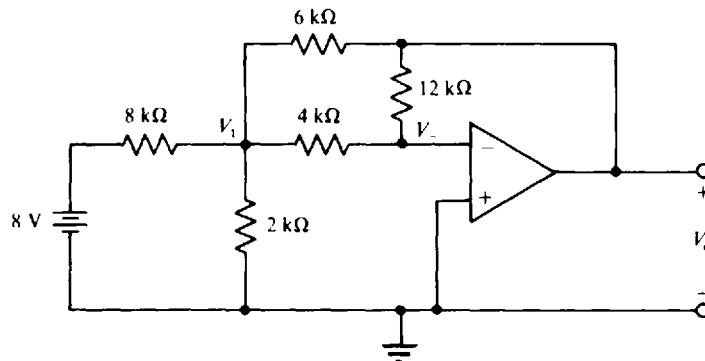

Fig. 6-22

Since $V_- = 0 \text{ V}$, the node-voltage equations at the V_1 and inverting-input terminal nodes are

$$\frac{V_1}{2} + \frac{V_1}{4} + \frac{V_1 - 8}{8} + \frac{V_1 - V_o}{6} = 0 \quad \text{and} \quad \frac{V_1}{4} + \frac{V_o}{12} = 0$$

Multiplying the first equation by 24 and the second equation by 12 gives

$$25V_1 - 4V_o = 24 \quad \text{and} \quad 3V_1 + V_o = 0$$

from which V_o can be readily obtained: $V_o = -1.95 \text{ V}$.

6.18 Assume for the op amp in the circuit of Fig. 6-23 that the saturation voltages are $V_o = \pm 14 \text{ V}$ and that $R_f = 6 \text{ k}\Omega$. Then determine the maximum resistance of R_a that results in the saturation of the op amp.

The circuit of Fig. 6-23 is a noninverting amplifier, the voltage gain of which is $G = 1 + 6/2 = 4$. Consequently, $V_o = 4V_+$, and for saturation at the positive level (the only saturation possible), $V_+ = 14/4 = 3.5 \text{ V}$. The resistance of R_a that will result in this voltage can be obtained by using voltage division:

$$V_+ = \frac{10}{10 + R_a} \times 4.9 = 3.5 \quad \text{or} \quad 49 = 35 + 3.5R_a$$

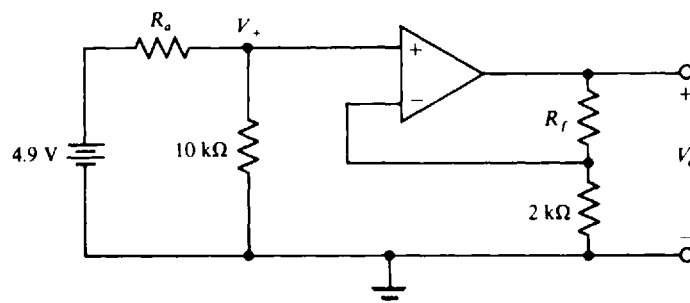

Fig. 6-23

and thus

$$R_a = \frac{14}{3.5} = 4 \text{ k}\Omega$$

This is the maximum value of resistance for R_a for which there is saturation. Actually, saturation occurs for $R_a \leq 4 \text{ k}\Omega$.

- 6.19** In the circuit of Fig. 6-23, assume that $R_a = 2 \text{ k}\Omega$, and then find what the resistance of R_f must be for the op amp to operate in the linear mode. Assume saturation voltages of $V_o = \pm 14 \text{ V}$.

With $R_a = 2 \text{ k}\Omega$, the voltage V_+ is, by voltage division,

$$V_+ = \frac{10}{10 + 2} \times 4.9 = 4.08 \text{ V}$$

Then for $V_o = 14 \text{ V}$, the output voltage equation is

$$14 = 4.08 \left(1 + \frac{R_f}{2} \right) = 4.08 + 2.04R_f$$

Therefore,

$$R_f = \frac{14 - 4.08}{2.04} = 4.86 \text{ k}\Omega$$

Clearly, then, for V_o to be less than the saturation voltage of 14 V , the resistance of the feedback resistor R_f must be less than $4.86 \text{ k}\Omega$.

- 6.20** Obtain the Thévenin equivalent of the circuit of Fig. 6-24 with V_{Th} referenced positive at terminal a .

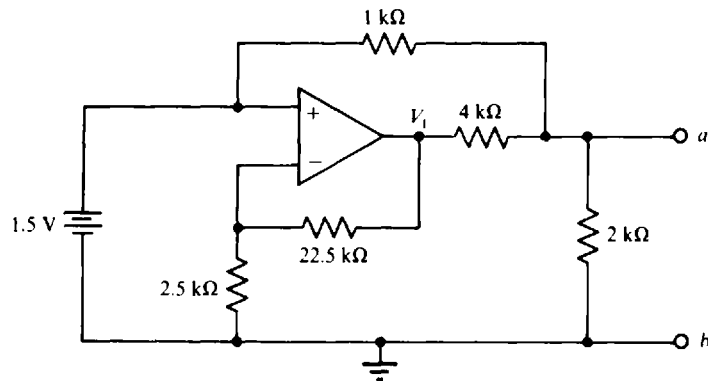

Fig. 6-24

By inspection, the part of the circuit comprising the op amp and the $2.5\text{-k}\Omega$ and $22.5\text{-k}\Omega$ resistors is a noninverting amplifier. Consequently,

$$V_1 = \left(1 + \frac{22.5}{2.5} \right) \times 1.5 = 15 \text{ V}$$

Since $V_{Th} = V_{ab}$, the node voltage equation at terminal a is

$$\frac{V_{Th}}{2} + \frac{V_{Th} - 1.5}{1} + \frac{V_{Th} - 15}{4} = 0 \quad \text{and so} \quad V_{Th} = 3 \text{ V}$$

If a short circuit is placed across terminals a and b , then

$$I_{sc} = I_{ab} = \frac{1.5}{1} + \frac{15}{4} = 5.25 \text{ mA}$$

Consequently,

$$R_{Th} = \frac{V_{Th}}{I_{sc}} = \frac{3}{5.25} = 0.571 \text{ k}\Omega$$

6.21 Calculate V_o in the circuit of Fig. 6-25.

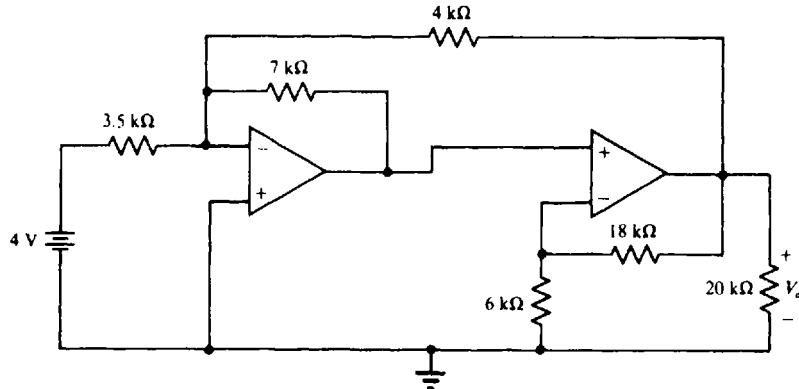

Fig. 6-25

Although nodal analysis can be applied, it is simpler to view this circuit as a summer cascaded with a noninverting amplifier. The summer has two inputs, V_o and 4 V. Consequently, through use of the summer and noninverting voltage formulas,

$$V_o = -\left(\frac{7}{3.5} \times 4 + \frac{7}{4} V_o\right) \left(1 + \frac{18}{6}\right) = -32 - 7V_o$$

So,

$$8V_o = -32 \quad \text{and} \quad V_o = -4 \text{ V}$$

6.22 Find V_o in the circuit of Fig. 6-26.

The circuit of Fig. 6-26 can be viewed as two cascaded summers, with V_o being one of the two inputs to the first summer. The other input is 3 V. Then, the output V_1 of the first summer is

$$V_1 = -\left[\frac{12}{2}(3) + \frac{12}{6} V_o\right] = -18 - 2V_o$$

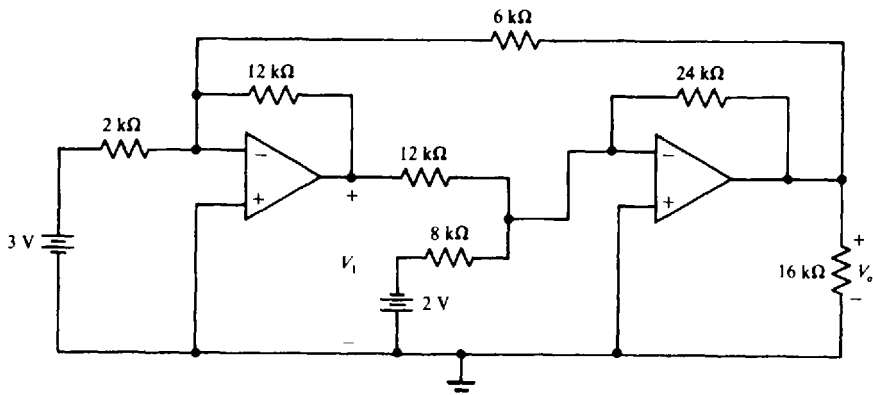

Fig. 6-26

The output V_o of the second summer is

$$V_o = -\left[\frac{2^4}{8}(-2) + \frac{2^4}{12}V_1\right] = 6 - 2V_1$$

Substituting for V_1 gives

$$V_o = 6 - 2(-18 - 2V_o) = 6 + 36 + 4V_o$$

Finally, $V_o = -\frac{42}{3} = -14$ V.

6.23 Determine V_o in the circuit of Fig. 6-27.

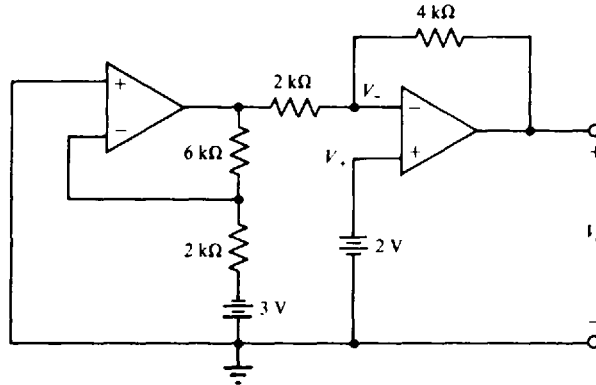

Fig. 6-27

In this cascaded arrangement, the first op-amp circuit is an inverting amplifier. Consequently, the op-amp output voltage is $-(6/2)(-3) = 9$ V. For the second op amp, observe that $V_- = V_+ = 2$ V. Thus, the nodal equation at the inverting input terminal is

$$\frac{9 - 2}{2} + \frac{V_o - 2}{4} = 0 \quad \text{and so} \quad V_o = -12 \text{ V}$$

Perhaps a better approach for the second op-amp circuit is to apply superposition, as follows:

$$V_o = -\frac{4}{2}(9) + \left(1 + \frac{4}{2}\right)(2) = -18 + 6 = -12 \text{ V}$$

6.24 Find V_{1o} and V_{2o} in the circuit of Fig. 6-28.

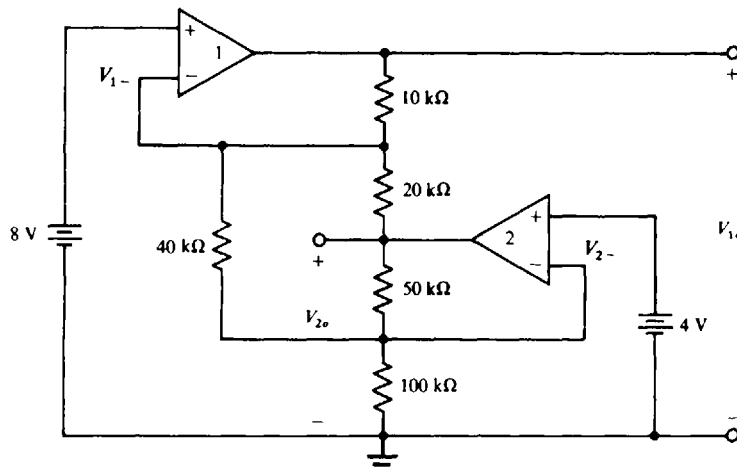

Fig. 6-28

Before starting the analysis, observe that because of the zero voltages across the op-amp input terminals, the inverting input voltages are $V_{1-} = 8 \text{ V}$ and $V_{2-} = 4 \text{ V}$. The two equations needed to relate the output voltages can be obtained by applying KCL at the two inverting input terminals. These equations are

$$\frac{8 - V_{1o}}{10} + \frac{8 - V_{2o}}{20} + \frac{8 - 4}{40} = 0 \quad \text{and} \quad \frac{4 - V_{2o}}{50} + \frac{4}{100} + \frac{4 - 8}{40} = 0$$

These equations simplify to

$$4V_{1o} + 2V_{2o} = 52 \quad \text{and} \quad 2V_{2o} = 2$$

The solutions to these equations are $V_{1o} = 12.5 \text{ V}$ and $V_{2o} = 1 \text{ V}$.

- 6.25** For the circuit of Fig. 6-29, calculate V_{1o} , V_{2o} , I_1 , and I_2 . Assume that the op-amp saturation voltages are $\pm 14 \text{ V}$.

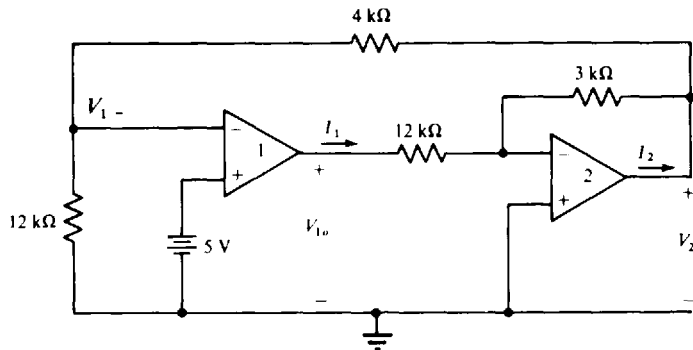

Fig. 6-29

Observe that op amp 1 has no negative feedback and so is probably in saturation, and it is saturated at 14 V because of the 5 V applied to the *noninverting* input terminal. Assume this is so. Then this 14 V is an input to the circuit portion containing op amp 2, which is an inverter. Consequently, $V_{2o} = -(3/12)(14) = -3.5 \text{ V}$. And, by voltage division,

$$V_{1-} = \frac{12}{12 + 4} (-3.5) = -2.625 \text{ V}$$

Since this negative voltage is applied to the *inverting* input of op amp 1, both inputs to this op amp tend to make the op-amp output positive. Also, the voltage across the op-amp input terminals is not approximately zero. For both of these reasons, the assumption is confirmed that op amp 1 is saturated at the positive saturation level. Therefore, $V_{1o} = 14 \text{ V}$ and $V_{2o} = -3.5 \text{ V}$. Finally, by KCL,

$$I_1 = \frac{14}{12} = 1.17 \text{ mA} \quad \text{and} \quad I_2 = \frac{-3.5}{3} + \frac{-3.5}{4 + 12} = -1.39 \text{ mA}$$

Supplementary Problems

- 6.26** Obtain an expression for the load current i_L in the circuit of Fig. 6-30 and show that this circuit is a voltage-to-current converter, or a constant current source, suitable for a grounded-load resistor.

Ans. $i_L = -v_i/R$; i_L is proportional to v_i and is independent of R_L

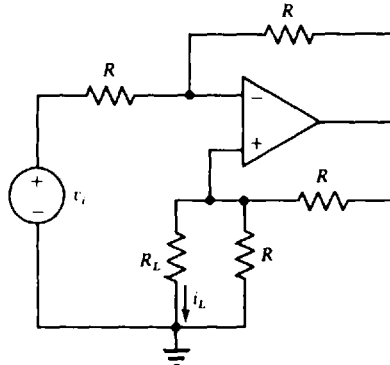

Fig. 6-30

6.27 Find V_o in the circuit of Fig. 6-31.

Ans. -4 V

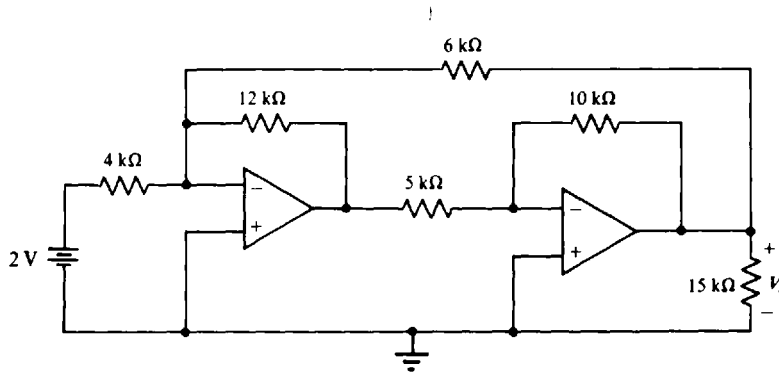

Fig. 6-31

6.28 Assume for the summer of Fig. 6-5 that $R_b = 12\text{ k}\Omega$, and obtain the values of R_a , R_c , and R_f that will result in an output voltage of $v_o = -(8v_a + 4v_b + 6v_c)$.

Ans. $R_a = 6\text{ k}\Omega$, $R_c = 8\text{ k}\Omega$, $R_f = 48\text{ k}\Omega$

6.29 In the circuit of Fig. 6-32, determine V_o and I_o for $V_a = 6\text{ V}$ and $V_b = 0\text{ V}$.

Ans. -5 V , -0.625 mA

6.30 Repeat Prob. 6.29 for $V_a = 16\text{ V}$ and $V_b = 4\text{ V}$.

Ans. 10 V , 1.08 mA

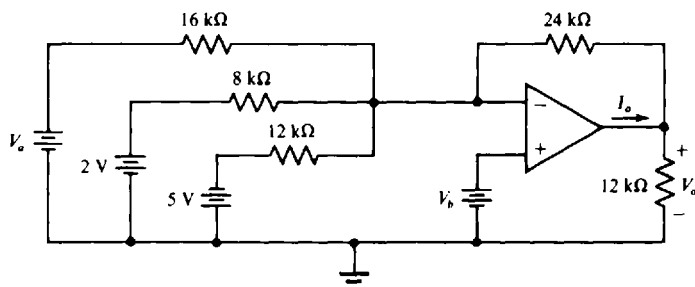

Fig. 6-32

6.31 For the circuit of Fig. 6-32, assume that the op-amp saturation voltages are ± 14 V and that $V_b = 0$ V. Determine the range of V_a for linear operation.

Ans. -6.67 V $< V_a < 12$ V

6.32 For the difference amplifier of Fig. 6-16, let $R_f = 12$ k Ω , and determine the values of R_a , R_b , and R_c to obtain $v_o = v_b - 2v_a$.

Ans. $R_a = 6$ k Ω ; R_b and R_c have resistances such that $R_b = 2R_c$

6.33 In the circuit of Fig. 6-33, let $V_s = 4$ V and calculate V_o and I_o .

Ans. 7.2 V, 1.8 mA

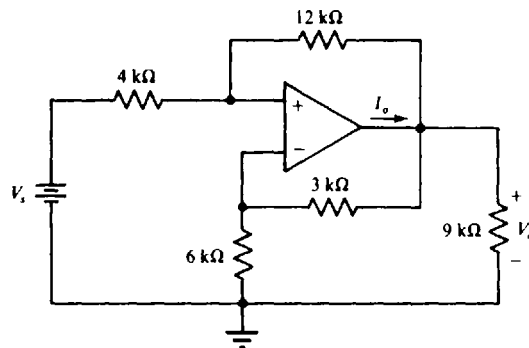

Fig. 6-33

6.34 For the op-amp circuit of Fig. 6-33, find the range of V_s for linear operation if the op-amp saturation voltages are $V_o = \pm 14$ V.

Ans. -7.78 V $< V_s < 7.78$ V

6.35 For the circuit of Fig. 6-34, calculate V_o and I_o for $V_a = 0$ V and $V_b = 12$ V.

Ans. -12 V, -7.4 mA

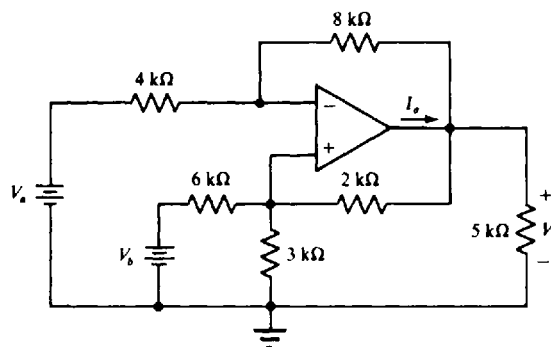

Fig. 6-34

6.36 Repeat Prob. 6.35 for $V_a = 4$ V and $V_b = 8$ V.

Ans. 8 V, 3.27 mA

6.37 Determine V_o and I_o in the circuit of Fig. 6-35 for $V_a = 1.5$ V and $V_b = 0$ V.

Ans. -11 V, -6.5 mA

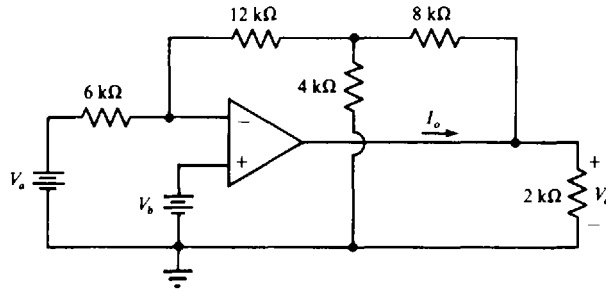

Fig. 6-35

6.38 Repeat Prob. 6.37 for $V_a = 5\text{ V}$ and $V_b = 3\text{ V}$.

Ans. -5.67 V , -3.42 mA

6.39 Obtain V_o and I_o in the circuit of Fig. 6-36 for $V_a = 12\text{ V}$ and $V_b = 0\text{ V}$.

Ans. 10.8 V , 4.05 mA

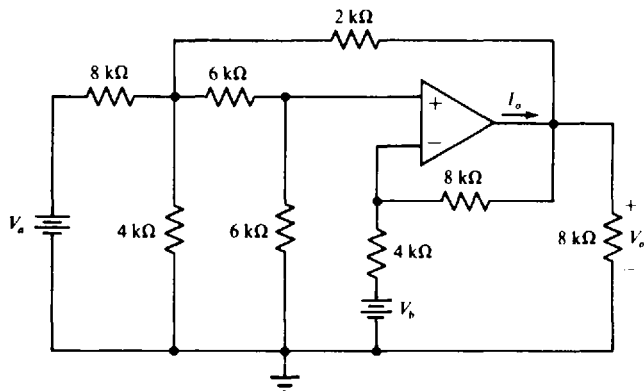

Fig. 6-36

6.40 Repeat Prob. 6.39 for $V_a = 4\text{ V}$ and $V_b = 2\text{ V}$.

Ans. -14.8 V , -7.05 mA

6.41 In the circuit of Fig. 6-37, calculate V_o if $V_s = 4\text{ V}$.

Ans. -3.10 V

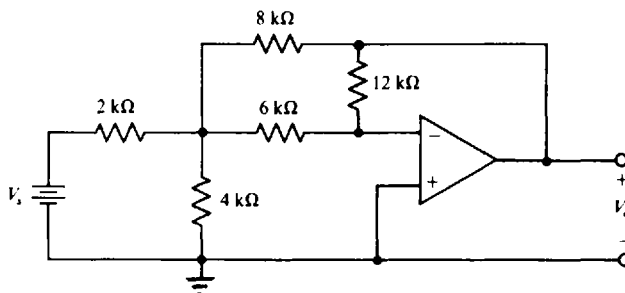

Fig. 6-37

- 6.42** Assume for the circuit of Fig. 6-37 that the op-amp saturation voltages are $V_o = \pm 14$ V. Determine the minimum positive value of V_s that will produce saturation.

Ans. 18.1 V

- 6.43** Assume for the op-amp in the circuit of Fig. 6-38 that the saturation voltages are $V_o = \pm 14$ V and that $R_f = 12$ k Ω . Calculate the range of values of R_a that will result in saturation of the op amp.

Ans. $R_a \geq 7$ k Ω

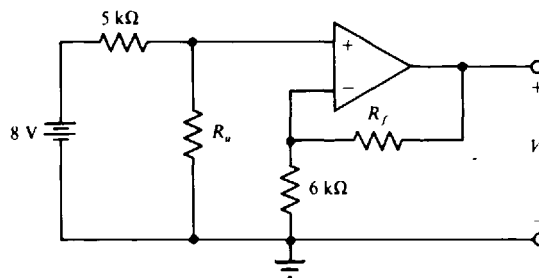

Fig. 6-38

- 6.44** Assume for the op-amp circuit of Fig. 6-38 that $R_a = 10$ k Ω and that the op-amp saturation voltages are $V_o = \pm 13$ V. Determine the range of resistances of R_f that will result in linear operation.

Ans. $0 \Omega \leq R_f \leq 8.625$ k Ω

- 6.45** Obtain the Thévenin equivalent of the circuit of Fig. 6-39 for $V_s = 4$ V and $R_f = 8$ k Ω . Reference V_{Th} positive toward terminal a .

Ans. 5.33 V, 1.33 k Ω

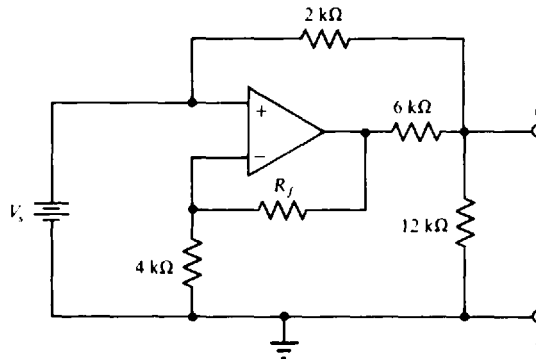

Fig. 6-39

- 6.46** Repeat Prob. 6.45 for $V_s = 5$ V and $R_f = 6$ k Ω .

Ans. 6.11 V, 1.33 k Ω

- 6.47** Calculate V_o in the circuit of Fig. 6-40 with R_f replaced by an open circuit.

Ans. 8 V

- 6.48** Repeat Prob. 6.47 for $R_f = 4$ k Ω .

Ans. -4.8 V

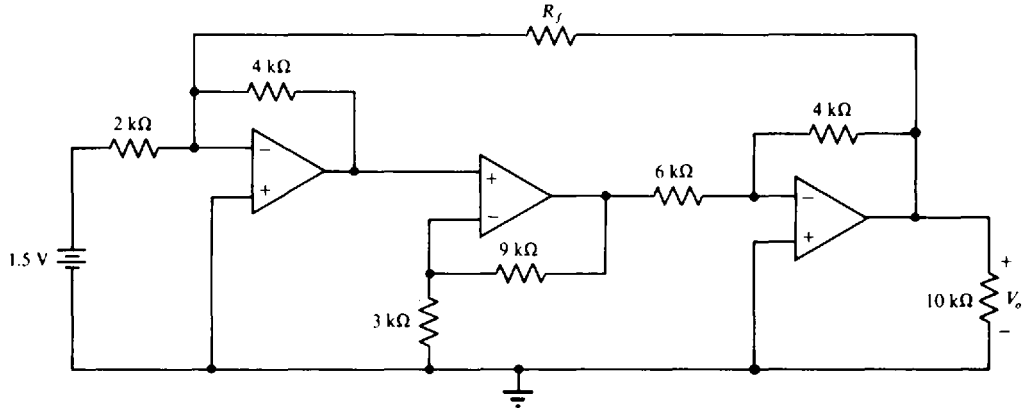

Fig. 6-40

6.49 Calculate V_o in the circuit of Fig. 6-41 for $V_a = 2\text{ V}$ and $V_b = 0\text{ V}$.

Ans. 1.2 V

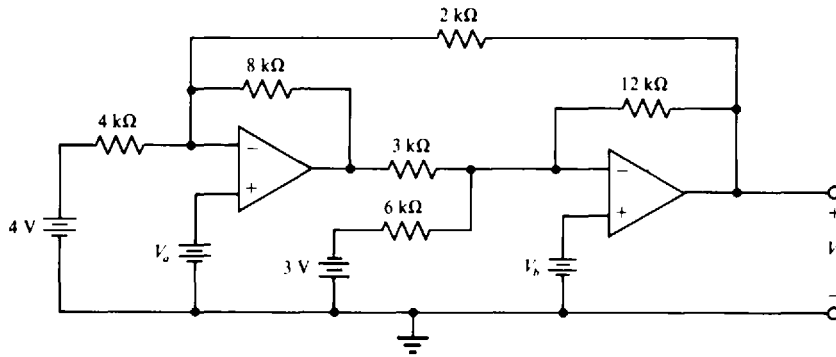

Fig. 6-41

6.50 Repeat Prob. 6.49 for $V_a = 3\text{ V}$ and $V_b = 2\text{ V}$.

Ans. 2.13 V

6.51 Determine V_{1o} and V_{2o} in the circuit of Fig 6-42.

Ans. $V_{1o} = 1.6\text{ V}$, $V_{2o} = 10.5\text{ V}$

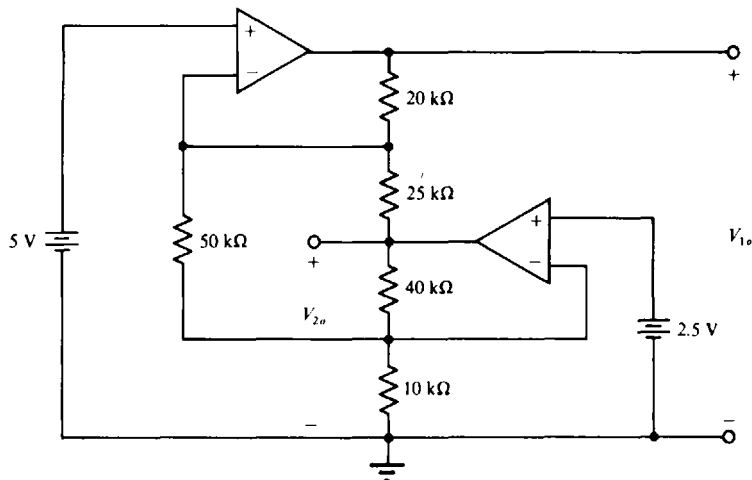

Fig. 6-42

PSpice DC Circuit Analysis

INTRODUCTION

PSpice, from MicroSim Corporation, is a computer program that can be used on many personal computers (PCs) for the analyses of electric circuits. PSpice is a derivative of SPICE which is a circuit simulation program that was developed in the 1970s at the University of California at Berkeley. SPICE is an acronym for *Simulation Program with Integrated Circuit Emphasis*. PSpice was the first derivative of SPICE that was suitable for use on PCs. PSpice and SPICE, which are similar in use, are both used extensively in industry. There are various versions of each.

Principally, only the creation of a PSpice circuit file (also called source file) is presented in this chapter. (But much of this material applies as well to the creation of a SPICE circuit file.) This creation requires the use of a text editor. Typically there are two text editors that can be used, one of which is in what is called the *PSpice Control Shell*.

The PSpice Control Shell is a menu system that includes a built-in text editor. The Control Shell can be run by simply typing PS at the DOS prompt (perhaps C:>), and then pressing the Enter key. After a few seconds, a menu appears. Menu items can be selected by using either the keyboard, mouse, or arrow keys to move horizontally and vertically within the menus. Running PSpice interactively using the Control Shell requires some study, at least for most PSpice users. The MicroSim Corporation has a *User's Guide* that includes an explanation of the Control Shell, among many other features. And there are circuit analysis textbooks that explain its use. But no explanation will be given here.

Instead of editing via the Control Shell, some PSpice users may prefer to use an ASCII text editor, assuming one has been installed to be accessed from PSpice. In this case, the first step to utilizing PSpice might be at the DOS prompt to type CD PSPICE and then press the Enter key to change to the PSpice directory. Then, depending on the particular ASCII text editor, the next step may be to just type ED EEL.CIR and enter it. The ED is the code for edit, and EEL.CIR is the name of the circuit file. Another name such as EE.CIR is as suitable, but the extension .CIR must be included. Now the editing process can be begun and the circuit file created.

After the creation of the circuit file, the computer must be instructed to run the PSpice program with the particular circuit file. If the Control Shell is being used, then the Analysis menu item can be selected for doing this. If it is not being used, then all that is necessary is to type PSPICE followed by the name of the circuit file. The computer then runs the program and places the results in an output file that has the same name as the circuit file except that the extension .OUT replaces the extension .CIR.

Assuming no error notification, the final step is to print the output file. If the Control Shell is being used, this printing can be obtained via the Quit menu item. If it is not being used, then the printout can be obtained by typing PRINT followed by the name of the output file.

BASIC STATEMENTS

A specific PSpice circuit file will be presented before a general consideration of the basic statements. Below is the circuit file for the circuit of Fig. 7-1.

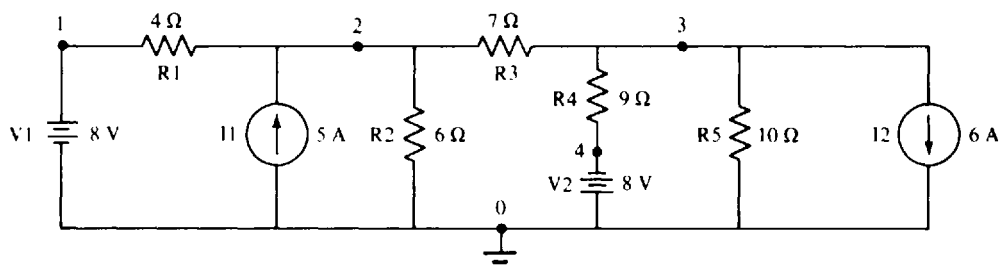

Fig. 7-1

```

CIRCUIT FILE FOR THE CIRCUIT OF FIG. 7-1
V1 1 0 8
R1 1 2 4
I1 0 2 5
R2 2 0 6
R3 2 3 7
R4 3 4 9
V2 0 4 8
R5 3 0 10
I2 3 0 6
.END

```

In this circuit file, the first line, which is called a title line, identifies the circuit being analyzed. The last line is an .END line and is required complete with the period. The lines in between define the circuit, with one component per line. Each of these lines begins with a unique component name, the first letter of which identifies the type of component. Following each name are the numbers of the two nodes between which the component is connected. And following these node numbers is the electrical value of the component.

If PSpice is run with this circuit file, the following appears in the output file:

```

NODE   VOLTAGE      NODE   VOLTAGE      NODE   VOLTAGE      NODE   VOLTAGE
(1)    8.0000     (2)    8.4080     (3)   -16.0690    (4)   -8.0000

VOLTAGE SOURCE CURRENTS
NAME           CURRENT

V1             1.020E-01
V2             8.965E-01

TOTAL POWER DISSIPATION  -7.99E+00  WATTS

```

This printed output includes node voltages and voltage-source currents. The directions of these currents are into the *first specified nodes* of the voltage sources. The specified total power dissipation is the total power provided by the two voltage sources. Since this power is negative, these sources absorb the indicated 7.99 W. The E designates a power of 10, as often does a D in a SPICE output. In a SPICE output, though, the total power dissipation is the net power generated by *all* the independent sources, both voltage and current.

Now consider PSpice circuit file statements in general. The first line in the circuit file must be a title statement. Any comments can be put in this line. For future reference, though, it is a good idea to identify the circuit being analyzed. No other such line is required, but if another is desired, one can be obtained by starting the line with an asterisk (*) in column 1. Although not recommended, the title line can be left blank. But the circuit description (the component lines) cannot start in the first line.

Between the title line and the .END line are the component or element lines, which can be in any order. Each consists of three fields: a name field, a node field, and a value field. Spaces must appear between the fields and also between the node numbers within the node field. The number of spaces is not critical.

In the name field the first letter designates the type of component: R for resistor, V for independent voltage source, and I for independent current source. The letters do not have to be capitalized. Each R, V, or I designator is followed by some label to identify the particular component. A label can consist of letters as well as numbers, with a limit of seven in SPICE.

Each node field comprises two nonnegative integers that identify the two nodes between which the particular circuit component is connected. For a resistor, it does not matter which node label is placed first. For a voltage source, the first node label must be the node at which the voltage source has its positive polarity marking. For a current source, the first node label must be for the node at which the

current *enters* the current source. Note that this node arrangement pertains when positive voltages or currents are specified, as is usual. If negative values are specified, the node arrangement is reversed.

As regards node numbers, there must be a 0 node. This is the node which PSpice considers to be the ground node. The other nodes are preferably identified by positive integers, but these integers need not be sequential.

The value field is simply the value positive or negative of the component in ohms, volts, or amperes, whichever applies. The resistances must be nonzero. Note that the values must not contain commas.

A comment can be inserted in a component line by placing a semicolon after the value field, then the comment is inserted after the semicolon.

As another illustration, consider the circuit of Fig. 7-2. A suitable circuit file is

```
CIRCUIT FILE FOR THE CIRCUIT OF FIG. 7-2
V1  4  0  2E3
R1  4  9  30K
R2  0  9  40MEG
I1  0  9  70M
.END
```

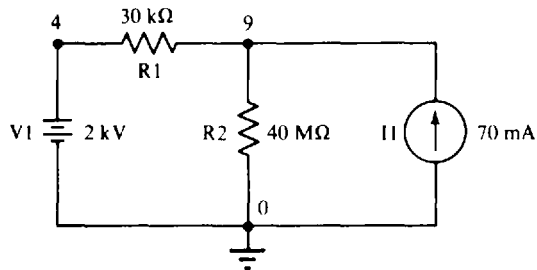

Fig. 7-2

In this circuit file, observe the use of suffix letters in the value field to designate powers of 10. The 2E3 for the V1 statement could as well be 2K. Following is a complete listing of PSpice suffix letters and scale factors.

F	10^{-15}	U	10^{-6}	MEG	10^6
P	10^{-12}	M	10^3	G	10^9
N	10^{-9}	K	10^3	T	10^{12}

These suffix letters do not have to be capitalized; PSpice makes no distinction between uppercase and lowercase letters.

DEPENDENT SOURCES

All four dependent sources are available in PSpice. Their identifiers are E for a voltage-controlled voltage source, F for a current-controlled current source, G for a voltage-controlled current source, and H for a current-controlled voltage source.

For an illustration of dependent source statements, consider the circuit of Fig. 7-3, and the corresponding circuit file below.

In Fig. 7-3 the two “dummy” voltage sources VD1 and VD2, with zero in the value field, are needed because of the PSpice requirement that for a current to be a controlling quantity, it must flow through an independent voltage source. If no such source is present, then a “dummy” voltage source of zero volts must be inserted. The voltage is made zero to avoid affecting the circuit operation. The 0 need not be specified, though, because PSpice will use a default of 0 V.

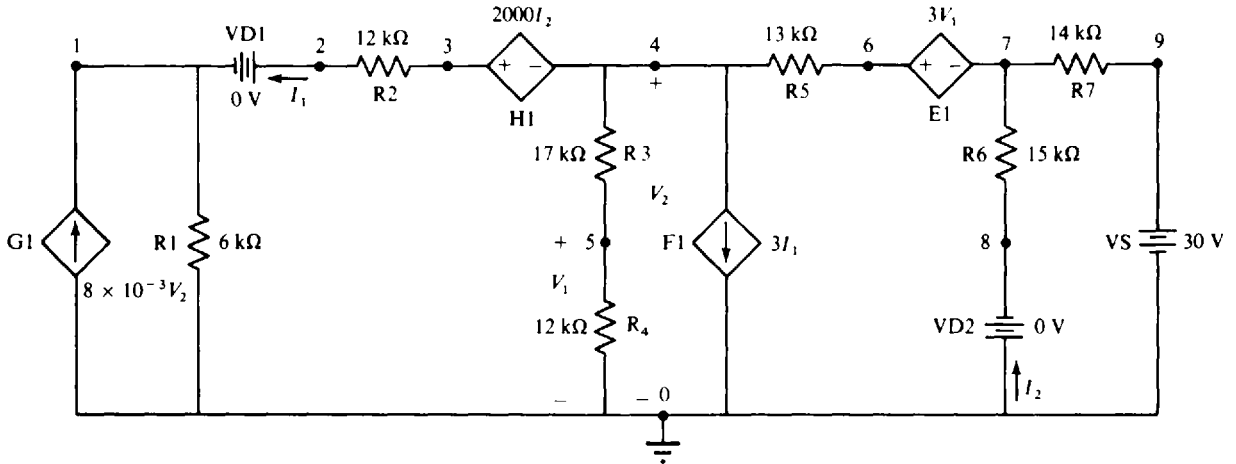

Fig. 7-3

CIRCUIT FILE FOR THE CIRCUIT OF FIG. 7-3

```
G1 0 1 4 0 8M
R1 1 0 6K
VD1 2 1 0
R2 3 2 12K
H1 3 4 VD2 2K
R3 4 5 17K
R4 5 0 12K
F1 4 0 VD1 3
R5 4 6 13K
E1 6 7 5 0 3
R6 8 7 15K
VD2 0 8 0
R7 7 9 14K
VS 9 0 30
.END
```

For each dependent source statement, the first two nodes specified are the nodes between which the dependent source is positioned. Further, the arrangement of these nodes is the same as for an independent source with regard to voltage polarity or current direction.

For a voltage-controlled dependent source, there is a second pair of specified nodes. These are the nodes across which the controlling voltage occurs, with the first node being the node at which the controlling voltage is referenced positive. For a current-controlled dependent source, there is an independent voltage source designator instead of a second pair of nodes. This is the name of the independent voltage source through which the controlling current flows from the first specified node of the voltage source to the second. The last field in each dependent source statement is for the scale factor or multiplier.

PSpice does not have a built-in component for an ideal operational amplifier. From the model shown in Fig. 6-2b, though, it should be apparent that all that is required to effectively obtain an ideal op amp is a single voltage-controlled voltage source with a huge voltage gain, say 500 000 or more. If a nonideal op amp is desired, resistors can be included as shown in Fig. 6-2a.

.DC AND .PRINT CONTROL STATEMENTS

So far, the only voltages and currents obtained have been node voltages and independent voltage source currents. Obtaining others requires the inclusion of a .DC control statement, and also a .PRINT statement in the source file.

If a circuit had, say, a 30-V dc voltage source named V1, a suitable .DC control statement would be

```
.DC V1 30 30 1
```

(V1 was selected for purposes of illustration, but any independent voltage or current source can be used as a .DC control statement.) Note that two value specifications are necessary, which are both 30 here. The reason for having two of them is to allow for a variation in voltage. If, for example, three analyses were desired, one for $V1 = 30$ V, another for $V1 = 35$ V, and a third for $V1 = 40$ V, the statement would be

```
.DC V1 30 40 5
```

where 30 is the first voltage variation, 40 is the last one, and 5 is the voltage increment between the variations.

Now, suppose it is desired to obtain the voltage on node 4 with respect to ground, the voltage across nodes 2 and 3 with node 2 referenced positive, the voltage across resistor R6 with the positive reference at the first specified node of that resistor, and the current through resistor R2 with the reference direction of the current being into the first specified node of that resistor. The required .PRINT statement would be

```
.PRINT DC V(4) V(2,3) V(R6) I(R2)
```

When a .PRINT statement is used, only the voltages and currents specified in that statement will appear in the output.

The DC must be included in the .PRINT statement to specify the type of analysis. Further, although optional, a DC specification is often included in each dc independent source statement between the node and value fields as in, for example,

```
V1 3 4 DC 10.
```

With some versions of SPICE, only currents flowing through voltage sources can be specified as in, for example, I(V2). Also, voltages must be specified across nodes and not components.

RESTRICTIONS

PSpice requires a dc path to ground from each node. This is seldom a problem for dc circuits, but must be considered for some other circuits, as will be seen. Resistors and voltage sources (and also inductors) provide dc paths, but current sources (and capacitors) do not. A resistor of huge resistance can always be inserted between a node and ground to provide a dc path. The resistance should be large enough that the presence of the resistor does not significantly affect the circuit operation.

Each node must have at least two circuit components connected to it. This restriction poses a slight problem at an open circuit. One simple solution is to insert a resistor of huge resistance across the open circuit.

Finally, PSpice will not allow a loop of voltage sources (or of inductors). The insertion of a resistor in series with one of the voltage sources will eliminate this problem. The resistance should be small enough that the presence of the resistor does not significantly affect the circuit operation.

Solved Problems

7.1 Repeat Prob. 4.11 using PSpice. Specifically, find the mesh currents I_1 and I_2 in the circuit of Fig. 4-14.

Figure 7-4 is Fig. 4-14 (redrawn and labeled for PSpice). Such a circuit will be referred to as a *PSpice circuit*. Following are the corresponding circuit file and the printed output obtained from running PSpice with this circuit file. Observe that $I_1 = I(R1) = -8$ A and $I_2 = I(R3) = 1$ A are in agreement with the answers to Prob. 4.11.

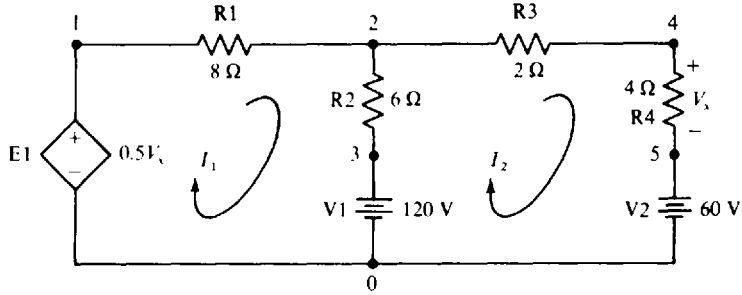

Fig. 7-4

CIRCUIT FILE FOR THE CIRCUIT OF FIG. 7-4

```
E1 1 0 4 5 0.5
R1 1 2 8
R2 2 3 6
V1 3 0 120
R3 2 4 2
R4 4 5 4
V2 5 0 60
.DC V1 120 120 1
.PRINT DC I(R1) I(R3)
.END
```

V1	I(R1)	I(R3)
1.200E+02	-8.000E+00	1.000E+00

7.2 Repeat Prob. 4.15 using PSpice. Specifically, find the power absorbed by the dependent source in the circuit of Fig. 4-19.

Figure 7.5 is the PSpice circuit corresponding to the circuit of Fig. 4-19.

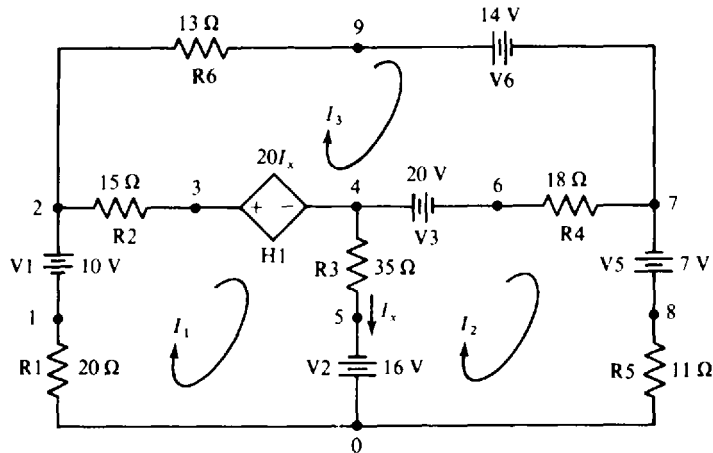

Fig. 7-5

Since PSpice does not provide a power output except for the total power produced by independent voltage sources, the power absorbed by the dependent source must be calculated by hand after PSpice is used to obtain the voltage across the dependent source and the current flowing into the positive terminal of this source.

In the following circuit file, observe in the V2 statement (V2 5 0 -16) that node 5 is the first specified node, which in turn means that the specified voltage must be negative since node 5 is not the

positive node. Node 5 should be the first specified node because the controlling current I_x flows into it. Remember that a controlling current must flow through an independent voltage source.

```

CIRCUIT FILE FOR THE CIRCUIT OF FIG. 7-5
R1  1  0  20
V1  2  1  10
R2  2  3  15
H1  3  4  V2  20
R3  4  5  35
V2  5  0  -16
V3  4  6  20
R4  6  7  18
V5  8  7  7
R5  8  0  11
R6  2  9  13
V6  9  7  14
.DC  V1  10  10  1
.PRINT  DC  V(H1)  I(H1)
.END
*****
      V1          V(H1)          I(H1)
1.000E+01      8.965E+00      -1.080E-01

```

The power absorbed by the dependent source can be obtained from the printed output:

$$P = V(H1) \times I(H1) = 8.965(-0.108) = -0.968 \text{ W}$$

which agrees with the answer to Prob. 4.15.

7.3 Repeat Prob. 4.22 using PSpice. Specifically, determine the current I in the circuit of Fig. 4-25.

Figure 7-6 is the PSpice circuit corresponding to the circuit of Fig. 4-25. This PSpice circuit, though, has an added dummy voltage source VD. It is the current in this source that is the controlling current for the two dependent sources. Again, remember that a controlling current must flow through an independent voltage source.

Below is the corresponding circuit file along with the printed output obtained when this file is run with PSpice. The output $I(R3) = 3 \text{ A}$ agrees with the answer to Prob. 4.22.

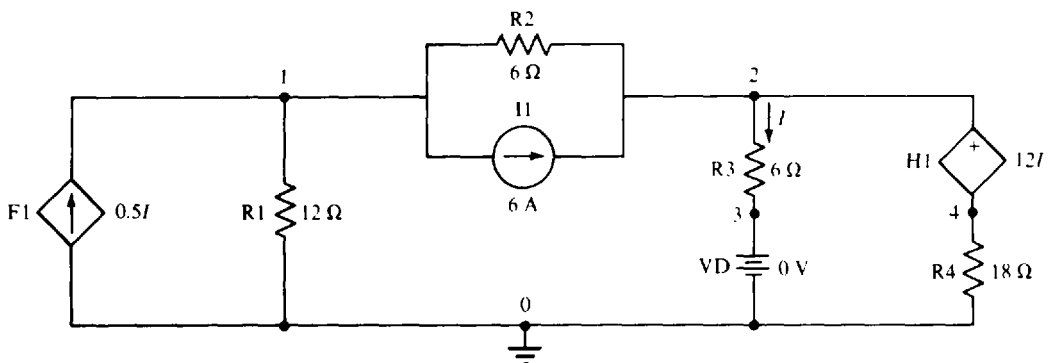

Fig. 7-6

CIRCUIT FILE FOR THE CIRCUIT OF FIG. 7-6

```
F1 0 1 VD 0.5
R1 1 0 12
R2 1 2 6
I1 1 2 6
R3 2 3 6
VD 3 0
H1 2 4 VD 12
R4 4 0 18
.DC I1 6 6 1
.PRINT DC I(R3)
.END
```

```
      I1          I(R3)
6.000E+00    3.000E+00
```

7.4 Repeat Prob. 4.49 using PSpice. Specifically, determine the mesh currents I_1 , I_2 , and I_3 in the circuit of Fig. 4-39.

Figure 7-7 is the PSpice circuit corresponding to the circuit of Fig. 4-39. A dummy voltage source V2 has been included for the controlling current I_x to flow through.

Following is the corresponding circuit file along with the printed output obtained when this file is run with PSpice. The currents $I(R1) = I_1 = -3.260$ mA, $I(R4) = I_2 = -1.989$ mA, and $I(R3) = I_3 = 1.823$ mA agree within three significant digits with the answers to Prob. 4.49.

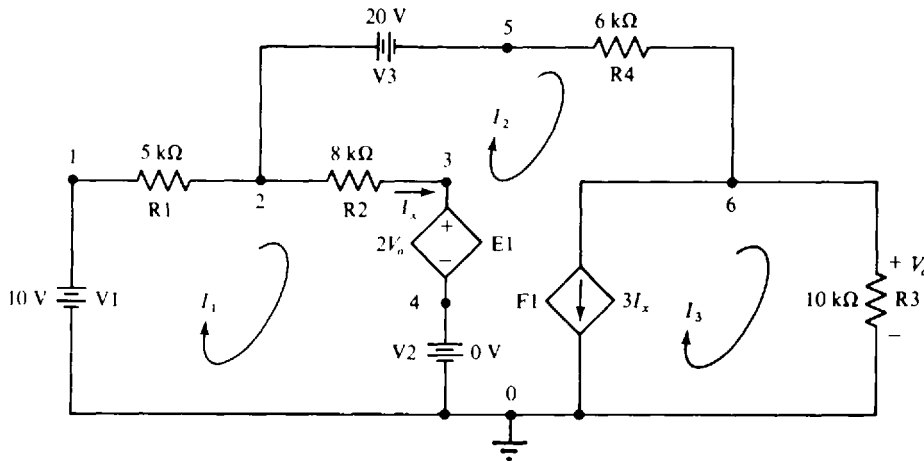

Fig. 7-7

CIRCUIT FILE FOR THE CIRCUIT OF FIG. 7-7

```
V1 1 0 10
R1 1 2 5K
R2 2 3 8K
E1 3 4 6 0 2
V2 4 0
F1 6 0 V2 3
R3 6 0 10K
V3 2 5 20
R4 5 6 6K
.DC V1 10 10 1
.PRINT DC I(R1) I(R4) I(R3)
.END
```

```
      V1          I(R1)          I(R4)          I(R3)
1.000E+01    -3.260E-03    -1.989E-03    1.823E-03
```

7.5 Repeat Prob. 5.11 using PSpice. In other words, obtain the Thévenin equivalent of the circuit of Fig. 5-20a.

Figure 7-8 is the PSpice circuit corresponding to the circuit of Fig. 5-20a. This PSpice circuit has a dummy voltage source V1 inserted for sensing the controlling current I .

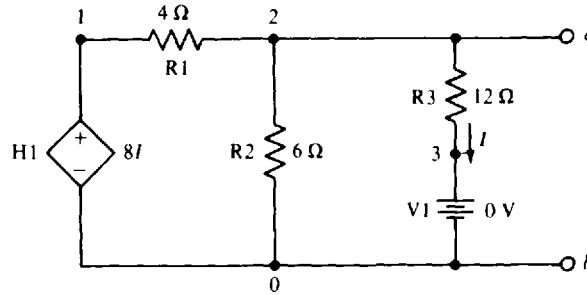

Fig. 7-8

CIRCUIT FILE FOR THE CIRCUIT OF FIG. 7-8

```
H1 1 0 V1 8
R1 1 2 4
R2 2 0 6
R3 2 3 12
V1 3 0
.TF V(2,0) V1
.END
```

NODE	VOLTAGE	NODE	VOLTAGE	NODE	VOLTAGE
(1)	0.0000	(2)	0.0000	(3)	0.0000

**** SMALL-SIGNAL CHARACTERISTICS

V(2,0)/V1 = -2.500E-01

INPUT RESISTANCE AT V1 = 9.600E+00

OUTPUT RESISTANCE AT V(2,0) = 3.000E+00

Above is the corresponding circuit file along with the PSpice output. In the circuit file a .TF statement has been included to obtain the Thévenin resistance. The format of this statement is

```
.TF (output variable) (independent source)
```

The resulting output consists of three parts:

1. The ratio of the output variable to the specified source quantity. For example, in the case in which the independent source provides an input voltage and the output is the output voltage, this ratio is the voltage gain of the circuit.
2. The second is the resistance "seen" by the independent source. It is the ratio of the source voltage to the source current flowing out of the positive source terminal with the other independent sources deactivated. In an electronic circuit, this resistance may be the input resistance.
3. The final output part consists of the output resistance at the terminals of the output variable, and includes the resistance of any resistor connected across these terminals. For the present case, this output resistance is the Thévenin resistance, which is the desired quantity.

The voltage gain and the input resistance parts of the output are not of interest. The printed output resistance of $3\ \Omega$, the Thévenin resistance, agrees with the answer to Prob. 5.11. The Thévenin voltage is zero, of course, as is specified by the printed node 2 voltage.

7.6 Repeat Prob. 5.46 using PSpice. Specifically, obtain the Thévenin equivalent of the circuit of Fig. 5-49 to the left of terminals *a* and *b*.

Figure 7-9 is the PSpice circuit corresponding to the circuit of Fig. 5-49. A resistor R3 has been inserted across the open circuit at terminals *a* and *b* to satisfy the PSpice requirement that at least two components must be connected to each node. However, the resistance of R3 is so large that the presence of this resistor will not significantly affect the circuit operation.

Below is the corresponding circuit file along with the resulting output. A .TF statement has been included in the circuit file to obtain the Thévenin resistance. No .DC or .PRINT statements have been included

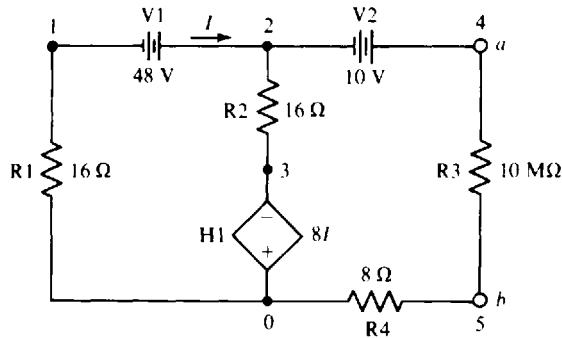

Fig. 7-9

CIRCUIT FILE FOR THE CIRCUIT OF FIG. 7-9

```
R1 1 0 16
V1 1 2 -48
R2 2 3 16
H1 0 3 V1 8
V2 4 2 10
R3 4 5 10MEG
R4 5 0 8
.TF V(4,5) V1
.END
```

NODE	VOLTAGE	NODE	VOLTAGE	NODE	VOLTAGE	NODE	VOLTAGE
(1)	-32.0000	(2)	16.0000	(3)	-16.0000	(4)	26.0000
(5)	20.80E-06						

VOLTAGE SOURCE CURRENTS
NAME CURRENT

V1 2.000E+00
V2 -2.600E-06

TOTAL POWER DISSIPATION 9.60E+01 WATTS

**** SMALL-SIGNAL CHARACTERISTICS

$$V(4,5)/V1 = -3.333E-01$$

$$\text{INPUT RESISTANCE AT V1} = 2.400E+01$$

$$\text{OUTPUT RESISTANCE AT V(4,5)} = 1.867E+01$$

because the node voltages will be printed out automatically. Observe that node voltage 4 is essentially the same as the voltage across terminals 4 and 5, the Thévenin voltage, because the voltage drop across resistor R4 is negligible. The obtained node 4 voltage value of 26 V and the output resistance value of 18.67 Ω, which are the Thévenin quantities, agree with the answers to Prob. 5.46.

7.7 Repeat the first part of Prob. 6.13 using PSpice. Specifically, compute V_o in the circuit of Fig. 6-18.

Figure 6-18 is redrawn in Fig. 7-10a, for convenience. Figure 7-10b shows the corresponding PSpice circuit. Observe that the op amp has been deleted, and a model for it included. This model E1 is simply a voltage-controlled voltage source connected across the terminals that were the op-amp output terminals. The 10^6 voltage gain of this source is not critical.

Following is the corresponding circuit file along with the pertinent part of the output obtained when PSpice is run with this circuit file. Here, $V_o = V(4) = -10\text{ V}$, which is the same as the answer to the first part of Prob. 6.13.

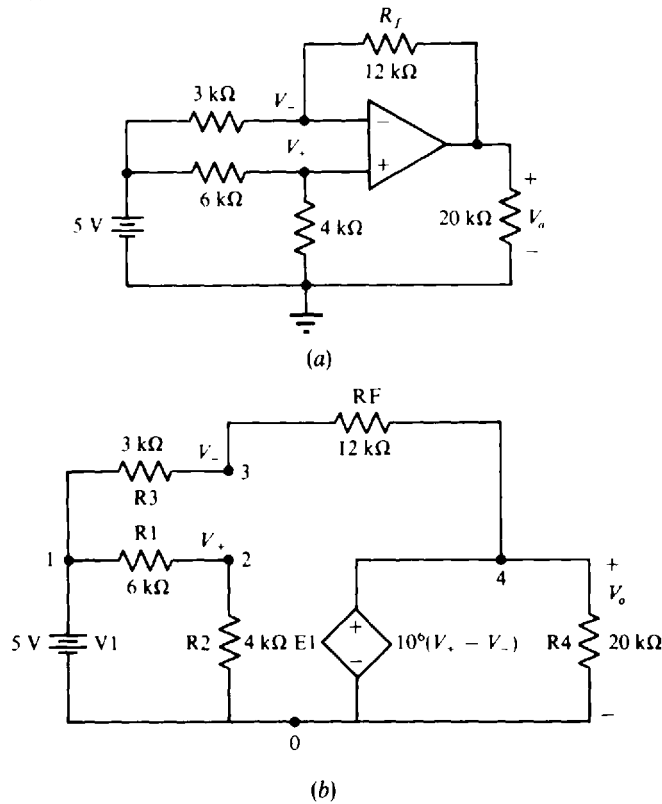

Fig. 7-10

CIRCUIT FILE FOR THE CIRCUIT OF FIG. 7-10b

```
V1 1 0 5
R1 1 2 6K
R2 2 0 4K
R3 1 3 3K
RF 3 4 12K
R4 4 0 20K
E1 4 0 2 3 1MEG
.END
```

```
*****
NODE   VOLTAGE   NODE   VOLTAGE   NODE   VOLTAGE   NODE   VOLTAGE
(1)    5.0000   (2)    2.0000   (3)    2.0000   (4)    -10.0000
```

7.8 Repeat Prob. 6.20 using PSpice. Specifically, obtain the Thévenin equivalent of the circuit of Fig. 6-24.

Figure 7-11a is the same as Fig. 6-24, and is included here for convenience. Figure 7-11b is the corresponding PSpice circuit in which the op amp has been replaced by a model E1 that is a voltage-controlled voltage source.

Below is the corresponding circuit file along with the pertinent portion of the output file. Node voltage $V(3) = 3\text{ V}$ is the Thévenin voltage, and the output resistance of $571.4\ \Omega$ is the Thévenin resistance. Both values agree with the answers to Prob. 6.20.

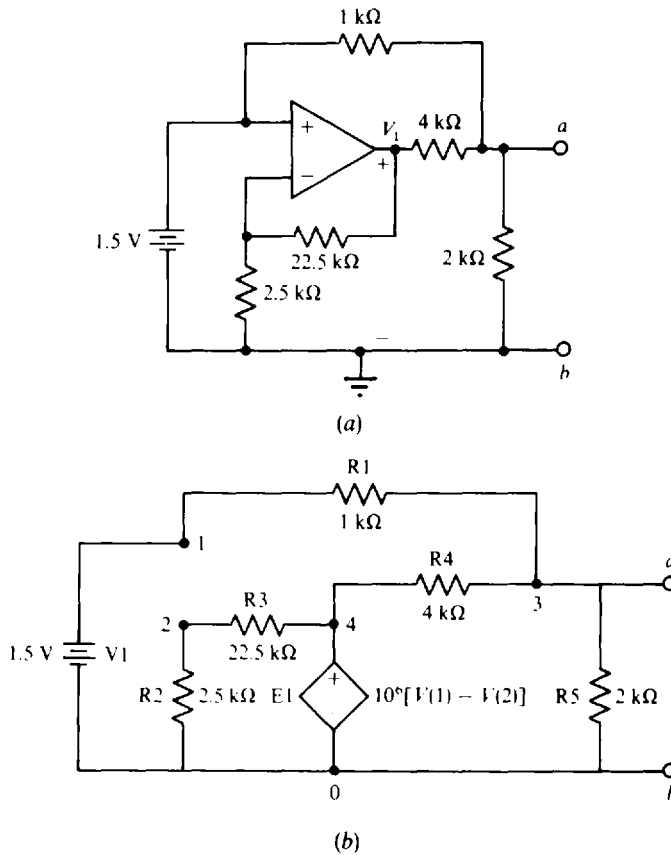

Fig. 7-11

CIRCUIT FILE FOR FIG. 7-11b

```
V1 1 0 1.5
R1 1 3 1K
R2 2 0 2.5K
R3 2 4 22.5K
E1 4 0 1 2 1MEG
R4 4 3 4K
R5 3 0 2K
.TF V(3) V1
.END
```

NODE	VOLTAGE	NODE	VOLTAGE	NODE	VOLTAGE	NODE	VOLTAGE
(1)	1.5000	(2)	1.5000	(3)	3.0000	(4)	15.0000

OUTPUT RESISTANCE AT V(3) = 5.714E+02

7.9 Repeat Prob. 6.24 using PSpice. Specifically, obtain the voltages V_{1o} and V_{2o} in the circuit of Fig. 6-28.

Figure 7-12a is the same as Fig. 6-28 and is included solely for convenience. Figure 7-12b is the corresponding PSpice circuit in which the two op amps have been replaced by models E1 and E2, which are voltage-controlled voltage sources.

Following is the corresponding circuit file and the pertinent part of the output file. The results of $V(3) = V_{1o} = 12.5 \text{ V}$ and $V(4) = V_{2o} = 1 \text{ V}$ agree with the answers to Prob. 6.24.

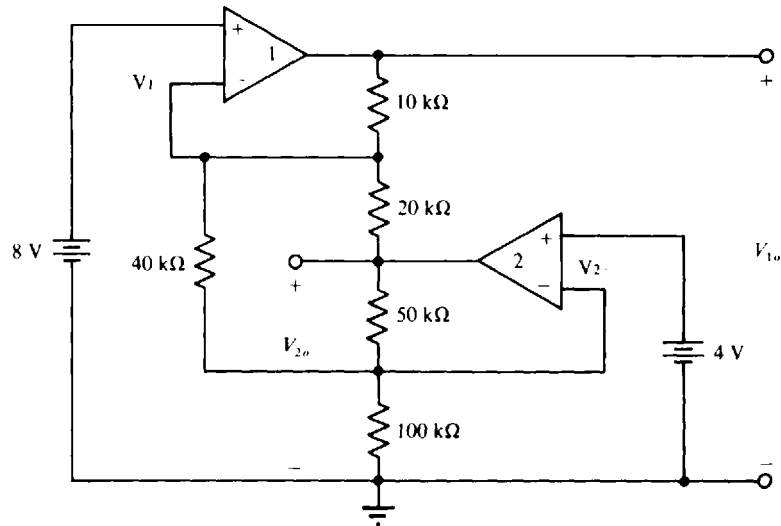

(a)

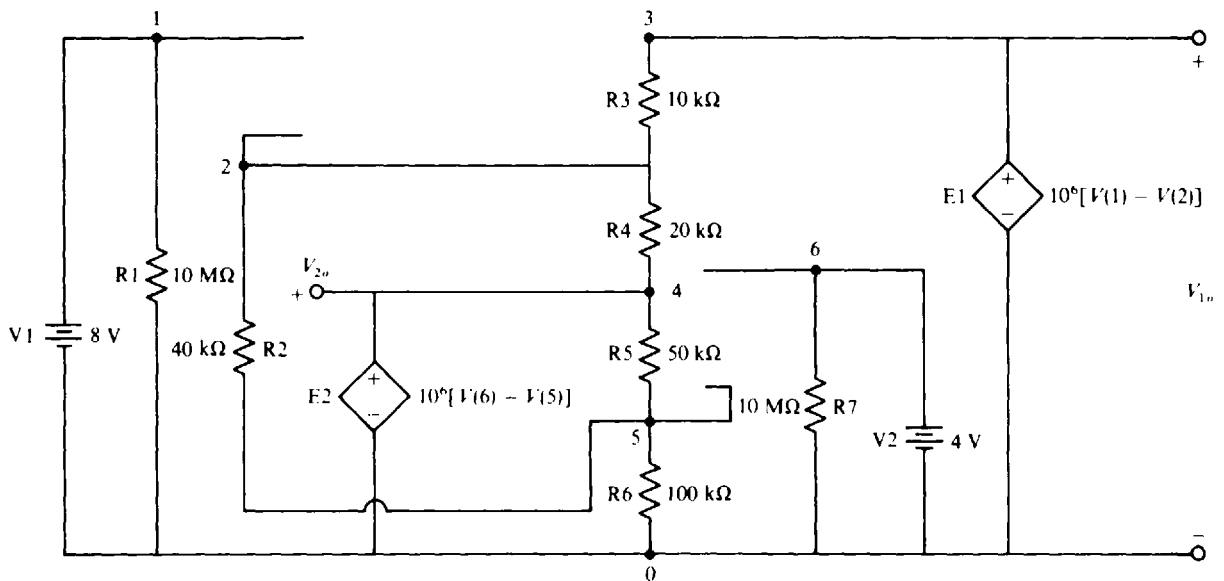

(b)

Fig. 7-12

```

CIRCUIT FILE FOR THE CIRCUIT OF FIG. 7-12b
V1  1 0  8
R1  1 0 10MEG
R2  2 5  40K
R3  3 2  10K
R4  2 4  20K
R5  4 5  50K
R6  5 0 100K
R7  6 0 10MEG
V2  6 0  4
E1  3 0  1 2 1MEG
E2  4 0  6 5 1MEG
.END
    
```

NODE	VOLTAGE	NODE	VOLTAGE	NODE	VOLTAGE	NODE	VOLTAGE
(1)	8.0000	(2)	8.0000	(3)	12.5000	(4)	1.0000
(5)	4.0000	(6)	4.0000				

Supplementary Problems

- 7.10 Use PSpice to compute I_x in the circuit of Fig. 4-28.
Ans. -0.333 A
- 7.11 Use PSpice to determine I in the circuit of Fig. 4-45.
Ans. -3.53 mA
- 7.12 Use PSpice to find the Thévenin voltage at terminals a and b in the circuit of Fig. 5-44. Reference V_{Th} positive at terminal a .
Ans. 143.3 V
- 7.13 Use PSpice to obtain V_o in the circuit of Fig. 6-21.
Ans. 10 V
- 7.14 Use PSpice to find V_o in the circuit of Fig. 6-22.
Ans. -1.95 V
- 7.15 Use PSpice to determine V_{1o} and V_{2o} in the circuit of Fig. 6-42.
Ans. $1.6\text{ V}, 10.5\text{ V}$
- 7.16 Without using PSpice, determine the output corresponding to the following circuit file.

```

CIRCUIT FILE FOR PROB. 7.16
V1  1 0  12
R1  1 2  2
R2  2 3  3
V2  3 0  10
R3  2 4  4
V3  0 4  20
.DC V1 12 12 1
.PRINT DC I(R1)
.END
    
```

Ans. 4 A

- 7.17 Without using PSpice, determine the output corresponding to the following circuit file.

```
CIRCUIT FILE FOR PROB. 7.17
V1 1 0 27
R1 1 2 3
R2 2 3 4
V2 3 0 29
R3 2 4 5
R4 4 5 6
V3 0 5 53
I1 0 4 5
.DC V1 27 27 1
.PRINT DC I(R3)
.END
```

Ans. 4 A

- 7.18 Without using PSpice, determine the output corresponding to the following circuit file.

```
CIRCUIT FILE FOR PROB. 7.18
V1 1 0 45
R1 1 2 3
R2 2 3 2
R3 3 0 4
R4 2 0 2.4
G1 0 2 2 3 0.25
.DC V1 45 45 1
.PRINT DC V(R2)
.END
```

Ans. 6 V

- 7.19 Without using PSpice, determine the output corresponding to the following circuit file.

```
CIRCUIT FILE FOR PROB. 7.19
I1 0 1 4
R1 1 2 5
V1 2 0
R2 1 0 20
H1 3 1 V1 5
R3 3 0 8
.DC I1 4 4 1
.PRINT DC I(R1)
.END
```

Ans. 1.6 A

- 7.20 Without using PSpice, determine the output corresponding to the following circuit file.

```
CIRCUIT FILE FOR PROB. 7.20
F1 0 1 V1 0.5
R1 1 0 6
R2 1 2 3
I1 1 2 6
R3 2 3 9
H1 3 0 V1 6
V1 2 4
R4 4 0 3
.DC I1 6 6 1
.PRINT DC I(R4)
.END
```

Ans. 3 A

7.21 Without using PSpice, determine the output corresponding to the following circuit file.

```
CIRCUIT FILE FOR PROB. 7.21
V1 1 0 20
R1 1 2 6K
R2 2 3 3K
V2 3 4 40
R3 4 5 2K
V3 5 0 60
R4 4 6 8K
V4 7 6 30
R5 7 8 5K
V5 0 8 45
R6 2 9 9K
V6 9 7 15
.DC V1 20 20 1
.PRINT DC I(R4) I(R3) I(R5)
.END
```

Ans. $I(R4) = 6.95 \text{ mA}$, $I(R3) = -14.6 \text{ mA}$, $I(R5) = 10.0 \text{ mA}$

7.22 Without using PSpice, determine the output corresponding to the following circuit file.

```
CIRCUIT FILE FOR PROB. 7.22
I1 0 1 60
R1 1 0 0.14286
R2 1 2 0.2
I2 2 1 22
I3 2 0 34
R3 2 0 0.25
R4 2 3 0.16667
R5 3 0 0.16667
R6 1 3 0.125
.DC I1 60 60 1
.PRINT DC V(2)
.END
```

Ans. -2 V

7.23 Without using PSpice, determine the output corresponding to the following circuit file. (*Hint*: Consider an op-amp circuit.)

```
CIRCUIT FILE FOR PROB. 7.23
V1 1 0 6
R1 1 2 4K
V2 0 3 15
R2 3 2 6K
R3 2 4 12K
E1 4 0 0 2 1MEG
.DC V1 6 6 1
.PRINT DC V(4)
.END
```

Ans. 12 V

- 7.24 Without using PSpice, determine the output corresponding to the following circuit file. (*Hint*: Consider an op-amp circuit.)

```
CIRCUIT FILE FOR PROB. 7.24
V1 1 0 9
R1 1 2 9K
R2 2 0 18K
R3 2 3 12K
R4 4 0 6K
R5 4 3 3K
E1 3 0 2 4 1MEG
.DC V1 9 9 1
.PRINT DC V(3)
.END
```

Ans. 12 V

Capacitors and Capacitance

INTRODUCTION

A *capacitor* consists of two conductors separated by an insulator. The chief feature of a capacitor is its ability to store electric charge, with negative charge on one of its two conductors and positive charge on the other. Accompanying this charge is energy, which a capacitor can release. Figure 8-1 shows the circuit symbol for a capacitor

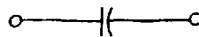

Fig. 8-1

CAPACITANCE

Capacitance, the electrical property of capacitors, is a measure of the ability of a capacitor to store charge on its two conductors. Specifically, if the potential difference between the two conductors is V volts when there is a positive charge of Q coulombs on one conductor and a negative charge of the same amount on the other, the capacitor has a capacitance of

$$C = \frac{Q}{V}$$

where C is the quantity symbol of capacitance.

The SI unit of capacitance is the *farad*, with symbol F. Unfortunately, the farad is much too large a unit for practical applications, and the microfarad (μF) and picofarad (pF) are much more common.

CAPACITOR CONSTRUCTION

One common type of capacitor is the parallel-plate capacitor of Fig. 8-2a. This capacitor has two spaced conducting plates that can be rectangular, as shown, but that often are circular. The insulator between the plates is called a *dielectric*. The dielectric is air in Fig. 8-2a, and is a slab of solid insulator in Fig. 8-2b.

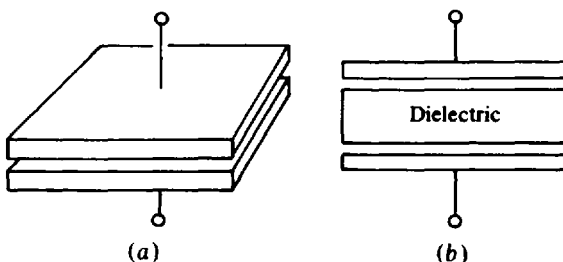

Fig. 8-2

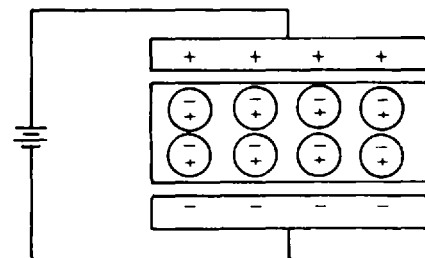

Fig. 8-3

A voltage source connected to a capacitor, as shown in Fig. 8-3, causes the capacitor to become charged. Electrons from the top plate are attracted to the positive terminal of the source, and they pass through the source to the negative terminal where they are repelled to the bottom plate. Because each electron lost by the top plate is gained by the bottom plate, the magnitude of charge Q is the same on

both plates. Of course, the voltage across the capacitor from this charge exactly equals the source voltage. The voltage source did work on the electrons in moving them to the bottom plate, which work becomes energy stored in the capacitor.

For the parallel-plate capacitor, the capacitance in farads is

$$C = \epsilon \frac{A}{d}$$

where A is the area of either plate in square meters, d is the separation in meters, and ϵ is the *permittivity* in farads per meter (F/m) of the dielectric. The larger the plate area or the smaller the plate separation, or the greater the dielectric permittivity, the greater the capacitance.

The permittivity ϵ relates to atomic effects in the dielectric. As shown in Fig. 8-3, the charges on the capacitor plates distort the dielectric atoms, with the result that there is a net negative charge on the top dielectric surface and a net positive charge on the bottom dielectric surface. This dielectric charge partially neutralizes the effects of the stored charge to permit an increase in charge for the same voltage.

The permittivity of vacuum, designated by ϵ_0 , is 8.85 pF m. Permittivities of other dielectrics are related to that of vacuum by a factor called the *dielectric constant* or *relative permittivity*, designated by ϵ_r . The relation is $\epsilon = \epsilon_r \epsilon_0$. The dielectric constants of some common dielectrics are 1.0006 for air, 2.5 for paraffined paper, 5 for mica, 7.5 for glass, and 7500 for ceramic.

TOTAL CAPACITANCE

The total or equivalent capacitance (C_T or C_{eq}) of parallel capacitors, as seen in Fig. 8-4a, can be found from the total stored charge and the $Q = CV$ formula. The total stored charge Q_T equals the sum of the individual stored charges: $Q_T = Q_1 + Q_2 + Q_3$. With the substitution of the appropriate $Q = CV$ for each Q , this equation becomes $C_T V = C_1 V + C_2 V + C_3 V$. Upon division by V , it reduces to $C_T = C_1 + C_2 + C_3$. Because the number of capacitors is not significant in this derivation, this result can be generalized to any number of parallel capacitors:

$$C_T = C_1 + C_2 + C_3 + C_4 + \dots$$

So, the total or equivalent capacitance of parallel capacitors is the sum of the individual capacitances.

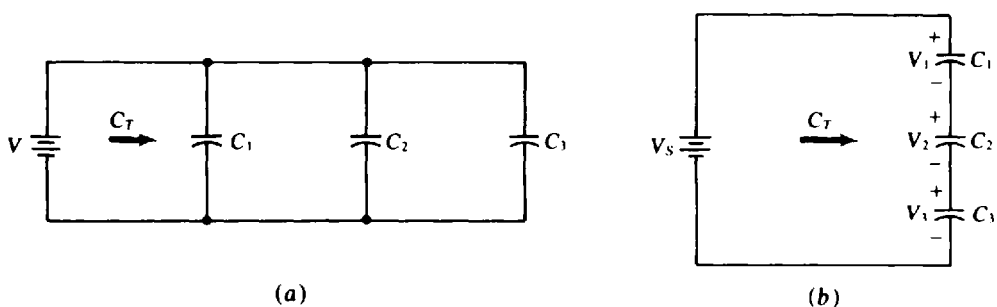

Fig. 8-4

For series capacitors, as shown in Fig. 8-4b, the formula for the total capacitance is derived by substituting Q/C for each V in the KVL equation. The Q in each term is the same. This is because the charge gained by a plate of any capacitor must have come from a plate of an adjacent capacitor. The KVL equation for the circuit shown in Fig. 8-4b is $V_S = V_1 + V_2 + V_3$. With the substitution of the appropriate Q/C for each V , this equation becomes

$$\frac{Q}{C_T} = \frac{Q}{C_1} + \frac{Q}{C_2} + \frac{Q}{C_3} \quad \text{or} \quad \frac{1}{C_T} = \frac{1}{C_1} + \frac{1}{C_2} + \frac{1}{C_3}$$

upon division by Q . This can also be written as

$$C_T = \frac{1}{\frac{1}{C_1} + \frac{1}{C_2} + \frac{1}{C_3}}$$

Generalizing,

$$C_T = \frac{1}{\frac{1}{C_1} + \frac{1}{C_2} + \frac{1}{C_3} + \frac{1}{C_4} + \dots}$$

which specifies that the total capacitance of series capacitors equals the reciprocal of the sum of the reciprocals of the individual capacitances. Notice that the total capacitance of series capacitors is found in the same way as the total resistance of parallel resistors.

For the special case of N series capacitors having the same capacitance C , this formula simplifies to $C_T = C/N$. And for two capacitors in series it is $C_T = C_1 C_2 / (C_1 + C_2)$.

ENERGY STORAGE

As can be shown using calculus, the energy stored in a capacitor is

$$W_C = \frac{1}{2} CV^2$$

where W_C is in joules, C is in farads, and V is in volts. Notice that this stored energy does not depend on the capacitor current.

TIME-VARYING VOLTAGES AND CURRENTS

In dc resistor circuits, the currents and voltages are constant—never varying. Even if switches are included, a switching operation can, at most, cause a voltage or current to jump from one constant level to another. (The term “jump” means a change from one value to another in zero time.) When capacitors are included, though, almost never does a voltage or a current jump from one constant level to another when switches open or close. Some voltages or currents may initially jump at switching, but the jumps are almost never to final values. Instead, they are to values from which the voltages or currents change *exponentially* to their final values. These voltages and currents vary with time—they are *time-varying*.

Quantity symbols for time-varying quantities are distinguished from those for constant quantities by the use of lowercase letters instead of uppercase letters. For example, v and i are the quantity symbols for time-varying voltages and currents. Sometimes, the lowercase t , for time, is shown as an argument with lowercase quantity symbols as in $v(t)$ and $i(t)$. Numerical values of v and i are called *instantaneous values*, or *instantaneous voltages* and *currents*, because these values depend on (vary with) exact instants of time.

As explained in Chap. 1, a constant current is the quotient of the charge Q passing a point in a wire and the time T required for this charge to pass: $I = Q/T$. The specific time T is not important because the charge in a resistive dc circuit flows at a steady rate. This means that doubling the time T doubles the charge Q , tripling the time triples the charge, and so on, keeping I the same.

For a time-varying current, though, the value of i usually changes from instant to instant. So, finding the current at any particular time requires using a very short time interval Δt . If Δq is the small charge that flows during this time interval, then the current is approximately $\Delta q / \Delta t$. For an exact value of current, this quotient must be found in the limit as Δt approaches zero ($\Delta t \rightarrow 0$):

$$i = \lim_{\Delta t \rightarrow 0} \frac{\Delta q}{\Delta t} = \frac{dq}{dt}$$

This limit, designated by dq/dt , is called the *derivative* of charge with respect to time.

CAPACITOR CURRENT

An equation for capacitor current can be found by substituting $q = Cv$ into $i = dq/dt$:

$$i = \frac{dq}{dt} = \frac{d}{dt}(Cv)$$

But C is a constant, and a constant can be factored from a derivative. The result is

$$i = C \frac{dv}{dt}$$

with associated references assumed. If the references are not associated, a negative sign must be included. This equation specifies that the capacitor current at any time equals the product of the capacitance and the time rate of change of voltage at that time. But the current does *not* depend on the value of voltage at that time.

If a capacitor voltage is constant, then the voltage is not changing and so dv/dt is zero, making the capacitor current zero. Of course, from physical considerations, if a capacitor voltage is constant, no charge can be entering or leaving the capacitor, which means that the capacitor current is zero. With a voltage across it and zero current flow through it, the capacitor acts as an open circuit: *a capacitor is an open circuit to dc*. Remember, though, it is only after a capacitor voltage becomes constant that the capacitor acts as an open circuit. Capacitors are often used in electronic circuits to block dc currents and voltages.

Another important fact from $i = C dv/dt$ or $i \simeq C\Delta v/\Delta t$ is that *a capacitor voltage cannot jump*. If, for example, a capacitor voltage could jump from 3 V to 5 V or, in other words, change by 2 V in zero time, then Δv would be 2 and Δt would be 0, with the result that the capacitor current would be infinite. An infinite current is impossible because no source can deliver this current. Further, such a current flowing through a resistor would produce an infinite power loss, and there are no sources of infinite power and no resistors that can absorb such power. Capacitor current has no similar restriction. It can jump or even change directions, instantaneously. Capacitor voltage not jumping means that a capacitor voltage immediately after a switching operation is the same as immediately before the operation. This is an important fact for resistor-capacitor (RC) circuit analysis.

SINGLE-CAPACITOR DC-EXCITED CIRCUITS

When switches open or close in a dc RC circuit with a single capacitor, all voltages and currents that change do so exponentially from their initial values to their final constant values, as can be shown from differential equations. The exponential terms in a voltage or current expression are called *transient terms* because they eventually become zero in practical circuits.

Figure 8-5 shows these exponential changes for a switching operation at $t = 0$ s. In Fig. 8-5a the initial value is greater than the final value, and in Fig. 8-5b the final value is greater. Although both initial and final values are shown as positive, both can be negative or one can be positive and the other negative.

The voltages and currents approach their final values asymptotically, graphically speaking, which means that they never actually reach them. As a practical matter, however, after five time constants (defined next) they are close enough to their final values to be considered to be at them.

Time constant, with symbol τ , is a measure of the time required for certain changes in voltages and currents. For a single-capacitor RC circuit, the time constant of the circuit is the product of the capacitance and the Thévenin resistance as “seen” by the capacitor:

$$RC \text{ time constant} = \tau = R_{Th}C$$

The expressions for the voltages and currents shown in Fig. 8-5 are

$$v(t) = v(\infty) + [v(0+) - v(\infty)]e^{-t/\tau} \text{ V}$$

$$i(t) = i(\infty) + [i(0+) - i(\infty)]e^{-t/\tau} \text{ A}$$

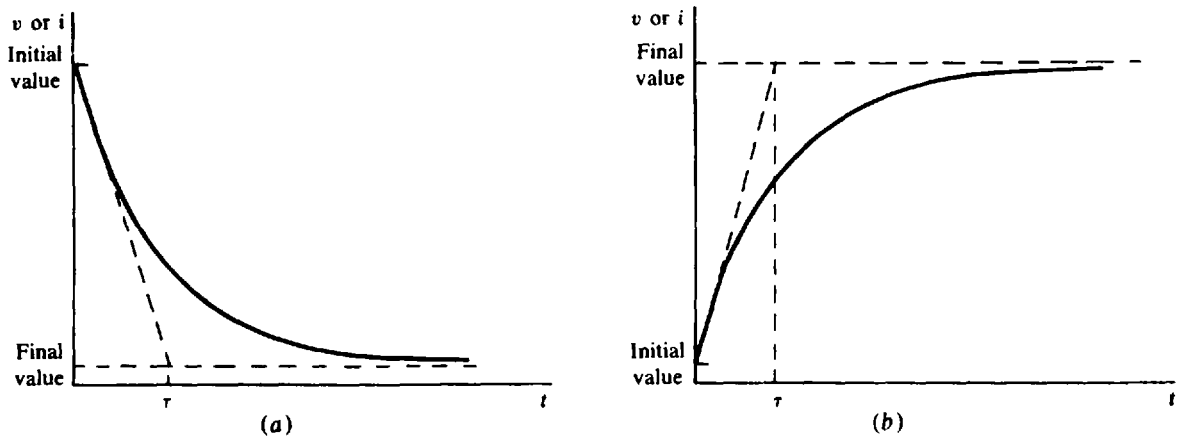

Fig. 8-5

for all time greater than zero ($t > 0$ s). In these equations, $v(0+)$ and $i(0+)$ are initial values immediately after switching; $v(\infty)$ and $i(\infty)$ are final values; $e = 2.718$, the base of natural logarithms; and τ is the time constant of the circuit of interest. These equations apply to all voltages and currents in a linear, RC , single-capacitor circuit in which the independent sources, if any, are all dc.

By letting $t = \tau$ in these equations, it is easy to see that, in a time equal to one time constant, the voltages and currents change by 63.2 percent of their total change of $v(\infty) - v(0+)$ or $i(\infty) - i(0+)$. And by letting $t = 5\tau$, it is easy to see that, after five time constants, the voltages and currents change by 99.3 percent of their total change, and so can be considered to be at their final values for most practical purposes.

RC TIMERS AND OSCILLATORS

An important use for capacitors is in circuits for measuring time *timers*. A simple timer consists of a switch, capacitor, resistor, and dc voltage source, all in series. At the beginning of a time interval to be measured, the switch is closed to cause the capacitor to start charging. At the end of the time interval, the switch is opened to stop the charging and "trap" the capacitor charge. The corresponding capacitor voltage is a measure of the time interval. A voltmeter connected across the capacitor can have a scale calibrated in time to give a direct time measurement.

As indicated in Fig. 8-5, for times much less than one time constant, the capacitor voltage changes almost linearly. Further, the capacitor voltage would get to its final value in one time constant if the rate of change were constant at its initial value. This linear change approximation is valid if the time to be measured is one-tenth or less of a time constant, or, what amounts to the same thing, if the voltage change during the time interval is one-tenth or less of the difference between the initial and final voltages.

A timing circuit can be used with a gas tube to make an *oscillator*—a circuit that produces a repeating waveform. A gas tube has a very large resistance—approximately an open circuit—for small voltages. But at a certain voltage it will fire or, in other words, conduct and have a very low resistance—approximately a short circuit for some purposes. After beginning to conduct, it will continue to conduct even if its voltage drops, provided that this voltage does not drop below a certain low voltage at which the tube stops firing (extinguishes) and becomes an open circuit again.

The circuit illustrated in Fig. 8-6a is an oscillator for producing a sawtooth capacitor voltage as shown in Fig. 8-6b. If the firing voltage V_F of the gas tube is one-tenth or less of the source voltage V_S , the capacitor voltage increases almost linearly, as shown in Fig. 8-6b, to the voltage V_F , at which time T the gas tube fires. If the resistance of the conducting gas tube is small and much less than that of the resistor R , the capacitor rapidly discharges through the tube until the capacitor voltage drops to V_E , the

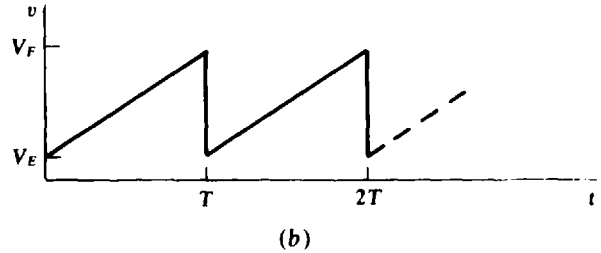
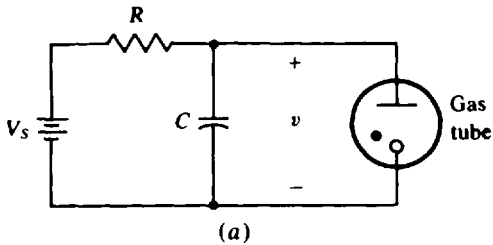

Fig. 8-6

extinguishing voltage, which is not great enough to keep the tube conducting. Then the tube cuts off, the capacitor starts charging again, and the process keeps repeating indefinitely. The time T for one charging and discharging cycle is called a *period*.

Solved Problems

- 8.1** Find the capacitance of an initially uncharged capacitor for which the movement of 3×10^{15} electrons from one capacitor plate to another produces a 200-V capacitor voltage.

From the basic capacitor formula $C = Q/V$, in which Q is in coulombs,

$$C = \frac{-3 \times 10^{15} \text{ electrons}}{200 \text{ V}} \times \frac{-1 \text{ C}}{6.241 \times 10^{18} \text{ electrons}} = 2.4 \times 10^{-6} \text{ F} = 2.4 \mu\text{F}$$

- 8.2** What is the charge stored on a $2\text{-}\mu\text{F}$ capacitor with 10 V across it?

From $C = Q/V$,

$$Q = CV = (2 \times 10^{-6})(10) \text{ C} = 20 \mu\text{C}$$

- 8.3** What is the change of voltage produced by 8×10^9 electrons moving from one plate to the other of an initially charged 10-pF capacitor?

Since $C = Q/V$ is a linear relation, C also relates changes in charge and voltage: $C = \Delta Q/\Delta V$. In this equation, ΔQ is the change in stored charge and ΔV is the accompanying change in voltage. From this,

$$\Delta V = \frac{\Delta Q}{C} = \frac{-8 \times 10^9 \text{ electrons}}{10 \times 10^{-12} \text{ F}} \times \frac{-1 \text{ C}}{6.241 \times 10^{18} \text{ electrons}} = 128 \text{ V}$$

- 8.4** Find the capacitance of a parallel-plate capacitor if the dimensions of each rectangular plate is 1 by 0.5 cm and the distance between plates is 0.1 mm. The dielectric is air. Also, find the capacitance if the dielectric is mica instead of air.

The dielectric constant of air is so close to 1 that the permittivity of vacuum can be used for that of air in the parallel-plate capacitor formula:

$$C = \epsilon \frac{A}{d} = \frac{(8.85 \times 10^{-12})(10^{-2})(0.5 \times 10^{-2})}{0.1 \times 10^{-3}} \text{ F} = 4.43 \text{ pF}$$

Because the dielectric constant of mica is 5, a mica dielectric increases the capacitance by a factor of 5: $C = 5 \times 4.43 = 22.1 \text{ pF}$.

- 8.5** Find the distance between the plates of a $0.01\text{-}\mu\text{F}$ parallel-plate capacitor if the area of each plate is 0.07 m^2 and the dielectric is glass.

From rearranging $C = \epsilon A/d$ and using 7.5 for the dielectric constant of glass,

$$d = \frac{\epsilon A}{C} = \frac{7.5(8.85 \times 10^{-12})(0.07)}{0.01 \times 10^{-6}} \text{ m} = 0.465 \text{ mm}$$

- 8.6** A capacitor has a disk-shaped dielectric of ceramic that has a 0.5-cm diameter and is 0.521 mm thick. The disk is coated on both sides with silver, this coating being the plates. Find the capacitance.

With the ceramic dielectric constant of 7500 in the parallel-plate capacitor formula,

$$C = \epsilon \frac{A}{d} = \frac{7500(8.85 \times 10^{-12})[\pi \times (0.25 \times 10^{-2})^2]}{0.521 \times 10^{-3}} \text{ F} = 2500 \text{ pF}$$

- 8.7** A 1-F parallel-plate capacitor has a ceramic dielectric 1 mm thick. If the plates are square, find the length of a side of a plate.

Because each plate is square, a length l of a side is $l = \sqrt{A}$. From this and $C = \epsilon A/d$,

$$l = \sqrt{\frac{dC}{\epsilon}} = \sqrt{\frac{10^{-3} \times 1}{7500(8.85 \times 10^{-12})}} = 123 \text{ m}$$

Each side is 123 m long or, approximately, 1.3 times the length of a football field. This problem demonstrates that the farad is an extremely large unit.

- 8.8** What are the different capacitances that can be obtained with a 1- and a $3\text{-}\mu\text{F}$ capacitor?

The capacitors can produce 1 and $3\text{ }\mu\text{F}$ individually; $1 + 3 = 4\text{ }\mu\text{F}$ in parallel; and $(1 \times 3)/(1 + 3) = 0.75\text{ }\mu\text{F}$ in series

- 8.9** Find the total capacitance C_T of the circuit shown in Fig. 8-7.

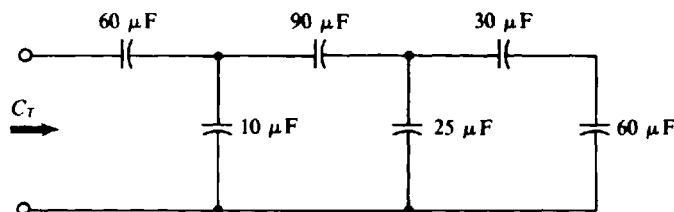

Fig. 8-7

At the end opposite the input, the series 30- and $60\text{-}\mu\text{F}$ capacitors have a total capacitance of $30 \times 60/(30 + 60) = 20\text{ }\mu\text{F}$. This adds to the capacitance of the parallel $25\text{-}\mu\text{F}$ capacitor for a total of $45\text{ }\mu\text{F}$ to the right of the $90\text{-}\mu\text{F}$ capacitor. The 45- and $90\text{-}\mu\text{F}$ capacitances combine to $45 \times 90/(45 + 90) = 30\text{ }\mu\text{F}$. This adds to the capacitance of the parallel $10\text{-}\mu\text{F}$ capacitor for a total of $30 + 10 = 40\text{ }\mu\text{F}$ to the right of the $60\text{-}\mu\text{F}$ capacitor. Finally,

$$C_T = \frac{60 \times 40}{60 + 40} = 24\text{ }\mu\text{F}$$

8.10 A $4\text{-}\mu\text{F}$ capacitor, a $6\text{-}\mu\text{F}$ capacitor, and an $8\text{-}\mu\text{F}$ capacitor are in parallel across a 300-V source. Find (a) the total capacitance, (b) the magnitude of charge stored by each capacitor, and (c) the total stored energy.

(a) Because the capacitors are in parallel, the total or equivalent capacitance is the sum of the individual capacitances: $C_T = 4 + 6 + 8 = 18\ \mu\text{F}$.

(b) The three charges are, from $Q = CV$, $(4 \times 10^{-6})(300)\ \text{C} = 1.2\ \text{mC}$, $(6 \times 10^{-6})(300)\ \text{C} = 1.8\ \text{mC}$, and $(8 \times 10^{-6})(300)\ \text{C} = 2.4\ \text{mC}$ for the 4- , 6- , and $8\text{-}\mu\text{F}$ capacitors, respectively.

(c) The total capacitance can be used to obtain the total stored energy:

$$W = \frac{1}{2}C_T V^2 = 0.5(18 \times 10^{-6})(300)^2 = 0.81\ \text{J}$$

8.11 Repeat Prob. 8.10 for the capacitors in series instead of in parallel, but find each capacitor voltage instead of each charge stored.

(a) Because the capacitors are in series, the total capacitance is the reciprocal of the sum of the reciprocals of the individual capacitances:

$$C_T = \frac{1}{1/4 + 1/6 + 1/8} = 1.846\ \mu\text{F}$$

(b) The voltage across each capacitor depends on the charge stored, which is the same for each capacitor. This charge can be obtained from the total capacitance and the applied voltage:

$$Q = C_T V = (1.846 \times 10^{-6})(300)\ \text{C} = 554\ \mu\text{C}$$

From $V = Q/C$, the individual capacitor voltages are

$$\frac{554 \times 10^{-6}}{4 \times 10^{-6}} = 138.5\ \text{V} \quad \frac{554 \times 10^{-6}}{6 \times 10^{-6}} = 92.3\ \text{V} \quad \frac{554 \times 10^{-6}}{8 \times 10^{-6}} = 69.2\ \text{V}$$

for the 4- , 6- , and $8\text{-}\mu\text{F}$ capacitors, respectively.

(c) The total stored energy is

$$W = \frac{1}{2}C_T V^2 = 0.5(1.846 \times 10^{-6})(300)^2\ \text{J} = 83.1\ \text{mJ}$$

8.12 A 24-V source and two capacitors are connected in series. If one capacitor has $20\ \mu\text{F}$ of capacitance and has $16\ \text{V}$ across it, what is the capacitance of the other capacitor?

By KVL, the other capacitor has $24 - 16 = 8\ \text{V}$ across it. Also, the charge on it is the same as that on the other capacitor: $Q = CV = (20 \times 10^{-6})(16)\ \text{C} = 320\ \mu\text{C}$. So, $C = Q/V = 320 \times 10^{-6} / 8\ \text{F} = 40\ \mu\text{F}$.

8.13 Find each capacitor voltage in the circuit shown in Fig. 8-8.

The approach is to find the equivalent capacitance, use it to find the charge, and then use this charge to find the voltages across the 6- and $12\text{-}\mu\text{F}$ capacitors, which have this same charge because they are in series with the source.

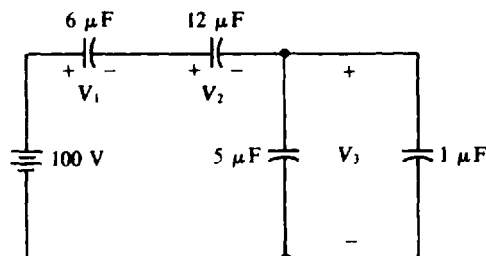

Fig. 8-8

At the end opposite the source, the two parallel capacitors have an equivalent capacitance of $5 + 1 = 6 \mu\text{F}$. With this reduction, the capacitors are in series, making

$$C_T = \frac{1}{\frac{1}{1.6} + \frac{1}{1.12} + \frac{1}{1.6}} = 2.4 \mu\text{F}$$

The desired charge is

$$Q = CV = (2.4 \times 10^{-6})(100) \text{ C} = 240 \mu\text{C}$$

which is the charge on the $6\text{-}\mu\text{F}$ capacitor as well as on the $12\text{-}\mu\text{F}$ capacitor. From $V = Q/C$,

$$V_1 = \frac{240 \times 10^{-6}}{6 \times 10^{-6}} = 40 \text{ V} \quad V_2 = \frac{240 \times 10^{-6}}{12 \times 10^{-6}} = 20 \text{ V}$$

and, by KVL, $V_3 = 100 - V_1 - V_2 = 40 \text{ V}$.

8.14 Find each capacitor voltage in the circuit shown in Fig. 8-9.

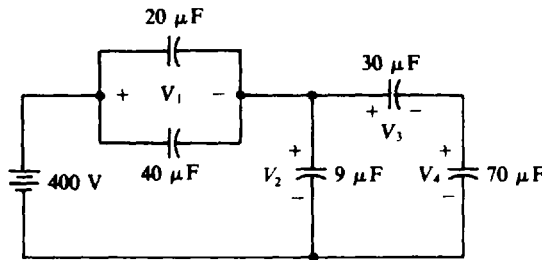

Fig. 8-9

A good analysis method is to reduce the circuit to a series circuit with two capacitors and the voltage source, find the charge on each reduced capacitor, and from it find the voltages across these capacitors. Then the process can be partially repeated to find all the capacitor voltages in the original circuit.

The parallel 20- and $40\text{-}\mu\text{F}$ capacitors reduce to a single $60\text{-}\mu\text{F}$ capacitor. The 30- and $70\text{-}\mu\text{F}$ capacitors reduce to a $30 \times 70 / (30 + 70) = 21\text{-}\mu\text{F}$ capacitor in parallel with the $9\text{-}\mu\text{F}$ capacitor. So, all three of these capacitors reduce to a $21 + 9 = 30\text{-}\mu\text{F}$ capacitor that is in series with the reduced $60\text{-}\mu\text{F}$ capacitor, and the total capacitance at the source terminals is $30 \times 60 / (30 + 60) = 20 \mu\text{F}$. The desired charge is

$$Q = C_T V = (20 \times 10^{-6})(400) \text{ C} = 8 \text{ mC}$$

This charge can be used to obtain V_1 and V_2 :

$$V_1 = \frac{8 \times 10^{-3}}{60 \times 10^{-6}} = 133 \text{ V} \quad \text{and} \quad V_2 = \frac{8 \times 10^{-3}}{30 \times 10^{-6}} = 267 \text{ V}$$

Alternatively, $V_2 = 400 - V_1 = 400 - 133 = 267 \text{ V}$.

The charge on the $30\text{-}\mu\text{F}$ capacitor and also on the series $70\text{-}\mu\text{F}$ capacitor is the 8 mC minus the charge on the $9\text{-}\mu\text{F}$ capacitor:

$$8 \times 10^{-3} - (9 \times 10^{-6})(267) \text{ C} = 5.6 \text{ mC}$$

Consequently, from $V = Q/C$,

$$V_3 = \frac{5.6 \times 10^{-3}}{30 \times 10^{-6}} = 187 \text{ V} \quad \text{and} \quad V_4 = \frac{5.6 \times 10^{-3}}{70 \times 10^{-6}} = 80 \text{ V}$$

As a check $V_3 + V_4 = 187 + 80 = 267 \text{ V} = V_2$.

- 8.15** A $3\text{-}\mu\text{F}$ capacitor charged to 100 V is connected across an uncharged $6\text{-}\mu\text{F}$ capacitor. Find the voltage and also the initial and final stored energies.

The charge and capacitance are needed to find the voltage from $V = Q/C$. Initially, the charge on the $3\text{-}\mu\text{F}$ capacitor is $Q = CV = (3 \times 10^{-6})(100)\text{ C} = 0.3\text{ mC}$. When the capacitors are connected together, this charge distributes over the two capacitors, but does not change. Since the same voltage is across both capacitors, they are in parallel. So, $C_T = 3 + 6 = 9\text{ }\mu\text{F}$, and

$$V = \frac{Q}{C_T} = \frac{0.3 \times 10^{-3}}{9 \times 10^{-6}} = 33.3\text{ V}$$

The initial energy is all stored by the $3\text{-}\mu\text{F}$ capacitor: $\frac{1}{2}CV^2 = 0.5(3 \times 10^{-6})(100)^2\text{ J} = 15\text{ mJ}$. The final energy is stored by both capacitors: $0.5(9 \times 10^{-6})(33.3)^2\text{ J} = 5\text{ mJ}$.

- 8.16** Repeat Prob. 8.15 for an added $2\text{-k}\Omega$ series resistor in the circuit.

The resistor has no effect on the final voltage, which is 33.3 V , because this voltage depends only on the equivalent capacitance and the charge stored, neither of which are affected by the presence of the resistor. Since the final voltage is the same, the final energy storage is the same: 5 mJ . Of course, the resistor has no effect on the initial 15 mJ stored. The resistor will, however, slow the time taken for the voltage to reach its final value, which time is five time constants after the switching. This time is zero if the resistance is zero. The presence of the resistor also makes it easier to account for the 10-mJ decrease in stored energy—it is dissipated in the resistor.

- 8.17** A $2\text{-}\mu\text{F}$ capacitor charged to 150 V and a $1\text{-}\mu\text{F}$ capacitor charged to 50 V are connected together with plates of opposite polarity joined. Find the voltage and the initial and final stored energies.

Because of the opposite polarity connection, some of the charge on one capacitor cancels that on the other. The initial charges are $(2 \times 10^{-6})(150)\text{ C} = 300\text{ }\mu\text{C}$ for the $2\text{-}\mu\text{F}$ capacitor and $(1 \times 10^{-6})(50)\text{ C} = 50\text{ }\mu\text{C}$ for the $1\text{-}\mu\text{F}$ capacitor. The final charge distributed over both capacitors is the difference of these two charges: $300 - 50 = 250\text{ }\mu\text{C}$. It produces a voltage of

$$V = \frac{Q}{C_T} = \frac{250 \times 10^{-6}}{2 \times 10^{-6} + 1 \times 10^{-6}} = 83.3\text{ V}$$

The initial stored energy is the sum of the energies stored by both capacitors:

$$0.5(2 \times 10^{-6})(150)^2 + 0.5(1 \times 10^{-6})(50)^2 = 23.8\text{ mJ}$$

The final stored energy is

$$\frac{1}{2}C_T V_T^2 = 0.5(3 \times 10^{-6})(83.3)^2\text{ J} = 10.4\text{ mJ}$$

- 8.18** What is the current flowing through a $2\text{-}\mu\text{F}$ capacitor when the capacitor voltage is 10 V ?

There is not enough information to find the capacitor current. This current depends on the rate of change of capacitor voltage and *not* the voltage value, and this rate is not given.

- 8.19** If the voltage across a $0.1\text{-}\mu\text{F}$ capacitor is $3000t\text{ V}$, find the capacitor current.

The capacitor current equals the product of the capacitance and the time derivative of the voltage. Since the time derivative of $3000t$ is 3000 ,

$$i = C \frac{dv}{dt} = (0.1 \times 10^{-6})(3000)\text{ A} = 0.3\text{ mA}$$

which is a constant value.

The capacitor current can also be found from $i = C \Delta v / \Delta t$ because the voltage is increasing linearly. If Δt is taken as, say, 2 s, from 0 to 2 s, the corresponding Δv is $3000\Delta t = 3000(2 - 0) = 6000$ V. So,

$$i = C \frac{\Delta v}{\Delta t} = \frac{(0.1 \times 10^{-6})(6000)}{2} \text{ A} = 0.3 \text{ mA}$$

8.20 Sketch the waveform of the current that flows through a $2\text{-}\mu\text{F}$ capacitor when the capacitor voltage is as shown in Fig. 8-10. As always, assume associated references because there is no statement to the contrary.

Graphically, the dv/dt in $i = C dv/dt$ is the *slope* of the voltage graph. For straight lines this slope is the same as $\Delta v / \Delta t$. For this voltage graph, the straight line for the interval of $t = 0$ s to $t = 1 \mu\text{s}$ has a slope of $(20 - 0)/(1 \times 10^{-6} - 0) \text{ V/s} = 20 \text{ MV/s}$, which is the voltage at $t = 1 \mu\text{s}$ minus the voltage at $t = 0$ s, divided by the time at $t = 1 \mu\text{s}$ minus the time at $t = 0$ s. As a result, during this time interval the current is $i = C dv/dt = (2 \times 10^{-6})(20 \times 10^6) = 40$ A.

From $t = 1 \mu\text{s}$ to $t = 4 \mu\text{s}$, the voltage graph is horizontal, which means that the slope and, consequently, the current are zero: $i = 0$ A.

For the time interval from $t = 4 \mu\text{s}$ to $t = 6 \mu\text{s}$, the straight line has a slope of $(-20 - 20)/(6 \times 10^{-6} - 4 \times 10^{-6}) \text{ V/s} = -20 \text{ MV/s}$. This change in voltage produces a current of $i = C dv/dt = (2 \times 10^{-6})(-20 \times 10^6) = -40$ A.

Finally, from $t = 6 \mu\text{s}$ to $t = 8 \mu\text{s}$, the slope of the straight line is $[0 - (-20)]/(8 \times 10^{-6} - 6 \times 10^{-6}) \text{ V/s} = 10 \text{ MV/s}$ and the capacitor current is $i = C dv/dt = (2 \times 10^{-6})(10 \times 10^6) = 20$ A.

Figure 8-11 is a graph of the capacitor current. Notice that, unlike capacitor voltage, capacitor current can jump, as it does at 1, 4, and 6 μs . In fact, at 6 μs the current reverses direction instantaneously.

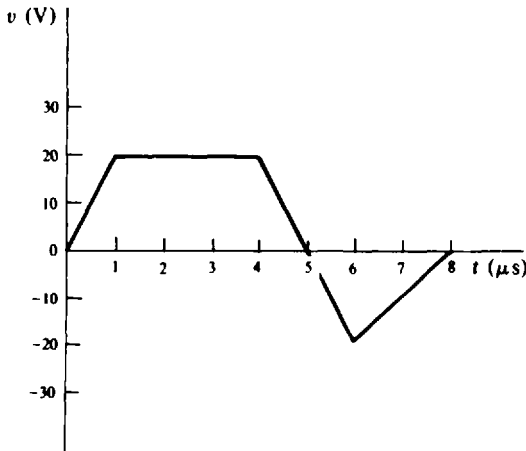

Fig. 8-10

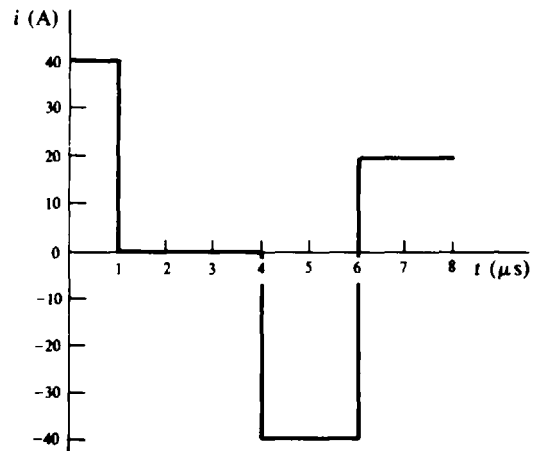

Fig. 8-11

8.21 Find the time constant of the circuit shown in Fig. 8-12.

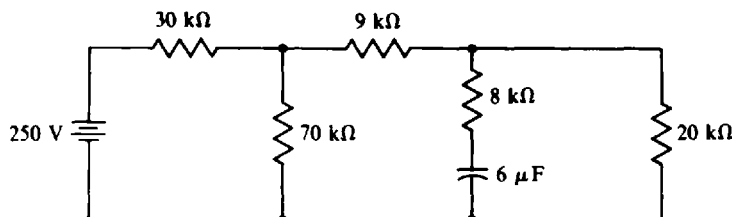

Fig. 8-12

The time constant is $\tau = R_{Th}C$, where R_{Th} is the Thévenin resistance at the capacitor terminals. Here,

$$R_{Th} = 8 + 20 \parallel (9 + 70 \parallel 30) = 8 + 20 \parallel 30 = 20 \text{ k}\Omega$$

and so the time constant is $\tau = R_{Th}C = (20 \times 10^3)(6 \times 10^{-6}) = 0.12 \text{ s}$.

- 8.22** How long does a $20\text{-}\mu\text{F}$ capacitor charged to 150 V take to discharge through a $3\text{-M}\Omega$ resistor? Also, at what time does the maximum discharge current occur and what is its value?

The discharge is considered to be completed after five time constants:

$$5\tau = 5RC = 5(3 \times 10^6)(20 \times 10^{-6}) = 300 \text{ s}$$

Since the current decreases as the capacitor discharges, it has a graph as shown in Fig. 8-5a with a maximum value at the time of switching, $t = 0 \text{ s}$ here. In this circuit the current has an initial value of $150/(3 \times 10^6) \text{ A} = 50 \mu\text{A}$ because initially the capacitor voltage of 150 V , which cannot jump, is across the $3\text{-M}\Omega$ resistor.

- 8.23** At $t = 0 \text{ s}$, a 100-V source is switched in series with a $1\text{-k}\Omega$ resistor and an uncharged $2\text{-}\mu\text{F}$ capacitor. What are (a) the initial capacitor voltage, (b) the initial current, (c) the initial rate of capacitor voltage increase, and (d) the time required for the capacitor voltage to reach its maximum value?

(a) Since the capacitor voltage is zero before the switching, it is also zero immediately after the switching a capacitor voltage cannot jump: $v(0+) = 0 \text{ V}$.

(b) By KVL, at $t = 0+ \text{ s}$ the 100 V of the source is all across the $1\text{-k}\Omega$ resistor because the capacitor voltage is 0 V . Consequently, $i(0+) = 100/10^3 \text{ A} = 100 \text{ mA}$.

(c) As can be seen from Fig. 8-5b, the initial rate of capacitor voltage increase equals the total change in capacitor voltage divided by the circuit time constant. In this circuit the capacitor voltage eventually equals the 100 V of the source. Of course, the initial value is 0 V . Also, the time constant is $\tau = RC = 10^3(2 \times 10^{-6}) \text{ s} = 2 \text{ ms}$. So, the initial rate of capacitor voltage increase is $100/(2 \times 10^{-3}) = 50\,000 \text{ V/s}$. This initial rate can also be found from $i = C dv/dt$ evaluated at $t = 0+ \text{ s}$:

$$\frac{dv}{dt}(0+) = \frac{i(0+)}{C} = \frac{100 \times 10^{-3}}{2 \times 10^{-6}} = 50\,000 \text{ V/s}$$

(d) It takes five time constants, $5 \times 2 = 10 \text{ ms}$, for the capacitor voltage to reach its final value of 100 V .

- 8.24** Repeat Prob. 8.23 for an initial capacitor charge of $50 \mu\text{C}$. The positive plate of the capacitor is toward the positive terminal of the 100-V source.

(a) The initial capacitor voltage is $V = Q/C = (50 \times 10^{-6})/(2 \times 10^{-6}) = 25 \text{ V}$.

(b) At $t = 0+ \text{ s}$, the voltage across the resistor is, by KVL, the source voltage minus the initial capacitor voltage. This voltage difference divided by the resistance is the initial current: $i(0+) = (100 - 25)/10^3 \text{ A} = 75 \text{ mA}$.

(c) The initial rate of capacitor voltage increase equals the total change in capacitor voltage divided by the time constant: $75/(2 \times 10^{-3}) = 37\,500 \text{ V/s}$.

(d) The initial capacitor voltage has no effect on the circuit time constant and so also not on the time required for the capacitor voltage to reach its final value. This time is 10 ms , the same as for the circuit discussed in Prob. 8.23.

- 8.25** In the circuit shown in Fig. 8-13, find the indicated voltages and currents at $t = 0+ \text{ s}$, immediately after the switch closes. The capacitors are initially uncharged. Also, find these voltages and currents "a long time" after the switch closes.

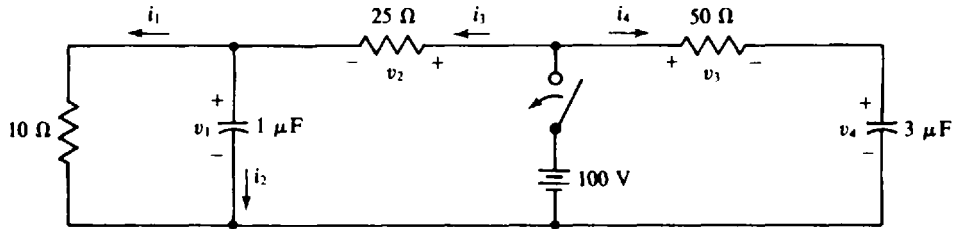

Fig. 8-13

At $t = 0 + s$, the capacitors have 0 V across them because the capacitor voltages cannot jump from the 0-V values that they have at $t = 0 - s$, immediately before the switching: $v_1(0+) = 0$ V and $v_4(0+) = 0$ V. Further, with 0 V across them, the capacitors act like short circuits at $t = 0 + s$, with the result that the 100 V of the source is across both the 25- Ω and 50- Ω resistors: $v_2(0+) = v_3(0+) = 100$ V. Three of the initial currents can be found from these voltages:

$$i_1(0+) = \frac{0}{10} = 0 \text{ A} \quad i_3(0+) = \frac{100}{25} = 4 \text{ A} \quad i_4(0+) = \frac{100}{50} = 2 \text{ A}$$

The remaining initial current, $i_2(0+)$, can be found by applying KCL at the node at the top of the 1- μ F capacitor:

$$i_2(0+) = i_3(0+) - i_1(0+) = 4 - 0 = 4 \text{ A}$$

A "long time" after the switch closes means more than five time constants later. At this time the capacitor voltages are constant, and so the capacitors act like open circuits, blocking i_2 and i_4 : $i_2(\infty) = i_4(\infty) = 0$ A. With the 1- μ F capacitor acting like an open circuit, the 10- Ω and 25- Ω resistors are in series across the 100-V source, and so $i_1(\infty) = i_3(\infty) = 100/35 = 2.86$ A. From the resistances and the calculated currents, $v_1(\infty) = 10 \times 2.86 = 28.6$ V, $v_2(\infty) = 25 \times 2.86 = 71.4$ V, and $v_3(\infty) = 0 \times 50 = 0$ V. Finally, from the right-hand mesh,

$$v_4(\infty) = 100 - v_3(\infty) = 100 - 0 = 100 \text{ V}$$

8.26 A 2- μ F capacitor, initially charged to 300 V, is discharged through a 270-k Ω resistor. What is the capacitor voltage at 0.25 s after the capacitor starts to discharge?

The voltage formula is $v = v(\infty) + [v(0+) - v(\infty)]e^{-t/\tau}$. Since the time constant is $\tau = RC = (270 \times 10^3)(2 \times 10^{-6}) = 0.54$ s, the initial capacitor voltage is $v(0+) = 300$ V, and the final capacitor voltage is $v(\infty) = 0$ V, it follows that the equation for the capacitor voltage is

$$v(t) = 0 + (300 - 0)e^{-t/0.54} = 300e^{-1.85t} \text{ V} \quad \text{for } t \geq 0 \text{ s}$$

From this, $v(0.25) = 300e^{-1.85(0.25)} = 189$ V.

8.27 Closing a switch connects in series a 200-V source, a 2-M Ω resistor, and an uncharged 0.1- μ F capacitor. Find the capacitor voltage and current at 0.1 s after the switch closes.

The voltage formula is $v = v(\infty) + [v(0+) - v(\infty)]e^{-t/\tau}$. Here, $v(\infty) = 200$ V, $v(0+) = 0$ V, and $\tau = (2 \times 10^6)(0.1 \times 10^{-6}) = 0.2$ s. So,

$$v(t) = 200 + [0 - 200]e^{-t/0.2} = 200 - 200e^{-5t} \text{ V} \quad \text{for } t > 0 \text{ s}$$

Substitution of 0.1 to t gives $v(0.1)$:

$$v(0.1) = 200 - 200e^{-0.5} = 78.7 \text{ V}$$

Similarly, $i = i(\infty) + [i(0+) - i(\infty)]e^{-t/\tau}$, in which $i(0+) = 200/(2 \times 10^6)$ A = 0.1 mA, $i(\infty) = 0$ A, and of course $\tau = 0.2$ s. With these values inserted,

$$i(t) = 0 + (0.1 - 0)e^{-5t} = 0.1e^{-5t} \text{ mA} \quad \text{for } t > 0 \text{ s}$$

From this, $i(0.1) = 0.1e^{-0.5} \text{ mA} = 60.7 \mu\text{A}$. This current can also be found by using the voltage across the resistor at $t = 0.1 \text{ s}$: $i(0.1) = (200 - 78.7)(2 \times 10^6) \text{ A} = 60.7 \mu\text{A}$.

- 8.28** For the circuit used in Prob. 8.27, find the time required for the capacitor voltage to reach 50 V. Then find the time required for the capacitor voltage to increase another 50 V, from 50 to 100 V. Compare times.

From the solution to Prob. 8.27, $v(t) = 200 - 200e^{-5t} \text{ V}$. To find the time at which the voltage is 50 V, it is only necessary to substitute 50 for $v(t)$ and solve for t : $50 = 200 - 200e^{-5t}$ or $e^{-5t} = 150/200 = 0.75$. The exponential can be eliminated by taking the natural logarithm of both sides:

$$\ln e^{-5t} = \ln 0.75 \quad \text{from which} \quad -5t = -0.288 \quad \text{and} \quad t = 0.288/5 \text{ s} = 57.5 \text{ ms}$$

The same procedure can be used to find the time at which the capacitor voltage is 100 V: $100 = 200 - 200e^{-5t}$ or $e^{-5t} = 100/200 = 0.5$. Further,

$$\ln e^{-5t} = \ln 0.5 \quad \text{from which} \quad -5t = -0.693 \quad \text{and} \quad t = 0.693/5 \text{ s} = 138.6 \text{ ms}$$

The voltage required 57.5 ms to reach 50 V, and $138.6 - 57.5 = 81.1 \text{ ms}$ to increase another 50 V, which verifies the fact that the rate of increase becomes less and less as time increases.

- 8.29** In the circuit shown in Fig. 8-14, the switch closes at $t = 0 \text{ s}$. Find v_c and i for $t > 0 \text{ s}$ if $v_c(0) = 100 \text{ V}$.

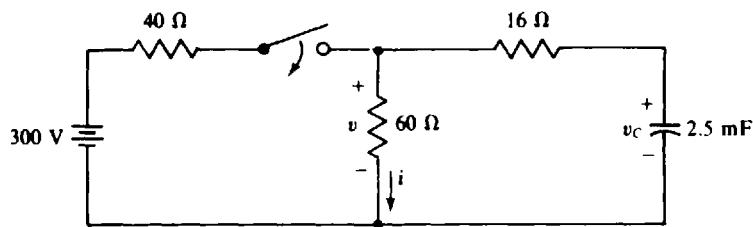

Fig. 8-14

All that are needed for the v and i formulas are $v_c(0+)$, $v_c(\infty)$, $i(0+)$, $i(\infty)$, and $\tau = R_{\text{th}}C$. Of course, $v_c(0+) = 100 \text{ V}$ because the capacitor voltage cannot jump. The voltage $v_c(\infty)$ is the same as the voltage across the 60-Ω resistor a long time after the switch closes, because at this time the capacitor acts like an open circuit. So, by voltage division,

$$v_c(\infty) = \frac{60}{60 + 40} \times 300 = 180 \text{ V}$$

Also, $i(\infty) = v_c(\infty)/60 = 180/60 = 3 \text{ A}$. It is easy to obtain $i(0+)$ from $v(0+)$, which can be solved for using a nodal equation at the middle top node for the time $t = 0+$:

$$\frac{v(0+) - 300}{40} + \frac{v(0+) - v_c(0+)}{60} + \frac{v(0+) - 100}{16} = 0$$

from which $v(0+) = 132 \text{ V}$. So, $i(0+) = 132/60 = 2.2 \text{ A}$. Since the Thévenin resistance at the capacitor terminals is $16 + 60 \parallel 40 = 40 \Omega$, the time constant is $\tau = RC = 40(2.5 \times 10^{-3}) = 0.1 \text{ s}$.

With these quantities substituted into the v and i formulas,

$$v_c(t) = v_c(\infty) + [v_c(0+) - v_c(\infty)]e^{-t/\tau} = 180 + (100 - 180)e^{-10t} = 180 - 80e^{-10t} \text{ V} \quad \text{for } t > 0 \text{ s}$$

$$i(t) = i(\infty) + [i(0+) - i(\infty)]e^{-t/\tau} = 3 + (2.2 - 3)e^{-10t} = 3 - 0.8e^{-10t} \text{ A} \quad \text{for } t > 0 \text{ s}$$

- 8.30** The switch is closed at $t = 0 \text{ s}$ in the circuit shown in Fig. 8-15. Find i for $t > 0 \text{ s}$. The capacitor is initially uncharged.

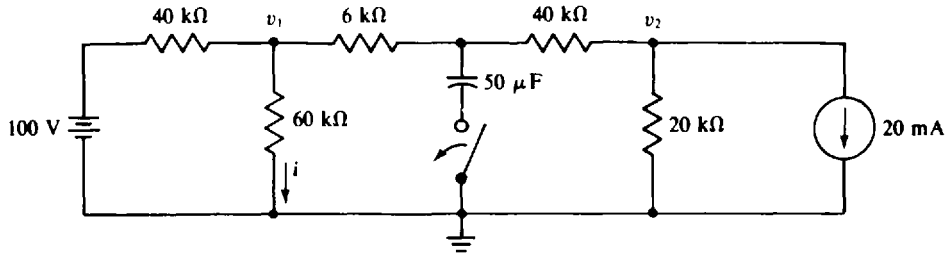

Fig. 8-15

The quantities $i(0+)$, $i(\infty)$, and τ are needed for the current formula

$$i = i(\infty) + [i(0+) - i(\infty)]e^{-t/\tau}$$

At $t = 0+$ s, the short-circuiting action of the capacitor prevents the 20-mA current source from affecting $i(0+)$. Also, it places the 6-k Ω resistor in parallel with the 60-k Ω resistor. Consequently, by current division,

$$i(0+) = \left(\frac{6}{60 + 6}\right)\left(\frac{100}{40 + 6}\right) = 0.2 \text{ mA}$$

in which the simplifying kilohm-milliampere method is used.

After five time constants the capacitor no longer conducts current and can be considered to be an open circuit and so neglected in the calculations. By nodal analysis,

$$\left(\frac{1}{40} + \frac{1}{60} + \frac{1}{46}\right)v_1(\infty) - \frac{1}{46}v_2(\infty) = \frac{100}{40} \quad -\frac{1}{46}v_1(\infty) + \left(\frac{1}{46} + \frac{1}{20}\right)v_2(\infty) = -20$$

from which $v_1(\infty) = -62.67$ V. So, $i(\infty) = -62.67 (60 \times 10^3) \text{ A} = -1.04$ mA.

The Thévenin resistance at the capacitor terminals is $(6 + 40 \parallel 60) (40 + 20) = 20$ k Ω . This can be used to find the time constant:

$$\tau = R_{Th}C = (20 \times 10^3)(50 \times 10^{-6}) = 1 \text{ s}$$

Now that $i(0+)$, $i(\infty)$, and τ are known, the current i can be found:

$$i = -1.04 + [0.2 - (-1.04)]e^{-t} = -1.04 + 1.24e^{-t} \text{ mA} \quad \text{for } t > 0 \text{ s}$$

8.31 After a long time in position 1, the switch in the circuit shown in Fig. 8-16 is thrown to position 2 at $t = 0$ s for a duration of 30 s and then returned to position 1. (a) Find the equations for v for $t \geq 0$ s. (b) Find v at $t = 5$ s and at $t = 40$ s. (c) Make a sketch of v for $0 \text{ s} \leq t \leq 80$ s.

(a) At the time that the switch is thrown to position 2, the initial capacitor voltage is 20 V, the same as immediately before the switching; the final capacitor voltage is 70 V, the voltage of the source in the circuit; and the time constant is $(20 \times 10^6)(2 \times 10^{-6}) = 40$ s. Consequently, while the switch is in position 2,

$$v = 70 + (20 - 70)e^{-t/40} = 70 - 50e^{-0.025t} \text{ V}$$

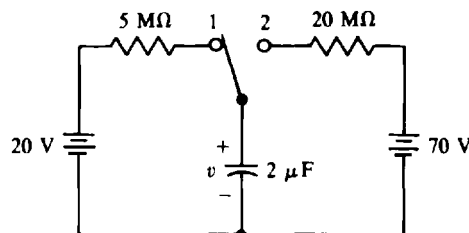

Fig. 8-16

Of course, the capacitor voltage never reaches the "final voltage" because a switching operation interrupts the charging, but the circuit does not "know" this ahead of time.

When the switch is returned to position 1, the circuit changes, and so the equation for v changes. The initial voltage at this $t = 30$ -s switching can be found by substituting 30 for t in the equation for v that was just calculated: $v(30) = 70 - 50e^{-0.025(30)} = 46.4$ V. The final capacitor voltage is 20 V, and the time constant is $(5 \times 10^{-6})(2 \times 10^{-6}) = 10$ s. For these values, the basic voltage formula must be modified since the switching occurs at $t = 30$ s instead of at $t = 0+$ s. The modified formula is

$$v(t) = v(\infty) + [v(30+) - v(\infty)]e^{-t/30} \text{ V} \quad \text{for} \quad t \geq 30 \text{ s}$$

The $t - 30$ is necessary in the exponent to account for the time shift. With the values inserted into this formula, the capacitor voltage is

$$v(t) = 20 + (46.4 - 20)e^{-0.1(t - 30)} = 20 + 26.4e^{-0.1(t - 30)} \text{ V} \quad \text{for} \quad t \geq 30 \text{ s}$$

- (b) For v at $t = 5$ s, the first voltage equation must be used because it is the one that is valid for the first 30 s: $v(5) = 70 - 50e^{-0.025(5)} = 25.9$ V. For v at $t = 40$ s, the second equation must be used because it is the one that is valid after 30 s: $v(40) = 20 + 26.4e^{-0.1(40 - 30)} = 29.7$ V.
- (c) Figure 8-17 shows the voltage graph which is based on the two voltage equations. The voltage rises exponentially to 46.4 V at $t = 30$ s, heading toward 70 V. After 30 s, the voltage decays exponentially to the final value of 20 V, reaching it at 80 s, five time constants after the switch returns to position 1.

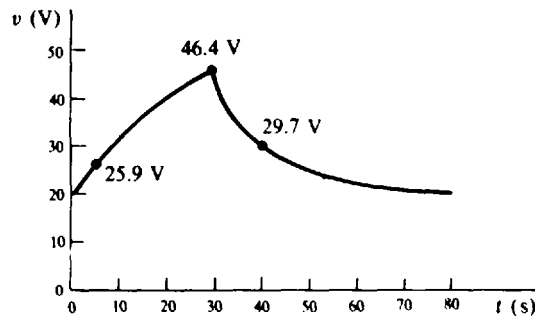

Fig. 8-17

- 8.32** A simple RC timer has a switch that when closed connects in series a 300-V source, a 16-M Ω resistor, and an uncharged 10- μ F capacitor. Find the time between the closing and opening of the switch if the capacitor charges to 10 V during this time.

Because 10 V is less than one-tenth of the final voltage of 300 V, a linear approximation can be used. In this approximation the rate of voltage change is considered to be constant at its initial value. Although not needed, this rate is the quotient of the possible total voltage change of 300 V and the time constant of $RC = (16 \times 10^6)(10 \times 10^{-6}) = 160$ s. Since the voltage that the capacitor charges to is 1/30th of the possible total voltage change, the time required for this charging is approximately 1/30th of the time constant: $t \approx 160/30 = 5.33$ s.

This time can be found more accurately, but with more effort, from the voltage formula. For it, $v(0+) = 0$ V, $v(\infty) = 300$ V, and $\tau = 160$ s. With these values inserted, the capacitor voltage equation is $v = 300 - 300e^{-t/160}$. For $v = 10$ V, it becomes $10 = 300 - 300e^{-t/160}$, from which $t = 160 \ln(300/290) = 5.42$ s. The approximation of 5.33 s is within 2 percent of this formula value of 5.42 s.

- 8.33** Repeat Prob. 8.32 for a capacitor voltage of 250 V.

The approximation cannot be used since 250 V is more than one-tenth of 300 V. The exact formula must be used. From the solution to Prob. 8.32, $v = 300 - 300e^{-t/160}$. For $v = 250$ V, it becomes $250 = 300 - 300e^{-t/160}$, which simplifies to $t = 160 \ln(300/50) = 287$ s. By comparison, the linear approximation gives $t = (250/300)(160) = 133$ s, which is considerably in error.

- 8.34** For the oscillator circuit shown in Fig. 8-18, find the period of oscillation if the gas tube fires at 90 V and extinguishes at 10 V. The gas tube has a 50-Ω resistance when firing and a 10¹⁰-Ω resistance when extinguished.

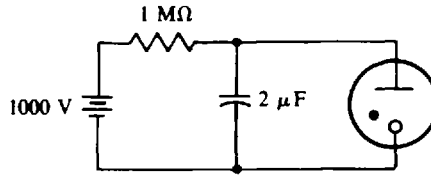

Fig. 8-18

When extinguished, the gas tube has such a large resistance (10¹⁰ Ω) compared to the 1-MΩ resistance of the resistor that it can be considered to be an open circuit and neglected during the charging time of the capacitor. During this time, the capacitor charges from an initial 10 V toward the 1000 V of the source, but stops charging when its voltage reaches 90 V, at which time the tube fires. Although this voltage change is 90 - 10 = 80 V, the initial circuit action is as if the total voltage change will be 1000 - 10 = 990 V. Since 80 V is less than one-tenth of 990 V, a linear approximation can be used to find the proportion that the charging time is of the time constant of 10⁶(2 × 10⁻⁶) = 2 s. The proportionality is $t/2 = 80/990$, from which $t = 160/990 = 0.162$ s. If an exact analysis is made, the result is 0.168 52 s.

When the tube fires, its 50-Ω resistance is so small compared to the 1-MΩ resistance of the resistor that the resistor can be considered to be an open circuit and neglected along with the voltage source. So, the discharging circuit is essentially an initially charged 2-μF capacitor and a 50-Ω resistor, until the voltage drops from the 90-V initial voltage to the 10-V extinguishing voltage. The time constant of this circuit is just (2 × 10⁻⁶)(50) s = 0.1 ms. This is so short compared to the charging time that the discharging time can usually be neglected even if five time constants are used for the discharge time. If an exact analysis is made, the result is a time of 0.22 ms for the capacitor to discharge from 90 to 10 V.

In summary, by approximations the period is $T = 0.162 + 0 = 0.162$ s, as compared to the exact-method result of $T = 0.168 52 + 0.000 22 = 0.168 74$ s or 0.169 s to three significant digits. Note that the approximate result is within about 4 percent of the actual result. This is usually good enough, especially in view of the fact that in the actual circuit the component values probably differ from the specified values by more than this.

- 8.35** Repeat Prob. 8.34 with the source voltage changed from 1000 V to 100 V.

During the charge cycle the capacitor charges toward 100 V from an initial 10 V, the same as if the total voltage change will be 100 - 10 = 90 V. Since the actual voltage change of 90 - 10 = 80 V is considerably more than one-tenth of 90 V, a linear approximation is not valid. The exact method must be used. For this, $v(\infty) = 100$ V, $v(0+) = 10$ V, and $\tau = 2$ s. The corresponding voltage formula is

$$v = 100 + (10 - 100)e^{-t/2} = 100 - 90e^{-t/2} \text{ V}$$

The desired time is found by letting $v = 90$ V, and solving for t : $90 = 100 - 90e^{-t/2}$, which simplifies to $t = 2 \ln(90/10) = 4.39$ s. This is the period because the discharge time, which is the same as that found in the solution to Prob. 8.34, is negligible compared to this time.

Supplementary Problems

- 8.36** What electron movement between the plates of a 0.1-μF capacitor produces a 110-V change of voltage?

Ans. 6.87×10^{13} electrons

- 8.37** If the movement of 4.68×10^{14} electrons between the plates of a capacitor produces a 150-V change in capacitor voltage, find the capacitance.
Ans. $0.5 \mu\text{F}$
- 8.38** What change in voltage of a $20\text{-}\mu\text{F}$ capacitor is produced by a movement of 9×10^{14} electrons between plates?
Ans. 7.21 V
- 8.39** A tubular capacitor consists of two sheets of aluminum foil 3 cm wide and 1 m long, rolled into a tube with separating sheets of waxed paper of the same size. What is the capacitance if the paper is 0.1 mm thick and has a dielectric constant of 3.5?
Ans. 9.29 nF
- 8.40** Find the area for each plate of a $10\text{-}\mu\text{F}$ parallel-plate capacitor that has a ceramic dielectric 0.5 mm thick.
Ans. 0.0753 m^2
- 8.41** Find the thickness of the mica dielectric of a 10-pF parallel-plate capacitor if the area of each plate is 10^{-4} m^2 .
Ans. 0.443 mm
- 8.42** Find the diameter of a disk-shaped $0.001\text{-}\mu\text{F}$ capacitor that has a ceramic dielectric 1 mm thick.
Ans. 4.38 mm
- 8.43** What are the different capacitances that can be obtained with a $1\text{-}\mu\text{F}$ capacitor, a $2\text{-}\mu\text{F}$ capacitor, and a $3\text{-}\mu\text{F}$ capacitor?
Ans. $0.545 \mu\text{F}, 0.667 \mu\text{F}, 0.75 \mu\text{F}, 1 \mu\text{F}, 1.2 \mu\text{F}, 2 \mu\text{F}, 2.2 \mu\text{F}, 2.75 \mu\text{F}, 3 \mu\text{F}, 3.67 \mu\text{F}, 4 \mu\text{F}, 5 \mu\text{F}, 6 \mu\text{F}$
- 8.44** Find the total capacitance C_T of the circuit shown in Fig. 8-19.
Ans. $2.48 \mu\text{F}$

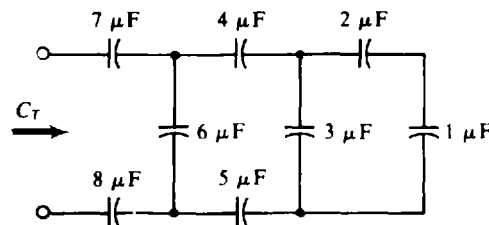

Fig. 8-19

- 8.45** A 5-, a 7-, and a $9\text{-}\mu\text{F}$ capacitor are in parallel across a 200-V source. Find the magnitude of charge stored by each capacitor and the total energy stored.
Ans. $Q_5 = 1 \text{ mC}, Q_7 = 1.4 \text{ mC}, Q_9 = 1.8 \text{ mC}, 0.42 \text{ J}$
- 8.46** A 6-, a 16-, and a $48\text{-}\mu\text{F}$ capacitor are in series with a 180-V source. Find the voltage across each capacitor and the total energy stored.
Ans. $V_6 = 120 \text{ V}, V_{16} = 45 \text{ V}, V_{48} = 15 \text{ V}, 64.8 \text{ mJ}$
- 8.47** Two capacitors are in series across a 50-V source. If one is a $1\text{-}\mu\text{F}$ capacitor with 16 V across it, what is the capacitance of the other?
Ans. $0.471 \mu\text{F}$

8.48 Find each capacitor voltage in the circuit shown in Fig. 8-20.

Ans. $V_1 = 200 \text{ V}$, $V_2 = 100 \text{ V}$, $V_3 = 40 \text{ V}$, $V_4 = 60 \text{ V}$

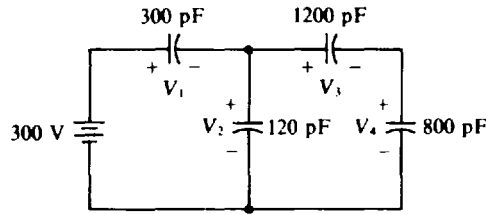

Fig. 8-20

8.49 A $0.1\text{-}\mu\text{F}$ capacitor charged to 100 V and a $0.2\text{-}\mu\text{F}$ capacitor charged to 60 V are connected together with plates of the same polarity joined. Find the voltage and the initial and final stored energies.

Ans. 73.3 V , $860 \mu\text{J}$, $807 \mu\text{J}$

8.50 Repeat Prob. 8.49 for plates of opposite polarity joined.

Ans. 6.67 V , $860 \mu\text{J}$, $6.67 \mu\text{J}$

8.51 Find the voltage across a $0.1\text{-}\mu\text{F}$ capacitor when the capacitor current is 0.5 mA .

Ans. There is not enough information to determine a unique value.

8.52 Repeat Prob. 8.51 if the capacitor voltage is 6 V at $t = 0 \text{ s}$ and if the 0.5-mA capacitor current is constant. Of course, assume associated references.

Ans. $6 + 5000t \text{ V}$

8.53 If the voltage across a $2\text{-}\mu\text{F}$ capacitor is $200t \text{ V}$ for $t \leq 1 \text{ s}$, 200 V for $1 \text{ s} \leq t \leq 5 \text{ s}$, and $3200 - 600t \text{ V}$ for $t \geq 5 \text{ s}$, find the capacitor current.

Ans. 0.4 mA for $t < 1 \text{ s}$, 0 A for $1 \text{ s} < t < 5 \text{ s}$, -1.2 mA for $t > 5 \text{ s}$

8.54 Find the time constant of the circuit shown in Fig. 8-21.

Ans. $60 \mu\text{s}$

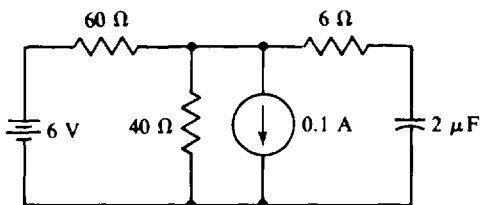

Fig. 8-21

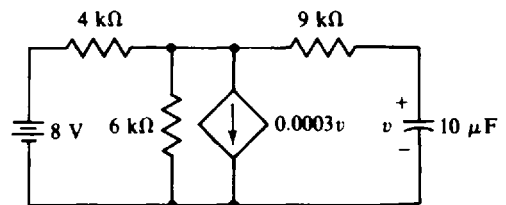

Fig. 8-22

8.55 Find the time constant of the circuit shown in Fig. 8-22.

Ans. 66.3 ms

8.56 How long does it take a $10\text{-}\mu\text{F}$ capacitor charged to 200 V to discharge through a $160\text{-k}\Omega$ resistor, and what is the total energy dissipated in the resistor?

Ans. 8 s , 0.2 J

- 8.57** At $t = 0$ s, the closing of a switch connects in series a 150-V source, a 1.6-k Ω resistor, and the parallel combination of a 1-k Ω resistor and an uncharged 0.2- μ F capacitor. Find (a) the initial capacitor current, (b) the initial and final 1-k Ω resistor currents, (c) the final capacitor voltage, and (d) the time required for the capacitor voltage to reach its final value.

Ans. (a) 93.8 mA, (b) 0 A and 57.7 mA, (c) 57.7 V, (d) 0.615 ms

- 8.58** Repeat Prob. 8.57 for a 200-V source and an initial capacitor voltage of 50 V opposed in polarity to that of the source.

Ans. (a) 43.8 mA, (b) 50 mA and 76.9 mA, (c) 76.9 V, (d) 0.615 ms

- 8.59** In the circuit shown in Fig. 8-23, find the indicated voltages and currents at $t = 0^+$ s, immediately after the switch closes. Notice that the current source is active in the circuit before the switch closes.

Ans. $v_1(0^+) = v_2(0^+) = 20$ V $i_3(0^+) = -0.106$ A
 $i_1(0^+) = 1$ A $i_4(0^+) = 0.17$ A
 $i_2(0^+) = 0.106$ A $i_5(0^+) = 63.8$ mA

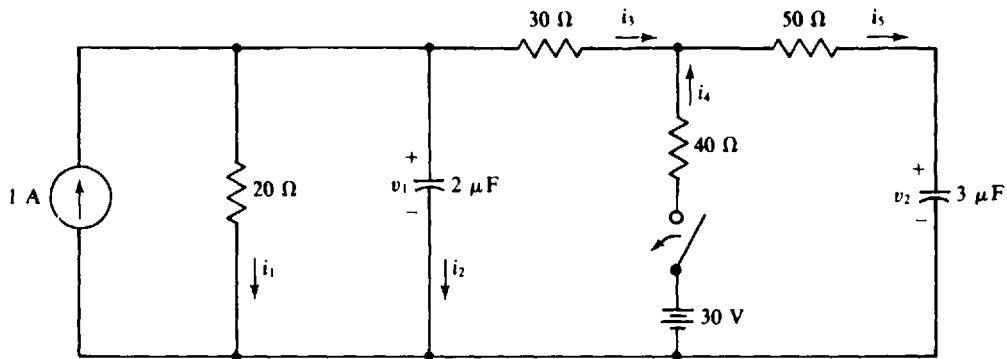

Fig. 8-23

- 8.60** In the circuit shown in Fig. 8-23, find the indicated voltages and currents a long time after the switch closes.

Ans. $v_1(\infty) = 22.2$ V $i_1(\infty) = 1.11$ A $i_3(\infty) = -0.111$ A $i_5(\infty) = 0$ A
 $v_2(\infty) = 25.6$ V $i_2(\infty) = 0$ A $i_4(\infty) = 0.111$ A

- 8.61** A 0.1- μ F capacitor, initially charged to 230 V, is discharged through a 3-M Ω resistor. Find the capacitor voltage 0.2 s after the capacitor starts to discharge.

Ans. 118 V

- 8.62** For the circuit described in Prob. 8.61, how long does it take the capacitor to discharge to 40 V?

Ans. 0.525 s

- 8.63** Closing a switch connects in series a 300-V source, a 2.7-M Ω resistor, and a 2- μ F capacitor charged to 50 V with its positive plate toward the positive terminal of the source. Find the capacitor current 3 s after the switch closes. Also, find the time required for the capacitor voltage to increase to 250 V.

Ans. 53.1 μ A, 8.69 s

- 8.64** The switch is closed at $t = 0$ s in the circuit shown in Fig. 8-24. Find v and i for $t > 0$ s. The capacitor is initially uncharged.

Ans. $60(1 - e^{-2t})$ V, $1 - 0.4e^{-2t}$ mA

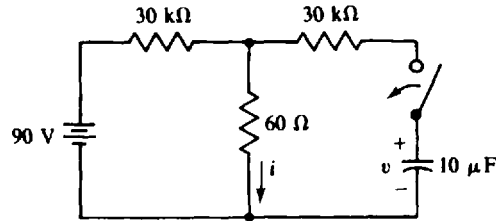

Fig. 8-24

8.65 Repeat Prob. 8.64 for $v(0^+) = 20 \text{ V}$ and for the $60\text{-k}\Omega$ resistor replaced by a $70\text{-k}\Omega$ resistor.

Ans. $63 - 43e^{-1.96t} \text{ V}$, $0.9 - 0.253e^{-1.96t} \text{ mA}$

8.66 After a long time in position 1, the switch in the circuit shown in Fig. 8-25 is thrown to position 2 for 2 s, after which it is returned to position 1. Find v for $t \geq 0 \text{ s}$.

Ans. $-200 + 300e^{-0.1t} \text{ V}$ for $0 \text{ s} \leq t \leq 2 \text{ s}$; $100 - 54.4e^{-0.2(t-2)} = 100 - 81.1e^{-0.2t} \text{ V}$ for $t \geq 2 \text{ s}$

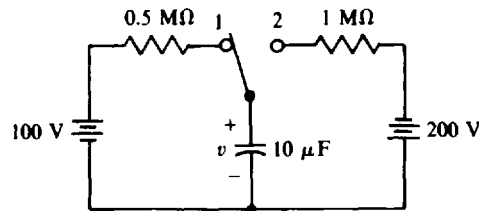

Fig. 8-25

8.67 After a long time in position 2, the switch in the circuit shown in Fig. 8-25 is thrown at $t = 0 \text{ s}$ to position 1 for 4 s, after which it is returned to position 2. Find v for $t \geq 0 \text{ s}$.

Ans. $100 - 300e^{-0.2t} \text{ V}$ for $0 \text{ s} \leq t \leq 4 \text{ s}$; $-200 + 165e^{-0.1(t-4)} = -200 + 246e^{-0.1t} \text{ V}$ for $t \geq 4 \text{ s}$

8.68 A simple RC timer has a 50-V source, a switch, an uncharged $1\text{-}\mu\text{F}$ capacitor, and a resistor, all in series. Closing the switch and then opening it 5 s later produces a capacitor voltage of 3 V. Find the resistance of the resistor.

Ans. $83.3 \text{ M}\Omega$ approximately, $80.8 \text{ M}\Omega$ more exactly

8.69 Repeat Prob. 8.68 for a capacitor voltage of 40 V.

Ans. $3.11 \text{ M}\Omega$

8.70 In the oscillator circuit shown in Fig. 8-18, replace the $1\text{-M}\Omega$ resistor with a $4.3\text{-M}\Omega$ resistor and the 1000-V source with a 150-V source and find the period of oscillation.

Ans. 7.29 s

Inductors, Inductance, and PSpice Transient Analysis

INTRODUCTION

The following material on inductors and inductance is similar to that on capacitors and capacitance presented in Chap. 8. The reason for this similarity is that, mathematically speaking, the capacitor and inductor formulas are the same. Only the symbols differ. Where one has v , the other has i , and vice versa; where one has the capacitance quantity symbol C , the other has the inductance quantity symbol L ; and where one has R , the other has G . It follows then that the basic inductor voltage-current formula is $v = L di/dt$ in place of $i = C dv/dt$, that the energy stored is $\frac{1}{2}Li^2$ instead of $\frac{1}{2}Cv^2$, that inductor currents, instead of capacitor voltages, cannot jump, that inductors are short circuits, instead of open circuits, to dc, and that the time constant is $LG = L/R$ instead of CR . Although it is possible to approach the study of inductor action on the basis of this duality, the standard approach is to use magnetic flux.

This chapter also includes material on using PSpice to analyze transient circuits.

MAGNETIC FLUX

Magnetic phenomena are explained using *magnetic flux*, or just flux, which relates to magnetic lines of force that, for a magnet, extend in continuous lines from the magnetic north pole to the south pole outside the magnet and from the south pole to the north pole inside the magnet, as is shown in Fig. 9-1a. The SI unit of flux is the *weber*, with unit symbol Wb. The quantity symbol is Φ for a constant flux and ϕ for a time-varying flux.

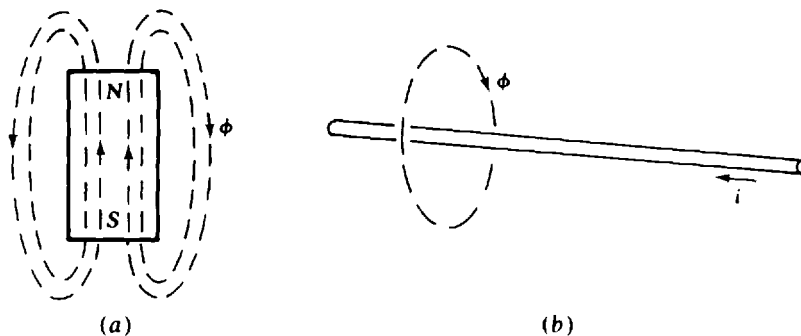

Fig. 9-1

Current flowing in a wire also produces flux, as shown in Fig. 9-1b. The relation between the direction of flux and the direction of current can be remembered from one version of the *right-hand rule*. If the thumb of the right hand is placed along the wire in the direction of the current flow, the four fingers of the right hand curl in the direction of the flux about the wire. Coiling the wire enhances the flux, as does placing certain material, called *ferromagnetic material*, in and around the coil. For example, a current flowing in a coil wound on an iron cylindrical core produces more flux than the same current flowing in an identical coil wound on a plastic cylinder.

Permeability, with quantity symbol μ , is a measure of this flux-enhancing property. It has an SI unit of *henry per meter* and a unit symbol of H/m. (The henry, with unit symbol H, is the SI unit of inductance.) The permeability of vacuum, designated by μ_0 , is $0.4\pi \mu\text{H/m}$. Permeabilities of other materials are related

to that of vacuum by a factor called the *relative permeability*, with symbol μ_r . The relation is $\mu = \mu_r \mu_0$. Most materials have relative permeabilities close to 1, but pure iron has them in the range of 6000 to 8000, and nickel has them in the range of 400 to 1000. Permalloy, an alloy of 78.5 percent nickel and 21.5 percent iron, has a relative permeability of over 80 000.

If a coil of N turns is linked by a ϕ amount of flux, this coil has a flux linkage of $N\phi$. Any change in flux linkages induces a voltage in the coil of

$$v = \lim_{\Delta t \rightarrow 0} \frac{\Delta N\phi}{\Delta t} = \frac{d}{dt}(N\phi) = N \frac{d\phi}{dt}$$

This is known as *Faraday's law*. The voltage polarity is such that any current resulting from this voltage produces a flux that opposes the original change in flux.

INDUCTANCE AND INDUCTOR CONSTRUCTION

For most coils, a current i produces a flux linkage $N\phi$ that is proportional to i . The equation relating $N\phi$ and i has a constant of proportionality L that is the quantity symbol for the *inductance* of the coil. Specifically, $Li = N\phi$ and $L = N\phi / i$. The SI unit of inductance is the *henry*, with unit symbol H. A component designed to be used for its inductance property is called an *inductor*. The terms “coil” and “choke” are also used. Figure 9-2 shows the circuit symbol for an inductor.

The inductance of a coil depends on the shape of the coil, the permeability of the surrounding material, the number of turns, the spacing of the turns, and other factors. For the single-layer coil shown in Fig. 9-3, the inductance is approximately $L = N^2 \mu A / l$, where N is the number of turns of wire, A is the core cross-sectional area in square meters, l is the coil length in meters, and μ is the core permeability. The greater the length to diameter, the more accurate the formula. For a length of 10 times the diameter, the actual inductance is 4 percent less than the value given by the formula.



Fig. 9-2

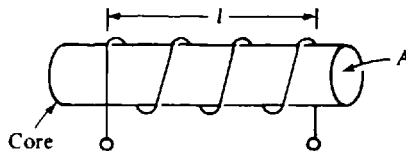

Fig. 9-3

INDUCTOR VOLTAGE AND CURRENT RELATION

Inductance instead of flux is used in analyzing circuits containing inductors. The equation relating inductor voltage, current, and inductance can be found from substituting $N\phi = Li$ into $v = d(N\phi)/dt$. The result is $v = L di/dt$, with associated references assumed. If the voltage and current references are not associated, a negative sign must be included. Notice that the voltage at any instant depends on the rate of change of inductor current at that instant, but not at all on the value of current then.

One important fact from $v = L di/dt$ is that if an inductor current is constant, not changing, then the inductor voltage is zero because $di/dt = 0$. With a current flowing through it, but zero voltage across it, an inductor acts as a short circuit: *An inductor is a short circuit to dc*. Remember, though, that it is only after an inductor current becomes constant that an inductor acts as a short circuit.

The relation $v = L di/dt \approx L\Delta i / \Delta t$ also means that *an inductor current cannot jump*. For a jump to occur, Δi would be nonzero while Δt was zero, with the result that $\Delta i / \Delta t$ would be infinite, making the inductor voltage infinite. In other words, a jump in inductor current requires an infinite inductor voltage. But, of course, there are no sources of infinite voltage. Inductor voltage has no similar restriction. It can jump or even change polarity instantaneously. Inductor currents not jumping means that inductor

currents immediately after a switching operation are the same as immediately before the operation. This is an important fact for RL (resistor-inductor) circuit analysis.

TOTAL INDUCTANCE

The total or equivalent inductance (L_T or L_{eq}) of inductors connected in series, as in the circuit shown in Fig. 9-4a, can be found from KVL: $v_s = v_1 + v_2 + v_3$. Substituting from $v = L di/dt$ results in

$$L_T \frac{di}{dt} = L_1 \frac{di}{dt} + L_2 \frac{di}{dt} + L_3 \frac{di}{dt}$$

which upon division by di/dt reduces to $L_T = L_1 + L_2 + L_3$. Since the number of series inductors is not significant in this derivation, the result can be generalized to any number of series inductors:

$$L_T = L_1 + L_2 + L_3 + L_4 + \dots$$

which specifies that the total or equivalent inductance of series inductors is equal to the sum of the individual inductances.

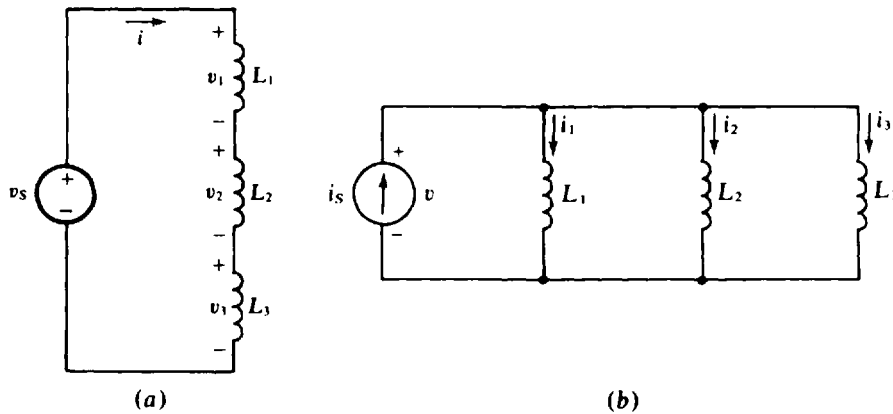

Fig. 9-4

The total inductance of inductors connected in parallel, as in the circuit shown in Fig. 9-4b, can be found starting with the voltage-current equation at the source terminals: $v = L_T di_s/dt$, and substituting in $i_s = i_1 + i_2 + i_3$:

$$v = L_T \frac{d}{dt} (i_1 + i_2 + i_3) = L_T \left(\frac{di_1}{dt} + \frac{di_2}{dt} + \frac{di_3}{dt} \right)$$

Each derivative can be eliminated using the appropriate $di/dt = v/L$:

$$v = L_T \left(\frac{v}{L_1} + \frac{v}{L_2} + \frac{v}{L_3} \right) \quad \text{or} \quad \frac{1}{L_T} = \frac{1}{L_1} + \frac{1}{L_2} + \frac{1}{L_3}$$

which can also be written as

$$L_T = \frac{1}{1/L_1 + 1/L_2 + 1/L_3}$$

Generalizing,

$$L_T = \frac{1}{1/L_1 + 1/L_2 + 1/L_3 + 1/L_4 + \dots}$$

which specifies that the total inductance of parallel inductors equals the reciprocal of the sum of the reciprocals of the individual inductances. For the special case of N parallel inductors having the same inductance L , this formula simplifies to $L_T = L/N$. And for two parallel inductors it is $L_T = L_1 L_2 / (L_1 + L_2)$. Notice that the formulas for finding total inductances are the same as those for finding total resistances.

ENERGY STORAGE

As can be shown by using calculus, the energy stored in an inductor is

$$w_L = \frac{1}{2} Li^2$$

in which w_L is in joules, L is in henries, and i is in amperes. This energy is considered to be stored in the magnetic field surrounding the inductor.

SINGLE-INDUCTOR DC-EXCITED CIRCUITS

When switches open or close in an RL dc-excited circuit with a single inductor, all voltages and currents that are not constant change exponentially from their initial values to their final constant values, as can be proved from differential equations. These exponential changes are the same as those illustrated in Fig. 8-5 for capacitors. Consequently, the voltage and current equations are the same: $v = v(\infty) + [v(0+) - v(\infty)]e^{-t/\tau}$ V and $i = i(\infty) + [i(0+) - i(\infty)]e^{-t/\tau}$ A. The time constant τ , though, is different. It is $\tau = L/R_{Th}$, in which R_{Th} is the circuit Thévenin resistance at the inductor terminals. Of course, in one time constant the voltages and currents change by 63.2 percent of their total changes, and after five time constants they can be considered to be at their final values.

Because of the similarity of the RL and RC equations, it is possible to make RL timers. But, practically speaking, RC timers are much better. One reason is that inductors are not nearly as ideal as capacitors because the coils have resistances that are seldom negligible. Also, inductors are relatively bulky, heavy, and difficult to fabricate using integrated-circuit techniques. Additionally, the magnetic fields extending out from the inductors can induce unwanted voltages in other components. The problems with inductors are significant enough that designers of electronic circuits often exclude inductors entirely from their circuits.

PSPICE TRANSIENT ANALYSIS

The PSpice statements for inductors and capacitors are similar to those for resistors but instead of an R, they begin with an L for an inductor and a C for a capacitor. Also, nonzero initial inductor currents and capacitor voltages must be specified in these statements. For example, the statement

```
L1 3 4 5M IC = 6M
```

specifies that inductor L1 is connected between nodes 3 and 4, that its inductance is 5 mH, and that it has an initial current of 6 mA that enters at node 3 (the first specified node). The statement

```
C2 7 2 8U IC = 9
```

specifies that capacitor C2 is connected between nodes 7 and 2, that its capacitance is 8 μ F, and that it has an initial voltage of 9 V positive at node 7 (the first specified node).

For PSpice to perform a transient analysis, the circuit file must include a statement having the form

```
.TRAN TSTEP TSTOP UIC
```

in which TSTEP and TSTOP specify times in seconds. This statement might be, for example,

```
.TRAN 0.02 4 UIC
```

in which 0.02 corresponds to TSTEP, 4 to TSTOP, and UIC to UIC, which means "use initial conditions." The TSTEP of 0.02 s is the printing or plotting increment for the printer output, and the TSTOP of 4 s is the stop time for the analysis. A good value for TSTOP is four or five time constants. For the specified TSTEP and TSTOP times, the first output printed is for $t = 0$ s, the second for $t = 0.02$ s, the third for $t = 0.04$ s, and so on up to the last one for $t = 4$ s.

The .PRINT statement for a transient analysis is the same as that for a dc analysis except that TRAN replaces DC. The resulting printout consists of a table of columns. The first column consists of the times at which the outputs are to be specified, as directed by the specifications of the .TRAN statement. The second column comprises the values of the first specified output quantity in the .PRINT statement, which values correspond to the times of the first column. The third column comprises the values of the second specified output quantity, and so on.

With a plot statement, a plot of the output quantities versus time can be obtained. A plot statement is similar to a print statement except that it begins with .PLOT instead of .PRINT.

Improved plots can be obtained by running the graphics postprocessor Probe which is a separate executable program that can be obtained with PSpice. Probe is one of the menu items of the Control Shell. If the Control Shell is not being used, the statement .PROBE must be included in the circuit file for the use of Probe. Then, the PROBE mode may be automatically entered into after the running of the PSpice program.

With Probe, various plots can be obtained by responding to the menus that appear at the bottom of the screen. These menus are fairly self-explanatory and can be mastered with a little experimentation and trial-and-error.

For transient analysis, PSpice has five special time-dependent sources, only two of which will be considered here: the *periodic-pulse source* and the *piecewise-linear source*.

Figure 9-5 shows the general form of the pulse for the periodic-pulse source. This pulse can be periodic, but does not have to be and will not be for present purposes. The parameters signify V1 for the initial value, V2 for the pulsed value, TD for time delay, TR for rise time, TF for fall time, PW for pulse width, and PER for period. For a pulse voltage source V1 that is connected between nodes 2 and 3, with the positive reference at node 2, the corresponding PSpice statement has the form

```
V1 2 3 PULSE(V1, V2, TD, TR, TF, PW, PER)
```

The commas do not have to be included. Also, if a pulse is not periodic, no PER parameter is specified. PSpice then assigns a default value, which is the TSTOP value in the .TRAN statement.

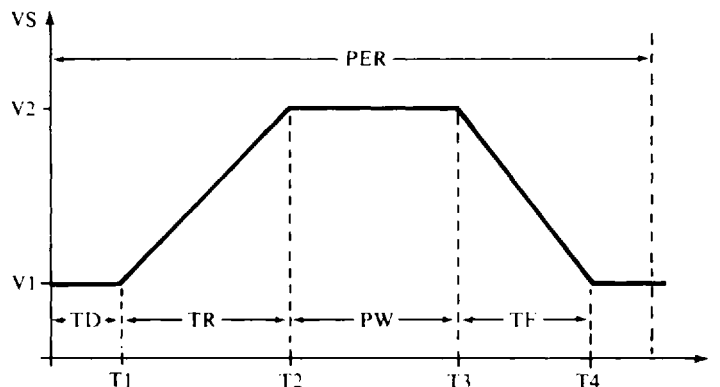

Fig. 9-5

If a zero rise or fall time is specified, PSpice will use a default value equal to the TSTEP value in the .TRAN statement. Since this value is usually too large, nonzero but insignificant rise and fall times should be specified, such as one-millionth of a time constant.

The piecewise-linear source can be used to obtain a voltage or a current that has a waveform

comprising only straight lines. It applies, for example, to the pulse of Fig. 9-5. The corresponding PSpice statement for it is

```
V1 2 3 PWL(0, V1, T1, V1, T2, V2, T3, V2, T4, V1)
```

Again, the commas are optional. The entries within the parentheses are in pairs specifying the corners of the waveform, where the first specification is time (0, T1, T2, etc.) and the second is the voltage at that time (V1, V2, V3, etc.). The times must continually increase, even if by very small increments—no two times can be exactly the same. If the last time specified in the PWL statement is less than TSTOP in the .TRAN statement, the pulse remains at its last specified value until the TSTOP time.

PWL statements can be used to obtain sources of voltage and current that have a much greater variety of waveforms than those that can be obtained with PULSE statements. However, PULSE statements apply to periodic waveforms while PWL statements do not.

Solved Problems

- 9.1** Find the voltage induced in a 50-turn coil from a constant flux of 10^4 Wb, and also from a changing flux of 3 Wb/s.

A constant flux linking a coil does not induce any voltage—only a changing flux does. A changing flux of 3 Wb/s induces a voltage of $v = N d\phi/dt = 50 \times 3 = 150$ V.

- 9.2** What is the rate of change of flux linking a 200-turn coil when 50 V is across the coil?

This rate of change is the $d\phi/dt$ in $v = N d\phi/dt$:

$$\frac{d\phi}{dt} = \frac{v}{N} = \frac{50}{200} = 0.25 \text{ Wb/s}$$

- 9.3** Find the number of turns of a coil for which a change of 0.4 Wb/s of flux linking the coil induces a coil voltage of 20 V.

This number of turns is the N in $v = N d\phi/dt$:

$$N = \frac{v}{d\phi/dt} = \frac{20}{0.4} = 50 \text{ turns}$$

- 9.4** Find the inductance of a 100-turn coil that is linked by 3×10^{-4} Wb when a 20-mA current flows through it.

The pertinent formula is $Li = N\phi$. Thus,

$$L = \frac{N\phi}{i} = \frac{100(3 \times 10^{-4})}{20 \times 10^{-3}} = 1.5 \text{ H}$$

- 9.5** Find the approximate inductance of a single-layer coil that has 300 turns wound on a plastic cylinder 12 cm long and 0.5 cm in diameter.

The relative permeability of plastic is so nearly 1 that the permeability of vacuum can be used in the inductance formula for a single-layer cylindrical coil:

$$L = \frac{N^2 \mu A}{l} = \frac{300^2 (0.4\pi \times 10^{-6}) [\pi \times (0.25 \times 10^{-2})^2]}{12 \times 10^{-2}} \text{ H} = 18.5 \mu\text{H}$$

- 9.6** Find the approximate inductance of a single-layer 50-turn coil that is wound on a ferromagnetic cylinder 1.5 cm long and 1.5 mm in diameter. The ferromagnetic material has a relative permeability of 7000.

$$L = \frac{N^2 \mu A}{l} = \frac{50^2 (7000 \times 0.4\pi \times 10^{-6}) [\pi \times (0.75 \times 10^{-3})^2]}{1.5 \times 10^{-2}} \text{ H} = 2.59 \text{ mH}$$

- 9.7** A 3-H inductor has 2000 turns. How many turns must be added to increase the inductance to 5 H?
In general, inductance is proportional to the square of the number of turns. By this proportionality,

$$\frac{5}{3} = \frac{N^2}{2000^2} \quad \text{or} \quad N = 2000 \sqrt{\frac{5}{3}} = 2582 \text{ turns}$$

So, $2582 - 2000 = 582$ turns must be added without making any other changes.

- 9.8** Find the voltage induced in a 150-mH coil when the current is constant at 4 A. Also, find the voltage when the current is changing at a rate of 4 A/s.

If the current is constant, $di/dt = 0$ and so the coil voltage is zero. For a rate of change of $di/dt = 4$ A/s,

$$v = L \frac{di}{dt} = (150 \times 10^{-3})(4) = 0.6 \text{ V}$$

- 9.9** Find the voltage induced in a 200-mH coil at $t = 3$ ms if the current increases uniformly from 30 mA at $t = 2$ ms to 90 mA at $t = 5$ ms.

Because the current increases uniformly, the induced voltage is constant over the time interval. The rate of increase is $\Delta i/\Delta t$, where Δi is the current at the end of the time interval minus the current at the beginning of the time interval: $90 - 30 = 60$ mA. Of course, Δt is the time interval: $5 - 2 = 3$ ms. The voltage is

$$v = L \frac{\Delta i}{\Delta t} = \frac{(200 \times 10^{-3})(60 \times 10^{-3})}{3 \times 10^{-3}} = 4 \text{ V} \quad \text{for} \quad 2 \text{ ms} < t < 5 \text{ ms}$$

- 9.10** What is the inductance of a coil for which a changing current increasing uniformly from 30 mA to 80 mA in 100 μ s induces 50 mV in the coil?

Because the increase is uniform (linear), the time derivative of the current equals the quotient of the current change and the time interval:

$$\frac{di}{dt} = \frac{\Delta i}{\Delta t} = \frac{80 \times 10^{-3} - 30 \times 10^{-3}}{100 \times 10^{-6}} = 500 \text{ A/s}$$

Then, from $v = L di/dt$,

$$L = \frac{v}{di/dt} = \frac{50 \times 10^{-3}}{500} \text{ H} = 100 \mu\text{H}$$

- 9.11** Find the voltage induced in a 400-mH coil from 0 s to 8 ms when the current shown in Fig. 9-6 flows through the coil.

The approach is to find di/dt , the slope, from the graph and insert it into $v = L di/dt$ for the various time intervals. For the first millisecond, the current decreases uniformly from 0 A to -40 mA. So, the slope is $(-40 \times 10^{-3} - 0)/(1 \times 10^{-3}) = -40$ A/s, which is the change in current divided by the corresponding change in time. The resulting voltage is $v = L di/dt = (400 \times 10^{-3})(-40) = -16$ V. For the next three milliseconds, the slope is $[20 \times 10^{-3} - (-40 \times 10^{-3})]/(3 \times 10^{-3}) = 20$ A/s and the voltage is $v =$

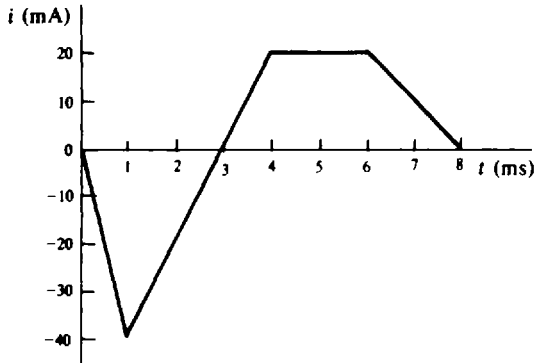

Fig. 9-6

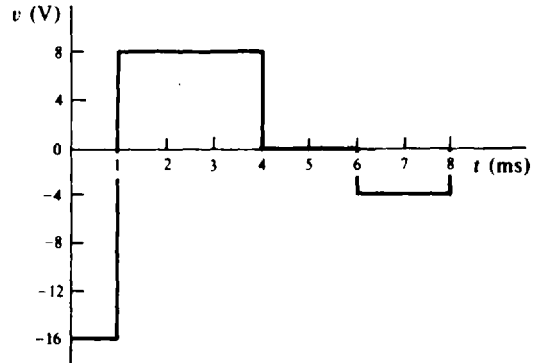

Fig. 9-7

$(400 \times 10^{-3})(20) = 8 \text{ V}$. For the next two milliseconds, the current graph is horizontal, which means that the slope is zero. Consequently, the voltage is zero: $v = 0 \text{ V}$. For the last two milliseconds, the slope is $(0 - 20 \times 10^{-3})/(2 \times 10^{-3}) = -10 \text{ A s}^{-1}$ and $v = (400 \times 10^{-3})(-10) = -4 \text{ V}$.

Figure 9-7 shows the graph of voltage. Notice that the inductor voltage can jump and can even instantaneously change polarity.

- 9.12 Find the total inductance of three parallel inductors having inductances of 45, 60, and 75 mH.

$$L_T = \frac{1}{\frac{1}{45} + \frac{1}{60} + \frac{1}{75}} = 19.1 \text{ mH}$$

- 9.13 Find the inductance of the inductor that when connected in parallel with a 40-mH inductor produces a total inductance of 10 mH.

As has been derived, the reciprocal of the total inductance equals the sum of the reciprocals of the inductances of the individual parallel inductors:

$$\frac{1}{10} = \frac{1}{40} + \frac{1}{L} \quad \text{from which} \quad \frac{1}{L} = 0.075 \quad \text{and} \quad L = 13.3 \text{ mH}$$

- 9.14 Find the total inductance L_T of the circuit shown in Fig. 9-8.

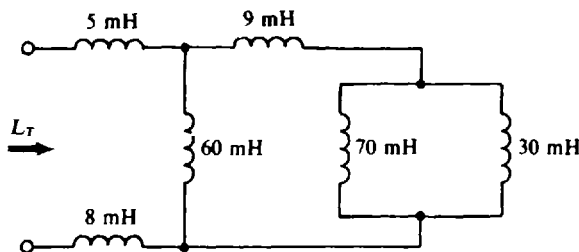

Fig. 9-8

The approach, of course, is to combine inductances starting with inductors at the end opposite the terminals at which L_T is to be found. There, the parallel 70- and 30-mH inductors have a total inductance of $70(30)/(70 + 30) = 21 \text{ mH}$. This adds to the inductance of the 9-mH series inductor: $21 + 9 = 30 \text{ mH}$. This combines with the inductance of the parallel 60-mH inductor: $60(30)/(60 + 30) = 20 \text{ mH}$. And, finally, this adds with the inductances of the series 5- and 8-mH inductors: $L_T = 20 + 5 + 8 = 33 \text{ mH}$.

- 9.15** Find the energy stored in a 200-mH inductor that has 10 V across it.

Not enough information is given to determine the stored energy. The inductor current is needed, not the voltage, and there is no way of finding this current from the specified voltage.

- 9.16** A current $i = 0.32t$ A flows through a 150-mH inductor. Find the energy stored at $t = 4$ s.

At $t = 4$ s the inductor current is $i = 0.32 \times 4 = 1.28$ A, and so the stored energy is

$$w = \frac{1}{2}Li^2 = 0.5(150 \times 10^{-3})(1.28)^2 = 0.123 \text{ J}$$

- 9.17** Find the time constant of the circuit shown in Fig. 9-9.

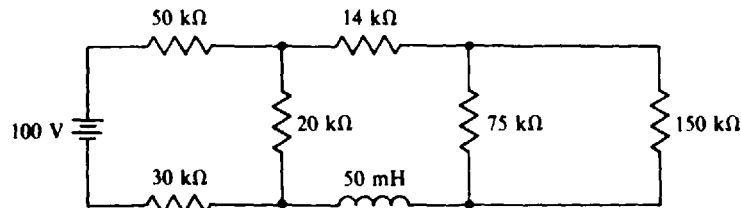

Fig. 9-9

The time constant is L/R_{Th} , where R_{Th} is the Thévenin resistance of the circuit at the inductor terminals. For this circuit,

$$R_{Th} = (50 + 30) \parallel 20 + 14 + 75 \parallel 150 = 80 \text{ k}\Omega$$

and so $\tau = (50 \times 10^{-3}) / (80 \times 10^3) \text{ s} = 0.625 \mu\text{s}$.

- 9.18** What is the energy stored in the inductor of the circuit shown in Fig. 9-9?

The inductor current is needed. Presumably, the circuit has been constructed long enough ($5\tau = 5 \times 0.625 = 3.13 \mu\text{s}$) for the inductor current to become constant and so for the inductor to be a short circuit. The current in this short circuit can be found from Thévenin's resistance and voltage. The Thévenin resistance is $80 \text{ k}\Omega$, as found in the solution to Prob. 9.17. The Thévenin voltage is the voltage across the $20\text{-k}\Omega$ resistor if the inductor is replaced by an open circuit. This voltage will appear across the open circuit since the $14\text{-k}\Omega$, $75\text{-k}\Omega$, and $150\text{-k}\Omega$ resistors will not carry any current. By voltage division, this voltage is

$$V_{Th} = \frac{20}{20 + 50 + 30} \times 100 = 20 \text{ V}$$

Because of the short-circuit inductor load, the inductor current is $V_{Th} / (R_{Th} + 0) = 20 / 80 = 0.25 \text{ mA}$, and the stored energy is $0.5(50 \times 10^{-3})(0.25 \times 10^{-3})^2 \text{ J} = 1.56 \text{ nJ}$.

- 9.19** Closing a switch connects in series a 20-V source, a $2\text{-}\Omega$ resistor, and a 3.6-H inductor. How long does it take the current to get to its maximum value, and what is this value?

The current reaches its maximum value five time constants after the switch closes: $5L/R = 5(3.6)/2 = 9 \text{ s}$. Since the inductor acts as a short circuit at that time, only the resistance limits the current: $i(\infty) = 20/2 = 10 \text{ A}$.

- 9.20** Closing a switch connects in series a 21-V source, a $3\text{-}\Omega$ resistor, and a 2.4-H inductor. Find (a) the initial and final currents, (b) the initial and final inductor voltages, and (c) the initial rate of current increase.

- (a) Immediately after the switch closes, the inductor current is 0 A because it was 0 A immediately before the switch closed, and an inductor current cannot jump. The current increases from 0 A until it reaches its maximum value five time constants ($5 \times 2.4 \text{ s} = 4 \text{ s}$) after the switch closes. Then, because the current is constant, the inductor becomes a short circuit, and so $i(\infty) = V/R = 21/3 = 7 \text{ A}$.
- (b) Since the current is zero immediately after the switch closes, the resistor voltage is 0 V, which means, by KVL, that all the source voltage is across the inductor: The initial inductor voltage is 21 V. Of course, the final inductor voltage is zero because the inductor is a short circuit to dc after five time constants.
- (c) As can be seen from Fig. 8-5b, the current initially increases at a rate such that the final current value would be reached in one time constant if the rate did not change. This initial rate is

$$\frac{i(\infty) - i(0+)}{\tau} = \frac{7 - 0}{0.8} = 8.75 \text{ A/s}$$

Another way of finding this initial rate, which is di/dt at $t = 0+$, is from the initial inductor voltage:

$$v_L(0+) = L \frac{di}{dt}(0+) \quad \text{or} \quad \frac{di}{dt}(0+) = \frac{v_L(0+)}{L} = \frac{21}{2.4} = 8.75 \text{ A/s}$$

9.21 A closed switch connects a 120-V source to the field coils of a dc motor. These coils have 6 H of inductance and 30Ω of resistance. A discharge resistor in parallel with the coil limits the maximum coil and switch voltages at the instants at which the switch is opened. Find the maximum value of the discharge resistor that will prevent the coil voltage from exceeding 300 V.

With the switch closed, the current in the coils is $120/30 = 4 \text{ A}$ because the inductor part of the coils is a short circuit. Immediately after the switch is opened, the current must still be 4 A because an inductor current cannot jump—the magnetic field about the coil will change to produce whatever coil voltage is necessary to maintain this 4 A. In fact, if the discharge resistor were not present, this voltage would become great enough—thousands of volts—to produce arcing at the switch contacts to provide a current path to enable the current to decrease continuously. Such a large voltage might be destructive to the switch contacts and to the coil insulation. The discharge resistor provides an alternative path for the inductor current, which has a maximum value of 4 A. To limit the coil voltage to 300 V, the maximum value of discharge resistance is $300/4 = 75 \Omega$. Of course, any value less than 75Ω will limit the voltage to less than 300 V, but a smaller resistance will result in more power dissipation when the switch is closed.

9.22 In the circuit shown in Fig. 9-10, find the indicated currents a long time after the switch has been in position 1.

The inductor is, of course, a short circuit, and shorts out the $20\text{-}\Omega$ resistor. As a result, $i_1 = 0 \text{ A}$. This short circuit also places the $18\text{-}\Omega$ resistor in parallel with the $12\text{-}\Omega$ resistor. Together they have a total resistance of $18(12)/(18 + 12) = 7.2 \Omega$. This adds to the resistance of the series $6.8\text{-}\Omega$ resistor to produce

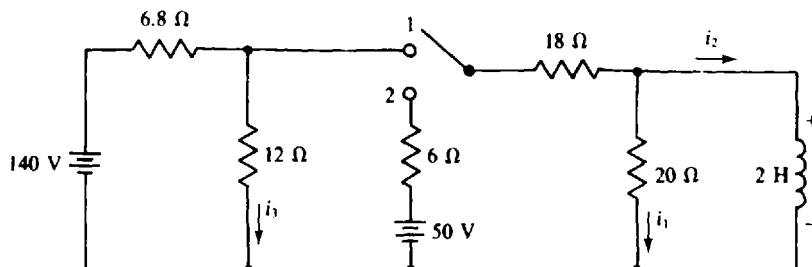

Fig. 9-10

$7.2 + 6.8 = 14 \Omega$ at the source terminals. So, the source current is $140/14 = 10$ A. By current division,

$$i_2 = \frac{12}{12 + 18} \times 10 = 4 \text{ A} \quad \text{and} \quad i_3 = \frac{18}{12 + 18} \times 10 = 6 \text{ A}$$

9.23 For the circuit shown in Fig. 9-10, find the indicated voltage and currents immediately after the switch is thrown to position 2 from position 1, where it has been a long time.

As soon as the switch leaves position 1, the left-hand side of the circuit is isolated, becoming a series circuit in which $i_3 = 140/(6.8 + 12) = 7.45$ A. In the other part of the circuit, the inductor current cannot jump, and is 4 A, as was found in the solution to Prob. 9.22: $i_2 = 4$ A. Since this is a known current, it can be considered to be from a current source, as shown in Fig. 9-11. Remember, though, that this circuit is valid only for the one instant of time immediately after the switch is thrown to position 2. By nodal analysis,

$$\frac{v}{20} + \frac{v - 50}{6 + 18} + 4 = 0 \quad \text{from which} \quad v = -20.9 \text{ V}$$

And $i_1 = v/20 = -20.9/20 = -1.05$ A.

This technique of replacing inductors in a circuit by current sources is completely general for an analysis at an instant of time immediately after a switching operation. (Similarly, capacitors can be replaced by voltage sources.) Of course, if an inductor current is zero, then the current source carries 0 A and so is equivalent to an open circuit.

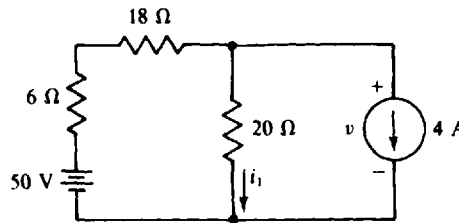

Fig. 9-11

9.24 A short is placed across a coil that at the time is carrying 0.5 A. If the coil has an inductance of 0.5 H and a resistance of 2Ω , what is the coil current 0.1 s after the short is applied?

The current equation is needed. For the basic formula $i = i(\infty) + [i(0+) - i(\infty)]e^{-t/\tau}$, the initial current is $i(0+) = 0.5$ A because the inductor current cannot jump, the final current is $i(\infty) = 0$ A because the current will decay to zero after all the initially stored energy is dissipated in the resistance, and the time constant is $\tau = L/R = 0.5/2 = 0.25$ s. So,

$$i(t) = 0 + (0.5 - 0)e^{-t/0.25} = 0.5e^{-4t} \text{ A}$$

and $i(0.1) = 0.5e^{-4(0.1)} = 0.335$ A.

9.25 A coil for a relay has a resistance of 30Ω and an inductance of 2 H. If the relay requires 250 mA to operate, how soon will it operate after 12 V is applied to the coil?

For the current formula, $i(0+) = 0$ A, $i(\infty) = 12/30 = 0.4$ A, and $\tau = 2/30 = 1/15$ s. So,

$$i = 0.4 + (0 - 0.4)e^{-15t} = 0.4(1 - e^{-15t}) \text{ A}$$

The time at which the current is 250 mA = 0.25 A can be found by substituting 0.25 for i and solving for t :

$$0.25 = 0.4(1 - e^{-15t}) \quad \text{or} \quad e^{-15t} = 0.375$$

Taking the natural logarithm of both sides results in

$$\ln e^{-15t} = \ln 0.375 \quad \text{from which} \quad -15t = -0.9809 \quad \text{and} \quad t = 65.4 \text{ ms}$$

- 9.26** For the circuit shown in Fig. 9-12, find v and i for $t > 0$ s if at $t = 0$ s the switch is thrown to position 2 after having been in position 1 for a long time.

The switch shown is a make-before-break switch that makes contact at the beginning of position 2 before breaking contact at position 1. This temporary double contacting provides a path for the inductor current during switching and prevents arcing at the switch contacts. To find the voltage and current, it is only necessary to get their initial and final values, along with the time constant, and insert these into the voltage and current formulas. The initial current $i(0+)$ is the same as the inductor current immediately before the switching operation, with the switch in position 1: $i(0+) = 50/(4 + 6) = 5$ A. When the switch is in position 2, this current produces initial voltage drops of $5 \times 6 = 30$ V and $14 \times 5 = 70$ V across the 6- and 14- Ω resistors, respectively. By KVL, $30 + 70 + v(0+) = 20$, from which $v(0+) = -80$ V. For the final values, clearly $v(\infty) = 0$ V and $i(\infty) = 20/(14 + 6) = 1$ A. The time constant is $4/20 = 0.2$ s. With these values inserted, the voltage and current formulas are

$$v = 0 + (-80 - 0)e^{-t/0.2} = -80e^{-5t} \text{ V} \quad \text{for } t > 0 \text{ s}$$

$$i = 1 + (5 - 1)e^{-t/0.2} = 1 + 4e^{-5t} \text{ A} \quad \text{for } t \geq 0 \text{ s}$$

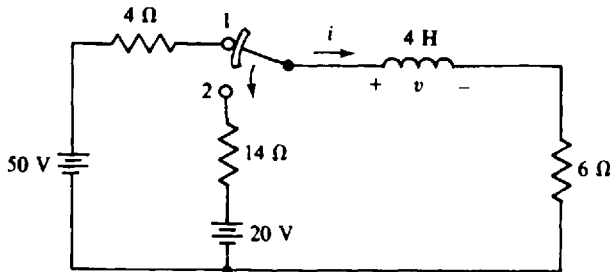

Fig. 9-12

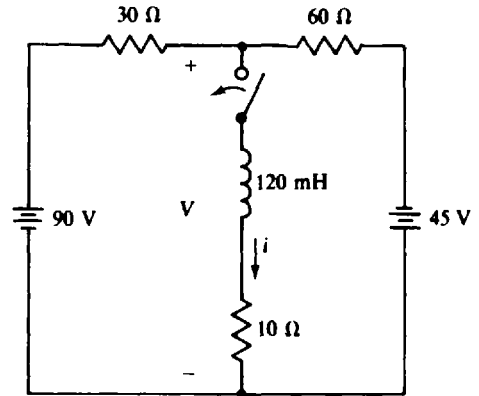

Fig. 9-13

- 9.27** For the circuit shown in Fig. 9-13, find i for $t \geq 0$ s if the switch is closed at $t = 0$ s after being open for a long time.

A good approach is to use the Thévenin equivalent circuit at the inductor terminals. The Thévenin resistance is easy to find because the resistors are in series-parallel when the sources are deactivated: $R_{Th} = 10 + 30 \parallel 60 = 30 \Omega$. The Thévenin voltage is the indicated V with the center branch removed because replacing the inductor by an open circuit prevents the center branch from affecting this voltage. By nodal analysis,

$$\frac{V - 90}{30} + \frac{V - (-45)}{60} = 0 \quad \text{from which} \quad V = 45 \text{ V}$$

So, the Thévenin equivalent circuit is a 30- Ω resistor in series with a 45-V source, and the polarity of the source is such as to produce a positive current i . With the Thévenin circuit connected to the inductor, it should be obvious that $i(0+) = 0$ A, $i(\infty) = 45/30 = 1.5$ A, $\tau = (120 \times 10^{-3})/30 = 4 \times 10^{-3}$ s, and $1/\tau = 250$. These values inserted into the current formula result in $i = 1.5 - 1.5e^{-250t}$ A for $t \geq 0$ s.

- 9.28** In the circuit shown in Fig. 9-14, switch S_1 is closed at $t = 0$ s, and switch S_2 is opened at $t = 3$ s. Find $i(2)$ and $i(4)$, and make a sketch of i for $t \geq 0$ s.

Two equations for i are needed: one with both switches closed, and the other with switch S_1 closed and switch S_2 open. At the time that S_1 is closed, $i(0+) = 0$ A, and i starts increasing toward a final value of $i(\infty) = 6/(0.1 + 0.2) = 20$ A. The time constant is $1.2/(0.1 + 0.2) = 4$ s. The 1.2- Ω resistor does not affect

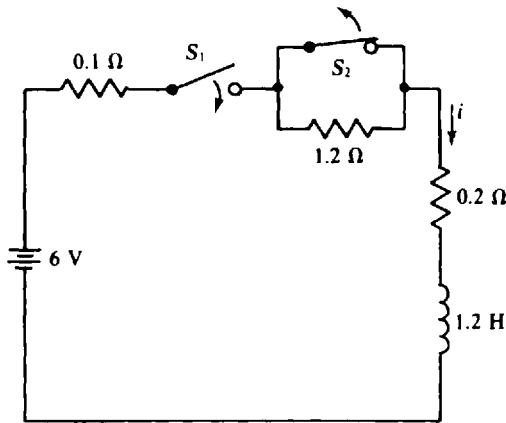

Fig. 9-14

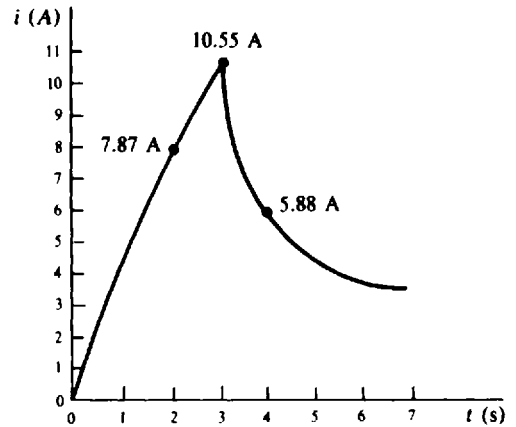

Fig. 9-15

the current or time constant because this resistor is shorted by switch S_2 . So, for the first three seconds, $i = 20 - 20e^{-t/4}$ A, and from this, $i(2) = 20 - 20e^{-2/4} = 7.87$ A.

After switch S_2 opens at $t = 3$ s, the equation for i must change because the circuit changes as a result of the insertion of the $1.2\text{-}\Omega$ resistor. With the switching occurring at $t = 3$ s instead of at $t = 0$ s, the basic formula for i is $i = i(\infty) + [i(3+) - i(\infty)]e^{-(t-3)/\tau}$ A. The current $i(3+)$ can be calculated from the first i equation since the current cannot jump at $t = 3$ s: $i(3+) = 20 - 20e^{-3/4} = 10.55$ A. Of course, $i(\infty) = 6/(0.1 + 1.2 + 0.2) = 4$ A and $\tau = 1.2 \cdot 1.5 = 0.8$ s. With these values inserted, the current formula is

$$i = 4 + (10.55 - 4)e^{-(t-3)/0.8} = 4 + 6.55e^{-1.25(t-3)} \text{ A} \quad \text{for } t \geq 3 \text{ s}$$

from which $i(4) = 4 + 6.55e^{-1.25(4-3)} = 5.88$ A.

Figure 9-15 shows the graph of current based on the two current equations.

9.29 Use PSpice to find the current i in the circuit of Fig. 9-16.

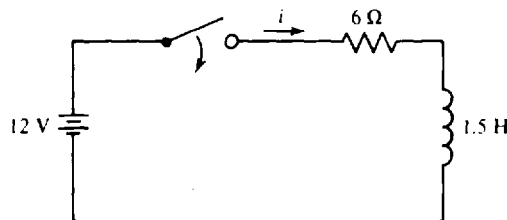
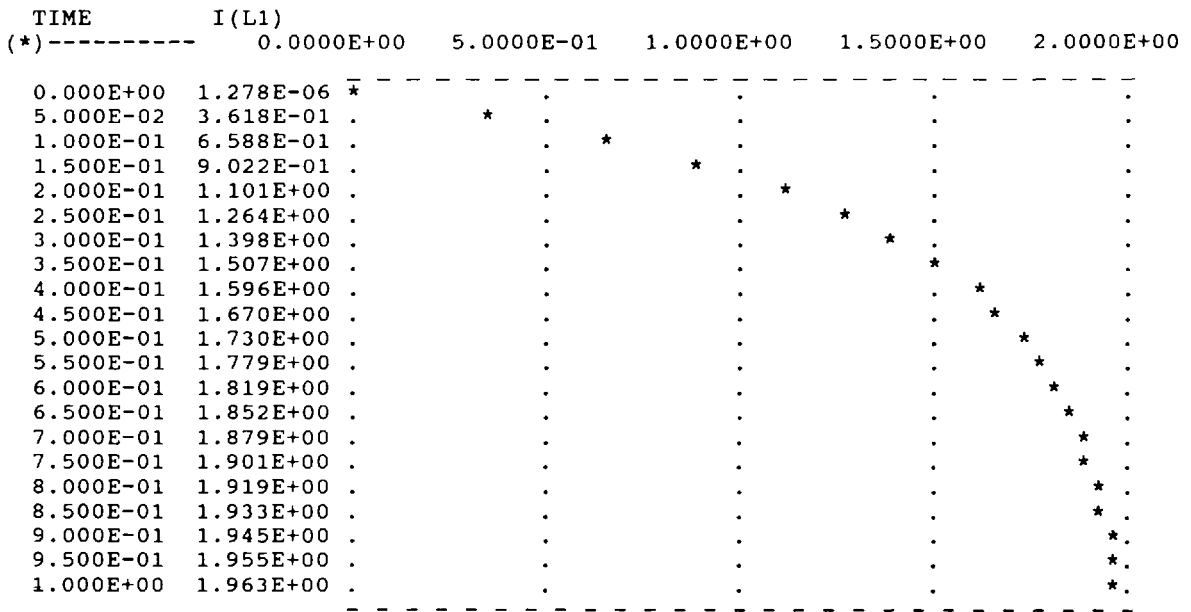

Fig. 9-16

The time constant is $\tau = L/R = 1.5/6 = 0.25$ s. So, a suitable value for TSTOP in the .TRAN statement is $4\tau = 1$ s because the current is at approximately its final value then. The number of time steps will be selected as only 20, for convenience. Then, TSTEP in the .TRAN statement is TSTOP/20 = 0.05 s. Even though the initial inductor current is zero, a UIC specification is needed in the .TRAN statement. Otherwise, only the final value of 2 A will be obtained. A .PLOT statement will be included to obtain a plot. Because a table of values will automatically be obtained with this plot, no .PRINT statement is needed. Probe will also be used to obtain a plot to demonstrate the superiority of its plot. Following is a suitable circuit file.

```
CIRCUIT FILE FOR THE CIRCUIT OF FIG. 9-16
V1 1 0 DC 12
R1 1 2 6
L1 2 0 1.5
.TRAN 0.05 1 UIC
.PLOT TRAN I(L1)
.PROBE
.END
```

When PSpice is run with this circuit file, the plots of Figs. 9-17a and 9-17b are obtained from the .PLOT and .PROBE statements, respectively. The Probe plot required a little additional effort in responding to the menus at the bottom of the screen. The first column at the left-hand side of Fig. 9-17a gives the times at which the current is evaluated, and the second column gives the current values at these times. The values are plotted with the time axis being the vertical axis and the current axis the horizontal axis. The Probe plot of Fig. 9-17b is obviously superior in appearance, but it does not contain the current values explicitly at the various times as does the table with the other plot. But values can be obtained from the Probe plot by using the cursor feature which is included in the menus.



(a)

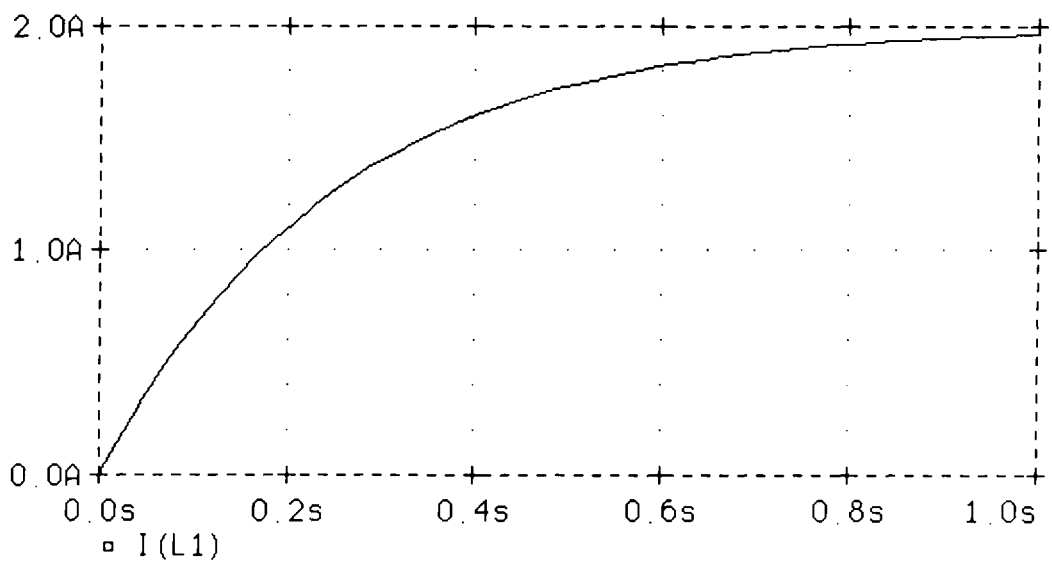

(b)

Fig. 9-17

- 9.30** In the circuit of Fig. 9-18, the switch is moved to position 1 at $t = 0$ s and then to position 2 at $t = 2$ s. The initial capacitor voltage is $v(0) = 20$ V. Find v for $t \geq 0$ s by hand and also by using PSpice.

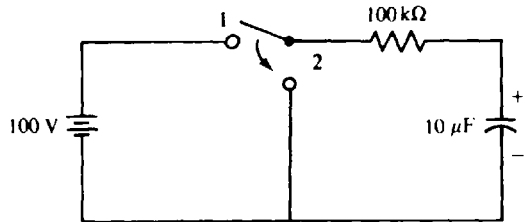

Fig. 9-18

The time constant is

$$\tau = RC = (100 \times 10^3)(10 \times 10^{-6}) = 1 \text{ s}$$

Also, $v(0) = 20$ V, and for the switch in position 1 the final voltage is $v(\infty) = 100$ V. Therefore,

$$v(t) = v(\infty) + [v(0) - v(\infty)]e^{-t/\tau} = 100 + (20 - 100)e^{-t} = 100 - 80e^{-t} \text{ V} \quad 0 \text{ s} \leq t \leq 2 \text{ s}$$

At $t = 2$ s,

$$v(2) = 100 - 80e^{-2} = 89.2 \text{ V}$$

So, for $t \geq 2$ s, $v(t) = 89.2e^{-(t-2)} = 658.9e^{-t}$ V.

For the PSpice circuit file, a suitable value for TSTOP is 5 s, which is three time constants after the second switching. This time is not critical, of course, and perhaps a preferable time would be 6 s, which is four time constants after the second switching. But 5 s will be used. The number of time steps is not critical either. For convenience, 20 will be used. Then,

$$\text{TSTEP} = \text{TSTOP}/20 = 5/20 = 0.25 \text{ s}$$

To obtain the effects of switching, a PULSE source will be used, with 0 V being one value and 100 V the other. The time duration of the 100 V is 2 s, of course. Alternatively, a PWL source could be used. A .PRINT statement will be included to generate a table of values, and a .PROBE statement to obtain a plot. Following is a suitable circuit file.

```
CIRCUIT FILE FOR THE CIRCUIT OF FIG. 9-18
V1 1 0 PULSE(0, 100, 0, 1U, 1U, 2)
R1 1 2 100K
C1 2 0 10U IC = 20
.TRAN 0.25 5 UIC
.PRINT TRAN V(C1)
.PROBE V(C1)
.END
```

If a PWL source were used instead of the PULSE source, the V1 statement would be

```
V1 1 0 PWL(0 0 1U 100 2 100 2.000001 0)
```

The V(C1) specification is included in the .PROBE statement so that Probe will store the V(2) node voltage under this name. Alternatively, this specification could be omitted and a trace of V(2) specified in the Probe mode.

When PSpice is run with this circuit file, the .PRINT statement generates the table of Fig. 9-19a, and the .PROBE statement generates Fig. 9-19b. Notice that the voltage value at $t = 2$ s is 89.2 V, which completely agrees with the value obtained by hand.

TIME	V(C1)
0.000E+00	2.000E+01
2.500E-01	3.766E+01
5.000E-01	5.144E+01
7.500E-01	6.221E+01
1.000E+00	7.057E+01
1.250E+00	7.709E+01
1.500E+00	8.216E+01
1.750E+00	8.611E+01
2.000E+00	8.920E+01
2.250E+00	6.951E+01
2.500E+00	5.413E+01
2.750E+00	4.213E+01
3.000E+00	3.282E+01
3.250E+00	2.554E+01
3.500E+00	1.989E+01
3.750E+00	1.548E+01
4.000E+00	1.206E+01
4.250E+00	9.386E+00
4.500E+00	7.310E+00
4.750E+00	5.689E+00
5.000E+00	4.429E+00

(a)

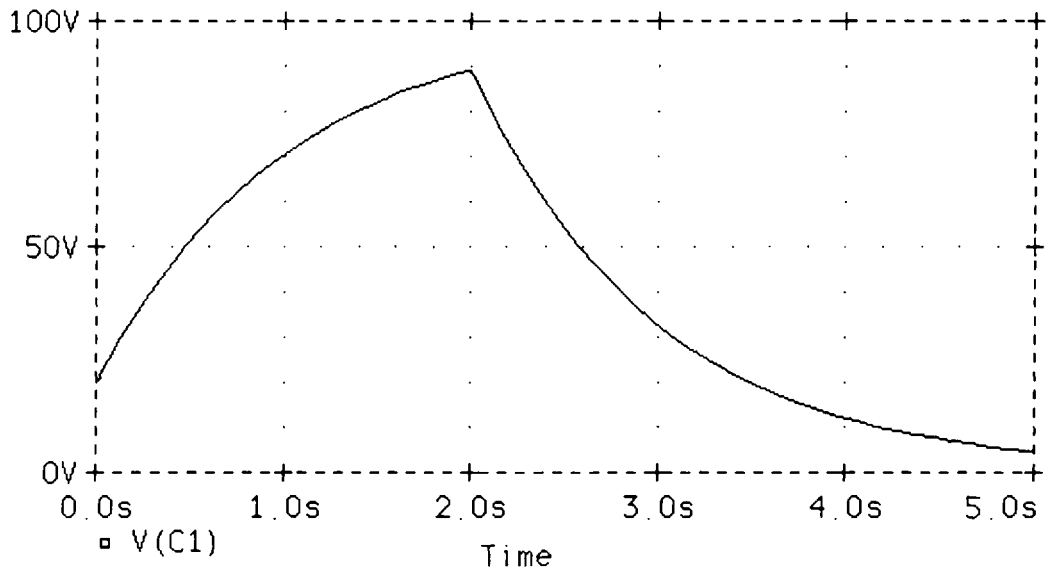

(b)

Fig. 9-19

Supplementary Problems

- 9.31** Find the voltage induced in a 500-turn coil when the flux changes uniformly by 16×10^{-5} Wb in 2 ms.
Ans. 40 V
- 9.32** Find the change in flux linking an 800-turn coil when 3.2 V is induced for 6 ms.
Ans. $24 \mu\text{Wb}$

- 9.33** What is the number of turns of a coil for which a flux change of 40×10^{-6} Wb in 0.4 ms induces 70 V in the coil?
Ans. 700 turns
- 9.34** Find the flux linking a 500-turn, 0.1-H coil carrying a 2-mA current.
Ans. $0.4 \mu\text{Wb}$
- 9.35** Find the approximate inductance of a single-layer, 300-turn air-core coil that is 3 in long and 0.25 in in diameter.
Ans. $47 \mu\text{H}$
- 9.36** Find the approximate inductance of a single-layer 500-turn coil that is wound on a ferromagnetic cylinder that is 1 in long and 0.1 in in diameter. The ferromagnetic material has a relative permeability of 8000.
Ans. 0.501 H
- 9.37** A 250-mH inductor has 500 turns. How many turns must be added to increase the inductance to 400 mH?
Ans. 132 turns
- 9.38** The current in a 300-mH inductor increases uniformly from 0.2 to 1 A in 0.5 s. What is the inductor voltage for this time?
Ans. 0.48 V
- 9.39** If a change in current in a 0.2-H inductor produces a constant 5-V inductor voltage, how long does the current take to increase from 30 to 200 mA?
Ans. 6.8 ms
- 9.40** What is the inductance of a coil for which a changing current increasing uniformly from 150 to 275 mA in $300 \mu\text{s}$ induces 75 mV in the coil?
Ans. $180 \mu\text{H}$
- 9.41** Find the voltage induced in a 200-mH coil from 0 to 5 ms when a current i described as follows flows through the coil: $i = 250t$ A for $0 \text{ s} \leq t \leq 1 \text{ ms}$, $i = 250$ mA for $1 \text{ ms} \leq t \leq 2 \text{ ms}$, and $i = 416 - 83\,000t$ mA for $2 \text{ ms} \leq t \leq 5 \text{ ms}$.
Ans. $v = 50 \text{ V}$ for $0 \text{ s} < t < 1 \text{ ms}$; 0 V for $1 \text{ ms} < t < 2 \text{ ms}$; -16.6 V for $2 \text{ ms} < t < 5 \text{ ms}$
- 9.42** Find the total inductance of four parallel inductors having inductances of 80, 125, 200, and 350 mH.
Ans. 35.3 mH
- 9.43** Find the total inductance of a 40-mH inductor in series with the parallel combination of a 60-mH inductor, an 80-mH inductor, and a 100-mH inductor.
Ans. 65.5 mH
- 9.44** A 2-H inductor, a 430- Ω resistor, and a 50-V source have been connected in series for a long time. What is the energy stored in the inductor?
Ans. 13.5 mJ
- 9.45** A current $i = 0.56t$ A flows through a 0.5-H inductor. Find the energy stored at $t = 6 \text{ s}$.
Ans. 2.82 J

9.46 What is the energy stored by the inductor in the circuit shown in Fig. 9.20 if $R = 20 \Omega$?

Ans. 667 mJ

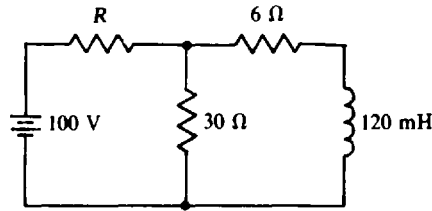

Fig. 9-20

9.47 Find the time constant of the circuit shown in Fig. 9-20 for $R = 90 \Omega$.

Ans. 4.21 ms

9.48 How long after a short circuit is placed across a coil carrying a current of 2 A does the current go to zero if the coil has 1.2 H of inductance and 40Ω of resistance? Also, how much energy is dissipated?

Ans. 0.15 s, 2.4 J

9.49 A switch closing connects in series a 10-V source, an $8.2\text{-}\Omega$ resistor, and a 1.2-H inductor. How long does the current take to reach its maximum value, and what is this value?

Ans. 732 ms, 1.22 A

9.50 In closing, a switch connects a 100-V source with 5Ω of internal resistance across the parallel combination of a $20\text{-}\Omega$ resistor and a 0.4-H inductor. What are the initial and final source currents, and what is the initial rate of inductor current increase?

Ans. 4 A, 20 A, 200 A/s

9.51 In the circuit shown in Fig. 9-21, the switch is thrown at $t = 0 \text{ s}$ from an open position to position 1. Find the indicated currents at $t = 0 + \text{s}$ and also at a long time later.

Ans. $i_1(0+) = 3.57 \text{ A}$, $i_2(0+) = 0 \text{ A}$, $i_1(\infty) = 2.7 \text{ A}$, $i_2(\infty) = 2.43 \text{ A}$

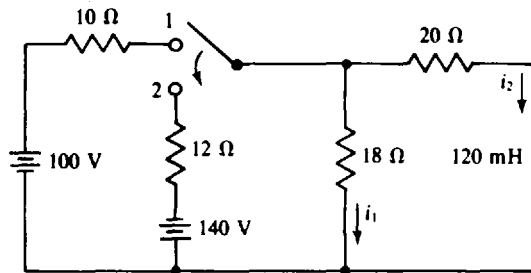

Fig. 9-21

9.52 In the circuit shown in Fig. 9-21, the switch is thrown at $t = 0 \text{ s}$ to position 2 from position 1 where it has been a long time. Find the indicated currents at $t = 0 + \text{s}$ and also at a long time later.

Ans. $i_1(0+) = -5.64 \text{ A}$, $i_2(0+) = 2.43 \text{ A}$, $i_1(\infty) = -3.43 \text{ A}$, $i_2(\infty) = -3.09 \text{ A}$

9.53 A switch closing at $t = 0 \text{ s}$ connects a 20-mH inductor to a 40-V source that has 10Ω of internal resistance. Find the inductor voltage and current for $t > 0 \text{ s}$.

Ans. $v = 40e^{-500t} \text{ V}$, $i = 4(1 - e^{-500t}) \text{ A}$

9.54 A switch closing at $t = 0$ s connects a 100-V source with a 15- Ω internal resistance to a coil that has 200 mH of inductance and 5 Ω of resistance. Find the coil voltage for $t > 0$ s.

Ans. $25 + 75e^{-100t}$ V

9.55 A coil for a relay has a resistance of 20 Ω and an inductance of 1.2 H. The relay requires 300 mA to operate. How soon will the relay operate after a 20-V source with 5 Ω of internal resistance is applied to the coil?

Ans. 22.6 ms

9.56 For the circuit shown in Fig. 9-22, find i as a function of time after the switch closes at $t = 0$ s.

Ans. $0.04(1 - e^{-500t})$ A

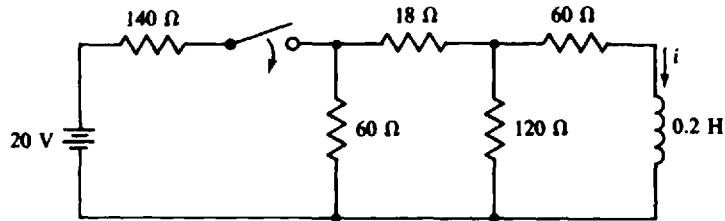

Fig. 9-22

9.57 Assume that the switch in the circuit shown in Fig. 9-22 has been closed a long time. Find i as a function of time after the switch opens at $t = 0$ s.

Ans. $0.04e^{-536t}$ A

9.58 In the circuit shown in Fig. 9-23, the switch is thrown to position 1 at $t = 0$ s after being open a long time. Then it is thrown to position 2 at $t = 2.5$ s. Find i for $t \geq 0$ s.

Ans. $50(1 - e^{-0.1t})$ A for $0 \leq t \leq 2.5$ s; $-20 + 31.1e^{-0.05(t-2.5)}$ A for $t \geq 2.5$ s

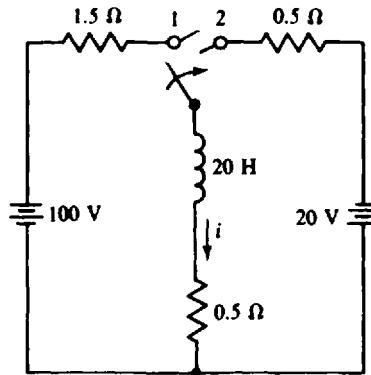

Fig. 9-23

9.59 Obtain the expression for the response for $t \geq 0$ s corresponding to the following circuit file. Also, from this expression, determine the 11th value that will be printed.

```

CIRCUIT FILE FOR PROB. 9.59
V1 1 0 120
R1 1 2 40K
C1 2 0 50U IC = 30
.TRAN 0.25 10 UIC
.PRINT TRAN V(C1)
.END
    
```

Ans. $120 - 90e^{-0.5t}$ V, 94.2 V

- 9.60** Obtain the expression for the response for $t \geq 0$ s corresponding to the following circuit file. Also, from this expression, determine the 9th value that will be printed.

```
CIRCUIT FILE FOR PROB. 9.60
V1 1 0 60
R1 1 2 20
L1 2 0 2 IC = -2
.TRAN 0.02 0.5 UIC
.PRINT TRAN I(R1)
.END
```

Ans. $3 - 5e^{-10t}$ A, 1.99 A

- 9.61** Obtain the expressions for the response for $t \geq 0$ s corresponding to the following circuit file. Also, from these expressions, determine the 17th value that will be printed.

```
CIRCUIT FILE FOR PROB. 9.61
V1 1 0 PULSE(0, 120, 0, 1U, 1U, 20M)
R1 1 2 300
R2 2 0 600
C1 2 0 50U IC = -50
.TRAN 2M 50M UIC
.PRINT TRAN V(C1)
.END
```

Ans. $80 - 130e^{-100t}$ V for $0 \leq t \leq 0.02$ s; $62.4e^{-100(t-0.02)}$ V for $t \geq 0.02$ s; 18.8 V

- 9.62** Obtain the expressions for the response for $t \geq 0$ s corresponding to the following circuit file. Also, from these expressions, determine the 13th value that will be printed.

```
CIRCUIT FILE FOR PROB. 9.62
I1 0 1 PWL(0 0 1U 0.1 0.032 0.1 0.032000001 0)
R1 1 0 300
R2 1 2 200
R3 2 0 500
L1 2 0 4 IC = -30M
.TRAN 0.004 0.08 UIC
.PRINT TRAN I(L1)
.END
```

Ans. $60 - 90e^{-62.5t}$ mA for $0 \leq t \leq 32$ ms; $47.8e^{-62.5(t-0.032)}$ mA for $t \geq 32$ ms; 17.6 mA

Sinusoidal Alternating Voltage and Current

INTRODUCTION

In the circuits considered so far, the independent sources have all been dc. From this point on, the circuits have *alternating-current (ac)* sources.

An ac voltage (or ac current) varies *sinusoidally* with time, as shown in Fig. 10-1a. This is a *periodic* voltage since it varies with time such that it continually repeats. The smallest nonrepeatable portion of a periodic waveform is a *cycle*, and the duration of a cycle is the *period* T of the wave. The reciprocal of the period, and the number of cycles in a period, is the *frequency*, which has a quantity symbol f :

$$f = \frac{1}{T}$$

The SI unit of frequency is the *hertz*, with unit symbol Hz.

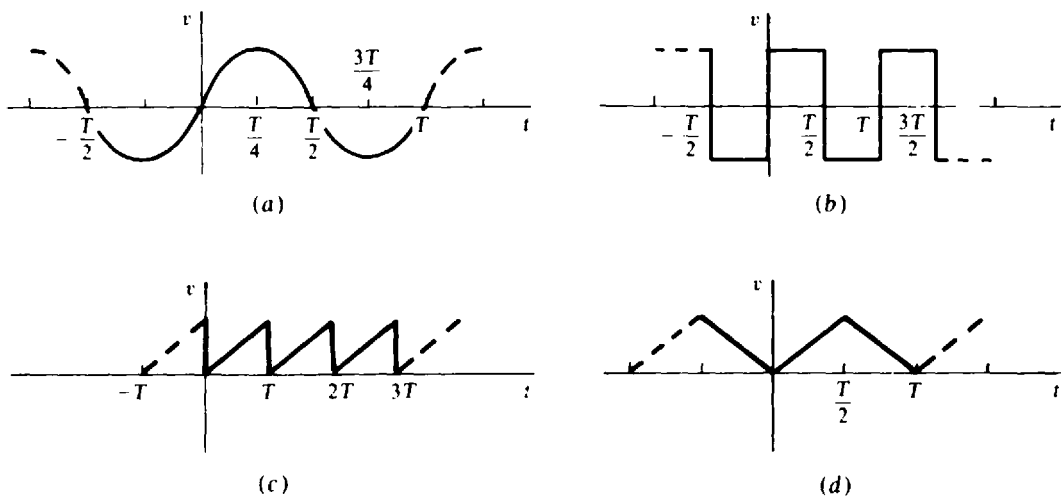

Fig. 10-1

In these definitions, notice the terms *wave* and *waveform*. They do not refer to the same thing. A wave is a varying voltage or current, but a waveform is a graph of such a voltage or current. Often, however, these terms are used interchangeably.

Although the *sine wave* of Fig. 10-1a is by far the most common periodic wave, there are other common ones: Figure 10-1b shows a square wave, Fig. 10-1c a sawtooth wave, and Fig. 10-1d a triangular wave. The dashed lines at both ends indicate that the waves have no beginnings and no ends, as is strictly required for periodic waves. But, of course, all practical voltages and currents have beginnings and ends. When a wave is obviously periodic, these dashed lines are often omitted.

The voltage waveforms shown in Fig. 10-1a and b are negative or below the time axis for part of each period. During these times, the corresponding voltages have polarities opposite the reference polarities. Of course, when the waveforms are above the time axis, these voltages have the same polarities as the references. For similar graphs of currents, the currents flow in the current reference directions when the waveforms are above the time axis, and in opposite directions when the waveforms are below that axis.

SINE AND COSINE WAVES

Figure 10-2 shows the basics of an ac generator or alternator for generating a sinusoidal voltage. The conductor, which in practice is a coil of wire, is rotated by a steam turbine or by some other source of mechanical energy. This rotation causes a continuous change of magnetic flux linking the conductor, thereby inducing a sine wave voltage in the conductor. This change of flux, and so the induced voltage, varies from zero when the conductor is horizontal to a maximum when the conductor is vertical. If $t = 0$ s corresponds to a time when the conductor is horizontal and the induced voltage is increasing, the induced voltage is $v = V_m \sin \omega t$, where V_m is the peak value or *amplitude*, \sin is the operation designator for a sine wave, ωt is the *argument*, and ω is the quantity symbol for the *radian frequency* of the voltage. (Some authors use the terms “angular velocity” or “angular frequency” instead of radian frequency.) The SI unit of radian frequency is *radian per second*, and the unit symbol is rad/s. The frequency f and the radian frequency ω are related by

$$\omega = 2\pi f$$

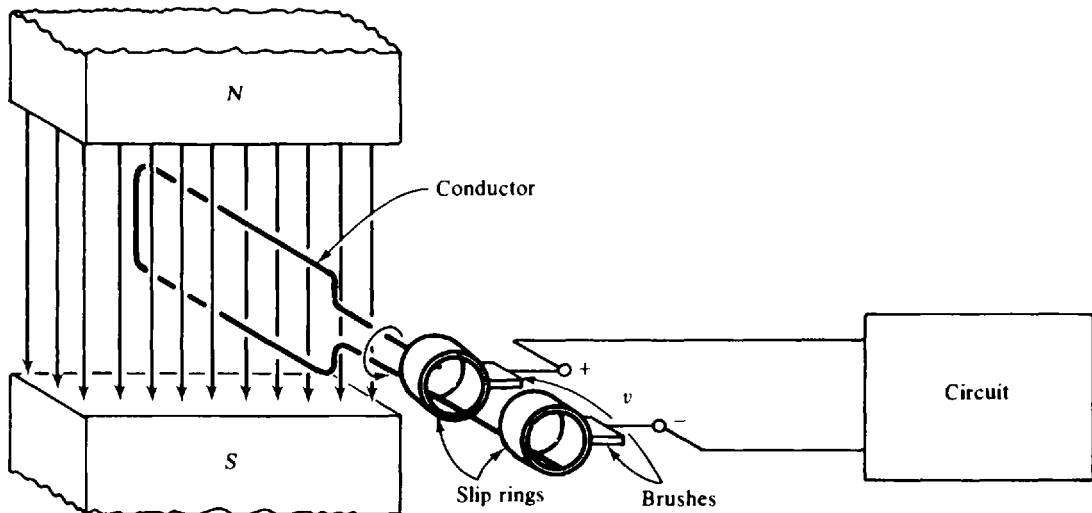

Fig. 10-2

The *radian* in radian per second is an SI angular unit, with symbol rad, and it is an alternative to degrees. A radian is the angle subtended by an arc on the circumference of a circle if the arc has a length equal to the radius. Since the circumference of a circle equals $2\pi r$, where r is the radius, it follows that 2π rad equals 360° or

$$1 \text{ rad} = \frac{360^\circ}{2\pi} = \frac{180^\circ}{\pi} = 57.3^\circ$$

This relation is useful for converting from degrees to radians and from radians to degrees. Specifically,

$$\text{Angle in radians} = \frac{\pi}{180^\circ} \times \text{angle in degrees}$$

and

$$\text{Angle in degrees} = \frac{180^\circ}{\pi} \times \text{angle in radians}$$

But, of course, a scientific calculator will perform either conversion at the press of a key. The waveform of $\sin \omega t$ has the shape shown in Fig. 10-1a. In each cycle it varies from 0 to a positive peak or maximum of 1, back to 0, then to a negative peak or minimum of -1 , and back to 0 again. For any value of the

argument ωt , $\sin \omega t$ can be evaluated with a calculator operated in the radians mode. Alternatively, the argument can be converted to degrees and the calculator operated in the more popular decimal degrees mode. For example, $\sin(\pi/6) = \sin 30^\circ = 0.5$.

The abscissa of a graph of a sine wave can be expressed in radians, degrees, or time. Sometimes, when time is used, it is in fractions of the period T , as in Fig. 10-1a. Usually, determining what the fractions should be is obvious from the corresponding proportions of a cycle.

Consider the graphing of one cycle of a specific ac voltage: $v_1 = 20 \sin 377t$ V. The peak value or amplitude is 20 V because $\sin 377t$ has a maximum value of 1. The radian frequency is $\omega = 377$ rad/s, which corresponds to $f = \omega/2\pi = 60$ Hz, the frequency of the electrical power systems in the United

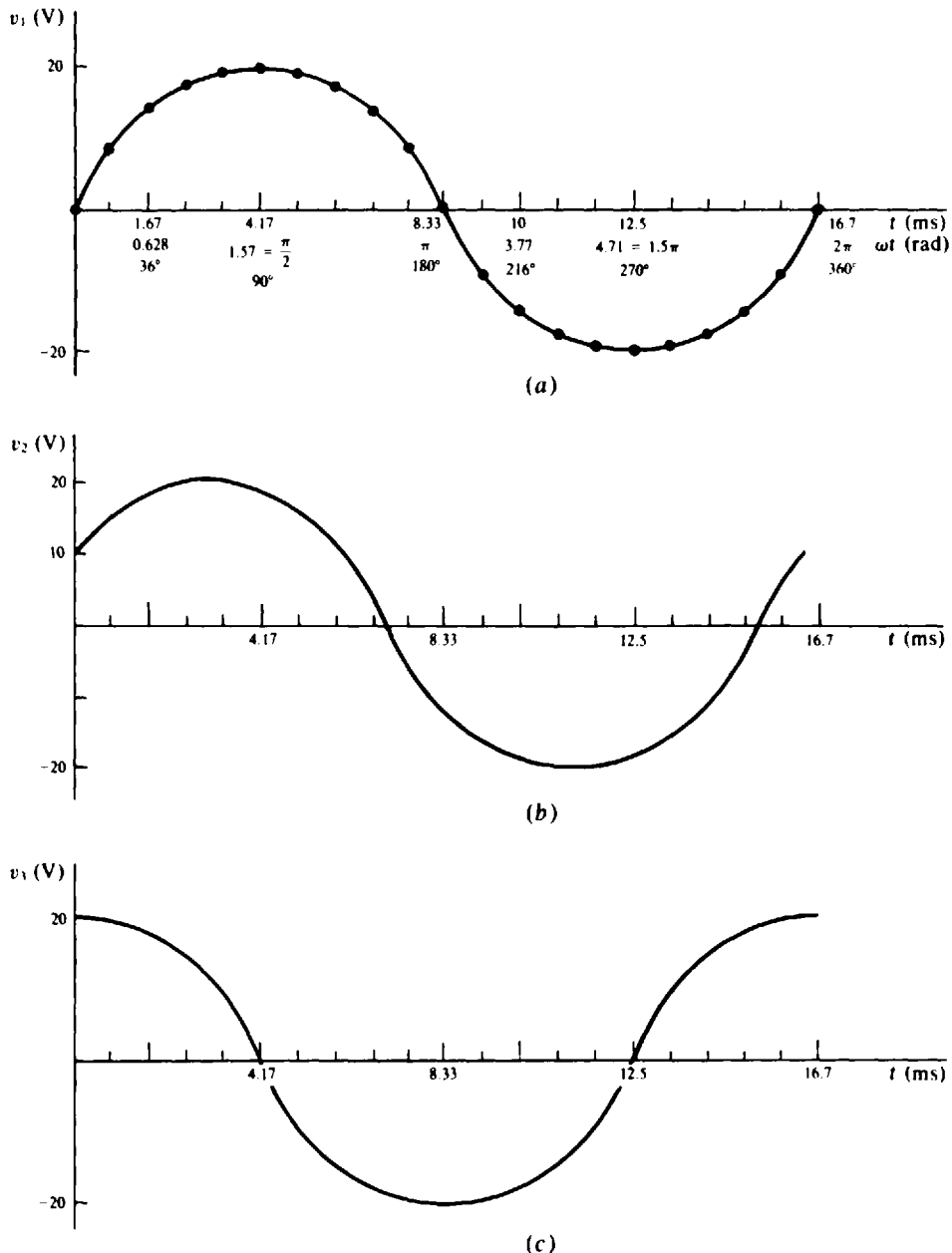

Fig. 10-3

States. The period is $T = 1/60 = 16.7$ ms. A cycle of this voltage can be plotted by substituting, into $20 \sin 377t$, different times for t from the time interval of $t = 0$ s to $t = 16.7$ ms. Figure 10-3a shows the results of evaluating this sine wave at 21 different times and drawing a smooth curve through the plotted points. For comparison purposes, all three abscissa units—seconds, radians, and degrees—are shown.

Figure 10-3b shows a graph of one cycle of $v_2 = 20 \sin(377t + 30^\circ)$ V. Notice that the argument $377t + 30^\circ$ is the sum of two terms, the first of which is in radians and the second of which is in degrees. Showing such an addition is common despite the fact that before the terms can be added, either the first term must be converted to degrees or the second term must be converted to radians. The 30° in the argument is called the *phase angle*.

The *cosine wave*, with designator *cos*, is as important as the sine wave. Its waveform has the same shape as the sine waveform, but is shifted 90° a fourth of a period ahead of it. Sine and cosine waves are so similar that the same term “sinusoid” is applied to both as well as to phase-shifted sine and cosine waves. Figure 10-3c is a graph of $v_3 = 20 \sin(377t + 90^\circ) = 20 \cos 377t$ V. Notice that the values of the cosine wave v_3 occur one-fourth period earlier than corresponding ones for the sine wave v_1 .

Some sine and cosine identities are important in the study of ac circuit analysis:

$$\begin{aligned} \sin(-x) &= -\sin x & \cos(-x) &= \cos x & \sin(x + 90^\circ) &= \cos x \\ \sin(x - 90^\circ) &= -\cos x & \cos(x + 90^\circ) &= -\sin x & \cos(x - 90^\circ) &= \sin x \\ \sin(x \pm 180^\circ) &= -\sin x & \cos(x \pm 180^\circ) &= -\cos x & \sin^2 x &= \frac{1 - \cos 2x}{2} \\ \cos^2 x &= \frac{1 + \cos 2x}{2} & \sin(x + y) &= \sin x \cos y + \sin y \cos x \\ \sin(x - y) &= \sin x \cos y - \sin y \cos x \\ \cos(x + y) &= \cos x \cos y - \sin x \sin y \\ \cos(x - y) &= \cos x \cos y + \sin x \sin y \\ \sin x &= \sin(x \pm N \times 360^\circ) & \text{and} & & \cos x &= \cos(x \pm N \times 360^\circ) & \text{for any integer } N \end{aligned}$$

PHASE RELATIONS

Sinusoids of the *same frequency* have *phase relations* that have to do with the angular difference of the sinusoidal arguments. For example, because of the added 30° in its argument, $v_2 = 20 \sin(377t + 30^\circ)$ V of the last section *leads* $v_1 = 20 \sin 377t$ V by 30° . Alternatively, v_1 *lags* v_2 by 30° . This means that the peaks, zeros, and other values of v_2 occur earlier than those of v_1 by a time corresponding to 30° . Another but less specific way of expressing this phase relation is to say that v_1 and v_2 have a 30° *phase difference* or that they are 30° *out of phase*. Similarly, the cosine wave v_3 leads the sine wave v_1 by 90° or v_1 lags v_3 by 90° . They have a phase difference of 90° ; they are 90° *out of phase*. Sinusoids that have a 0° phase difference are said to be *in phase*. Figure 10-4a shows sinusoids that are in phase, and Fig. 10-4b shows sinusoids that are 180° out of phase.

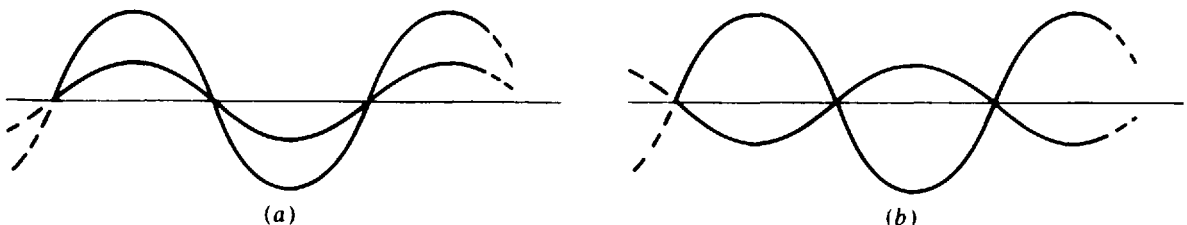

Fig. 10-4

The phase difference between two sinusoids can be found by subtracting the phase angle of one from that of the other, provided that both sinusoids have either the sine form or the cosine form, and that the amplitudes have the same sign—both positive or both negative. Additionally, of course, the two sinusoids must have the same frequency.

AVERAGE VALUE

The average value of a periodic wave is a quotient of area and time—the area being that between the corresponding waveform and the time axis for one period, and the time being one period. Areas above the time axis are positive, and areas below are negative. The areas must be algebraically added (signs must be included) to obtain the total area between the waveform and time axis for one period. (The average value of a periodic wave is always assumed to be calculated over a period unless otherwise specified.)

The average value of a sinusoid is zero because over one period the positive and negative areas cancel in the sum of the two areas. For some purposes, though, a nonzero “average” is used. By definition, it is the average of a positive half-cycle. From calculus, this average is $\frac{2}{\pi} = 0.637$ times the peak value.

RESISTOR SINUSOIDAL RESPONSE

If a resistor of R ohms has a voltage $v = V_m \sin(\omega t + \theta)$ across it, the current is, by Ohm's law, $i = v/R = (V_m/R) \sin(\omega t + \theta)$. The multiplier V_m/R is the current peak I_m : $I_m = V_m/R$. Notice that the current is in phase with the voltage. To repeat, *a resistor current and voltage are in phase.* (The references are, of course, assumed to be associated.)

Instantaneous resistor power dissipation varies with time because the instantaneous voltage and current vary with time, and the power is the product of the two. Specifically,

$$p = vi = [V_m \sin(\omega t + \theta)][I_m \sin(\omega t + \theta)] = V_m I_m \sin^2(\omega t + \theta)$$

which shows that the peak power is $P_m = V_m I_m$, and it occurs each time that $\sin(\omega t + \theta) = \pm 1$. From the identity $\sin^2 x = (1 - \cos 2x)/2$,

$$p = \frac{V_m I_m}{2} - \frac{V_m I_m}{2} \cos(2\omega t + 2\theta)$$

which is a constant plus a sinusoid of twice the frequency of the voltage and current. This instantaneous power is zero each time that the voltage and current are zero, but it is never negative because the positive first term is always equal to or greater than the second term, which is negative half the time. The fact that the power is never negative means that a resistor never delivers power to a circuit. Rather, it dissipates as heat all the energy it receives.

The average power supplied to a resistor is just the first term: $P_{av} = V_m I_m/2$, because the average value of the second term is zero. From $V_m = I_m R$,

$$P_{av} = \frac{V_m I_m}{2} = \frac{V_m^2}{2R} = \frac{I_m^2 R}{2}$$

These formulas differ from the corresponding dc formulas by a factor of $\frac{1}{2}$.

EFFECTIVE OR RMS VALUES

Although periodic voltages and currents vary with time, it is convenient to associate with them specific values called *effective values*. Effective voltages are used, for example, in the rating of electrical appliances. The 120-V rating of an electric hair dryer and the 240-V rating of an electric clothes dryer are effective values. Also, most ac ammeters and voltmeters give readings in effective values.

By definition, the effective value of a periodic voltage or current (V_{eff} or I_{eff}) is the *positive* dc voltage or current that produces the same average power loss in a resistor: $P_{\text{av}} = V_{\text{eff}}^2 R$ and $P_{\text{av}} = I_{\text{eff}}^2 R$. Since for a sinusoidal voltage the average power loss is $P_{\text{av}} = V_m^2 / 2R$,

$$P_{\text{av}} = \frac{V_{\text{eff}}^2}{R} = \frac{V_m^2}{2R} \quad \text{from which} \quad V_{\text{eff}} = \frac{V_m}{\sqrt{2}} = 0.707V_m$$

Similarly, $I_{\text{eff}} = I_m / \sqrt{2} = 0.707I_m$. So, *the effective value of a sinusoidal voltage or current equals the peak value divided by $\sqrt{2}$.*

Another name for effective value is *root mean square (rms)*. The corresponding voltage and current notations are V_{rms} and I_{rms} , which are the same as V_{eff} and I_{eff} . This name stems from a procedure for finding the effective or rms value of any periodic voltage or current— not just sinusoids. As can be derived using calculus, this procedure is to

1. *Square* the periodic voltage or current.
2. Find the average of this squared wave over one period. Another name for this average is the *mean*.
3. Find the positive square *root* of this average.

Unfortunately, except for square-type waves, finding the area in step 2 requires calculus. Incidentally, if this procedure is applied to a sawtooth and a triangular wave, the result is the same effective value— the peak value divided by $\sqrt{3}$.

INDUCTOR SINUSOIDAL RESPONSE

If an inductor of L henries has a current $i = I_m \sin(\omega t + \theta)$ flowing through it, the voltage across the inductor is

$$v = L \frac{di}{dt} = L \frac{d}{dt} [I_m \sin(\omega t + \theta)] = \omega L I_m \cos(\omega t + \theta)$$

The multiplier $\omega L I_m$ is the peak voltage V_m : $V_m = \omega L I_m$ and $I_m = V_m / \omega L$. From a comparison of $I_m = V_m / \omega L$ and $I_m = V_m / R$, clearly ωL has a current-limiting action similar to that of R .

The quantity ωL is called the *inductive reactance* of the inductor. Its quantity symbol is X_L :

$$X_L = \omega L$$

It has the same ohm unit as resistance. Unlike resistance, though, inductive reactance depends on frequency—the greater the frequency the greater its value and so the greater its current-limiting action. For sinusoids of very low frequency, approaching 0 Hz or dc, an inductive reactance is almost zero, which means that an inductor is almost a short circuit to such sinusoids, in agreement with dc results. At the other frequency extreme, for sinusoids of very high frequencies, approaching infinity, an inductive reactance approaches infinity, which means that an inductor is almost an open circuit to such sinusoids.

From a comparison of the inductor current and voltage sinusoids, it can be seen that *the inductor voltage leads the inductor current by 90° or the inductor current lags the inductor voltage by 90°.*

The instantaneous power absorbed by an inductor is

$$p = vi = [V_m \cos(\omega t + \theta)][I_m \sin(\omega t + \theta)] = V_m I_m \cos(\omega t + \theta) \sin(\omega t + \theta)$$

which from sine and cosine identities reduces to

$$p = \frac{V_m I_m}{2} \sin(2\omega t + 2\theta) = V_{\text{eff}} I_{\text{eff}} \sin(2\omega t + 2\theta)$$

This power is sinusoidal at twice the voltage and current frequency. Being sinusoidal, its average value is zero— *a sinusoidally excited inductor absorbs zero average power.* In terms of energy, at the times

when p is positive, an inductor absorbs energy. And at the times when p is negative, an inductor returns energy to the circuit and acts as a source. Over a period, it delivers just as much energy as it receives.

CAPACITOR SINUSOIDAL RESPONSE

If a capacitor of C farads has a voltage $v = V_m \sin(\omega t + \theta)$ across it, the capacitor current is

$$i = C \frac{dv}{dt} = C \frac{d}{dt} [V_m \sin(\omega t + \theta)] = \omega C V_m \cos(\omega t + \theta)$$

The multiplier $\omega C V_m$ is the peak current I_m : $I_m = \omega C V_m$ and $V_m I_m = 1/\omega C$. So, a capacitor has a current-limiting action similar to that of a resistor, with $1/\omega C$ corresponding to R . Because of this, some electric circuits books define *capacitive reactance* as $1/\omega C$. However, almost all electrical engineering circuits books include a negative sign and define capacitive reactance as

$$X_C = -\frac{1}{\omega C}$$

The negative sign relates to phase shift, as will be explained in Chap. 12. Of course, the quantity symbol for capacitive reactance is X_C and the unit is the ohm.

Because $1/\omega C$ is inversely proportional to frequency, the greater the frequency the greater the current for the same voltage peak. For high-frequency sinusoids, a capacitor is almost a short circuit, and for low-frequency sinusoids approaching 0 Hz or dc, a capacitor is almost an open circuit.

From a comparison of the capacitor voltage and current sinusoids, it can be seen that *the capacitor current leads the capacitor voltage by 90°, or the capacitor voltage lags the capacitor current by 90°*. This is the opposite of the inductor voltage and current phase relation.

The instantaneous power absorbed by a capacitor is

$$p = vi = [V_m \sin(\omega t + \theta)][I_m \cos(\omega t + \theta)] = \frac{V_m I_m}{2} \sin(2\omega t + 2\theta)$$

the same as for an inductor. The instantaneous power absorbed is sinusoidal at twice the voltage and current frequency and has a zero average value. So, *a capacitor absorbs zero average power*. Over a period a capacitor delivers just as much energy as it absorbs.

Solved Problems

10.1 Find the periods of periodic voltages that have frequencies of (a) 0.2 Hz, (b) 12 kHz, and (c) 4.2 MHz.

(a) From $T = 1/f$, $T = 1/0.2 = 5$ s

(b) Similarly, $T = 1/(12 \times 10^3) \text{ s} = 83.3 \mu\text{s}$

(c) $T = 1/(4.2 \times 10^6) \text{ s} = 238$ ns

10.2 Find the frequencies of periodic currents that have periods of (a) 50 μs , (b) 42 ms, and (c) 1 h.

(a) From $f = 1/T$, $f = 1/(50 \times 10^{-6}) \text{ Hz} = 20$ kHz

(b) Similarly, $f = 1/(42 \times 10^{-3}) = 23.8$ Hz

(c) $f = \frac{1}{1 \text{ h}} \times \frac{1 \text{ h}}{3600 \text{ s}} = 2.78 \times 10^{-4} \text{ Hz} = 0.278$ mHz

10.3 What are the period and frequency of a periodic voltage that has 12 cycles in 46 ms?

The period is the time taken for one cycle, which can be found by dividing the 12 cycles into the time that it takes for them to occur (46 ms): $T = 46/12 = 3.83$ ms. Of course, the frequency is the reciprocal of the period: $f = 1/(3.83 \times 10^{-3}) = 261$ Hz. Alternatively, but what amounts to the same thing, the frequency is the number of cycles that occur in 1 s: $f = 12/(46 \times 10^{-3}) = 261$ Hz.

10.4 Find the period, the frequency, and the number of cycles shown for the periodic wave illustrated in Fig. 10-5.

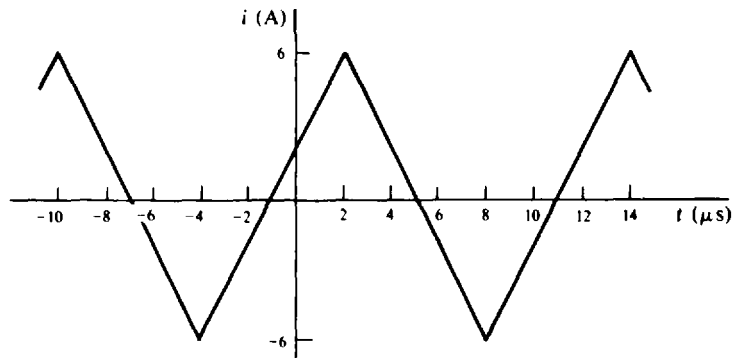

Fig. 10-5

The wave has one positive peak at $2 \mu\text{s}$ and another positive peak at $14 \mu\text{s}$, between which times there is one cycle. So, the period is $T = 14 - 2 = 12 \mu\text{s}$, and the frequency is $f = 1/T = 1/(12 \times 10^{-6}) \text{ Hz} = 83.3 \text{ kHz}$. There is one other cycle shown— from -10 to $2 \mu\text{s}$.

10.5 Convert the following angles in degrees to angles in radians: (a) 49° , (b) -130° , and (c) 435° .

$$(a) \quad 49^\circ \times \frac{\pi}{180} = 0.855 \text{ rad}$$

$$(b) \quad -130^\circ \times \frac{\pi}{180} = -2.27 \text{ rad}$$

$$(c) \quad 435^\circ \times \frac{\pi}{180} = 7.59 \text{ rad}$$

10.6 Convert the following angles in radians to angles in degrees: (a) $\pi/18$ rad, (b) -0.562 rad, and (c) 4 rad.

$$(a) \quad \frac{\pi}{18} \times \frac{180}{\pi} = 10$$

$$(b) \quad -0.562 \times \frac{180}{\pi} = -32.2$$

$$(c) \quad 4 \times \frac{180}{\pi} = 229$$

- 10.7** Find the periods and frequencies of sinusoidal currents that have radian frequencies of (a) 9π rad/s, (b) 0.042 rad/s, and (c) 13 Mrad/s.

From $f = \omega/2\pi$ and $T = 1/f$,

(a) $f = 9\pi/2\pi = 4.5$ Hz, $T = 1/4.5 = 0.222$ s

(b) $f = 0.042/2\pi$ Hz = 6.68 mHz, $T = 1/(6.68 \times 10^{-3}) = 150$ s

(c) $f = 13 \times 10^6/2\pi$ Hz = 2.07 MHz, $T = 1/(2.07 \times 10^6)$ s = 0.483 μ s

- 10.8** Find the radian frequencies of sinusoidal voltages that have periods of (a) 4 s, (b) 6.3 ms, and (c) 7.9 μ s.

From $\omega = 2\pi f = 2\pi/T$,

(a) $\omega = 2\pi/4 = 1.57$ rad/s

(b) $\omega = 2\pi/(6.3 \times 10^{-3}) = 997$ rad/s

(c) $\omega = 2\pi/(7.9 \times 10^{-6})$ rad/s = 0.795 Mrad/s

- 10.9** Find the amplitudes and frequencies of (a) $42.1 \sin(377t + 30^\circ)$ and (b) $-6.39 \cos(10^5t - 20^\circ)$.

(a) The amplitude is the *magnitude* of the multiplier: $|42.1| = 42.1$. Note the vertical lines about 42.1 for designating the magnitude operation, which removes a negative sign, if there is one. The radian frequency is the multiplier of t : 377 rad/s. From it, and $f = \omega/2\pi$, the frequency is $f = 377/2\pi = 60$ Hz.

(b) Similarly, the amplitude is $|-6.39| = 6.39$. The radian frequency is 10^5 rad/s, from which $f = \omega/2\pi = 10^5/2\pi$ Hz = 15.9 kHz.

- 10.10** Find the instantaneous value of $v = 70 \sin 400\pi t$ V at $t = 3$ ms.

Substituting for t : $v(3 \text{ ms}) = 70 \sin(400\pi \times 3 \times 10^{-3}) = 70 \sin 1.2\pi$ V. Since the 1.2π sinusoidal argument is in radians, a calculator must be operated in the radians mode for this evaluation. The result is -41.1 V. Alternatively, the angle can be converted to degrees: $1.2\pi \times 180/\pi = 216^\circ$, and a calculator operated in the more popular decimal degrees mode: $v(3 \text{ ms}) = 70 \sin 216^\circ = -41.1$ V.

- 10.11** A current sine wave has a peak of 58 mA and a radian frequency of 90 rad/s. Find the instantaneous current at $t = 23$ ms.

From the specified peak current and frequency, the expression for the current is $i = 58 \sin 90t$ mA. For $t = 23$ ms, this evaluates to

$$i(23 \text{ ms}) = 58 \sin(90 \times 23 \times 10^{-3}) = 58 \sin 2.07 = 50.9 \text{ mA}$$

Of course, the 2.07 in radians could have been converted to degrees: $2.07 \times 180/\pi = 118.6^\circ$, and then $58 \sin 118.6^\circ$ evaluated.

- 10.12** Evaluate (a) $v = 200 \sin(3393t + \pi/7)$ V and (b) $i = 67 \cos(3016t - 42^\circ)$ mA at $t = 1.1$ ms.

From substituting 1.1×10^{-3} for t ,

(a) $v(1.1 \text{ ms}) = 200 \sin(3393 \times 1.1 \times 10^{-3} + \pi/7) = 200 \sin 4.18 = -172$ V

Operating a calculator in the radians mode is convenient for this calculation because both parts of the sinusoidal argument are in radians.

(b) $i(1.1 \text{ ms}) = 67 \cos(3016 \times 1.1 \times 10^{-3} - 42^\circ) = 67 \cos(190^\circ - 42^\circ) = -56.9$ mA

Note that the first term was converted from radians to degrees so that it could be added to the second term. Alternatively, the second term could have been converted to radians.

- 10.13** Find expressions for the sinusoids shown in Fig. 10-6.

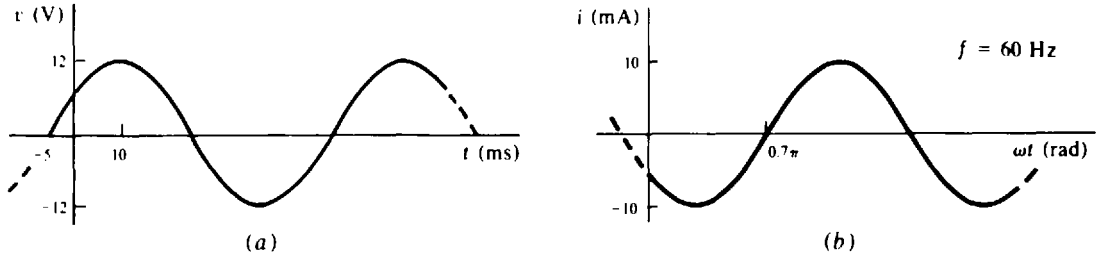

Fig. 10-6

The sinusoid shown in Fig. 10-6a can be considered to be either a phase-shifted sine wave or a phase-shifted cosine wave—it does not make any difference. For the selection of a phase-shifted sine wave, the general expression is $v = 12 \sin(\omega t + \theta)$, since the peak value is shown as 12. The radian frequency ω can be found from the period. One-fourth of a period occurs in the 15-ms time interval from -5 to 10 ms, which means that $T = 4 \times 15 = 60$ ms, and so $\omega = 2\pi/T = 2\pi/(60 \times 10^{-3}) = 104.7$ rad/s. From the zero value at $t = -5$ ms and the fact that the waveform is going from negative to positive then, just as a sine wave does for a zero argument, the argument can be zero at this time: $104.7(-5 \times 10^{-3}) + \theta = 0$, from which $\theta = 0.524$ rad $\approx 30^\circ$. The result is $v = 12 \sin(104.7t + 0.524) = 12 \sin(104.7t + 30^\circ)$ V.

Now consider the equation for the current shown in Fig. 10-6b. From $\omega = 2\pi f = 2\pi(60) = 377$ rad/s and the peak value of 10 mA, $i = 10 \cos(377t + \theta)$ mA, with the arbitrary selection of a phase-shifted cosine wave. The angle θ can be determined from the zero value at $\omega t = 0.7\pi$. For this value of ωt , the phase-shifted cosine argument can be 1.5π rad because at 1.5π rad $= 270^\circ$ a cosine waveform is zero and going from negative to positive, as can be seen from Fig. 10-3c. So, for $\omega t = 0.7\pi$, the argument can be $\omega t + \theta = 0.7\pi + \theta = 1.5\pi$, from which $\theta = 0.8\pi$ rad $= 144^\circ$. The result is $i = 10 \cos(377t + 0.8\pi) = 10 \cos(377t + 144^\circ)$ mA.

10.14 Sketch a cycle of $v = 30 \sin(754t + 60^\circ)$ V for the period beginning at $t = 0$ s. Have all three abscissa units of time, radians, and degrees.

A fairly accurate sketch can be made from the initial value, the peaks of 30 and -30 V, and the times at which the waveform is zero and at its peaks. Also needed is the period, which is $T = 2\pi/\omega = 2\pi/754 = 8.33$ ms. The initial value can be found by substituting 0 for t in the argument. The result is $v = 30 \sin 60^\circ = 26$ V. The waveform is zero for the first time when the argument is π radians since $\sin \pi = 0$. This time can be found from the argument with the 60° converted to $\pi/3$ radians: $754t + \pi/3 = \pi$, from which $t = 2.78$ ms. The next zero is half a period later: $2.78 + 8.33/2 = 6.94$ ms. The positive peak for this cycle occurs at a time when the sinusoidal argument is $\pi/2$: $754t + \pi/3 = \pi/2$, from which $t = 0.694$ ms. The negative peak is half a period later: $t = 0.694 + 8.33/2 = 4.86$ ms. The radian units for these times can be found from $\omega t = 754t = 240\pi t$. Of course, the corresponding degree units can be found by converting from radians to degrees. Figure 10-7 shows the sinusoid.

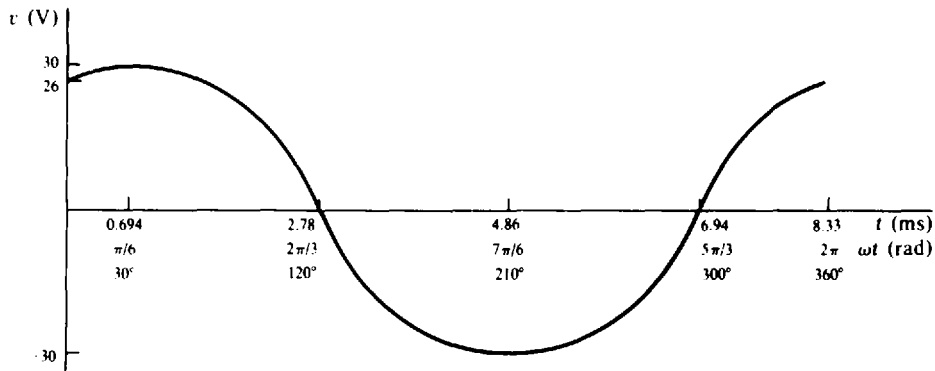

Fig. 10-7

- 10.15** What is the shortest time required for a 2.1 krad/s sinusoid to increase from zero to four-fifths of its peak value?

For convenience, the expression for the sinusoid can be considered to be $V_m \sin(2.1 \times 10^3 t)$. The time required for this wave to equal $0.8 V_m$ can be found from $V_m \sin(2.1 \times 10^3 t) = 0.8 V_m$, which simplifies to $\sin(2.1 \times 10^3 t) = 0.8$. This can be evaluated for t by taking the inverse sine, called the *arcsine*, of both sides. This operation causes the sin operation to be canceled, leaving the argument. On a calculator, the arcsine may be designated by “sin⁻¹” or “asin.” Taking the arcsine of both sides produces

$$\sin^{-1}[\sin(2.1 \times 10^3 t)] = \sin^{-1} 0.8$$

which simplifies to $2.1 \times 10^3 t = \sin^{-1} 0.8$, from which

$$t = \frac{\sin^{-1} 0.8}{2.1 \times 10^3} = \frac{0.9273}{2.1 \times 10^3} \text{ s} = 0.442 \text{ ms}$$

The 0.9273 is, of course, in radians.

- 10.16** If 50 V is the peak voltage induced in the conductor of the alternator shown in Fig. 10-2, find the voltage induced after the conductor has rotated through an angle of 35° from its vertical position.

When the conductor is in a vertical position, the induced voltage is a maximum in magnitude, but can be either positive or negative. The vertical position can, for convenience, be considered to correspond to 0°. Then, since the induced voltage is sinusoidal, and since the cosine wave has a peak at 0°, the voltage can be considered to be $v = \pm 50 \cos \theta$, in which θ is the angle of the conductor from the vertical. So, with the conductor at 35° from the vertical, the induced voltage is $v = +50 \cos 35^\circ = \pm 41 \text{ V}$.

- 10.17** If the conductor in the alternator shown in Fig. 10-2 is rotating at 60 Hz, and if the induced voltage has a peak of 20 V, find the induced voltage 20 ms after the conductor passes through a horizontal position if the voltage is increasing then.

The simplest expression for the induced voltage is $v = 20 \sin 377t \text{ V}$ if $t = 0 \text{ s}$ corresponds to the time at which the conductor is in the specified horizontal position. This is the voltage expression because the induced voltage is sinusoidal, 20 V is specified as the peak, 377 rad/s corresponds to 60 Hz, and $\sin \omega t$ is zero at $t = 0 \text{ s}$ and is increasing. So,

$$v(20 \times 10^{-3}) = 20 \sin(377 \times 20 \times 10^{-3}) = 20 \sin 7.54 = 20 \sin 43.2^\circ = 19 \text{ V}$$

- 10.18** Find the periods of (a) $7 - 4 \cos(400t + 30^\circ)$, (b) $3 \sin^2 4t$, and (c) $4 \cos 3t \sin 3t$.

(a) The expression $7 - 4 \cos(400t + 30^\circ)$ is a sinusoid of $-4 \cos(400t + 30^\circ)$ “riding” on a constant 7. Since only the sinusoid contributes to the variations of the wave, only it determines the period: $T = 2\pi/\omega = 2\pi/400 \text{ s} = 15.7 \text{ ms}$.

(b) Because of the square, it is not immediately obvious what the period is. The identity $\sin^2 x = (1 - \cos 2x)/2$ can be used to eliminate the square:

$$3 \sin^2 4t = 3 \left[\frac{1 - \cos(2 \times 4t)}{2} \right] = 1.5(1 - \cos 8t)$$

From the cosine wave portion, the period is $T = 2\pi/\omega = 2\pi/8 = 0.785 \text{ s}$.

(c) Because of the product of the sinusoids in $4 \cos 3t \sin 3t$, some simplification must be done before the period can be determined. The identity $\sin(x + y) = \sin x \cos y + \sin y \cos x$ can be used for this by setting $y = x$. The result is

$$\sin(x + x) = \sin x \cos x + \sin x \cos x \quad \text{or} \quad \sin 2x = 2 \sin x \cos x$$

from which $\sin x \cos x = (\sin 2x)/2$. Here, $x = 3t$, and so

$$4 \cos 3t \sin 3t = 4 \left[\frac{\sin (2 \times 3t)}{2} \right] = 2 \sin 6t$$

From this, the period is $T = 2\pi/\omega = 2\pi/6 = 1.05$ s.

10.19 Find the phase relations for the following pairs of sinusoids:

- (a) $v = 60 \sin (377t + 50^\circ)$ V, $i = 3 \sin (754t - 10^\circ)$ A
- (b) $v_1 = 6.4 \sin (7.1\pi t + 30^\circ)$ V, $v_2 = 7.3 \sin (7.1\pi t - 10^\circ)$ V
- (c) $v = 42.3 \sin (400t + 60^\circ)$ V, $i = -4.1 \sin (400t - 50^\circ)$ A

- (a) There is no phase relation because the sinusoids have different frequencies.
- (b) The angle by which v_1 leads v_2 is the phase angle of v_1 minus the phase angle of v_2 : $\text{ang } v_1 - \text{ang } v_2 = 30^\circ - (-10^\circ) = 40^\circ$. Alternatively, v_2 lags v_1 by 40° .
- (c) The amplitudes must have the same sign before a phase comparison can be made. The negative sign of i can be eliminated by using the identity $-\sin x = \sin (x \pm 180^\circ)$. The positive sign in \pm is more convenient because, as will be seen, it leads to a phase difference of the smallest angle, as is generally preferable. The result is

$$i = -4.1 \sin (400t - 50^\circ) = 4.1 \sin (400t - 50^\circ + 180^\circ) = 4.1 \sin (400t + 130^\circ) \text{ A}$$

The angle by which v leads i is the phase angle of v minus the phase angle of i : $\text{ang } v - \text{ang } i = 60^\circ - 130^\circ = -70^\circ$. The negative sign indicates that v lags, instead of leads, i by 70° . Alternatively, i leads v by 70° . If the negative sign in \pm had been used, the result would have been that v leads i by 290° , which is equivalent to -70° because 360° can be subtracted from (or added to) a sinusoidal angle without affecting the value of the sinusoid.

10.20 Find the angle by which $i_1 = 3.1 \sin (754t - 20^\circ)$ mA leads $i_2 = -2.4 \cos (754t + 30^\circ)$ mA.

Before a phase comparison can be made, both amplitudes must have the same sign, and both sinusoids must be of the same form: either phase-shifted sine waves or phase shifted cosine waves. The negative sign of i_2 can be eliminated by using the identity $-\cos x = \cos (x \pm 180^\circ)$. At this point it is not clear whether the positive or negative sign is preferable, and so both will be kept:

$$i_2 = 2.4 \cos (754t + 210^\circ) = 2.4 \cos (754t - 150^\circ) \text{ mA}$$

Both of these phase-shifted cosine waves can be converted to phase-shifted sine waves by using the identity $\cos x = \sin (x + 90^\circ)$:

$$i_2 = 2.4 \sin (754t + 300^\circ) = 2.4 \sin (754t - 60^\circ) \text{ mA}$$

Now a phase angle comparison can be made: i_1 leads i_2 by $-20^\circ - 300^\circ = -320^\circ$ from the first i_2 expression, or by $-20^\circ - (-60^\circ) = 40^\circ$ from the second i_2 expression. Being smaller in magnitude, the 40° lead is preferable to a -320° lead. But both are equivalent.

10.21 Find the average values of the periodic waveforms shown in Fig. 10-8.

The waveform shown in Fig. 10-8a is a sinusoid “riding” on top of a constant 3 V. Since the average value of the sinusoid is zero, the average value of the waveform equals the constant 3 V.

The average value of the waveform shown in Fig. 10-8b, and of any waveform, is the area under the waveform for one period, divided by the period. Since for the cycle beginning at $t = 0$ s, the waveform is at 8 V for half a period and is at 1 V for the other half-period, the area underneath the curve for this one cycle is, from the height-times-base formula for a rectangular area, $8 \times T/2 + 1 \times T/2 = 4.5T$. So, the average value is $4.5T/T = 4.5$ V. Note that the average value does not depend on the period. This is generally true.

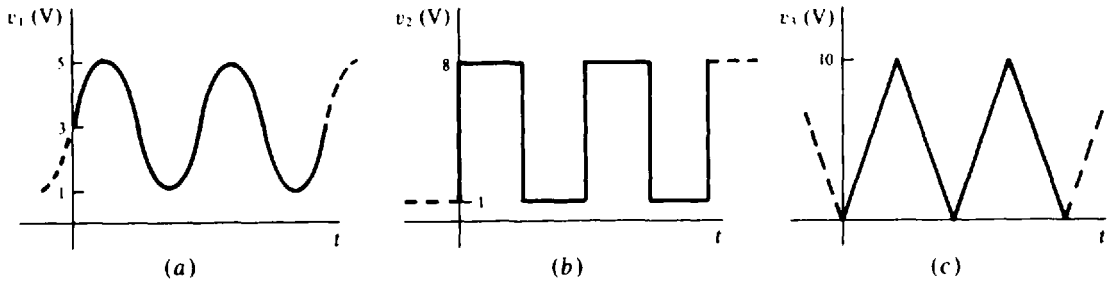

Fig. 10-8

The cycle of the waveform shown in Fig. 10-8c beginning at $t = 0$ s is a triangle with a height of 10 and a base of T . The area under the curve for this one cycle is, from the triangular area formula of one-half the height times the base, $0.5 \times 10 \times T = 5T$. And so the average value is $5T/T = 5$ V.

10.22 What are the average values of the periodic waveforms shown in Fig. 10-9?

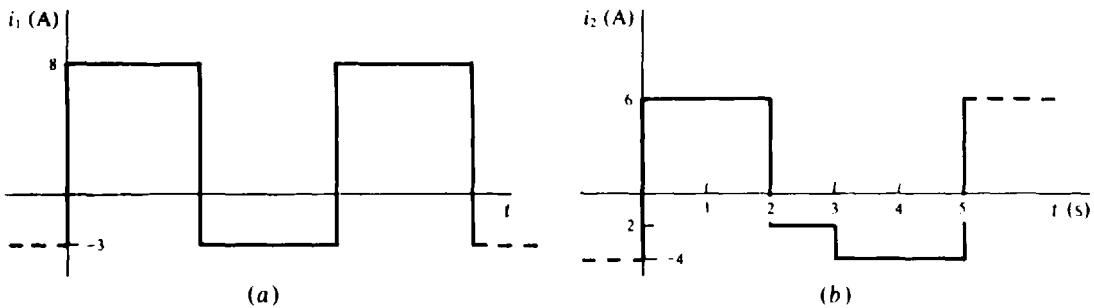

Fig. 10-9

For the cycle starting at $t = 0$ s, the i_1 waveform shown in Fig. 10-9a is at 8 A for half a period and is at -3 A for the next half-period. So, the area for this cycle is $8(T/2) + (-3)(T/2) = 2.5T$, and the average value is $2.5T/T = 2.5$ A.

The i_2 waveform shown in Fig. 10-9b has a complete cycle from $t = 0$ s to $t = 5$ s. For the first 2 s the area under the curve is $6 \times 2 = 12$. For the next second it is $-2 \times 1 = -2$. And for the last 2 s it is $-4 \times 2 = -8$. The algebraic sum of these areas is $12 - 2 - 8 = 2$, which divided by the period of 5 results in an average value of $2/5 = 0.4$ A.

10.23 What is the average power absorbed by a circuit component that has a voltage $v = 6 \sin(377t + 10^\circ)$ V across it when a current $i = 0.3 \sin(377t - 20^\circ)$ A flows through it? Assume associated references since there is no statement to the contrary.

The average power is, of course, the average value of the instantaneous power p :

$$p = vi = [6 \sin(377t + 10^\circ)][0.3 \sin(377t - 20^\circ)] = 1.8 \sin(377t + 10^\circ) \sin(377t - 20^\circ) \text{ W}$$

This can be simplified using a sine-cosine identity derived by subtracting $\cos(x + y) = \cos x \cos y - \sin x \sin y$ from $\cos(x - y) = \cos x \cos y + \sin x \sin y$. The result is the identity $\sin x \sin y = 0.5[\cos(x - y) - \cos(x + y)]$. Here, $x = 377t + 10^\circ$ and $y = 377t - 20^\circ$. So,

$$\begin{aligned} p &= 0.5[1.8 \cos(377t + 10^\circ - 377t + 20^\circ) - 1.8 \cos(377t + 10^\circ + 377t - 20^\circ)] \\ &= 0.9 \cos 30^\circ - 0.9 \cos(754t - 10^\circ) \text{ W} \end{aligned}$$

Since the second term is a sinusoid, and so has an average value of zero, the average power equals the first term:

$$P_{av} = 0.9 \cos 30^\circ = 0.779 \text{ W}$$

Note in particular that the average power is *not* equal to the product of the average voltage (0 V) and the average current (0 A), nor is it equal to the product of the effective value of voltage ($6/\sqrt{2}$) and the effective value of current ($0.3/\sqrt{2}$).

10.24 If the voltage across a single circuit component is $v = 40 \sin(400t + 10^\circ)$ V for a current through it of $i = 34.1 \sin(400t + 10^\circ)$ mA, and if the references are associated, as should be assumed, what is the component?

Since the voltage and current are in phase, the component is a resistor. The resistance is $R = V_m/I_m = 40/(34.1 \times 10^{-3}) \Omega = 1.17 \text{ k}\Omega$.

10.25 The voltage across a 62- Ω resistor is $v = 30 \sin(200\pi t + 30^\circ)$ V. Find the resistor current and plot one cycle of the voltage and current waveforms on the same graph.

From $i = v/R$, $i = [30 \sin(200\pi t + 30^\circ)]/62 = 0.484 \sin(200\pi t + 30^\circ)$ A. Of course, the period is $T = 2\pi/\omega = 2\pi/200\pi \text{ s} = 10 \text{ ms}$. For both waves, the curves will be plotted from the initial, peak, and zero values and the times at which they occur. At $t = 0 \text{ s}$, $v = 30 \sin 30^\circ = 15 \text{ V}$ and $i = 0.484 \sin 30^\circ = 0.242 \text{ A}$. The positive peaks of 30 V and 0.484 A occur at a time t_p corresponding to 60° since the sinusoidal arguments are 90° then. From the proportionality $t_p/T = 60^\circ/360^\circ$, the peak time is $t_p = 10/6 = 1.67 \text{ ms}$. Of course, the negative peaks occur at a half-period later, at $1.67 + 5 = 6.67 \text{ ms}$. The first zero values occur at a time corresponding to 150° because the sinusoidal arguments are 180° then. Using a proportionality again, this time is $(150/360)(10) = 4.17 \text{ ms}$. The next zeros occur one half-period later, at $4.17 + 5 = 9.17 \text{ ms}$. The voltage and current waveforms are shown in Fig. 10-10. The relative heights of the voltage and current peaks should not be of concern, because they are in different units.

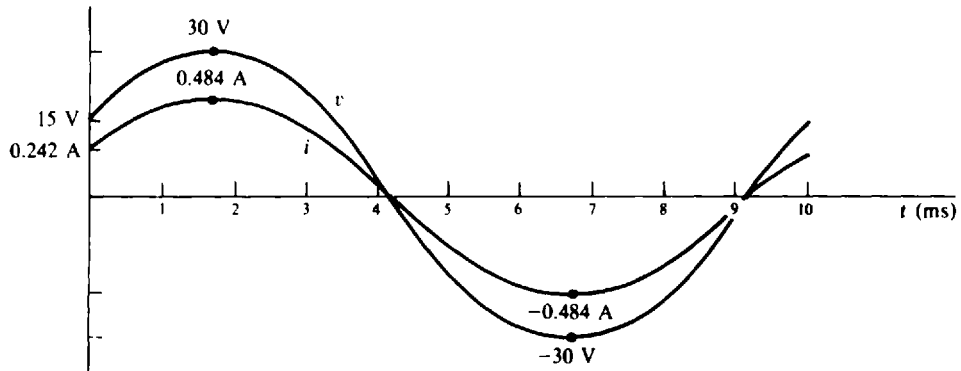

Fig. 10-10

10.26 A 30- Ω resistor has a voltage of $v = 170 \sin(377t + 30^\circ)$ V across it. What is the average power dissipation of the resistor?

$$P_{av} = \frac{V_m^2}{2R} = \frac{170^2}{2 \times 30} = 482 \text{ W}$$

10.27 Find the average power absorbed by a 2.7- Ω resistor when the current $i = 1.2 \sin(377t + 30^\circ)$ A flows through it.

$$P_{av} = \frac{1}{2} I_m^2 R = 0.5(1.2)^2(2.7) = 1.94 \text{ W}$$

10.28 What is the peak voltage at a 120-V electric outlet?

The 120 V is the effective value of the sinusoidal voltage at the outlet. Since for a sinusoid the peak is $\sqrt{2}$ times the effective value, the peak voltage at the outlet is $\sqrt{2} \times 120 = 170$ V.

10.29 What is the reading of an ac voltmeter connected across a 680- Ω resistor that has a current of $i = 6.2 \cos(377t - 20^\circ)$ mA flowing through it?

The voltmeter reads the effective value of the resistor voltage, which can be found from I_{eff} and R . Since $V_m = I_m R$, then $V_m/\sqrt{2} = (I_m/\sqrt{2})(R)$ or $V_{\text{eff}} = I_{\text{eff}} R$. So,

$$V_{\text{eff}} = [(6.2 \times 10^{-3})/\sqrt{2}](680) = 2.98 \text{ V}$$

10.30 What is the reading of an ac voltmeter connected across a 10- Ω resistor that has a peak power dissipation of 40 W?

The peak voltage V_m can be found from the peak power: $P_m = V_m I_m = V_m^2/R$, from which $V_m = \sqrt{P_m R} = \sqrt{40(10)} = 20$ V. The effective or rms voltage, which is the voltmeter reading, is $V_m/\sqrt{2} = 20/\sqrt{2} = 14.1$ V.

10.31 What is the expression for a 240-Hz sine wave of voltage that has an rms value of 120 V?

Since the peak voltage is $120 \times \sqrt{2} = 170$ V and the radian frequency is $2\pi \times 240 = 1508$ rad/s, the sine wave is $v = 170 \sin 1508t$ V.

10.32 Find the effective value of a periodic voltage that has a value of 20 V for one half-period and -10 V for the other half-period.

The first step is to square the wave. The result is 400 for the first half-period and $(-10)^2 = 100$ for the second half-period. The next step is to find the average of the squares from the area divided by the period: $(400 \times T/2 + 100 \times T/2)/T = 250$. The last step is to find the square root of this average: $V_{\text{eff}} = \sqrt{250} = 15.8$ V.

10.33 Find the effective value of the periodic current shown in Fig. 10-11a.

Fig. 10-11

The first step is to square the wave, which has a period of 8 s. The squared wave is shown in Fig. 10-11*b*. The next step is to find the average of the squared wave, which can be found by dividing the area by the period: $[16(3) + 9(6 - 4)] / 8 = 8.25$. The last step is to find the square root of this average: $I_{\text{eff}} = \sqrt{8.25} = 2.87 \text{ A}$.

- 10.34** Find the reactances of a 120-mH inductor at (a) 0 Hz (dc), (b) 40 rad/s, (c) 60 Hz, and (d) 30 kHz.

From $X_L = \omega L = 2\pi fL$,

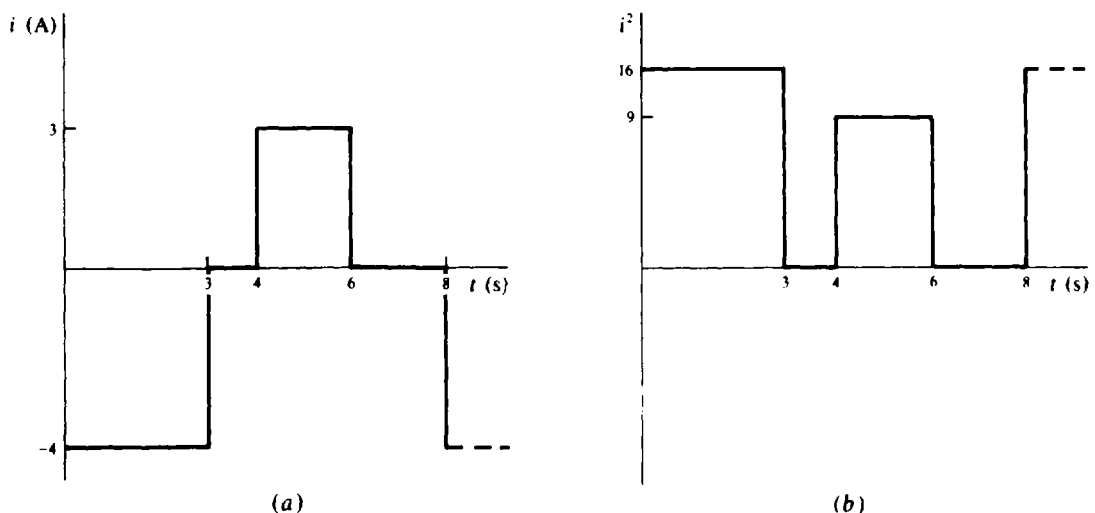
- (a) $X_L = 2\pi(0)(120 \times 10^{-3}) = 0 \Omega$
- (b) $X_L = 40(120 \times 10^{-3}) = 4.8 \Omega$
- (c) $X_L = 2\pi(60)(120 \times 10^{-3}) = 45.2 \Omega$
- (d) $X_L = 2\pi(30 \times 10^3)(120 \times 10^{-3}) \Omega = 22.6 \text{ k}\Omega$

- 10.35** Find the inductances of the inductors that have reactances of (a) 5 Ω at 377 rad/s, (b) 1.2 kΩ at 30 kHz, and (c) 1.6 MΩ at 22.5 MHz.

Solving for L in $X_L = \omega L$ results in $L = X_L / \omega = X_L / 2\pi f$. So,

- (a) $L = 5 / 377 \text{ H} = 13.3 \text{ mH}$
- (b) $L = (1.2 \times 10^3) / (2\pi \times 30 \times 10^3) \text{ H} = 6.37 \text{ mH}$
- (c) $L = (1.6 \times 10^6) / (2\pi \times 22.5 \times 10^6) \text{ H} = 11.3 \text{ mH}$

- 10.36** Find the frequencies at which a 250-mH inductor has reactances of 30 Ω and 50 kΩ.

From $X_L = \omega L = 2\pi fL$, the frequency is $f = X_L / 2\pi L$, and so

$$f_1 = \frac{30}{2\pi \times 250 \times 10^{-3}} = 19.1 \text{ Hz} \quad \text{and} \quad f_2 = \frac{50 \times 10^3}{2\pi \times 250 \times 10^{-3}} \text{ Hz} = 31.8 \text{ kHz}$$

- 10.37** What is the voltage across a 30-mH inductor that has a 40-mA, 60-Hz current flowing through it?

The specified current is, of course, the effective value, and the desired voltage is the effective value of voltage, although not specifically stated. In general, the ac current and voltage values given are effective values unless otherwise specified. Because $X_L = V_m / I_m$, it follows that $X_L = (V_m / \sqrt{2}) / (I_m / \sqrt{2}) = V_{\text{eff}} / I_{\text{eff}}$. So, here, $V_{\text{eff}} = I_{\text{eff}} X_L = (40 \times 10^{-3})(2\pi \times 60)(30 \times 10^{-3}) = 0.452 \text{ V}$.

- 10.38** The voltage $v = 30 \sin(200\pi t + 30^\circ) \text{ V}$ is across an inductor that has a reactance of 62 Ω. Find the inductor current and plot one cycle of the voltage and current on the same graph.

The current peak equals the voltage peak divided by the reactance: $I_m = 30 / 62 = 0.484 \text{ A}$. And, since the current lags the voltage by 90°,

$$i = 0.484 \sin(200\pi t + 30^\circ - 90^\circ) = 0.484 \sin(200\pi t - 60^\circ) \text{ A}$$

The voltage graph is the same as that shown in Fig. 10-10. The current graph for these values, though, differs from that in Fig. 10-10 by a shift right by a time corresponding to 90°, which time is one-fourth of a period: $10 / 4 = 2.5 \text{ ms}$. The waveforms are shown in Fig. 10-12.

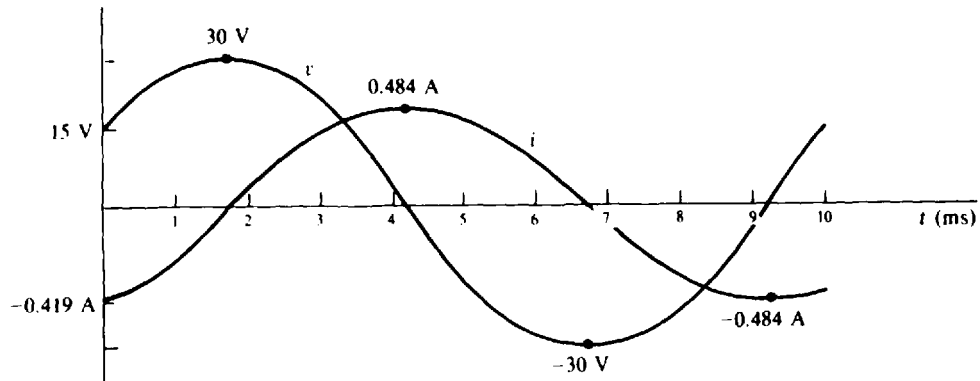

Fig. 10-12

10.39 Find the voltages across a 2-H inductor for the following currents:

(a) 10 A, (b) $10 \sin(377t + 10^\circ)$ A, and (c) $10 \cos(10^4t - 20^\circ)$ A. As always, assume associated references because there is no statement to the contrary.

(a) The inductor voltage is zero because the current is a constant and the time derivative of a constant is zero: $v = 2 \frac{d(10)}{dt} = 0$ V. From another point of view, the reactance is 0Ω because the frequency is 0 Hz, and so $V_m = I_m X_L = 10(0) = 0$ V.

(b) The voltage peak equals the current peak times the reactance of $377 \times 2 = 754 \Omega$:

$$V_m = I_m X_L = 10 \times 754 \text{ V} = 7.54 \text{ kV}$$

Since the voltage leads the current by 90° and since $\sin(x + 90^\circ) = \cos x$,

$$v = 7.54 \sin(377t + 10^\circ + 90^\circ) = 7.54 \cos(377t + 10^\circ) \text{ kV}$$

(c) Similarly, $V_m = I_m X_L = 10(10^4 \times 2) \text{ V} = 0.2 \text{ MV}$, and

$$v = 0.2 \cos(10^4t - 20^\circ + 90^\circ) = 0.2 \cos(10^4t + 70^\circ) \text{ MV}$$

10.40 Find the reactances of a $0.1\text{-}\mu\text{F}$ capacitor at (a) 0 Hz (dc), (b) 377 rad/s, (c) 30 kHz, and (d) 100 MHz.

From $X_C = -1/\omega C = -1/2\pi fC$,

$$(a) X_C = \lim_{\omega \rightarrow 0} \frac{-1}{\omega(0.1 \times 10^{-6})} \Omega \rightarrow -\infty \Omega \quad (\text{an open circuit})$$

$$(b) X_C = \frac{-1}{377(0.1 \times 10^{-6})} \Omega = -26.5 \text{ k}\Omega$$

$$(c) X_C = \frac{-1}{2\pi(30 \times 10^3)(0.1 \times 10^{-6})} \Omega = -53.1 \Omega$$

$$(d) X_C = \frac{-1}{2\pi(100 \times 10^6)(0.1 \times 10^{-6})} \Omega = -15.9 \text{ m}\Omega$$

10.41 Find the capacitances of capacitors that have a reactance of -500Ω at (a) 377 rad/s, (b) 10 kHz, and (c) 22.5 MHz.

Solving for C in $X_C = -1/\omega C$ results in $C = -1/\omega X_C = -1/(2\pi f \times X_C)$. So,

$$(a) C = \frac{-1}{377(-500)} \text{ F} = 5.31 \mu\text{F}$$

$$(b) \quad C = \frac{-1}{2\pi(10 \times 10^3)(-500)} \text{ F} = 0.0318 \text{ } \mu\text{F}$$

$$(c) \quad C = \frac{-1}{2\pi(22.5 \times 10^6)(-500)} \text{ F} = 14.1 \text{ pF}$$

10.42 Find the frequencies at which a 2- μF capacitor has reactances of -0.1 and $-2500 \text{ } \Omega$.

From $X_C = -1/\omega C = -1/2\pi fC$, the frequency is $f = -1/(X_C \times 2\pi C)$. So,

$$f_1 = \frac{-1}{-0.1 \times 2\pi \times 2 \times 10^{-6}} \text{ Hz} = 796 \text{ kHz} \quad \text{and} \quad f_2 = \frac{-1}{-2500 \times 2\pi \times 2 \times 10^{-6}} = 31.8 \text{ Hz}$$

10.43 What current flows through a 0.1- μF capacitor that has 200 V at 400 Hz across it?

Although not specifically stated, it should be understood that the effective capacitor voltage is specified and the effective capacitor current is to be found. If both sides of $I_m = \omega C V_m$ are divided by $\sqrt{2}$, the result is $I_m/\sqrt{2} = \omega C V_m/\sqrt{2}$ or $I_{\text{eff}} = \omega C V_{\text{eff}}$. So,

$$I_{\text{eff}} = 2\pi(400)(0.1 \times 10^{-6})(200) \text{ A} = 50.3 \text{ mA}$$

10.44 What is the voltage across a capacitor that carries a 120-mA current if the capacitive reactance is $-230 \text{ } \Omega$?

From the solution to Prob. 10.43, $I_{\text{eff}} = \omega C V_{\text{eff}}$ or $V_{\text{eff}} = I_{\text{eff}}(1/\omega C)$. Since $1/\omega C$ is the magnitude of capacitive reactance, the effective voltage and current of a capacitor have a relation of $V_{\text{eff}} = I_{\text{eff}}|X_C|$. Consequently, here, $V_{\text{eff}} = (120 \times 10^{-3})|-230| = 27.6 \text{ V}$.

10.45 The voltage $v = 30 \sin(200\pi t + 30^\circ) \text{ V}$ is across a capacitor that has a reactance of $-62 \text{ } \Omega$. Find the capacitor current and plot one cycle of the voltage and current on the same graph.

From $V_m I_m = 1/\omega C = |X_C|$, the current peak equals the voltage peak divided by the magnitude of capacitive reactance: $I_m = 30/|-62| = 0.484 \text{ A}$. And, since the current leads the voltage by 90° ,

$$i = 0.484 \sin(200\pi t + 30^\circ + 90^\circ) = 0.484 \cos(200\pi t + 30^\circ) \text{ A}$$

Notice that the current sinusoid has the same phase angle as the voltage sinusoid, but, because of the 90° lead, is a phase-shifted cosine wave instead of the phase-shifted sine wave of the voltage.

The voltage graph is the same as that in Fig. 10-10. The current graph differs from that in Fig. 10-10 by a shift left by a time corresponding to 90° , which time is one-fourth of a period: $10/4 = 2.5 \text{ ms}$. The waveforms are shown in Fig. 10-13.

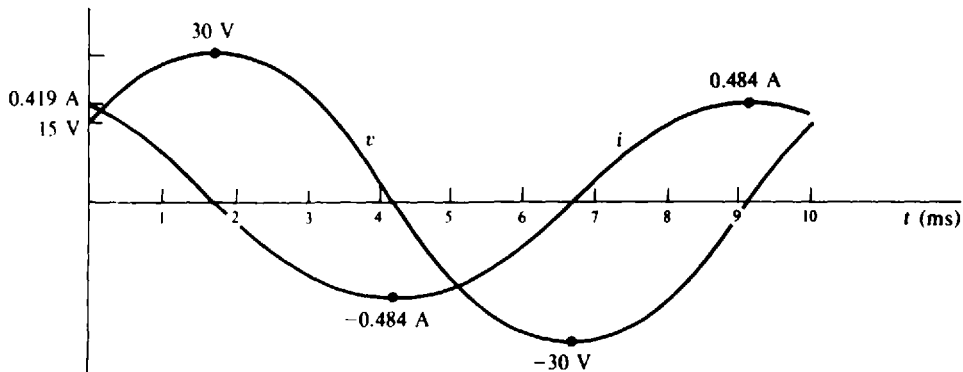

Fig. 10-13

- 10.46** What currents flow through a $2\text{-}\mu\text{F}$ capacitor for voltages of (a) $v = 5 \sin(377t + 10^\circ)$ V and (b) $v = 12 \cos(10^4t - 20^\circ)$ V?

(a) The current peak equals ωC times the voltage peak:

$$I_m = \omega C V_m = 377(2 \times 10^{-6})(5) \text{ A} = 3.77 \text{ mA}$$

Also, because the capacitor current leads the capacitor voltage by 90° and the voltage is a phase-shifted sine wave, the current can be expressed as a phase-shifted cosine wave with the same phase angle: $i = 3.77 \cos(377t + 10^\circ)$ mA.

(b) The current peak is

$$I_m = \omega C V_m = 10^4(2 \times 10^{-6})(12) = 0.24 \text{ A}$$

Also, the current leads the voltage by 90° . As a result,

$$i = 0.24 \cos(10^4t - 20^\circ + 90^\circ) = 0.24 \cos(10^4t + 70^\circ) \text{ A}$$

Supplementary Problems

- 10.47** Find the periods of periodic currents that have frequencies of (a) 1.2 mHz, (b) 2.31 kHz, and (c) 16.7 MHz.
Ans. (a) 833 s, (b) 433 μs , (c) 59.9 ns
- 10.48** What are the frequencies of periodic voltages that have periods of (a) 18.3 ps, (b) 42.3 s, and (c) 1 d?
Ans. (a) 546 GHz (gigahertz; i.e., 10^9 Hz), (b) 23.6 mHz, (c) 11.6 μHz
- 10.49** What are the period and frequency of a periodic current for which 423 cycles occur in 6.19 ms?
Ans. 14.6 μs , 68.3 kHz
- 10.50** Convert the following angles in degrees to angles in radians: (a) -40° , (b) -1123° , and (c) 78° .
Ans. (a) -0.698 rad, (b) -19.6 rad, (c) 1.36 rad
- 10.51** Convert the following angles in radians to angles in degrees: (a) 13.4 rad, (b) 0.675 rad, and (c) -11.7 rad.
Ans. (a) 768° , (b) 38.7° , (c) -670°
- 10.52** Find the periods of sinusoidal voltages that have radian frequencies of (a) 120π rad/s, (b) 0.625 rad/s, and (c) 62.1 krad/s.
Ans. (a) 16.7 ms, (b) 10.1 s, (c) 101 μs
- 10.53** Find the radian frequencies of sinusoidal currents that have periods of (a) 17.6 μs , (b) 4.12 ms, and (c) 1 d.
Ans. (a) 357 krad/s, (b) 1.53 krad/s, (c) 72.7 $\mu\text{rad/s}$
- 10.54** What are the amplitudes and frequencies of (a) $-63.7 \cos(754t - 50^\circ)$ and (b) $429 \sin(4000t + 15^\circ)$?
Ans. (a) 63.7, 120 Hz; (b) 429, 637 Hz
- 10.55** Find the instantaneous value of $i = 80 \sin 500t$ mA at (a) $t = 4$ ms and (b) $t = 2.1$ s.
Ans. (a) 72.7 mA, (b) 52 mA

10.56 What is the frequency of a sine wave of voltage which has a 45-V peak and which continuously increases from 0 V at $t = 0$ s to 24 V at $t = 46.2$ ms?

Ans. 1.94 Hz

10.57 If a voltage cosine wave has a peak value of 20 V at $t = 0$ s, and if it takes a minimum of 0.123 s for this voltage to decrease from 20 to 17 V, find the voltage at $t = 4.12$ s.

Ans. 19.3 V.

10.58 What is the instantaneous value of $i = 13.2 \cos(377t + 50^\circ)$ mA at (a) $t = -42.1$ ms and (b) $t = 6.3$ s?

Ans. (a) -10 mA, (b) 7.91 mA

10.59 Find an expression for a 400-Hz sinusoidal current that has a 2.3-A positive peak at $t = -0.45$ ms.

Ans. $i = 2.3 \cos(800\pi t + 64.8^\circ)$ A

10.60 Find an expression for a sinusoidal voltage that is 0 V at $t = -8.13$ ms, after which it increases to a peak of 15 V at $t = 6.78$ ms.

Ans. $v = 15 \sin(105t + 49.1^\circ)$ V

10.61 What is the shortest time required for a 4.3-krad/s sinusoid to increase from two-fifths to four-fifths of its peak value?

Ans. 120 μ s

10.62 If 43.7 V is the peak voltage induced in the conductor of the alternator shown in Fig. 10-2, find the voltage induced after the conductor has rotated through an angle of 43° from its horizontal position.

Ans. ± 29.8 V

10.63 If the conductor of the alternator in Fig. 10-2 is rotating at 400 Hz, and if the induced voltage has a 23-V peak, find the induced voltage 0.23 ms after the conductor passes through its vertical position.

Ans. ± 19.3 V

10.64 Find the periods of (a) $4 + 3 \sin(800\pi t - 15^\circ)$, (b) $8.1 \cos^2 9\pi t$, and (c) $8 \sin 16t \cos 16t$.

Ans. (a) 2.5 ms, (b) 111 ms, (c) 196 ms

10.65 Find the phase relations for the following pairs of sinusoids:

(a) $v = 6 \sin(30t - 40^\circ)$ V, $i = 10 \sin(30t - \pi/3)$ mA

(b) $v_1 = -8 \sin(40t - 80^\circ)$ V, $v_2 = -10 \sin(40t - 50^\circ)$ V

(c) $i_1 = 4 \cos(70t - 40^\circ)$ mA, $i_2 = -6 \cos(70t + 80^\circ)$ mA

(d) $v = -4 \sin(45t + 5^\circ)$ V, $i = 7 \cos(45t + 80^\circ)$ mA

Ans. (a) v leads i by 20° , (b) v_1 lags v_2 by 30° , (c) i_1 leads i_2 by 60° , (d) v leads i by 15°

10.66 Find the average value of a half-wave rectified sinusoidal voltage that has a peak of 12 V. This wave consists only of the positive half-cycles of the sinusoidal voltage. It is zero during the times that the sinusoidal is negative.

Ans. 3.82 V

10.67 Find the average values of the periodic waveforms shown in Fig. 10-14.

Ans. (a) 3.5, (b) 4, (c) 15

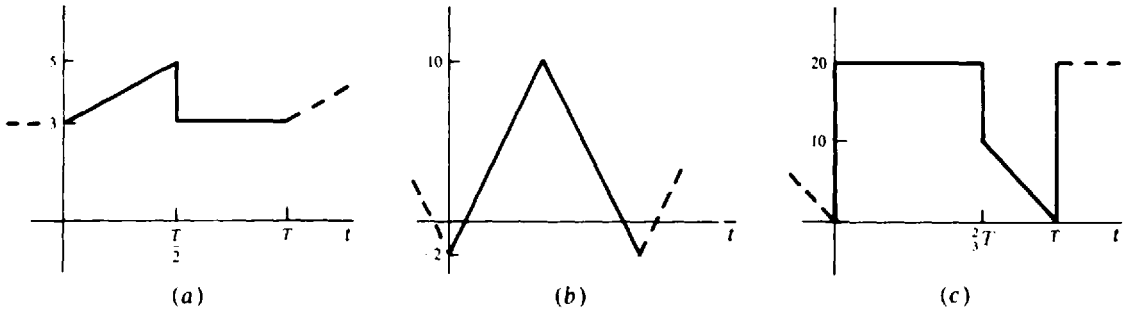

Fig. 10-14

- 10.68** What is the average power absorbed by a circuit component that has a voltage $v = 10 \text{ V}$ across it when a current $i = 5 + 6 \cos 33t \text{ A}$ flows through it?
Ans. 50 W
- 10.69** Find the average power absorbed by a circuit component that has a voltage $v = 20.3 \cos(754t - 10) \text{ V}$ across it when a current $i = 15.6 \cos(754t - 30) \text{ mA}$ flows through it.
Ans. 149 mW
- 10.70** What is the conductance of a resistor that has a voltage $v = 50.1 \sin(200\pi t + 30) \text{ V}$ across it when a current $i = 6.78 \sin(200\pi t + 30) \text{ mA}$ flows through it?
Ans. 135 μS
- 10.71** If the voltage $v = 150 \cos(377t + 45) \text{ V}$ is across a 33-k Ω resistor, what is the resistor current?
Ans. $i = 4.55 \cos(377t + 45) \text{ mA}$
- 10.72** Find the average power absorbed by an 82- Ω resistor that has a voltage $v = 311 \cos(377t - 45) \text{ V}$ across it.
Ans. 590 W
- 10.73** What is the average power absorbed by a 910- Ω resistor that has a current $i = 9.76 \sin(754t - 36) \text{ mA}$ flowing through it?
Ans. 43.3 mW
- 10.74** Find the average power absorbed by a resistor having a voltage $v = 87.7 \cos(400\pi t - 15) \text{ V}$ across it and a current $i = 2.72 \cos(400\pi t - 15) \text{ mA}$ flowing through it.
Ans. 119 mW
- 10.75** What is the reading of an ac ammeter that is in series with a 470- Ω resistor that has a voltage $v = 150 \cos(377t + 30) \text{ V}$ across it?
Ans. 226 mA
- 10.76** What is the reading of an ac ammeter that is in series with a 270- Ω resistor that has a peak power dissipation of 10 W?
Ans. 136 mA

- 10.77** What is the expression for a 400-Hz current cosine wave that has an effective value of 13.2 mA?
Ans. $i = 18.7 \cos 800\pi t$ mA
- 10.78** Find the effective value of $v = 3 + 2 \sin 4t$ V. (*Hint:* Use a sinusoidal identity in finding the average value of the squared voltage.)
Ans. 3.32 V
- 10.79** Find the effective value of a periodic current that has a value of 40 mA for two-thirds of a period and 25 mA for the remaining one-third of the period. Would the effective value be different if the current were -25 mA instead of 25 mA for the one-third period?
Ans. 35.7 mA, no
- 10.80** Find the effective value of a periodic current that in a 20-ms period has a value of 0.761 A for 4 ms, 0 A for 2 ms, -0.925 A for 8 ms, and 1.23 A for the remaining 6 ms. Would the effective value be different if the time segments were in seconds instead of in milliseconds?
Ans. 0.955 A, no
- 10.81** Find the reactances of a 180-mH inductor at (a) 754 rad/s, (b) 400 Hz, and (c) 250 kHz.
Ans. (a) 136 Ω , (b) 452 Ω , (c) 283 k Ω
- 10.82** Find the inductances of the inductors that have reactances of (a) 72.1 Ω at 754 rad/s, (b) 11.9 Ω at 12 kHz, and (c) 42.1 k Ω at 2.1 MHz.
Ans. (a) 95.6 mH, (b) 158 μ H, (c) 3.19 mH
- 10.83** What are the frequencies at which a 120-mH inductor has reactances of (a) 45 Ω and (b) 97.1 k Ω ?
Ans. (a) 59.7 Hz, (b) 129 kHz
- 10.84** What current flows through an 80-mH inductor that has 120 V at 60 Hz across it?
Ans. 3.98 A
- 10.85** What is the inductance of the inductor that will draw a current of 250 mA when connected to a 120-V, 60-Hz voltage source?
Ans. 1.27 H
- 10.86** What are the currents that flow in a 500-mH inductor for voltages of (a) $v = 170 \sin(400t + \pi/6)$ V and (b) $v = 156 \cos(1000t + 10^\circ)$ V?
Ans. (a) $i = 0.85 \sin(400t - 60^\circ)$ A, (b) $i = 0.312 \sin(1000t + 10^\circ)$ A
- 10.87** Find the reactances of a 0.25- μ F capacitor at (a) 754 rad/s, (b) 400 Hz, and (c) 2 MHz.
Ans. (a) -5.31 k Ω , (b) -1.59 k Ω , (c) -0.318 Ω
- 10.88** Find the capacitances of the capacitors that have reactances of (a) -700 Ω at 377 rad/s, (b) -450 Ω at 400 Hz, and (c) -1.23 k Ω at 25 kHz.
Ans. (a) 3.79 μ F, (b) 0.884 μ F, (c) 5.18 nF
- 10.89** Find the frequency at which a 0.1- μ F capacitor and a 120-mH inductor have the same magnitude of reactance.
Ans. 1.45 kHz
- 10.90** What is the capacitance of a capacitor that draws 150 mA when connected to a 100-V, 400-Hz voltage source?
Ans. 0.597 μ F

10.91 What are the currents that flow in a $0.5\text{-}\mu\text{F}$ capacitor for capacitor voltages of (a) $v = 190 \sin(377t + 15^\circ)$ V and (b) $v = 200 \cos(1000t - 40^\circ)$ V?

Ans. (a) $i = 35.8 \cos(377t + 15^\circ)$ mA, (b) $i = 0.1 \cos(1000t + 50^\circ)$ A

10.92 What are the voltages across a $2\text{-}\mu\text{F}$ capacitor for currents of (a) $i = 7 \sin(754t + 15^\circ)$ mA and (b) $i = 250 \cos(10^3t - 30^\circ)$ mA?

Ans. (a) $v = 4.64 \sin(754t - 75^\circ)$ V, (b) $v = 125 \sin(10^3t - 30^\circ)$ V

Complex Algebra and Phasors

INTRODUCTION

The best way to analyze almost all ac circuits is by using *complex algebra*. Complex algebra is an extension of the algebra of real numbers—the common algebra. In complex algebra, though, complex numbers are included along with their own special rules for addition, multiplication, subtraction, and division. As is explained in Chaps. 12 and 13, in ac circuit analysis, sinusoidal voltages and currents are *transformed* into complex numbers called *phasors*; resistances, inductances, and capacitances are transformed into complex numbers called *impedances*; and then complex algebra is applied in much the same way that ordinary algebra is applied in dc circuit analysis.

A scientific calculator will operate on complex numbers as readily as on real numbers. But still it is important to know how to perform the various operations on complex numbers without the use of a calculator.

IMAGINARY NUMBERS

The common numbers that everyone uses are *real numbers*. But these are not the only kind of numbers. There are also *imaginary numbers*. The name “imaginary” is misleading because it suggests that these numbers are only in the imagination, when actually they are just as much numbers as the common real numbers. Imaginary numbers were invented when it became necessary to have numbers that are square roots of negative numbers (no real numbers are). This inventing of numbers was not new since it had been preceded by the inventions of noninteger real numbers and negative real numbers.

Imaginary numbers need to be distinguished from real numbers because different rules must be applied in the mathematical operations involving them. There is no one universally accepted way of representing imaginary numbers. In the electrical field, however, it is standard to use the letter *j*, as in $j2$, $j0.01$, and $-j5.6$.

The rules for adding and subtracting imaginary numbers are the same as those for adding and subtracting real numbers except that the sums and differences are imaginary. To illustrate,

$$j3 + j9 = j12 \quad j12.5 - j3.4 = j9.1 \quad j6.25 - j8.4 = -j2.15$$

The multiplication rule, though, is different. The product of two imaginary numbers is a *real* number that is the *negative* of the product that would be found if the numbers were real numbers instead. For example,

$$j2(j6) = -12 \quad j4(-j3) = 12 \quad -j5(-j4) = -20$$

Also, $j1(j1) = -1$, from which $j1 = \sqrt{-1}$. Likewise, $j2 = \sqrt{-4}$, $j3 = \sqrt{-9}$, and so forth.

Sometimes powers of $j1$ appear in calculations. These can have values of 1, -1 , $j1$, and $-j1$, as can be shown by starting with $(j1)^2 = j1(j1) = -1$ and then progressively multiplying by $j1$ and evaluating. As an illustration, $(j1)^3 = j1(j1)^2 = j1(-1) = -j1$ and $(j1)^4 = j1(j1)^3 = j1(-j1) = 1$.

The product of a real number and an imaginary number is an imaginary number that, except for being imaginary, is the same as if the numbers were both real. For example, $3(j5) = j15$ and $-j5.1(4) = -j20.4$.

In the division of two imaginary numbers, the quotient is real and the same as if the numbers were real. As an illustration,

$$\frac{j8}{j4} = 2 \quad \text{and} \quad \frac{j20}{-j100} = -0.2$$

A convenient memory aid for division is to treat the j 's as if they are numbers and to divide them out as in

$$\frac{-j16}{-j2} = 8$$

This should be viewed as a memory aid only, because j just designates a number as being imaginary and is not a number itself. However, treating j as a number in division, as well as in the other mathematical operations, is often done because of convenience and the fact that it does give correct answers.

If an imaginary number is divided by a real number, the quotient is imaginary but otherwise the same as for real numbers. For example,

$$\frac{j16}{4} = j4 \quad \text{and} \quad \frac{j2.4}{-0.6} = -j4$$

The only difference if the denominator is imaginary and the numerator is real is that the quotient is the negative of the above. To illustrate,

$$\frac{1}{j1} = -j1 \quad \text{and} \quad \frac{-100}{j20} = j5$$

The basis for this rule can be shown by multiplying a numerator and denominator by $j1$, as in

$$\frac{225}{j5} = \frac{225 \times j1}{j5 \times j1} = \frac{j225}{-5} = -j45$$

Multiplying to make the denominator real, as here, is called *rationalizing*.

COMPLEX NUMBERS AND THE RECTANGULAR FORM

If a real number and an imaginary number are added, as in $3 + j4$, or subtracted, as in $6 - j8$, the result is considered to be a single *complex number* in *rectangular form*. Other forms of complex numbers are introduced in the next section.

A complex number can be represented by a point on the *complex plane* shown in Fig. 11.1. The horizontal axis, called the *real axis*, and the vertical axis, called the *imaginary axis*, divide the complex

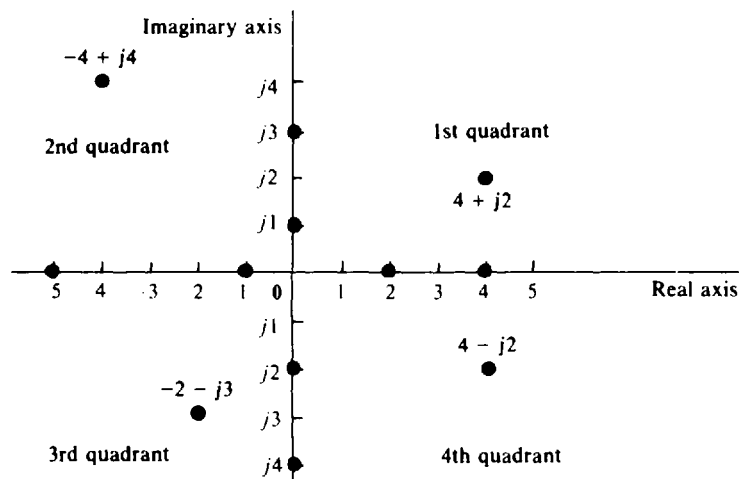

Fig. 11-1

plane into four quadrants, as labeled. Both axes have the same scale. The points for real numbers are on the real axis because a real number can be considered to be a complex number with a zero imaginary part. Figure 11-1 has four of these points: -5 , -1 , 2 , and 4 . The points for imaginary numbers are on the imaginary axis because an imaginary number can be considered to be a complex number with a zero real part. Figure 11-1 has four of these points: $j3$, $j1$, $-j2$, and $-j4$. Other complex numbers have nonzero real and imaginary parts, and so correspond to points off the axes. The real part of each number gives the position to the right or to the left of the vertical axis, and the imaginary part gives the position above or below the horizontal axis. Figure 11-1 has four of these numbers, one in each quadrant.

In Fig. 11-1 the complex numbers $4 + j2$ and $4 - j2$ have the same real part, and they also have the same imaginary part—except for sign. A pair of complex numbers having this relation are said to be *conjugates*: $4 + j2$ is the conjugate of $4 - j2$, and also $4 - j2$ is the conjugate of $4 + j2$. Points for conjugate numbers have the same horizontal position but opposite vertical positions, being equidistant on opposite sides of the real axis. If lines are drawn from the origin to these points, both lines will have the same length, and, except for sign, the same angle from the positive real axis. (Angles are positive if measured in a counterclockwise direction from this axis, and negative if measured in a clockwise direction.) These graphical relations of conjugates are important for the polar form of complex numbers presented in the next section.

The rectangular form is the only practical form for addition and subtraction. These operations are applied separately to the real and imaginary parts. As an illustration, $(3 + j4) + (2 + j6) = 5 + j10$ and $(6 - j7) - (4 - j2) = 2 - j5$.

In the multiplication of complex numbers in the rectangular form, the ordinary rules of algebra are used along with the rules for imaginary numbers. For example,

$$(2 + j4)(3 + j5) = 2(3) + 2(j5) + j4(3) + j4(j5) = 6 + j10 + j12 - 20 = -14 + j22$$

It follows from this multiplication rule that if a complex number is multiplied by its conjugate, the product is real and is the sum of the real part squared and the imaginary part squared. To illustrate,

$$(3 + j4)(3 - j4) = 3(3) + 3(-j4) + j4(3) + j4(-j4) = 9 - j12 + j12 + 16 = 9 + 16 = 3^2 + 4^2 = 25$$

In the division of complex numbers in rectangular form, the numerator and denominator are first multiplied by the conjugate of the denominator to make the denominator real, or rationalized, so that the division will be straightforward. As an example of this operation, consider

$$\frac{10 + j24}{6 + j4} = \frac{(10 + j24)(6 - j4)}{(6 + j4)(6 - j4)} = \frac{156 + j104}{6^2 + 4^2} = \frac{156 + j104}{52} = 3 + j2$$

POLAR FORM

The *polar form* of a complex number is a shorthand for the *exponential form*. Polar or exponential forms are usually the best forms for multiplying and dividing, but are not useful for adding and subtracting unless done graphically, which is rarely done. Typically, though, a scientific calculator can add and subtract complex numbers in polar form as well as in rectangular form. The exponential form is $Ae^{j\theta}$, where A is the *magnitude* and θ is the *angle* of the complex number. Also, $e = 2.718 \dots$ is the base of the natural logarithm. The polar shorthand for $Ae^{j\theta}$ is A/θ as in $4e^{j45^\circ} = 4/\underline{45^\circ}$ and in $-8e^{j60^\circ} = -8/\underline{60^\circ}$. Although both forms are equivalent, the polar form is much more popular because it is easier to write.

That a number such as $5e^{j60^\circ}$ is a complex number is evident from *Euler's identity*: $e^{j\theta} = \cos \theta + j \sin \theta$. As an illustration, $7e^{j30^\circ} = 7/\underline{30^\circ} = 7 \cos 30^\circ + j7 \sin 30^\circ = 6.06 + j3.5$. This use of Euler's identity not only shows that a number such as $Ae^{j\theta} = A/\underline{\theta}$ is a complex number, but also gives a method for converting a number from exponential or polar form to rectangular form.

Another use of Euler's identity is for deriving formulas for converting a complex number from rectangular form to the exponential and polar forms. Suppose that x and y are known in $x + jy$, and that A and θ are to be found such that $x + jy = Ae^{j\theta} = A/\underline{\theta}$. By Euler's identity, $x + jy = A \cos \theta + jA \sin \theta$. Since two complex numbers are equal only if the real parts are equal and if the imaginary parts are equal, it follows that $x = A \cos \theta$ and $y = A \sin \theta$. Taking the ratio of these equations eliminates A :

$$\frac{A \sin \theta}{A \cos \theta} = \tan \theta = \frac{y}{x} \quad \text{from which} \quad \theta = \tan^{-1} \frac{y}{x}$$

(Note that if x is negative, 180° must be either added to or subtracted from θ .) So, θ can be found from the arctangent of the ratio of the imaginary part to the real part. With θ known, A can be found by substituting θ into either $x = A \cos \theta$ or into $y = A \sin \theta$.

Another popular way of finding A is from a formula based on squaring both sides of $A \cos \theta = x$ and of $A \sin \theta = y$ and adding:

$$A^2 \cos^2 \theta + A^2 \sin^2 \theta = A^2(\cos^2 \theta + \sin^2 \theta) = x^2 + y^2$$

But since, from trigonometry, $\cos^2 \theta + \sin^2 \theta = 1$, it follows that $A^2 = x^2 + y^2$ and $A = \sqrt{x^2 + y^2}$. So, the magnitude of a complex number equals the square root of the sum of the squares of the real and imaginary parts. Most scientific calculators have a built-in feature for converting between rectangular and polar forms.

This conversion can also be understood from a graphical consideration. Figure 11-2a shows a directed line from the origin to the point for the complex number $x + jy$. As shown in Fig. 11-2b, this line forms a right triangle with its horizontal and vertical projections. From elementary trigonometry, $x = A \cos \theta$, $y = A \sin \theta$, and $A = \sqrt{x^2 + y^2}$, in agreement with the results from Euler's identity. Often this line, instead of the point, is considered to correspond to a complex number because its length and angle are the amplitude and angle of the complex number in polar form.

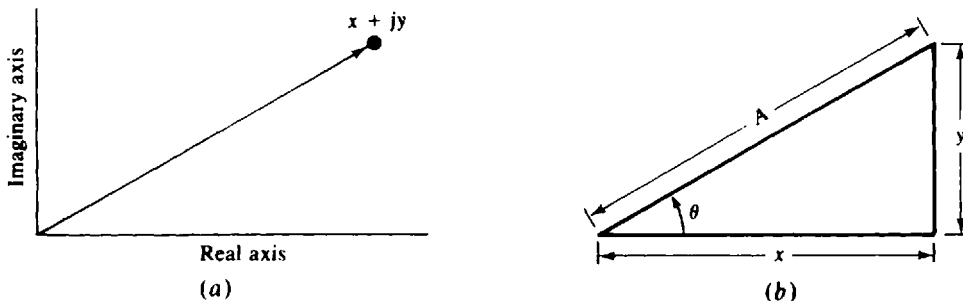

Fig. 11-2

As has been mentioned, the conjugate of a complex number in rectangular form differs only in the sign of the imaginary part. In polar form this difference appears as a difference in sign of the angle, as can be shown by converting any two conjugates to polar form. For example, $6 + j5 = 7.81/39.8^\circ$ and its conjugate is $6 - j5 = 7.81/-39.8^\circ$.

As stated, the rectangular form is best for adding and subtracting, and the polar form is often best for multiplying and dividing. The multiplication and division formulas for complex numbers in polar form are easy to derive from the corresponding exponential numbers and the law of exponents. The product of the complex numbers $Ae^{j\theta}$ and $Be^{j\phi}$ is $(Ae^{j\theta})(Be^{j\phi}) = AB e^{j(\theta + \phi)}$, which has a magnitude AB that is the product of the individual magnitudes and an angle $\theta + \phi$ that, by the law of exponents, is the sum of the individual angles. In polar form this is $A/\underline{\theta} \times B/\underline{\phi} = AB/\underline{\theta + \phi}$.

For division the result is

$$\frac{Ae^{j\theta}}{Be^{j\phi}} = \frac{A}{B} e^{j(\theta-\phi)} \quad \text{which in polar form is} \quad \frac{A/\theta}{B/\phi} = \frac{A}{B} / \theta - \phi$$

So, the magnitude of the quotient is the quotient A/B of the magnitudes, and the angle of the quotient is, by the law of exponents, the difference $\theta - \phi$ of the numerator angle minus the denominator angle.

PHASORS

By definition, a *phasor* is a complex number associated with a phase-shifted sine wave such that, if the phasor is in polar form, its magnitude is the effective (rms) value of the voltage or current and its angle is the phase angle of the phase-shifted sine wave. For example, $\mathbf{V} = 3/45^\circ \text{ V}$ is the phasor for $v = 3\sqrt{2} \sin(377t + 45^\circ) \text{ V}$ and $\mathbf{I} = 0.439/-27^\circ \text{ A}$ is the phasor for $i = 0.621 \sin(754t - 27^\circ) \text{ A}$. Of course, $0.621 = \sqrt{2}(0.439)$.

Note the use of the boldface letters \mathbf{V} and \mathbf{I} for the phasor voltage and current quantity symbols. It is conventional to use boldface letter symbols for *all* complex quantities. Also, a superscript asterisk is used to designate a conjugate. As an illustration, if $\mathbf{V} = -6 + j10 = 11.7/121^\circ \text{ V}$, then $\mathbf{V}^* = -6 - j10 = 11.7/-121^\circ \text{ V}$. The magnitude of a phasor variable is indicated by using lightface, and the magnitude of a complex number is indicated by using parallel lines. For example, if $\mathbf{I} = 3 + j4 = 5/53.1^\circ \text{ A}$, then $I = |3 + j4| = |5/53.1^\circ| = 5 \text{ A}$.

A common error is to equate a phasor and its corresponding sinusoid. They cannot be equal because the phasor is a complex constant, but the sinusoid is a real function of time. In short, it is *wrong* to write something like $3/30^\circ = 3\sqrt{2} \sin(\omega t + 30^\circ)$.

Phasors are usually shown in the polar form for convenience. But the rectangular form is just as correct because, being a complex number, a phasor can be expressed in any of the complex number forms. Not all complex numbers, though, are phasors—just those corresponding to sinusoids.

There is not complete agreement on the definition of a phasor. Many electrical engineers use the sinusoidal peak value instead of the effective value. Also, they use the angle from the phase-shifted cosine wave instead of the sine wave.

One use of phasors is for summing sinusoids of the *same* frequency. If each sinusoid is transformed into a phasor and the phasors added and then reduced to a single complex number, this number is the phasor for the sum sinusoid. As an illustration, the single sinusoid corresponding to $v = 3 \sin(2t + 30^\circ) + 2 \sin(2t - 15^\circ) \text{ V}$ can be found by adding the corresponding phasors,

$$\mathbf{V} = \frac{3}{\sqrt{2}}/30^\circ + \frac{2}{\sqrt{2}}/-15^\circ = \frac{4.64}{\sqrt{2}}/12.2^\circ \text{ V}$$

and then transforming the sum phasor to a sinusoid. The result is $v = 4.64 \sin(2t + 12.2^\circ) \text{ V}$. This procedure works for any number of sinusoids being added and subtracted, provided that all have the same frequency.

Notice that using $\sqrt{2}$ did not contribute anything to the final result. The $\sqrt{2}$ was introduced in finding the phasors, and then deleted in transforming the sum phasor to a sinusoid. When the problem statement is in sinusoids and the answer is to be a sinusoid, it is easier to neglect the $\sqrt{2}$ and use phasors that are based on peak values instead of rms values.

Phasors are sometimes shown on a complex plane in a diagram called a *phasor diagram*. The phasors are shown as arrows directed out from the origin with lengths corresponding to the phasor magnitudes, and arranged at angles that are the corresponding phasor angles. Such diagrams are convenient for showing the angular relations among voltages and currents of the same frequency. Sometimes they are also used for adding and subtracting, but not if accuracy is important.

Another diagram, called a *funicular diagram*, is more convenient for graphical addition and subtraction. In this type of diagram the adding and subtracting are the same as for vectors. For adding,

the arrows of the phasors are placed end to end and the sum phasor is found by drawing an arrow from the tail of the first arrow to the tip of the last. If a phasor is to be subtracted, its arrow is rotated 180 (reversed) and then added.

Solved Problems

11.1 Perform the following operations:

$$(a) \quad j2 + j3 - j6 - j8 \quad (b) \quad j2(-j3)(j4)(-j6) \quad (c) \quad \frac{1}{j0.25} \quad (d) \quad \frac{j100}{j8}$$

(a) The rules for adding and subtracting imaginary numbers are the same as for adding and subtracting real numbers, except that the result is imaginary. So,

$$j2 + j3 - j6 - j8 = j5 - j14 = -j9$$

(b) The numbers can be multiplied two at a time, with the result

$$[j2(-j3)][j4(-j6)] = 6(24) = 144$$

Alternatively, $j1$ can be factored from each factor and a power of $j1$ found times a product of real numbers:

$$j2(-j3)(j4)(-j6) = (j1)^4[2(-3)(4)(-6)] = 1(144) = 144$$

(c) The denominator can be made real by multiplying the numerator and denominator by $j1$, and then division performed as if the numbers were real—except that the quotient is imaginary:

$$\frac{1}{j0.25} = \frac{1(j1)}{j0.25(j1)} = \frac{j1}{-0.25} = -j4$$

Alternatively, since $1/j1 = -j1$,

$$\frac{1}{j0.25} = \frac{1}{j1} \left(\frac{1}{0.25} \right) = -j1(4) = -j4$$

(d) For convenience, the j 's can be considered to be numbers and divided out:

$$\frac{j100}{j8} = \frac{j100}{j8} = 12.5$$

11.2 Add or subtract as indicated, and express the results in rectangular form:

$$(a) \quad (6.21 + j3.24) + (4.13 - j9.47)$$

$$(b) \quad (7.34 - j1.29) - (5.62 + j8.92)$$

$$(c) \quad (-24 + j12) - (-36 - j16) - (17 - j24)$$

The real and imaginary parts are separately added or subtracted:

$$(a) \quad (6.21 + j3.24) + (4.13 - j9.47) = (6.21 + 4.13) + j(3.24 - 9.47) = 10.34 - j6.23$$

$$(b) \quad (7.34 - j1.29) - (5.62 + j8.92) = (7.34 - 5.62) - j(1.29 + 8.92) = 1.72 - j10.21$$

$$(c) \quad (-24 + j12) - (-36 - j16) - (17 - j24) = (-24 + 36 - 17) + j(12 + 16 + 24) = -5 + j52$$

11.3 Find the following products and express them in rectangular form:

$$(a) \quad (4 + j2)(3 + j4) \quad (b) \quad (6 + j2)(3 - j5)(2 - j3)$$

In the multiplication of complex numbers in rectangular form, the ordinary rules of algebra are used along with the rules for imaginary numbers:

(a) $(4 + j2)(3 + j4) = 4(3) + 4(j4) + j2(3) + j2(j4) = 12 + j16 + j6 - 8 = 4 + j22$

(b) It is best to multiply two numbers at a time:

$$(6 + j2)(3 - j5)(2 - j3) = [6(3) + 6(-j5) + j2(3) + j2(-j5)](2 - j3) = (18 - j30 + j6 + 10)(2 - j3)$$

$$= (28 - j24)(2 - j3) = 28(2) + 28(-j3) + (-j24)(2) + (-j24)(-j3)$$

$$= 56 - j84 - j48 - 72 = -16 - j132$$

Multiplying three or more complex numbers in rectangular form usually requires more work than does converting them to polar form and multiplying.

11.4 Evaluate

$$\begin{vmatrix} 4 + j3 & -j2 \\ -j2 & 5 - j6 \end{vmatrix}$$

The value of this second-order determinant equals the product of the elements on the principal diagonal minus the product of the elements on the other diagonal, the same as for one with real elements:

$$\begin{vmatrix} 4 + j3 & -j2 \\ -j2 & 5 - j6 \end{vmatrix} = (4 + j3)(5 - j6) - (-j2)(-j2) = 20 - j24 + j15 + 18 + 4 = 42 - j9$$

11.5 Evaluate

$$\begin{vmatrix} 4 + j6 & -j4 & -2 \\ -j4 & 6 + j10 & -3 \\ -2 & -3 & 2 + j1 \end{vmatrix}$$

The evaluation of a third-order determinant with complex elements is the same as for one with real elements:

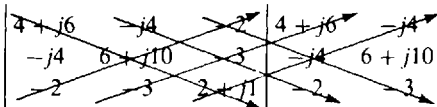

$$= (4 + j6)(6 + j10)(2 + j1) + (-j4)(-3)(-2) + (-2)(-j4)(-3) - (-2)(6 + j10)(-2)$$

$$- (-3)(-3)(4 + j6) - (2 + j1)(-j4)(-j4)$$

$$= -148 + j116 - j24 - j24 - 24 - j40 - 36 - j54 + 32 + j16 = -176 - j10$$

Although this procedure is straightforward, it is difficult to do without making errors. Using a calculator is much better.

11.6 Find the following quotients in rectangular form:

(a) $\frac{1}{0.2 + j0.5}$ (b) $\frac{14 + j5}{4 - j1}$

For division in the rectangular form, the numerator and denominator should be multiplied by the conjugate of the denominator to make the denominator real. Then the division is straightforward. Doing this results in

(a) $\frac{1}{0.2 + j0.5} \times \frac{0.2 - j0.5}{0.2 - j0.5} = \frac{0.2 - j0.5}{0.2^2 + 0.5^2} = \frac{0.2 - j0.5}{0.29} = \frac{0.2}{0.29} - j \frac{0.5}{0.29} = 0.69 - j1.72$

(b) $\frac{14 + j5}{4 - j1} \times \frac{4 + j1}{4 + j1} = \frac{51 + j34}{17} = 3 + j2$

11.7 Convert the following numbers to polar form:

(a) $6 + j9$ (b) $-21.4 + j33.3$ (c) $-0.521 - j1.42$ (d) $4.23 + j4.23$

If a calculator is used that does not have a rectangular-to-polar conversion feature, then a complex number $x + jy$ can be converted to its equivalent A/θ with the formulas $A = \sqrt{x^2 + y^2}$ and $\theta = \tan^{-1}(y/x)$. With this approach

(a) $6 + j9 = \sqrt{6^2 + 9^2} / \tan^{-1}(9/6) = 10.8/56.3$

(b) $-21.4 + j33.3 = \sqrt{(-21.4)^2 + 33.3^2} / \tan^{-1}[33.3/(-21.4)] = 39.6/122.7$

Typically, a calculator will give $\tan^{-1}(-33.3/21.4) = -57.3^\circ$, which differs from the correct angle by 180° . For such a calculator, this error of 180° always occurs in a rectangular-to-polar form conversion whenever the real part of the complex number is negative. The solution, of course, is to change the calculator angle by either positive or negative 180° , whichever is more convenient.

(c) $-0.521 - j1.42 = \sqrt{(-0.521)^2 + (-1.42)^2} / \tan^{-1}[-1.42/(-0.521)] = 1.51/-110$

Again, because the real part is negative, a calculator may not give an angle of -110° , but $\tan^{-1}(1.42/0.521) = 70^\circ$, instead,

(d) $4.23 + j4.23 = \sqrt{4.23^2 + 4.23^2} / \tan^{-1}(4.23/4.23) = \sqrt{2}(4.23) / \tan^{-1} 1 = 5.98/45^\circ$

As can be generalized from this result, when the magnitudes of the real and imaginary parts are equal, the polar magnitude is $\sqrt{2}$ times this magnitude. Also, the angle is 45° if the number is in the first quadrant of the complex plane, 135° if it is in the second, -135° if it is in the third, and -45° if it is in the fourth.

11.8 Convert the following numbers to rectangular form:

(a) $10.2/20^\circ$ (b) $6.41/-30^\circ$ (c) $-142/-80.3^\circ$ (d) $142/-260.3^\circ$ (e) $-142/-440.3^\circ$

If a calculator is used that does not have a polar-to-rectangular conversion feature, then Euler's identity can be used: $A/\theta = A \cos \theta + jA \sin \theta$. With this approach

(a) $10.2/20^\circ = 10.2 \cos 20^\circ + j10.2 \sin 20^\circ = 9.58 + j3.49$

(b) $6.41/-30^\circ = 6.41 \cos(-30^\circ) + j6.41 \sin(-30^\circ) = 5.55 - j3.21$

(c) $-142/-80.3^\circ = -142 \cos(-80.3^\circ) - j142 \sin(-80.3^\circ) = -23.9 + j140$

(d) $142/-260.3^\circ = 142 \cos(-260.3^\circ) + j142 \sin(-260.3^\circ) = -23.9 + j140$

(e) $-142/-440.3^\circ = -142 \cos(-440.3^\circ) - j142 \sin(-440.3^\circ) = -23.9 + j140$

Parts (c) and (d) show that an angular difference of 180° corresponds to multiplying by -1 . And parts (c) and (e) show that an angular difference of 360° has no effect. So, in general, $A/\theta \pm 180^\circ = -A/\theta$ and $A/\theta \pm 360^\circ = A/\theta$.

11.9 Find the following products in polar form:

(a) $(3/25^\circ)(4/-60^\circ)(-5/120^\circ)(-6/-210^\circ)$ (b) $(0.3 + j0.4)(-5 + j6)(7/35^\circ)(-8 - j9)$

(a) When all the factors are in polar form, the magnitude of the product is the product of the individual magnitudes along with negative signs, if any, and the angle of the product is the sum of the individual angles. So,

$$(3/25^\circ)(4/-60^\circ)(-5/120^\circ)(-6/-210^\circ) = 3(4)(-5)(-6)/25^\circ - 60^\circ + 120^\circ - 210^\circ = 360/-125^\circ$$

(b) The numbers in rectangular form must be converted to polar form before being multiplied:

$$(0.3 + j0.4)(-5 + j6)(7/35^\circ)(-8 - j9) = (0.5/53.1^\circ)(7.81/129.8^\circ)(7/35^\circ)(12.04/-131.6^\circ) \\ = 0.5(7.81)(7)(12.04)/53.1^\circ + 129.8^\circ + 35^\circ - 131.6^\circ = 329/86.3^\circ$$

11.10 Find the quotients in polar form for (a) $(81/45^\circ)/(3/16^\circ)$ and (b) $(-9.1/20^\circ)/(-4 + j7)$.

- (a) When the numerator and denominator are in polar form, the magnitude of the quotient is the quotient of the magnitudes, and the angle of the quotient is the angle of the numerator minus the angle of the denominator. So,

$$\frac{81/45^\circ}{3/16} = \frac{81}{3} / \underline{45^\circ - 16} = 27/29$$

- (b) The denominator should be converted to polar form as a first step:

$$\frac{-9.1/20^\circ}{-4 + j7} = \frac{-9.1/20^\circ}{8.06/119.7} = -\frac{9.1}{8.06} / \underline{20^\circ - 119.7^\circ} = -1.13/\underline{-99.7^\circ} = 1.13/\underline{-99.7^\circ + 180^\circ} = 1.13/80.3$$

- 11.11** Find the following quotient:

$$\frac{(1.2/35^\circ)^3(4.2/-20^\circ)^6}{(2.1/-10^\circ)^4(-3 + j6)^5}$$

Since each exponent of a number indicates how many times the number is to be multiplied by itself, the effect of an exponent is to raise the number magnitude to this exponent and to multiply the number angle by this exponent. Thus,

$$\begin{aligned} \frac{(1.2/35^\circ)^3(4.2/-20^\circ)^6}{(2.1/-10^\circ)^4(-3 + j6)^5} &= \frac{(1.2/35^\circ)^3(4.2/-20^\circ)^6}{(2.1/-10^\circ)^4(6.71/117^\circ)^5} = \frac{1.2^3(4.2)^6/3(35^\circ) - 6(20^\circ)}{2.1^4(6.71)^5/4(-10^\circ) + 5(117^\circ)} \\ &= \frac{1.73(5489)/-15^\circ}{19.4(13\,584)/543} = \frac{9.49 \times 10^3/-15^\circ}{2.64 \times 10^5/543} = 0.0359/\underline{-558^\circ} = 0.0359/\underline{-198^\circ} = -0.0359/\underline{-18^\circ} \end{aligned}$$

- 11.12** Find the corresponding phasor voltages and currents for the following:

- (a) $v = \sqrt{2}(50) \sin(377t - 35^\circ) \text{ V}$ (c) $v = 83.6 \cos(400t - 15^\circ) \text{ V}$
 (b) $i = \sqrt{2}(90.4) \sin(754t + 48^\circ) \text{ mA}$ (d) $i = 3.46 \cos(815t + 30^\circ) \text{ A}$

A phasor in polar form has a magnitude that is the effective value of the corresponding sinusoidal voltage or current, and an angle that is the phase angle of the sinusoid if it is in phase-shifted sine-wave form. So,

- (a) $v = \sqrt{2}(50) \sin(377t - 35^\circ) \text{ V} \rightarrow \mathbf{V} = 50/\underline{-35^\circ} \text{ V}$
 (b) $i = \sqrt{2}(90.4) \sin(754t + 48^\circ) \text{ mA} \rightarrow \mathbf{I} = 90.4/\underline{48^\circ} \text{ mA}$
 (c) $v = 83.6 \cos(400t - 15^\circ) = 83.6 \sin(400t - 15^\circ + 90^\circ) = 83.6 \sin(400t + 75^\circ) \text{ V}$
 $\rightarrow \mathbf{V} = (83.6/\sqrt{2})/\underline{75^\circ} = 59.1/\underline{75^\circ} \text{ V}$
 (d) $i = 3.46 \cos(815t + 30^\circ) = 3.46 \sin(815t + 30^\circ + 90^\circ) = 3.46 \sin(815t + 120^\circ) \text{ A}$
 $\rightarrow \mathbf{I} = (3.46/\sqrt{2})/\underline{120^\circ} = 2.45/\underline{120^\circ} \text{ A}$

- 11.13** Find the voltages and currents corresponding to the following phasor voltages and currents (each sinusoid has a radian frequency of 377 rad/s):

- (a) $\mathbf{V} = 20/35^\circ \text{ V}$ (b) $\mathbf{I} = 10.2/\underline{-41^\circ} \text{ mA}$ (c) $\mathbf{V} = 4 - j6 \text{ V}$ (d) $\mathbf{I} = -3 + j1 \text{ A}$

If a phasor is in polar form, the corresponding voltage or current is a phase-shifted sine wave that has a phase angle that is the phasor angle, and a peak value that is the $\sqrt{2}$ times the phasor magnitude. Thus,

- (a) $\mathbf{V} = 20/35^\circ \text{ V} \rightarrow v = 20\sqrt{2} \sin(377t + 35^\circ) = 28.3 \sin(377t + 35^\circ) \text{ V}$
 (b) $\mathbf{I} = 10.2/\underline{-41^\circ} \text{ mA} \rightarrow i = \sqrt{2}(10.2) \sin(377t - 41^\circ) = 14.4 \sin(377t - 41^\circ) \text{ mA}$
 (c) $\mathbf{V} = 4 - j6 = 7.21/\underline{-56.3^\circ} \text{ V} \rightarrow v = \sqrt{2}(7.21) \sin(377t - 56.3^\circ) = 10.2 \sin(377t - 56.3^\circ) \text{ V}$
 (d) $\mathbf{I} = -3 + j1 = 3.16/\underline{161.6^\circ} \text{ A} \rightarrow i = \sqrt{2}(3.16) \sin(377t + 161.6^\circ) = 4.47 \sin(377t + 161.6^\circ) \text{ A}$

11.14 Find a single sinusoid that is the equivalent of each of the following:

(a) $6.23 \sin \omega t + 9.34 \cos \omega t$

(b) $5 \sin(4t - 20^\circ) + 6 \sin(4t + 45^\circ) - 7 \cos(4t - 60^\circ) + 8 \cos(4t + 30^\circ)$

(c) $5 \sin 377t + 6 \cos 754t$

A phasor approach can be used since the terms are sinusoids. The procedure is to find the phasor corresponding to each sinusoid, add the phasors to obtain a single complex number, and then find the sinusoid corresponding to this number. Preferably the phasors are based on peak values because there is no advantage in introducing a factor of $\sqrt{2}$ since the problems statements are in sinusoids and the answers are to be in sinusoids. Thus,

(a) $6.23 \sin \omega t + 9.34 \cos \omega t \rightarrow 6.23/\underline{0} + 9.34/\underline{90} = 11.2/\underline{56.3} \rightarrow 11.2 \sin(\omega t + 56.3^\circ)$

(b) $5 \sin(4t - 20^\circ) + 6 \sin(4t + 45^\circ) - 7 \cos(4t - 60^\circ) + 8 \cos(4t + 30^\circ)$

$\rightarrow 5/\underline{-20} + 6/\underline{45} - 7/\underline{30} + 8/\underline{120} = 6.07/\underline{100.7} = -6.07/\underline{-79.3} \rightarrow -6.07 \sin(4t - 79.3^\circ)$

(c) The sinusoids cannot be combined because they have different frequencies.

11.15 For the circuit shown in Fig. 11-3, find v_s if $v_1 = 10.2 \sin(754t + 30^\circ)$ V, $v_2 = 14.9 \sin(754t - 10^\circ)$ V, and $v_3 = 16.1 \cos(754t - 25^\circ)$ V.

By KVL, $v_s = v_1 - v_2 + v_3 = 10.2 \sin(754t + 30^\circ) - 14.9 \sin(754t - 10^\circ) + 16.1 \cos(754t - 25^\circ)$ V
The sum sinusoid can be found by using phasors:

$$V_s = V_1 - V_2 + V_3 = \frac{10.2}{\sqrt{2}} \underline{/30} - \frac{14.9}{\sqrt{2}} \underline{/ -10} + \frac{16.1}{\sqrt{2}} \underline{/65} = \frac{22.3}{\sqrt{2}} \underline{/87.5} \text{ V}$$

$$\rightarrow v_s = 22.3 \sin(754t + 87.5^\circ) \text{ V}$$

Since the problem statement is in sinusoids and the final result is a sinusoid, finding the solution would have been slightly easier using phasors based on peak rather than rms values.

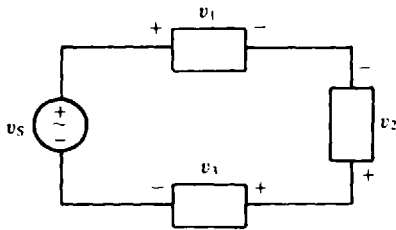

Fig. 11-3

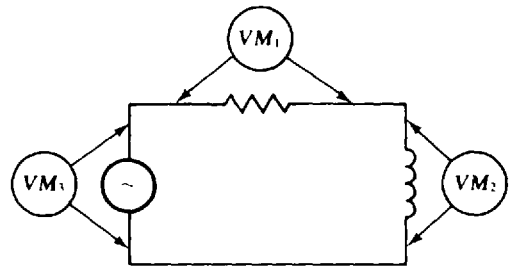

Fig. 11-4

11.16 In the circuit shown in Fig. 11-4, voltmeters VM_1 and VM_2 have readings of 40 and 30 V, respectively. Find the reading of voltmeter VM_3 .

It is tempting to conclude that, by KVL, the reading of voltmeter VM_3 is the sum of the readings of voltmeters VM_1 and VM_2 . But this is *wrong* because KVL applies to phasor voltages and not to the rms voltages of the voltmeter readings. The rms voltages, being positive real constants, do not have the angles that the phasor voltages have.

For the phasors required for KVL, angles must be associated with the given rms voltages. One angle can be arbitrarily selected because only the magnitude of the sum is desired. If 0° is selected for the resistor voltage phasor, this phasor is $40/\underline{0}$ V and then that for the inductor voltage must be $30/\underline{90}$ V. The inductor voltage phasor has a 90° greater angle because this voltage leads the current by 90° , but the resistor voltage

is in phase with the current. By KVL, the phasor voltage for the source is $40 + 30/90^\circ = 40 + j30 = 50/36.9^\circ$ V, which has an rms value of 50 V. So, the reading of voltmeter VM_3 is 50 V, and not the $30 + 40 = 70$ V that might at first be supposed.

11.17 Find v_s for the circuit shown in Fig. 11-5.

The voltage v_s can be determined from $v_s = v_R + v_L + v_C$ after these component voltages are found. By Ohm's law,

$$v_R = [0.234 \sin(3000t - 10^\circ)](270) = 63.2 \sin(3000t - 10^\circ) \text{ V}$$

The inductor voltage v_L leads the current by 90° and has a peak value of $\omega L = 3000(120 \times 10^{-3}) = 360$ times the peak value of the current:

$$v_L = 360(0.234) \sin(3000t - 10^\circ + 90^\circ) = 84.2 \sin(3000t + 80^\circ) \text{ V}$$

The capacitor voltage v_C lags the current by 90° and has a peak value that is $1/\omega C = 1/(3000 \times 6 \times 10^{-6}) = 55.6$ times the peak value of the current:

$$v_C = 55.6(0.234) \sin(3000t - 10^\circ - 90^\circ) = 13 \sin(3000t - 100^\circ) \text{ V}$$

Phasors, which are conveniently based on peak values, can be used to find the sum sinusoid:

$$\begin{aligned} \mathbf{V}_S &= \mathbf{V}_R + \mathbf{V}_L + \mathbf{V}_C = 63.2/\underline{-10^\circ} + 84.2/\underline{80^\circ} + 13/\underline{-100^\circ} = 95.2/\underline{38.4^\circ} \text{ V} \\ \rightarrow v_s &= 95.2 \sin(3000t + 38.4^\circ) \text{ V} \end{aligned}$$

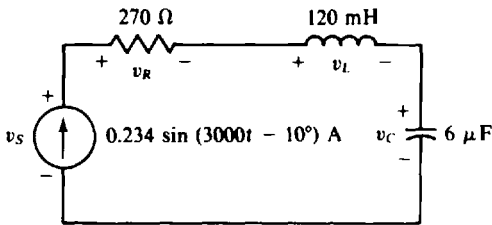

Fig. 11-5

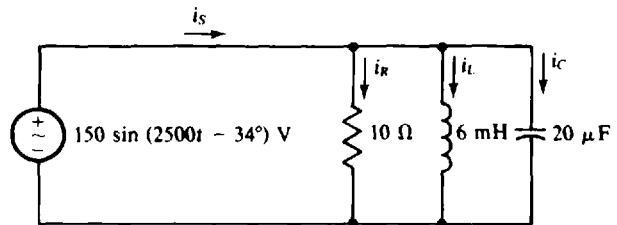

Fig. 11-6

11.18 Find i_s for the circuit shown in Fig. 11-6.

The current i_s can be determined from $i_s = i_R + i_L + i_C$ after these component currents are found. By Ohm's law,

$$i_R = \frac{150 \sin(2500t - 34^\circ)}{10} = 15 \sin(2500t - 34^\circ) \text{ A}$$

The inductor current i_L lags the voltage by 90° and has a peak value that is $1/\omega L = 1/(2500 \times 6 \times 10^{-3}) = 1/15$ times the peak value of the voltage:

$$i_L = \frac{150 \sin(2500t - 34^\circ - 90^\circ)}{15} = 10 \sin(2500t - 124^\circ) \text{ A}$$

The capacitor current i_C leads the voltage by 90° and has a peak value that is $\omega C = 2500(20 \times 10^{-6}) = 0.05$ times the peak value of the voltage:

$$i_C = 0.05(150) \sin(2500t - 34^\circ + 90^\circ) = 7.5 \sin(2500t + 56^\circ) \text{ A}$$

Phasors, which are conveniently based on peak values, can be used to find the sum sinusoid:

$$\mathbf{I}_S = \mathbf{I}_R + \mathbf{I}_L + \mathbf{I}_C = 15/\underline{-34^\circ} + 10/\underline{-124^\circ} + 7.5/\underline{56^\circ} = 15.2/\underline{-43.5^\circ} \text{ A} \rightarrow i_s = 15.2 \sin(2500t - 43.5^\circ) \text{ A}$$

- 11.19** If two currents have phasors of $10/0^\circ$ and $7/30^\circ$ mA, what is the angle and rms value of the current that is the sum of these currents? Solve by using a funicular diagram. Check the answer by using complex algebra.

Figure 11-7 shows the tail of the 7-mA phasor at the tip of the 10-mA phasor, as required for vector addition. The sum phasor, extending from the tail of the 10-mA phasor to the tip of the 7-mA phasor, has a length corresponding to approximately 16.5 mA and an angle of approximately 13° . In comparison, the result from complex algebra is

$$10/0^\circ + 7/30^\circ = 10 + 6.06 + j3.5 = 16.06 + j3.5 = 16.4/12.3^\circ \text{ mA}$$

which is, of course, considerably more accurate than the graphical result.

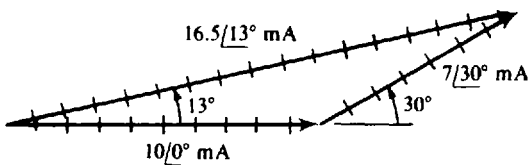

Fig. 11-7

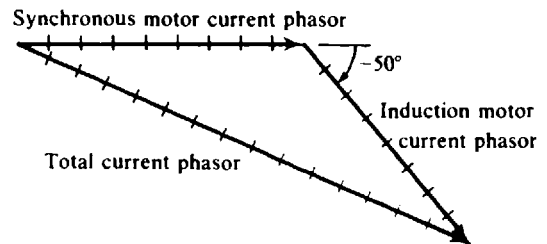

Fig. 11-8

- 11.20** A synchronous motor draws a 9-A current from a 240-V, 60-Hz source. A parallel induction motor draws 8 A. If the synchronous motor current leads the applied voltage by 20° , and if the induction motor current lags this voltage by 30° , what is the total current drawn from the source? Find this current graphically and algebraically.

The choice of the reference phasor - the one arranged horizontally at 0° - is somewhat arbitrary. The voltage phasor or either current phasor could be used. In fact, no phasor has to be at 0° , but it is usually convenient to have one at this angle. In Fig. 11-8 the synchronous motor current phasor is arbitrarily positioned horizontally, and the induction motor current phasor at its tip is positioned at an angle of -50° with it since there is a $20^\circ - (-30^\circ) = 50^\circ$ phase angle difference between the two currents. Also shown is the sum phasor, which has a measured length corresponding to 15.4 A. In comparison, from complex algebra,

$$\mathbf{I} = 9/0^\circ + 8/-50^\circ = 9 + 5.14 - j6.13 = 14.14 - j6.13 = 15.4/-23.4^\circ \text{ A}$$

and $\mathbf{I} = |\mathbf{I}| = |15.4/-23.4^\circ| = 15.4 \text{ A}$

in agreement with the graphical result to three significant digits. Usually, agreement to only two significant digits should be expected because of the comparative lack of accuracy with the graphical approach.

Supplementary Problems

- 11.21** Perform the following operations:

(a) $j6 - j7 + j4 - j8 + j9$ (b) $(j2)^2(-j3)(j7)(-j8)(j0.9)$ (c) $\frac{-j100}{5}$ (d) $\frac{8}{-j4}$

Ans. (a) $j4$, (b) -604.8 , (c) $-j20$, (d) $j2$

11.22 Perform the following operations and express the results in rectangular form:

(a) $(4.59 + j6.28) + (5.21 - j4.63)$

(b) $(8.21 + j4.31) - (4.92 - j6.23) - (-5.16 + j7.21)$

(c) $3 + j4 - 5 + j6 - 7 + j8 - 9 + j10 - 11$

Ans. (a) $9.8 + j1.65$, (b) $8.45 + j3.33$, (c) $-29 + j28$

11.23 Find the following products and express them in rectangular form:

(a) $(6 - j7)(4 + j2)$

(b) $(5 + j1)(-7 - j4)(-6 + j9)$

(c) $(-2 + j6)(-4 - j4)(-6 + j8)(7 + j3)$

Ans. (a) $38 - j16$, (b) $429 - j117$, (c) $-1504 + j2272$

11.24 Find the following products and express them in rectangular form:

(a) $(4 + j3)^2(4 - j3)^2$ (b) $(0.6 - j0.3)^2(-2 + j4)^3$

Ans. (a) 625 , (b) $18 - j36$

11.25 Evaluate $\begin{vmatrix} 6 - j8 & 2 - j3 \\ -4 + j2 & -5 + j9 \end{vmatrix}$.

Ans. $44 + j78$

11.26 Evaluate $\begin{vmatrix} 6 + j5 & -j2 & -4 \\ -j2 & 10 - j8 & -6 \\ -4 & -6 & 5 - j6 \end{vmatrix}$.

Ans. $156 - j762$

11.27 Evaluate $\begin{vmatrix} 10 - j2 & -2 + j1 & -3 - j4 \\ -2 + j1 & 9 - j8 & -6 + j2 \\ -3 - j4 & -6 + j2 & 12 - j4 \end{vmatrix}$.

Ans. $-65 - j1400$

11.28 Find the following quotients in rectangular form:

(a) $\frac{1}{0.1 - j0.4}$ (b) $\frac{1}{-0.4 + j0.5}$ (c) $\frac{7 - j2}{6 - j3}$

Ans. (a) $0.588 + j2.35$, (b) $-0.976 - j1.22$, (c) $1.07 + j0.2$

11.29 Convert each of the following to polar form:

(a) $8.1 + j11$ (c) $-33.4 + j14.7$ (e) $16.2 + j16.2$

(b) $16.3 - j12.2$ (d) $-12.7 - j17.3$ (f) $-19.1 + j19.1$

Ans. (a) $13.7/\underline{53.6^\circ}$, (b) $20.4/\underline{-36.8^\circ}$, (c) $36.5/\underline{156^\circ}$, (d) $21.5/\underline{-126^\circ}$, (e) $22.9/\underline{45^\circ}$, (f) $27/\underline{135^\circ}$

11.30 Convert each of the following to rectangular form:

(a) $11.8/\underline{51^\circ}$ (c) $15.8/\underline{215^\circ}$ (e) $-16.9/\underline{-36^\circ}$

(b) $13.7/\underline{142^\circ}$ (d) $27.4/\underline{-73^\circ}$ (f) $-24.1/\underline{-1200^\circ}$

Ans. (a) $7.43 + j9.17$, (b) $-10.8 + j8.43$, (c) $-12.9 - j9.06$, (d) $8.01 - j26.2$, (e) $-13.7 + j9.93$, (f) $12.1 + j20.9$

11.31 Perform the following operations and express the results in polar form:

$$(a) 6.31 - j8.23 + 7.14 \angle 23.1^\circ - 8.92 \angle -47.5^\circ$$

$$(b) 45.7 \angle -34.6^\circ - 68.9 \angle -76.3^\circ - 48.9 \angle 121^\circ$$

$$(c) -56.1 \angle -49.8^\circ + 73.1 \angle -74.2^\circ - 8 - j6$$

$$\text{Ans. } (a) 6.95 \angle 9.51^\circ, (b) 46.5 \angle -1.14^\circ, (c) 41.4 \angle -126^\circ$$

11.32 Find the following products in polar form:

$$(a) (5.21 \angle -36.1^\circ)(0.141 \angle 110^\circ)(-6.31 \angle -116^\circ)(1.72 \angle 210^\circ)$$

$$(b) (5 + j3)(-6 + j1)(0.23 \angle -17.1^\circ)$$

$$(c) (0.2 - j0.5)(1.4 - j0.72)(-2.3 + j1.3)(-1.62 - j1.13)$$

$$\text{Ans. } (a) 7.97 \angle -12.1^\circ, (b) -8.16 \angle 4.4^\circ, (c) 4.42 \angle -90^\circ$$

11.33 Find the following quotients in polar form:

$$(a) \frac{173 \angle 62.1^\circ}{38.9 \angle -14.1^\circ} \quad (b) \frac{4.13 - j3.21}{-7.12 \angle 23.1^\circ} \quad (c) \frac{26.1 \angle 37.3^\circ}{-4.91 - j5.32}$$

$$\text{Ans. } (a) 4.45 \angle 76.2^\circ, (b) -0.735 \angle -61^\circ, (c) -3.61 \angle -9.5^\circ$$

11.34 Find the following quotients in polar form:

$$(a) \frac{(6.21 - j9.23)(-7.21 + j3.62)(21.3 \angle 35.1^\circ)}{(-14.1 + j6.82)(6.97 \angle 68^\circ)(10.2 \angle -41^\circ)}$$

$$(b) \frac{(6 \angle -45^\circ)(3 - j8) - (-7 + j4)(8 - j4)(3.62 \angle 70^\circ)}{(-4.1 + j2)(3.4 + j6.1)(11 \angle -27^\circ)}$$

$$\text{Ans. } (a) 1.72 \angle -48.8^\circ, (b) -0.665 \angle -4.14^\circ$$

11.35 Find the following quotient in polar form:

$$\frac{(-6.29 \angle -70.1^\circ)^4 (8.4 \angle 17^\circ)^3 (8.1 \angle 44^\circ)^{1^2}}{(13.4 \angle -16^\circ)^2 (-62.9 \angle -107^\circ)(0.729 \angle 93^\circ)^{1^3}}$$

$$\text{Ans. } 260 \angle 80.6^\circ$$

11.36 Find the corresponding phasor voltages and currents of the following in polar form:

$$(a) v = \sqrt{2}(42.1) \sin(400t - 30^\circ) \text{ V} \quad (d) i = -38.1 \cos(754t - 72^\circ) \text{ A}$$

$$(b) i = \sqrt{2}(36.9) \sin(6000t + 72^\circ) \text{ A} \quad (e) v = -86.4 \cos(672t + 34^\circ) \text{ V}$$

$$(c) v = -64.3 \sin(377t - 34^\circ) \text{ V}$$

$$\text{Ans. } (a) \mathbf{V} = 42.1 \angle -30^\circ \text{ V}, (b) \mathbf{I} = 36.9 \angle 72^\circ \text{ A}, (c) \mathbf{V} = -45.5 \angle -34^\circ \text{ V}, (d) \mathbf{I} = -26.9 \angle 18^\circ \text{ A}, (e) \mathbf{V} = 61.1 \angle -56^\circ \text{ V}$$

11.37 Find the voltages and currents corresponding to the following phasor voltages and currents (each sinusoid has a radian frequency of 754 rad/s):

$$(a) \mathbf{V} = 15.1 \angle 62^\circ \text{ V} \quad (c) \mathbf{V} = -14.3 \angle -69.7^\circ \text{ V} \quad (e) \mathbf{V} = -7 - j8 \text{ V}$$

$$(b) \mathbf{I} = 9.62 \angle -31^\circ \text{ A} \quad (d) \mathbf{I} = 4 - j6 \text{ A} \quad (f) \mathbf{I} = -8.96 + j7.61 \text{ A}$$

$$\text{Ans. } (a) v = 21.4 \sin(754t + 62^\circ) \text{ V} \quad (d) i = 10.2 \sin(754t - 56.3^\circ) \text{ A}$$

$$(b) i = 13.6 \sin(754t - 31^\circ) \text{ A} \quad (e) v = -15 \sin(754t + 48.8^\circ) \text{ V}$$

$$(c) v = -20.2 \sin(754t - 69.7^\circ) \text{ V} \quad (f) i = -16.6 \sin(754t - 40.3^\circ) \text{ A}$$

11.38 Find a single sinusoid that is the equivalent of each of the following:

(a) $7.21 \sin \omega t + 11.2 \cos \omega t$

(b) $-8.63 \sin 377t - 4.19 \cos 377t$

(c) $4.12 \sin (64t - 10^\circ) - 6.23 \sin (64t - 35^\circ) + 7.26 \cos (64t - 35^\circ) - 8.92 \cos (64t + 17^\circ)$

Ans. (a) $13.3 \sin (\omega t + 57.2^\circ)$, (b) $-9.59 \sin (377t + 25.9^\circ)$, (c) $5.73 \sin (64t + 2.75^\circ)$

11.39 In Fig. 11-9, find i_1 if $i_2 = 14.6 \sin (377t - 15^\circ)$ mA, $i_3 = 21.3 \sin (377t + 30^\circ)$ mA, and $i_4 = 13.7 \cos (377t + 15^\circ)$ mA.

Ans. $i_1 = -27.7 \cos (377t + 88.3^\circ)$ mA

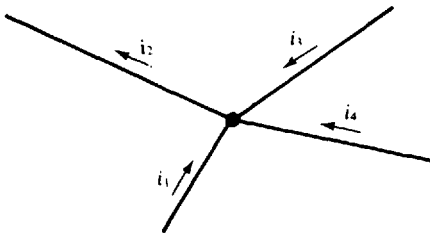

Fig. 11-9

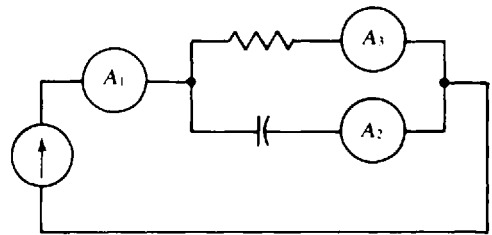

Fig. 11-10

11.40 In the circuit shown in Fig. 11-10, ammeters A_1 and A_2 have readings of 4 and 3 A, respectively. What is the reading of ammeter A_3 ?

Ans. 2.65 A

11.41 A current $i = 0.621 \sin (400t + 30^\circ)$ mA flows through a 3.3-k Ω resistor in series with a 0.5- μ F capacitor. Find the voltage across the series combination. Of course, as always, assume associated references when, as here, there is no statement to the contrary.

Ans. $v = 3.72 \sin (400t - 26.6^\circ)$ V

11.42 A voltage $v = 240 \sin (400t + 10^\circ)$ V is across a 680- Ω resistor in parallel with a 1-H inductor. Find the current flowing into this parallel combination.

Ans. $i = 0.696 \sin (400t - 49.5^\circ)$ A

11.43 A current $i = 0.248 \cos (377t - 15^\circ)$ A flows through the series combination of a 91- Ω resistor, a 120-mH inductor, and a 20- μ F capacitor. Find the voltage across the series combination.

Ans. $v = 31.3 \sin (377t + 31.2^\circ)$ V

11.44 The voltage $v = 120 \sin (1000t + 20^\circ)$ V is across the parallel combination of a 10-k Ω resistor, a 100-mH inductor, and a 10- μ F capacitor. Find the total current i_T flowing into the parallel combination. Also, find the inductor current i_L and compare peak values of i_L and i_T .

Ans. $i_T = 0.012 \sin (1000t + 20^\circ)$ A and $i_L = 1.2 \sin (1000t - 70^\circ)$ A. The inductor current peak is 100 times the input current peak.

Basic AC Circuit Analysis, Impedance, and Admittance

INTRODUCTION

In the analysis of an ac circuit, voltage and current phasors are used with resistances and reactances in much the same way that voltages and currents are used with resistances in the analysis of a dc circuit. The original ac circuit, called a *time-domain circuit*, is transformed into a *phasor-domain circuit* that has phasors instead of sinusoidal voltages and currents, and that has reactances instead of inductances and capacitances. Resistances remain unchanged. The phasor-domain circuit is the circuit that is actually analyzed. It has the advantage that the resistances and reactances have the same ohm unit and so can be combined similarly to the way that resistances can be combined in a dc circuit analysis. Also, the analysis of the phasor-domain circuit requires no calculus, but only complex algebra. Finally, all the dc circuit analysis concepts for finding voltages and currents apply to the analysis of a phasor-domain circuit, but, of course, complex numbers are used instead of real numbers.

PHASOR-DOMAIN CIRCUIT ELEMENTS

The transformation of a time-domain circuit into a phasor-domain circuit requires relations between the voltage and current phasors for resistors, inductors, and capacitors. First, consider obtaining this relation for a resistor of R ohms. For a current $i = I_m \sin(\omega t + \theta)$, the resistor voltage is, of course, $v = RI_m \sin(\omega t + \theta)$, with associated references assumed. The corresponding phasors are

$$\mathbf{I} = \frac{I_m}{\sqrt{2}} \angle \theta \quad \text{A} \quad \text{and} \quad \mathbf{V} = \frac{RI_m}{\sqrt{2}} \angle \theta \quad \text{V}$$

Dividing the voltage equation by the current equation eliminates I_m , θ , and $\sqrt{2}$ and produces a relation between the voltage and current phasors:

$$\frac{\mathbf{V}}{\mathbf{I}} = \frac{(I_m R \sqrt{2}) \angle \theta}{(I_m \sqrt{2}) \angle \theta} = R$$

This result shows that the resistance R of a resistor relates the resistor voltage and current phasors in the same way that it relates the resistor voltage and current ($R = v/i$). Because of this similarity, the relation $\mathbf{V}/\mathbf{I} = R$ can be represented in a phasor-domain circuit in the same way that $v/i = R$ is represented in the original time-domain circuit. Figure 12-1 shows this.

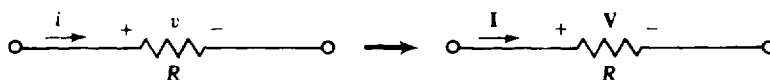

Fig. 12-1

Next, consider an inductor of L henries. As shown in Chap. 10, for a current $i = I_m \sin(\omega t + \theta)$, the inductor voltage is $v = \omega LI_m \cos(\omega t + \theta) = \omega LI_m \sin(\omega t + \theta + 90^\circ)$. The corresponding phasors are

$$\mathbf{I} = \frac{I_m}{\sqrt{2}} \angle \theta \quad \text{A} \quad \text{and} \quad \mathbf{V} = \frac{\omega LI_m}{\sqrt{2}} \angle \theta + 90^\circ \quad \text{V}$$

Dividing the voltage equation by the current equation results in a phasor relation of

$$\frac{\mathbf{V}}{\mathbf{I}} = \frac{(\omega L I_m / \sqrt{2}) / \theta + 90}{(I_m / \sqrt{2}) / \theta} = \omega L / 90$$

This result of $\omega L / 90^\circ$ in polar form is $j\omega L$ in rectangular form. Since ωL is the inductive reactance X_L , as defined in Chap. 10, then

$$\frac{\mathbf{V}}{\mathbf{I}} = j\omega L = jX_L$$

Note that $j\omega L$ relates the inductor voltage and current phasors in the same way that R relates the resistor voltage and current phasors. Consequently, $j\omega L$ has a similar current-limiting action and the same ohm unit. In addition, because of its $j1$ multiplier, it produces a phase shift of 90° ($j1 = 1/90^\circ$).

From the resistor discussion and the similarity of $\mathbf{V}/\mathbf{I} = R$ and $\mathbf{V}/\mathbf{I} = j\omega L$, the time-domain circuit to phasor-domain circuit transformation for an inductor, as shown in Fig. 12-2, should be apparent. The usual inductor circuit symbol is used in the phasor-domain circuit, but it is associated with $j\omega L$ ohms instead of with the L henries of the original time-domain circuit. The inductor voltage and current are transformed, of course, into corresponding phasors.



Fig. 12-2

The same approach can be used for a capacitor. For a voltage $v = V_m \sin(\omega t + \theta)$, a capacitor of C farads has a current of $i = \omega C V_m \sin(\omega t + \theta + 90^\circ)$. The corresponding phasors are

$$\mathbf{V} = \frac{V_m}{\sqrt{2}} / \theta \quad \text{V} \quad \text{and} \quad \mathbf{I} = \frac{\omega C V_m}{\sqrt{2}} / \theta + 90^\circ \quad \text{A}$$

and

$$\frac{\mathbf{V}}{\mathbf{I}} = \frac{(V_m / \sqrt{2}) / \theta}{(\omega C V_m / \sqrt{2}) / \theta + 90^\circ} = \frac{1}{\omega C / 90^\circ} = \frac{1}{j\omega C} = \frac{-j1}{\omega C}$$

As defined in Chap. 10, $-1/\omega C$ is the reactance X_C of a capacitor. Therefore,

$$\frac{\mathbf{V}}{\mathbf{I}} = \frac{-j1}{\omega C} = jX_C$$

(Remember that many circuits books have capacitive reactance defined as $X_C = 1/\omega C$, in which case $\mathbf{V}/\mathbf{I} = -jX_C$.) The $-j1/\omega C$ quantity has a current-limiting action similar to that of a resistance. In addition, the $-j1$ multiplier produces a -90° phase shift.

Figure 12-3 shows the time-domain circuit to phasor-domain circuit transformation for a capacitor. In the phasor-domain circuit the conventional capacitor circuit symbol is used, but it is associated with $-j1/\omega C$ ohms instead of with the C farads of the original time-domain circuit.

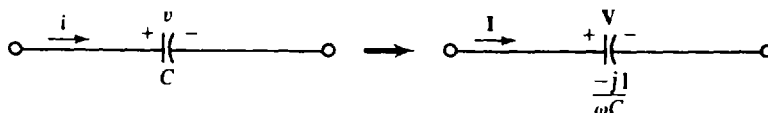

Fig. 12-3

AC SERIES CIRCUIT ANALYSIS

A method for analyzing a series ac circuit can be understood from a simple example. Suppose that the sinusoidal current i is to be found in the series circuit shown in Fig. 12-4a, in which the source has a radian frequency of $\omega = 4$ rad/s. The first step is to draw the corresponding phasor-domain circuit shown in Fig. 12-4b, in which the current and voltages are replaced by corresponding phasors, the inductance is replaced by

$$j\omega L = j4(2) = j8 \Omega$$

and the capacitance is replaced by

$$\frac{-j1}{\omega C} = \frac{-j1}{4(1/16)} = -j4 \Omega$$

The resistance, of course, is not changed.

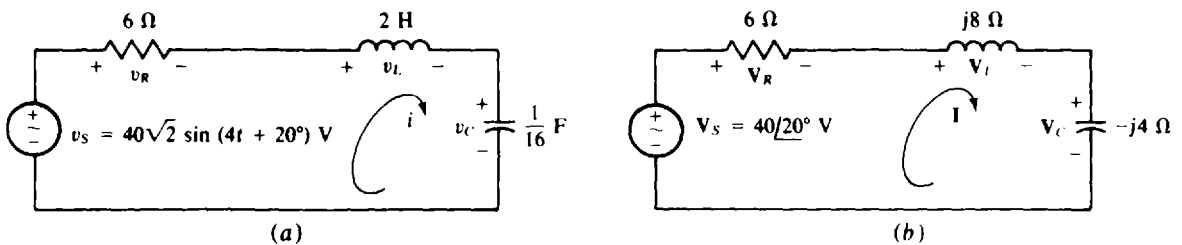

Fig. 12-4

The next step is to apply KVL to this phasor-domain circuit. Although it is not obvious, KVL applies to voltage phasors as well as to voltages because it applies to the sinusoidal voltages, and these sinusoids can be summed using phasors. (For similar reasons, KCL applies to the current phasors of phasor-domain circuits.) The result of applying KVL is

$$\mathbf{V}_S = \mathbf{V}_R + \mathbf{V}_L + \mathbf{V}_C$$

The third step is to substitute for the \mathbf{V} 's using $\mathbf{V}_S = 40/20^\circ$, $\mathbf{V}_R = 6\mathbf{I}$, $\mathbf{V}_L = j8\mathbf{I}$, and $\mathbf{V}_C = -j4\mathbf{I}$. With these substitutions the KVL equation becomes

$$40/20^\circ = 6\mathbf{I} + j8\mathbf{I} - j4\mathbf{I} = (6 + j4)\mathbf{I}$$

from which

$$\mathbf{I} = \frac{40/20^\circ}{6 + j4} = \frac{40/20^\circ}{7.211/33.7^\circ} = 5.547/-13.7^\circ \text{ A}$$

and

$$i = 5.547\sqrt{2} \sin(4t - 13.7^\circ) = 7.84 \sin(4t - 13.7^\circ) \text{ A}$$

IMPEDANCE

The KVL analysis method of the last section requires much more work than is necessary. Some of the initial steps can be eliminated by using *impedance*. Impedance has the quantity symbol \mathbf{Z} and the unit ohm (Ω). For a two-terminal circuit with an input voltage phasor \mathbf{V} and an input current phasor \mathbf{I} , as shown in Fig. 12-5, the impedance \mathbf{Z} of the circuit is defined as

$$\mathbf{Z} = \frac{\mathbf{V}}{\mathbf{I}}$$

For this impedance to exist, the circuit cannot have any independent sources, although it can have any number of dependent sources. This impedance is often called the *total* or *equivalent impedance*. It

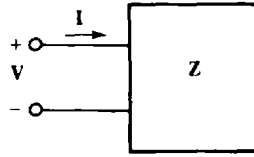

Fig. 12-5

is also called the *input impedance*, especially for a circuit that has dependent sources or transformers. (Transformers will be discussed in Chap. 16.)

In general, and not just for series circuits,

$$\mathbf{Z} = R + jX$$

in which R , the real part, is the *resistance* and X , the imaginary part, is the *reactance* of the impedance. For the series phasor-domain circuit shown in Fig. 12-4b, $R = 6\ \Omega$ and $X = 8 - 4 = 4\ \Omega$. For this circuit, the resistance R depends only on the resistance of the resistor, and the reactance X depends only on the reactances of the inductor and capacitor. But for a more complex circuit, R and X are usually both dependent on the individual resistances and reactances.

Being a complex quantity, impedance can be expressed in polar form. From complex algebra,

$$\mathbf{Z} = R + jX = \sqrt{R^2 + X^2} \angle \tan^{-1}(X/R)$$

in which $\sqrt{R^2 + X^2} = |\mathbf{Z}| = Z$ is the magnitude of impedance and $\tan^{-1}(X/R)$ is the angle of impedance.

As should be evident from $\mathbf{Z} = \mathbf{V}/\mathbf{I}$, the impedance angle is the angle by which the input voltage *leads* the input current, provided that this angle is positive. If it is negative, then the current leads the voltage. A circuit with a positive impedance angle is sometimes called an *inductive circuit* because the inductive reactances dominate the capacitive reactances to cause the input current to lag the input voltage. Similarly, a circuit that has a negative impedance angle is sometimes called a *capacitive circuit*.

Because impedances relate to voltage and current phasors in the same way that resistances relate to dc voltages and currents, it follows that impedances can be combined in the same way as resistances. Consequently, the total impedance \mathbf{Z}_T of electrical components connected in series equals the sum of the impedances of the individual components:

$$\mathbf{Z}_T = \mathbf{Z}_1 + \mathbf{Z}_2 + \mathbf{Z}_3 + \cdots + \mathbf{Z}_N$$

And, for two parallel components with impedances \mathbf{Z}_1 and \mathbf{Z}_2 ,

$$\mathbf{Z}_T = \frac{\mathbf{Z}_1 \mathbf{Z}_2}{\mathbf{Z}_1 + \mathbf{Z}_2}$$

Often, the T subscript in \mathbf{Z}_T is omitted.

The total impedance of an ac circuit is used in the same way as the total resistance of a dc circuit. For example, for the circuit shown in Fig. 12-4a, the first step after drawing the phasor-domain circuit illustrated in Fig. 12-4b is to find the impedance of the circuit at the terminals of the source. This being a series circuit, the total impedance is equal to the sum of the individual impedances:

$$\mathbf{Z} = 6 + j(8 - 4) = 6 + j4 = 7.211 \angle 33.7^\circ\ \Omega$$

Then, this is divided into the voltage phasor of the source to obtain the current phasor:

$$\mathbf{I} = \frac{\mathbf{V}}{\mathbf{Z}} = \frac{40 \angle 20^\circ}{7.211 \angle 33.7^\circ} = 5.547 \angle -13.7^\circ\ \text{A}$$

And, of course, the current i can be found from its phasor \mathbf{I} , as has been done.

An *impedance diagram* is an aid to understanding impedance. This diagram is constructed on an impedance plane which, as illustrated in Fig. 12-6, has a horizontal resistance axis designated by R and

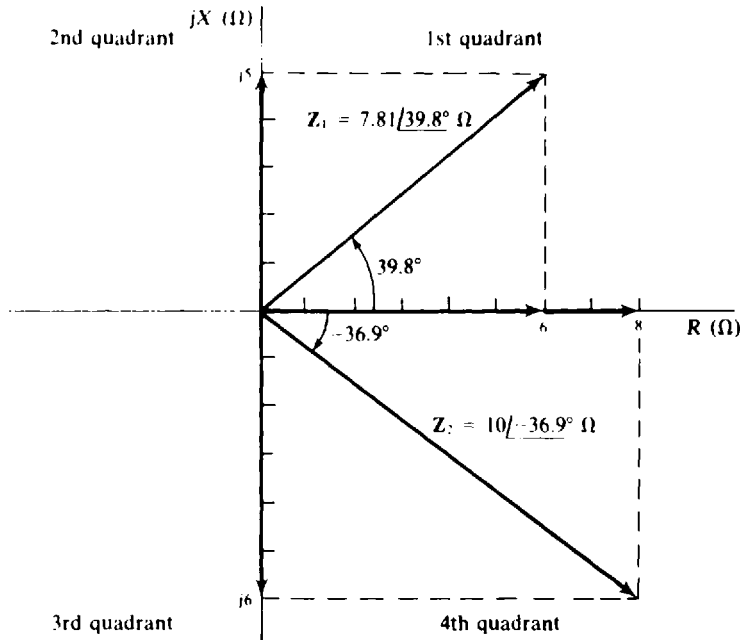

Fig. 12-6

a vertical reactance axis designated by jX . Both axes have the same scale. Shown is a diagram of $Z_1 = 6 + j5 = 7.81/39.8^\circ \Omega$ for an inductive circuit and $Z_2 = 8 - j6 = 10/-36.9^\circ \Omega$ for a capacitive circuit. An inductive circuit has an impedance diagram in the first quadrant and a capacitive circuit has one in the fourth quadrant. For a diagram to be in either the second or third quadrant, a circuit must have a negative resistance, which may occur if a circuit contains dependent sources.

An *impedance triangle* is often a more convenient graphical representation. The triangle contains vectors corresponding to R , jX , and Z , with the vector for jX drawn at the end of the R vector and the vector for Z drawn as the sum of these two vectors, as in Fig. 12-7a. Figure 12-7b shows an impedance triangle for $Z = 6 + j8 = 10/53.1^\circ \Omega$ and Fig. 12-7c one for $Z = 6 - j8 = 10/-53.1^\circ \Omega$.

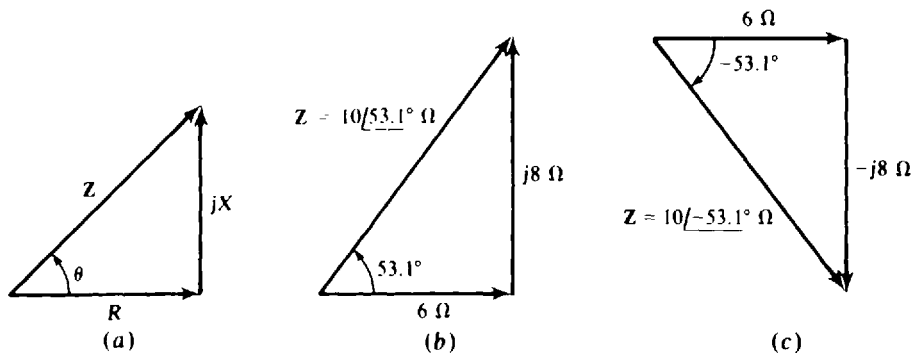

Fig. 12-7

VOLTAGE DIVISION

The voltage division or divider rule for ac circuits should be apparent from this rule for dc circuits. Of course, voltage phasors must be used instead of voltages and impedances instead of resistances. So, for a series circuit energized by an applied voltage with phasor V_S , the voltage phasor V_X across a

component with impedance Z_x is

$$V_x = \frac{Z_x}{Z_T} V_S$$

in which Z_T is the sum of the impedances. A negative sign must be included if V_x and V_S do not have opposing polarities.

AC PARALLEL CIRCUIT ANALYSIS

A method for analyzing a parallel ac circuit can be illustrated by a simple example. Suppose that the sinusoidal voltage v is to be found in the parallel circuit shown in Fig. 12-8a. With the techniques presented so far, the first step in finding v is to draw the corresponding phasor-domain circuit shown in Fig. 12-8b, using the source frequency of 5000 rad/s. The next step is to apply KCL to this circuit:

$$I_S = I_R + I_L + I_C$$

The third step is to substitute for the I 's, using $I_S = 10\angle 0^\circ$, $I_R = V/1000$, $I_L = V/j2500$, and $I_C = V/(-j1000)$. With these substitutions, the equation becomes

$$10\angle 0^\circ = \frac{V}{1000} + \frac{V}{j2500} + \frac{V}{-j1000}$$

which simplifies to

$$10\angle 0^\circ = (0.001 + j0.0006)V$$

from which

$$V = \frac{10\angle 0^\circ}{0.001 + j0.0006} = \frac{10\angle 0^\circ}{0.001166\angle 31^\circ} \quad V = 8.6\angle -31^\circ \text{ kV}$$

The corresponding voltage is

$$v = 8.6\sqrt{2} \sin(5000t - 31^\circ) = 12 \sin(5000t - 31^\circ) \text{ kV}$$

Since this voltage lags the input current, the circuit is capacitive. This is the result of the capacitive reactance being smaller than the inductive reactance—directly opposite the effect for a series circuit.

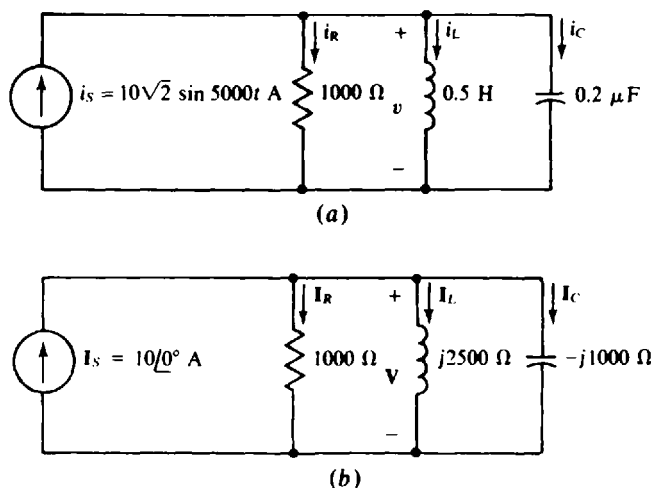

Fig. 12-8

ADMITTANCE

The analysis method of the last section can be improved upon by using *admittance*, which has the quantity symbol \mathbf{Y} and the unit siemens (S). By definition, admittance is the reciprocal of impedance:

$$\mathbf{Y} = \frac{1}{\mathbf{Z}}$$

From this it follows that

$$\mathbf{I} = \mathbf{Y}\mathbf{V}$$

Also, it follows that the admittance of a resistor is $\mathbf{Y} = 1/R = G$, that of an inductor is $\mathbf{Y} = 1/j\omega L = -j1/\omega L$, and that of a capacitor is $\mathbf{Y} = 1/(-j1/\omega C) = j\omega C$.

Being the reciprocal of impedance, the admittance of an ac circuit corresponds to the conductance of a dc resistive circuit. Consequently, admittances of *parallel* components can be added:

$$\mathbf{Y}_T = \mathbf{Y}_1 + \mathbf{Y}_2 + \mathbf{Y}_3 + \cdots + \mathbf{Y}_N$$

In general, and not just for parallel circuits,

$$\mathbf{Y} = G + jB$$

in which G , the real part, is the *conductance* and B , the imaginary part, is the *susceptance* of the admittance. For the parallel phasor-domain circuit shown in Fig. 12-8b,

$$\mathbf{Y} = \frac{1}{1000} + \frac{1}{j2500} + \frac{1}{-j1000} = 0.001 + j0.0006 \text{ S}$$

from which $G = 0.001 \text{ S}$ and $B = 0.0006 \text{ S}$. For this simple parallel circuit, the conductance G depends only on the conductance of the resistor, and the susceptance B depends only on the susceptances of the inductor and capacitor. But for a more complex circuit, both G and B usually depend on the individual conductances and susceptances.

Being a complex quantity, admittance can be expressed in polar form. From complex algebra,

$$\mathbf{Y} = G + jB = \sqrt{G^2 + B^2} / \tan^{-1}(B/G)$$

in which $\sqrt{G^2 + B^2} = |\mathbf{Y}| = Y$ is the magnitude and $\tan^{-1}(B/G)$ is the angle of admittance.

Since admittance is the reciprocal of impedance, the angle of an admittance is the negative of the angle for the corresponding impedance. Consequently, an admittance angle is positive for a capacitive circuit and negative for an inductive circuit. Also, B , the susceptance, has these same signs.

The total admittance of an ac circuit is used in the same way as the total conductance of a dc circuit. To illustrate, for the circuit shown in Fig. 12-8a, the first step after drawing the phasor-domain circuit illustrated in Fig. 12-8b is to find the admittance of the circuit at the terminals of the source. As has been found, $\mathbf{Y} = 0.001 + j0.0006 = 0.001 \angle 31^\circ \text{ S}$. Then, this is divided into the current phasor to obtain the voltage phasor:

$$\mathbf{V} = \frac{\mathbf{I}}{\mathbf{Y}} = \frac{10 \angle 0^\circ}{0.001 \angle 31^\circ} \text{ V} = 8.6 \angle -31^\circ \text{ kV}$$

Finally, the voltage v can be determined from its phasor \mathbf{V} , as has been done.

As should be expected from the discussion of an impedance diagram, there is an *admittance diagram* that can be constructed on an admittance plane that has a horizontal conductance axis G and a vertical susceptance axis jB . There is also an *admittance triangle* that is used similarly to the impedance triangle.

CURRENT DIVISION

Current division applies to ac phasor-domain circuits in the same way as to dc resistive circuits. So, if a parallel phasor-domain circuit has a current phasor \mathbf{I}_S directed into it, the current phasor \mathbf{I}_X for a branch that has an admittance \mathbf{Y}_X is

$$\mathbf{I}_X = \frac{\mathbf{Y}_X}{\mathbf{Y}_T} \mathbf{I}_S$$

in which \mathbf{Y}_T is the sum of the admittances. A negative sign must be included if \mathbf{I}_X and \mathbf{I}_S do not have opposite reference directions into one of the nodes. For the special case of two parallel branches with impedances \mathbf{Z}_1 and \mathbf{Z}_2 , this formula reduces to

$$\mathbf{I}_1 = \frac{\mathbf{Z}_2}{\mathbf{Z}_1 + \mathbf{Z}_2} \mathbf{I}_S$$

in which \mathbf{I}_1 is the current phasor for the \mathbf{Z}_1 branch.

For convenience, from this point on the word “phasor” in voltage phasor and current phasor will often be omitted. That is, the V's and I's will often be referred to as voltages and currents, respectively, as is common practice.

Solved Problems

- 12.1** Find the total impedance in polar form of a 0.5-H inductor and a series 20- Ω resistor at (a) 0 Hz, (b) 10 Hz, and (c) 10 kHz.

The total impedance is $\mathbf{Z} = R + j\omega L = R + j2\pi fL$.

- (a) For $f = 0$ Hz,

$$\mathbf{Z} = 20 + 2\pi(0)(0.5) = 20 = 20/\underline{0^\circ} \Omega$$

The impedance is purely resistive because 0 Hz corresponds to dc, and an inductor is a short circuit to dc.

- (b) For $f = 10$ Hz,

$$\mathbf{Z} = 20 + j2\pi(10)(0.5) = 20 + j31.4 = 37.2/\underline{57.5^\circ} \Omega$$

- (c) For $f = 10$ kHz,

$$\mathbf{Z} = 20 + j2\pi(10^4)(0.5) = 20 + j3.14 \times 10^4 \Omega = 31.4/\underline{89.96^\circ} \text{ k}\Omega$$

At 10 kHz the reactance is so much larger than the resistance that the resistance is negligible for most purposes.

- 12.2** A 200- Ω resistor, a 150-mH inductor, and a 2- μF capacitor are in series. Find the total impedance in polar form at 400 Hz. Also, draw the impedance diagram and the impedance triangle.

The total impedance is

$$\begin{aligned} \mathbf{Z} &= R + j2\pi fL + \frac{-j1}{2\pi fC} = 200 + j2\pi(400)(150 \times 10^{-3}) + \frac{-j1}{2\pi(400)(2 \times 10^{-6})} \\ &= 200 + j377 - j199 = 200 + j178 = 268/\underline{41.7^\circ} \Omega \end{aligned}$$

The impedance diagram is shown in Fig. 12-9a and the impedance triangle is shown in Fig. 12-9b. In the impedance diagram, the end point for the \mathbf{Z} arrow is found by starting at the origin and moving up the

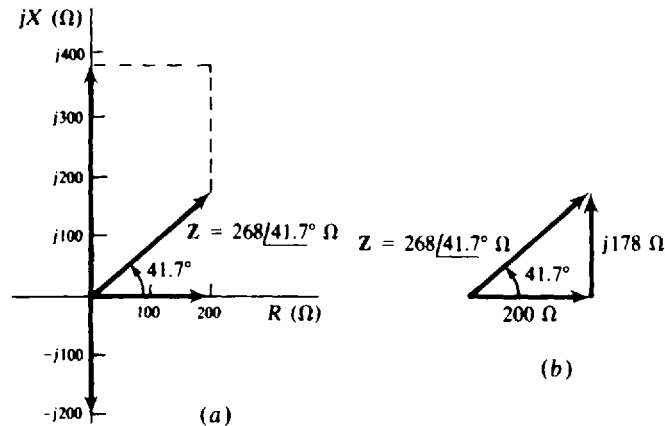

Fig. 12-9

vertical axis to $j377 \Omega$ (jX_L), then moving horizontally right to over 200Ω (R), and finally moving vertically down by 199Ω , the magnitude of the capacitive reactance ($|X_C|$). The impedance triangle construction is obvious from the calculated $R = 200 \Omega$ and $X = 178 \Omega$.

- 12.3** A $2000\text{-}\Omega$ resistor, a 1-H inductor, and a $0.01\text{-}\mu\text{F}$ capacitor are in series. Find the total impedance in polar form at (a) 5 krad/s , (b) 10 krad/s , and (c) 20 krad/s .

The formula for the total impedance is $Z = R + j\omega L - j1/\omega C$. So,

$$(a) \quad Z = 2000 + j5000(1) - \frac{j1}{5000(10^{-8})} = 2000 - j15\,000 \Omega = 15.1\angle-82.4 \text{ k}\Omega$$

$$(b) \quad Z = 2000 + j10\,000(1) - \frac{j1}{10\,000(10^{-8})} = 2000 \Omega = 2\angle0^\circ \text{ k}\Omega$$

$$(c) \quad Z = 2000 + j20\,000(1) - \frac{j1}{20\,000(10^{-8})} = 2000 + j15\,000 \Omega = 15.1\angle82.4 \text{ k}\Omega$$

Notice that for $\omega = 10 \text{ krad/s}$ in part (b), the impedance is purely resistive because the inductive and capacitive terms cancel. This is the *resonant radian frequency* of the circuit. For lower frequencies, the circuit is capacitive, as is verified in part (a). For higher frequencies, the circuit is inductive, as is verified in part (c).

- 12.4** A coil energized by 120 V at 60 Hz draws a 2-A current that lags the applied voltage by 40° . What are the coil resistance and inductance?

The magnitude of the impedance can be found by dividing the rms voltage by the rms current: $Z = 120/2 = 60 \Omega$. The angle of the impedance is the 40° angle by which the voltage leads the current. Consequently, $Z = 60\angle40^\circ = 46 + j38.6 \Omega$. From the real part, the resistance of the coil is 46Ω , and from the imaginary part, the reactance is 38.6Ω . Since ωL is the reactance, and $\omega = 2\pi(60) = 377 \text{ rad/s}$, the inductance is $L = 38.6/377 = 0.102 \text{ H}$.

- 12.5** A load has a voltage of $V = 120\angle30^\circ \text{ V}$ and a current of $I = 30\angle50^\circ \text{ A}$ at a frequency of 400 Hz . Find the two-element series circuit that the load could be. Assume associated references, of course.

The impedance is

$$Z = \frac{V}{I} = \frac{120\angle30^\circ}{30\angle50^\circ} = 4\angle-20^\circ = 3.76 - j1.37 \Omega$$

Because the imaginary part is negative, the circuit is capacitive, which means that the two series elements are a resistor and a capacitor. The real part is the resistance of the resistor: $R = 3.76 \Omega$. The imaginary part is the reactance of the capacitor, $-1/\omega C = -1.37$, from which

$$C = \frac{1}{1.37\omega} = \frac{1}{1.37(2\pi)(400)} \text{ F} = 291 \mu\text{F}$$

12.6 A $20\text{-}\Omega$ resistor is in series with a $0.1\text{-}\mu\text{F}$ capacitor. At what radian frequency are the circuit voltage and current out of phase by 40° ?

A good approach is to find the reactance from the impedance angle and the resistance, and then find the radian frequency from the reactance and the capacitance. The impedance angle has a magnitude of 40° because this is the phase angle difference between the voltage and the current. Also, the angle is negative because this is a capacitive circuit. So, $\theta = -40^\circ$. As should be apparent from the impedance triangle shown in Fig. 12-7a, and also from the complex algebra presentation, reactance and resistance are related by the tangent of the impedance angle: $X = R \tan \theta$. Here, $X_C = 20 \tan(-40^\circ) = -16.8 \Omega$. Finally, from $X_C = -1/\omega C$,

$$\omega = \frac{-1}{CX_C} = \frac{-1}{10^{-7}(-16.8)} \text{ rad/s} = 0.596 \text{ Mrad/s}$$

12.7 A 200-mH inductor and a resistor in series draw 0.6 A when 120 V at 100 Hz is applied. Find the impedance in polar form.

The magnitude of the impedance can be found by dividing the voltage by the current: $Z = 120/0.6 = 200 \Omega$. The angle of the impedance is $\theta = \sin^{-1}(X_L/Z)$, as is evident from the impedance triangle shown in Fig. 12-7a. Here,

$$\frac{X_L}{Z} = \frac{2\pi(100)(0.2)}{200} = 0.2\pi \quad \text{and so} \quad \theta = \sin^{-1} 0.2\pi = 38.9^\circ$$

The impedance is $Z = 200/38.9^\circ \Omega$.

12.8 What capacitor in series with a $750\text{-}\Omega$ resistor limits the current to 0.2 A when 240 V at 400 Hz is applied?

When the capacitor is in the circuit, the impedance has a magnitude of $Z = V/I = 240/0.2 = 1200 \Omega$. This is related to the resistance and reactance by $Z = \sqrt{R^2 + X^2}$. If both sides are squared and X solved for, the result is

$$X^2 = Z^2 - R^2 \rightarrow X = \pm \sqrt{Z^2 - R^2}$$

The negative sign must be selected because the circuit is capacitive and therefore has a negative reactance. Substituting for Z and R gives

$$X = -\sqrt{Z^2 - R^2} = -\sqrt{1200^2 - 750^2} = -937 \Omega$$

Finally, since $X = -1/\omega C$,

$$C = \frac{-1}{\omega X} = \frac{-1}{2\pi(400)(-937)} \text{ F} = 0.425 \mu\text{F}$$

Incidentally, another way of finding X is from the impedance magnitude times the sine of the impedance angle:

$$X = Z \sin\left(-\cos^{-1}\left(\frac{R}{Z}\right)\right) = 1200 \sin\left(-\cos^{-1}\left(\frac{750}{1200}\right)\right) = -937 \Omega$$

- 12.9** A capacitor is in series with a coil that has 1.5 H of inductance and $5\ \Omega$ of resistance. Find the capacitance that makes the combination purely resistive at 60 Hz.

For the circuit to be purely resistive, the reactances must add to zero. And since the reactance of the inductor is $2\pi(60)(1.5) = 565\ \Omega$, the reactance of the capacitor must be $-565\ \Omega$. From $X_C = -1/\omega C$,

$$C = -\frac{1}{\omega X_C} = \frac{-1}{2\pi(60)(-565)}\ \text{F} = 4.69\ \mu\text{F}$$

- 12.10** Three circuit elements in series draw a current of $10 \sin(400t + 70^\circ)\ \text{A}$ in response to an applied voltage of $50 \sin(400t + 15^\circ)\ \text{V}$. If one element is a 16-mH inductor, what are the two other elements?

The unknown elements can be found from the impedance. It has a magnitude that is equal to the voltage peak divided by the current peak: $Z = 50/10 = 5\ \Omega$, and an angle that is the voltage phase angle minus the current phase angle: $\theta = 15^\circ - 70^\circ = -55^\circ$. Therefore, the impedance is $Z = 5\angle -55^\circ = 2.87 - j4.1\ \Omega$. The real part must be produced by a 2.87- Ω resistor. The third element must be a capacitor because the imaginary part, the reactance, is negative. Of course, the capacitive reactance plus the inductive reactance equals the impedance reactance:

$$\frac{-1}{400C} + 400(16 \times 10^{-3}) = -4.1 \quad \text{from which} \quad C = 238\ \mu\text{F}$$

- 12.11** Find the input impedance at 5 krad/s of the circuit shown in Fig. 12-10a.

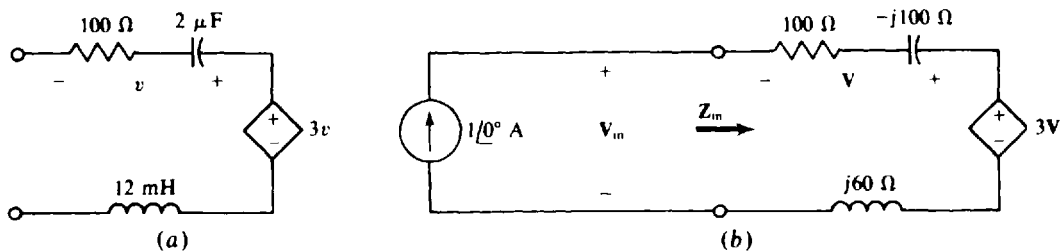

Fig. 12-10

The first step is to use $j\omega L$, $-j1/\omega C$, and phasors to construct the corresponding phasor-domain circuit that is shown in Fig. 12-10b along with a source of $1\angle 0^\circ\ \text{A}$. The presence of the dependent source makes it necessary to apply a source to find Z_{in} , and the best source is a current source of $1\angle 0^\circ\ \text{A}$ because with it, $Z_{in} = V_{in}/1\angle 0^\circ = V_{in}$. Note that the controlling voltage for the dependent source is the voltage drop across the resistor and capacitor:

$$V = -(1\angle 0^\circ)(100 - j100) = -100 + j100\ \text{V}$$

The initial negative sign is required because the voltage and current references are not associated. By KVL,

$$\begin{aligned} V_{in} &= (1\angle 0^\circ)(100) + (1\angle 0^\circ)(-j100) + 3(-100 + j100) + (1\angle 0^\circ)(j60) \\ &= 100 - j100 - 300 + j300 + j60 = -200 + j260 = 328\angle 128^\circ\ \text{V} \end{aligned}$$

Finally, $Z_{in} = V_{in} = 328\angle 128^\circ\ \Omega$.

- 12.12** A 240-V source is connected in series with two components, one of which has an impedance of $80\angle 60^\circ\ \Omega$. What is the impedance of the other component if the current that flows is 2 A and if it leads the source voltage by 40° ?

Since the total impedance is the sum of the known and unknown impedances, the unknown impedance is the total impedance minus the known impedance. The total impedance has a magnitude of

$$Z_T = \frac{V}{I} = \frac{240}{2} = 120 \Omega$$

and an angle of -40° , the angle by which the voltage leads the current. (This angle is negative because the voltage lags, instead of leads, the current.) Therefore, the total impedance is $Z_T = 120\angle-40^\circ \Omega$. Subtracting the known impedance of $80\angle60^\circ \Omega$ results in the desired impedance:

$$Z = 120\angle-40^\circ - 80\angle60^\circ = 91.9 - j77.1 - (40 + j69.3) = 51.9 - j146.3 = 155\angle-70.5^\circ \Omega$$

- 12.13** Find the total impedance of two parallel components that have impedances of $Z_1 = 300\angle30^\circ \Omega$ and $Z_2 = 400\angle-50^\circ \Omega$.

The total impedance is the product of the individual impedances divided by the sum:

$$Z_T = \frac{Z_1 Z_2}{Z_1 + Z_2} = \frac{(300\angle30^\circ)(400\angle-50^\circ)}{300\angle30^\circ + 400\angle-50^\circ} = \frac{120\,000\angle-20^\circ}{540\angle-16.8^\circ} = 222\angle-3.2^\circ \Omega$$

- 12.14** Find the total impedances at 1 krad/s of a 1-H inductor and a 1- μ F capacitor connected in series and also in parallel.

The inductor and capacitor impedances are

$$j\omega L = j1000(1) = j1000 \Omega \quad \text{and} \quad \frac{-j1}{\omega C} = \frac{-j1}{1000(10^{-6})} = -j1000 \Omega$$

The total impedance of the elements in series is the sum of the individual impedances: $Z = j1000 - j1000 = 0 \Omega$, which is a short circuit. For the two in parallel, the total impedance is

$$Z = \frac{j1000(-j1000)}{j1000 - j1000} = \frac{10^6}{0} \rightarrow \infty \Omega$$

which is an open circuit.

- 12.15** What capacitor and resistor connected in series have the same total impedance at 400 rad/s as a 10- μ F capacitor and a 500- Ω resistor connected in parallel?

At 400 rad/s, the impedance of the 10- μ F capacitor is

$$\frac{-j1}{\omega C} = \frac{-j1}{400(10 \times 10^{-6})} = -j250 \Omega$$

The total impedance of the parallel combination is, of course, the product of the individual impedances divided by the sum:

$$\frac{500(-j250)}{500 - j250} = \frac{125\,000\angle-90^\circ}{559\angle-26.6^\circ} = 224\angle-63.4^\circ = 100 - j200 \Omega$$

For the series resistor and capacitor to have this impedance, the resistor resistance must be 100 Ω , the real part, and the capacitor reactance must be -200Ω , the imaginary part. So, $R = 100 \Omega$, and by the capacitor reactance formula,

$$\frac{-1}{\omega C} = \frac{-1}{400C} = -200 \Omega \quad \text{from which} \quad C = \frac{1}{200(400)} \text{ F} = 12.5 \mu\text{F}$$

- 12.16** What two circuit elements connected in series have the same total impedance at 4 krad/s as the parallel combination of a 50- μ F capacitor and a 2-mH coil with a 10- Ω winding resistance?

The impedance of the coil is

$$10 + j4000(2 \times 10^{-3}) = 10 + j8 = 12.8/\underline{38.7} \Omega$$

and that of the capacitor is

$$\frac{-j1}{4000(50 \times 10^{-6})} = -j5 = 5/\underline{-90} \Omega$$

The impedance of the parallel combination is the product of these impedances divided by the sum:

$$\frac{(12.8/\underline{38.7}) \times (5/\underline{-90})}{10 + j8 - j5} = \frac{64/\underline{-51.3}}{10.44/\underline{16.7}} = 6.13/\underline{-68} = 2.29 - j5.69 \Omega$$

To produce an impedance of $2.29 - j5.69 \Omega$, the two series components must be a resistor that has a resistance of 2.29Ω and a capacitor that has a reactance of -5.69Ω . Since $X_C = -1/\omega C$,

$$C = \frac{-1}{\omega X_C} = \frac{-1}{4000(-5.69)} \text{ F} = 44 \mu\text{F}$$

- 12.17** For the circuit shown in Fig. 12-11, find the indicated unknown phasors and the corresponding sinusoids. The frequency is 60 Hz. Also, find the average power delivered by the source.

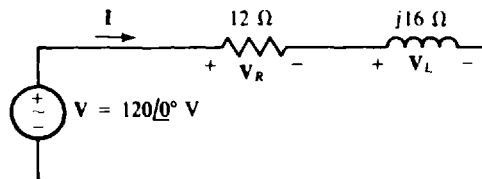

Fig. 12-11

Since this is a series circuit, the current can be found first and then used to find the voltages:

$$\mathbf{I} = \frac{\mathbf{V}}{\mathbf{Z}} = \frac{120/\underline{0}}{12 + j16} = \frac{120/\underline{0}}{20/\underline{53.1}} = 6/\underline{-53.1} \text{ A}$$

The resistor and inductor voltage drops are the products of this current and the individual impedances:

$$\mathbf{V}_R = (6/\underline{-53.1}) \times (12) = 72/\underline{-53.1} \text{ V}$$

$$\mathbf{V}_L = (6/\underline{-53.1}) \times (j16) = (6/\underline{-53.1}) \times (16/\underline{90}) = 96/\underline{36.9} \text{ V}$$

The radian frequency needed for the corresponding sinusoids is $\omega = 2\pi(60) = 377 \text{ rad/s}$. The peak values of the sinusoids are, of course, the magnitudes of the corresponding phasors times $\sqrt{2}$. Thus,

$$i = 6\sqrt{2} \sin(377t - 53.1^\circ) = 8.49 \sin(377t - 53.1^\circ) \text{ A}$$

$$v_R = 72\sqrt{2} \sin(377t - 53.1^\circ) = 102 \sin(377t - 53.1^\circ) \text{ V}$$

$$v_L = 96\sqrt{2} \sin(377t + 36.9^\circ) = 136 \sin(377t + 36.9^\circ) \text{ V}$$

Since the average power absorbed by the inductor is zero, the average power delivered by the source is the same as that absorbed by the resistor, which is $I^2 R = 6^2 \times 12 = 432 \text{ W}$.

- 12.18** Find the current and unknown voltages in the circuit shown in Fig. 12-12a.

The first step is to draw the corresponding phasor-domain circuit shown in Fig. 12-12b using the $\omega = 4000 \text{ rad/s}$ of the source. Since sinusoidal results are desired, it is best to use phasors based on

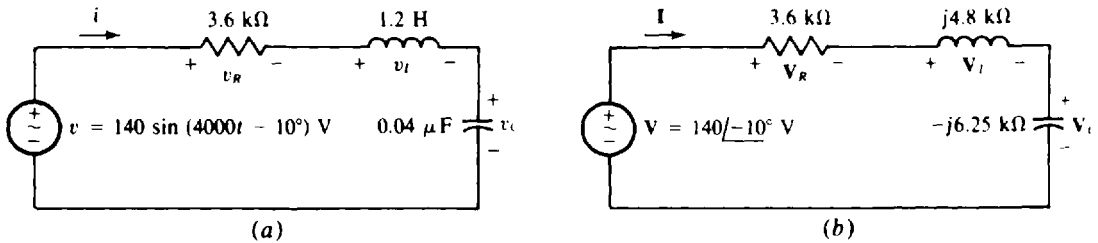

Fig. 12-12

peak rather than on rms values. That is why the source in Fig. 12-12b has a voltage of $140\angle-10^\circ$ V instead of $99\angle-10^\circ$ V ($99 = 140/\sqrt{2}$). The current is

$$\mathbf{I} = \frac{\mathbf{V}}{\mathbf{Z}} = \frac{140\angle-10^\circ}{3600 + j4800 - j6250} = \frac{140\angle-10^\circ}{3881\angle-21.9^\circ} \text{ A} = 36.1\angle11.9^\circ \text{ mA}$$

This current can be used to obtain the voltage phasors:

$$\begin{aligned} \mathbf{V}_R &= (0.0361\angle11.9^\circ)(3600) = 130\angle11.9^\circ \text{ V} \\ \mathbf{V}_L &= (0.0361\angle11.9^\circ)(4800\angle90^\circ) = 173\angle102^\circ \text{ V} \\ \mathbf{V}_C &= (0.0361\angle11.9^\circ)(6250\angle-90^\circ) = 225\angle-78.1^\circ \text{ V} \end{aligned}$$

The corresponding sinusoidal quantities are

$$\begin{aligned} i &= 36.1 \sin(4000t + 11.9^\circ) \text{ mA} \\ v_R &= 130 \sin(4000t + 11.9^\circ) \text{ V} \\ v_L &= 173 \sin(4000t + 102^\circ) = 173 \cos(4000t + 12^\circ) \text{ V} \\ v_C &= 225 \sin(4000t - 78.1^\circ) \text{ V} \end{aligned}$$

12.19 A voltage $100\angle30^\circ$ V is applied across a resistor and inductor that are in series. If the resistor rms voltage drop is 40 V, what is the inductor voltage phasor?

A funicular diagram is useful here. Since the resistor voltage is in phase with the current, and the inductor voltage leads the current by 90° , the phasor funicular diagram is a right triangle, as shown in Fig. 12-13. This particular diagram is useful only for finding the phasor magnitude and the *relative* phasor angular relations, the latter because the phasors are not at the correct angles. By Pythagoras' theorem, $V_L = \sqrt{100^2 - 40^2} = 91.7$ V. The shown angle θ is $\theta = \tan^{-1}(91.7/40) = 66.4^\circ$. The angle of the resistor voltage is less than the source voltage angle by this 66.4° : $\phi = 30^\circ - 66.4^\circ = -36.4^\circ$. The angle of the inductor voltage is, of course, 90° greater than the resistor voltage angle: $90^\circ + (-36.4^\circ) = 53.6^\circ$. So, the inductor voltage phasor is $\mathbf{V}_L = 91.7\angle53.6^\circ$ V.

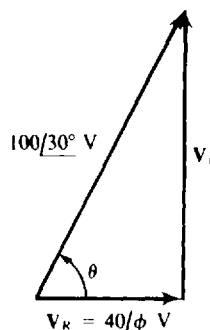

Fig. 12-13

- 12.20** In a phasor-domain circuit, $220\angle 30^\circ$ V is applied across two series components, one of which is a $20\text{-}\Omega$ resistor and the other of which is a coil with an impedance of $40\angle 20^\circ \Omega$. Use current to find the individual component voltage drops.

The current is

$$\mathbf{I} = \frac{\mathbf{V}}{\mathbf{Z}} = \frac{220\angle 30^\circ}{20 + 40\angle 20^\circ} = \frac{220\angle 30^\circ}{59.2\angle 13.4^\circ} = 3.72\angle 16.6^\circ \text{ A}$$

Each component voltage drop is the product of the current and the component impedance:

$$\mathbf{V}_R = (3.72\angle 16.6^\circ)(20) = 74\angle 16.6^\circ \text{ V}$$

$$\mathbf{V}_Z = (3.72\angle 16.6^\circ)(40\angle 20^\circ) = 149\angle 36.6^\circ \text{ V}$$

- 12.21** Repeat Prob. 12.20 using voltage division.

Voltage division eliminates the step of finding the current. Instead, the voltages are found directly from the applied voltage and the impedances:

$$\mathbf{V}_R = \frac{R}{\mathbf{Z}_T} \mathbf{V}_S = \frac{20}{59.2\angle 13.4^\circ} \times 220\angle 30^\circ = 74\angle 16.6^\circ \text{ V}$$

$$\mathbf{V}_Z = \frac{\mathbf{Z}_Z}{\mathbf{Z}_T} \mathbf{V}_S = \frac{40\angle 20^\circ}{59.2\angle 13.4^\circ} \times 220\angle 30^\circ = 149\angle 36.6^\circ \text{ V}$$

- 12.22** A phasor-domain circuit has $200\angle 15^\circ$ V applied across three series-connected components having impedances of $20\angle 15^\circ$, $30\angle -40^\circ$, and $40\angle 50^\circ \Omega$. Use voltage division to find the voltage drop \mathbf{V} across the component with the impedance of $40\angle 50^\circ \Omega$.

$$\mathbf{V} = \frac{40\angle 50^\circ}{20\angle 15^\circ + 30\angle -40^\circ + 40\angle 50^\circ} \times 200\angle 15^\circ = \frac{8000\angle 65^\circ}{70\angle 13.7^\circ} = 114\angle 51.3^\circ \text{ V}$$

- 12.23** Use voltage division to find \mathbf{V}_R , \mathbf{V}_L , and \mathbf{V}_C in the circuit shown in Fig. 12-14.

For voltage division, the total impedance \mathbf{Z} is needed: $\mathbf{Z} = 20 + j1000 - j1000 = 20 \Omega$. Incidentally, since this impedance is purely resistive, the circuit is in *resonance*. By the voltage division formula,

$$\mathbf{V}_R = \frac{20}{20} \times 100\angle 30^\circ = 100\angle 30^\circ \text{ V}$$

$$\mathbf{V}_L = \frac{j1000}{20} \times 100\angle 30^\circ = (50\angle 90^\circ)(100\angle 30^\circ) = 5000\angle 120^\circ \text{ V}$$

$$\mathbf{V}_C = \frac{-j1000}{20} \times 100\angle 30^\circ = (50\angle -90^\circ)(100\angle 30^\circ) = 5000\angle -60^\circ \text{ V}$$

Notice that the rms inductor and capacitor voltages are 50 times greater than the rms source voltage. This voltage rise, although impossible in a dc resistive circuit, is common in a series resonant ac circuit.

- 12.24** Use voltage division to find the voltage \mathbf{V} in the circuit shown in Fig. 12-15.

Because the two voltage sources are in series, they produce a net applied voltage that is the sum of the individual source voltages: $\mathbf{V}_S = 90\angle 60^\circ + 100\angle 30^\circ = 184\angle 44.2^\circ$ V, which is the voltage needed for the voltage division formula. The series components that \mathbf{V} is across have a combined impedance of $\mathbf{Z} = 50 - j60 + j70 = 50 + j10 = 51\angle 11.3^\circ \Omega$. The total circuit impedance is

$$\mathbf{Z}_T = 30 + j40 + 50 - j60 + j70 + 80 = 160 + j50 = 168\angle 17.4^\circ \Omega$$

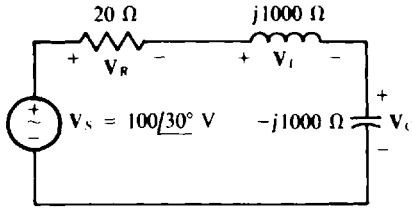

Fig. 12-14

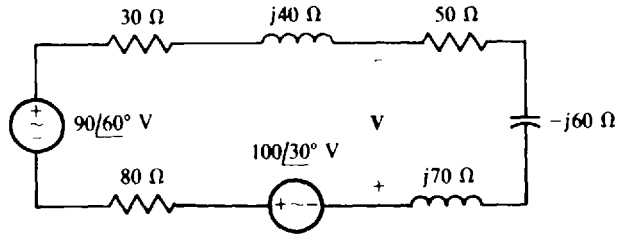

Fig. 12-15

Now, all the quantities have been calculated that are needed for the voltage division formula, which is

$$V = -\frac{Z}{Z_T} V_S = -\frac{51/11.3}{168/17.4} \times 184/44.2^\circ = -55.8/38.1^\circ \text{ V}$$

The negative sign is required in the formula because the reference polarity of V does not oppose the polarities of the sources.

12.25 Find the current I in the circuit shown in Fig. 12-16.

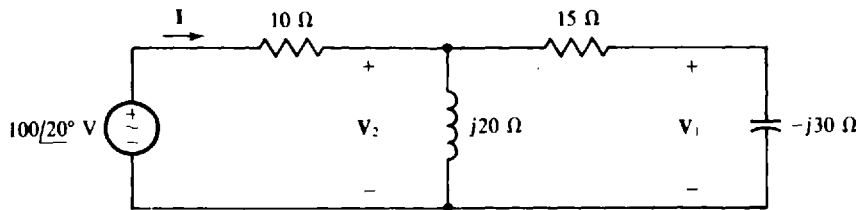

Fig. 12-16

The current can be found by dividing the voltage by the total impedance, and this impedance can be found by combining impedances starting at the end of the circuit opposite the source. There, the series resistor and capacitor have a combined impedance of $15 - j30 = 33.5/ -63.4^\circ \Omega$. This can be combined in parallel fashion with the $j20 \Omega$ of the parallel inductor:

$$\frac{j20(33.5/ -63.4^\circ)}{j20 + 15 - j30} = \frac{671/26.6^\circ}{18/ -33.7^\circ} = 37.2/60.3^\circ = 18.5 + j32.3 \Omega$$

This plus the 10Ω of the series resistor is the total impedance:

$$Z = 10 + 18.5 + j32.3 = 43.1/48.6^\circ \Omega$$

Finally, the current I is

$$I = \frac{V}{Z} = \frac{100/20^\circ}{43.1/48.6^\circ} = 2.32/ -28.6^\circ \text{ A}$$

12.26 Use voltage division twice to find V_1 in the circuit shown in Fig. 12-16.

Voltage division can be used to find V_2 from the source voltage, and used again to find V_1 from V_2 . For the calculation of V_2 , the equivalent impedance to the right of the $10\text{-}\Omega$ resistor is needed. It is $37.2/60.3^\circ = 18.5 + j32.3 \Omega$, as was found in the solution to Prob. 12-25. By voltage division,

$$V_2 = -\frac{37.2/60.3^\circ}{10 + 18.5 + j32.3} \times 100/20^\circ = -\frac{3720/80.3^\circ}{43.1/48.6^\circ} = 86.4/32^\circ \text{ V}$$

And, by voltage division again,

$$V_1 = \frac{-j30}{15 - j30} \times 86.4 \angle 32^\circ = \frac{2590 \angle -58^\circ}{33.5 \angle -63^\circ} = 77.3 \angle 5^\circ \text{ V}$$

12.27 Derive expressions for the conductance and the susceptance of an admittance in terms of the resistance and reactance of the corresponding impedance.

In general,

$$Y = \frac{1}{Z} = \frac{1}{R + jX}$$

Rationalizing,

$$Y \times \frac{1}{R + jX} \times \frac{R - jX}{R - jX} = \frac{R}{R^2 + X^2} + j \frac{-X}{R^2 + X^2}$$

Since $Y = G + jB$,

$$G = \frac{R}{R^2 + X^2} \quad \text{and} \quad B = \frac{-X}{R^2 + X^2}$$

Notice from $G = R/(R^2 + X^2)$ and $B = -X/(R^2 + X^2)$ that the conductance and the susceptance are both functions of the resistance and reactance. Also, $G \neq 1/R$ except if $X = 0$. And, $B \neq 1/X$. However, $B = -1/X$ if $R = 0$.

12.28 The impedance of a circuit has 2Ω of resistance and 4Ω of reactance. What are the conductance and susceptance of the admittance?

The expressions developed in the solution to Prob. 12.27 can be used:

$$G = \frac{2}{2^2 + 4^2} = \frac{2}{20} = 0.1 \text{ S} \quad \text{and} \quad B = \frac{-4}{2^2 + 4^2} = \frac{-4}{20} = -0.2 \text{ S}$$

But, in general, it is easier to use the inverse of impedance:

$$Y = \frac{1}{Z} = \frac{1}{2 + j4} = \frac{1}{4.47 \angle 63.4^\circ} = 0.224 \angle -63.4^\circ = 0.1 - j0.2 \text{ S}$$

The real part is the conductance: $G = 0.1 \text{ S}$; the imaginary part is the susceptance: $B = -0.2 \text{ S}$.

12.29 Find the total admittances in polar form of a $0.2\text{-}\mu\text{F}$ capacitor and a parallel $5.1\text{-}\Omega$ resistor at frequencies of (a) 0 Hz , (b) 100 kHz , and (c) 40 MHz .

The total admittance is $Y = G + j\omega C = 1/R + j2\pi fC$.

(a) For $f = 0 \text{ Hz}$,

$$Y = 1/5.1 + j2\pi(0)(0.2 \times 10^{-6}) = 0.196 = 0.196 \angle 0^\circ \text{ S}$$

(b) For $f = 100 \text{ kHz}$,

$$Y = 1/5.1 + j2\pi(100 \times 10^3)(0.2 \times 10^{-6}) = 0.196 + j0.126 = 0.233 \angle 32.7^\circ \text{ S}$$

(c) For $f = 40 \text{ MHz}$,

$$Y = 1/5.1 + j2\pi(40 \times 10^6)(0.2 \times 10^{-6}) = 0.196 + j50.3 = 50.3 \angle 89.8^\circ \text{ S}$$

At 40 MHz , the susceptance is so much larger than the conductance that the conductance is negligible for most purposes.

- 12.30** A 200- Ω resistor, a 1- μ F capacitor, and a 75-mH inductor are in parallel. Find the total admittance in polar form at 400 Hz. Also, draw the admittance diagram and the admittance triangle.

The total admittance is

$$\begin{aligned} Y &= \frac{1}{R} + j2\pi fC + \frac{-j1}{2\pi fL} = \frac{1}{200} + j2\pi(400)(1 \times 10^{-6}) + \frac{-j1}{2\pi(400)(75 \times 10^{-3})} \\ &= 5 \times 10^{-3} + j2.51 \times 10^{-3} - j5.31 \times 10^{-3} = (5 - j2.8) \times 10^{-3} \text{ S} = 5.73 \angle -29.2 \text{ mS} \end{aligned}$$

The admittance diagram is shown in Fig. 12-17a and the admittance triangle in Fig. 12-17b. In the admittance diagram, the end point for the Y arrow is found by starting at the origin and moving down the vertical axis to $-j5.31 \text{ mS}$ (jB_L), and then by moving horizontally to the right to over 5 mS (G) and vertically up by 2.51 mS (B_C).

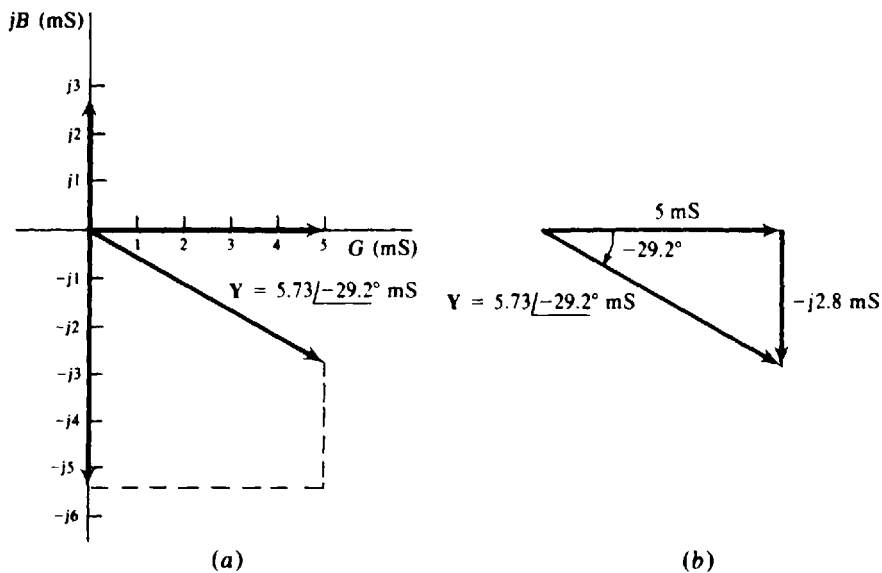

Fig. 12-17

- 12.31** A 100- Ω resistor, a 1-mH inductor, and a 0.1- μ F capacitor are in parallel. Find the total admittances in polar form at radian frequencies of (a) 50 krad/s, (b) 100 krad/s, and (c) 200 krad/s.

The expression for the total admittance is $Y = 1/R + j\omega C - j1/\omega L$.

$$\begin{aligned} (a) \quad Y &= \frac{1}{100} + j(50 \times 10^3)(0.1 \times 10^{-6}) - \frac{j1}{(50 \times 10^3)(10^{-3})} \\ &= 0.01 + j0.005 - j0.02 = 0.01 - j0.015 = 0.018 \angle -56.3^\circ \text{ S} \end{aligned}$$

$$(b) \quad Y = \frac{1}{100} + j(10^5)(0.1 \times 10^{-6}) - \frac{j1}{10^5(10^{-3})} = 0.01 + j0.01 - j0.01 = 0.01 \angle 0^\circ \text{ S}$$

$$\begin{aligned} (c) \quad Y &= \frac{1}{100} + j(2 \times 10^5)(0.1 \times 10^{-6}) - \frac{j1}{(2 \times 10^5)(10^{-3})} = 0.01 + j0.02 - j0.005 \\ &= 0.01 + j0.015 = 0.018 \angle 56.3^\circ \text{ S} \end{aligned}$$

Notice for $\omega = 100 \text{ krad/s}$ in part (b) that the admittance is real because the inductive and capacitive susceptance terms cancel. Consequently, this is the resonant radian frequency of the circuit. For lower frequencies, the circuit is inductive, as is verified in part (a). And for greater frequencies, the circuit is capacitive, as is verified in part (c). This response is opposite that for a series RLC circuit.

- 12.32** Three components in parallel have a total admittance of $Y_T = 6/\underline{30}^\circ$ S. If the admittances of two of the component are $Y_1 = 4/\underline{45}^\circ$ S and $Y_2 = 7/\underline{60}^\circ$ S, what is the admittance Y_3 of the third component?

Since $Y_T = Y_1 + Y_2 + Y_3$,

$$Y_3 = Y_T - Y_1 - Y_2 = 6/\underline{30}^\circ - 4/\underline{45}^\circ - 7/\underline{60}^\circ = 6/\underline{-101}^\circ \text{ S}$$

- 12.33** What is the total impedance of three parallel components that have impedances of $Z_1 = 2.5/\underline{75}^\circ \Omega$, $Z_2 = 4/\underline{-50}^\circ \Omega$, and $Z_3 = 5/\underline{45}^\circ \Omega$?

Perhaps the best approach is to invert each impedance to find the corresponding admittance, add the individual admittances to obtain the total admittance, and then invert the total admittance to find the total impedance.

Inverting,

$$Y_1 = \frac{1}{Z_1} = \frac{1}{2.5/\underline{75}^\circ} = 0.4/\underline{-75}^\circ \text{ S} \quad Y_2 = \frac{1}{Z_2} = \frac{1}{4/\underline{-50}^\circ} = 0.25/\underline{50}^\circ \text{ S} \quad Y_3 = \frac{1}{Z_3} = \frac{1}{5/\underline{45}^\circ} = 0.2/\underline{-45}^\circ \text{ S}$$

Adding, $Y_T = Y_1 + Y_2 + Y_3 = 0.4/\underline{-75}^\circ + 0.25/\underline{50}^\circ + 0.2/\underline{-45}^\circ = 0.527/\underline{-39.7}^\circ \text{ S}$

Inverting, $Z_T = \frac{1}{Y_T} = \frac{1}{0.527/\underline{-39.7}^\circ} = 1.9/\underline{39.7}^\circ \Omega$

- 12.34** Find the simplest parallel circuit that has the same impedance at 400 Hz as the series combination of a 300- Ω resistor, a 0.25-H inductor, and a 1- μ F capacitor.

The parallel circuit can be determined from the admittance, which can be found by inverting the impedance:

$$Y = \frac{1}{300 + j2\pi(400)(0.25) - j1/[2\pi(400)(10^{-6})]} = \frac{1}{300 + j230} = \frac{1}{378/\underline{37.5}^\circ} \\ = 2.64 \times 10^{-3} / \underline{-37.5}^\circ \text{ S} = 2.096 - j1.61 \text{ mS}$$

The simplest parallel circuit that has this admittance is a parallel resistor and inductor. From the real part of the admittance, this resistor must have a conductance of 2.096 mS and so a resistance of $1/(2.096 \times 10^{-3}) = 477 \Omega$. And from the imaginary part, the inductor must have a susceptance of -1.61 mS. The corresponding inductance is, from $B_L = -1/\omega L$,

$$L = \frac{-1}{\omega B_L} = \frac{-1}{2\pi(400)(-1.61 \times 10^{-3})} \text{ H} = 247 \text{ mH}$$

- 12.35** A load has a voltage of $V = 120/\underline{20}^\circ$ V and a current of $I = 48/\underline{60}^\circ$ A, both at 2 kHz. Find the two-element parallel circuit that the load can be. As always, assume associated references because there is no statement to the contrary.

Because the two elements are in parallel, the load admittance should be used to find them:

$$Y = \frac{I}{V} = \frac{48/\underline{60}^\circ}{120/\underline{20}^\circ} = 0.4/\underline{40}^\circ = 0.3064 + j0.2571 \text{ S}$$

The real part 0.3064 is, of course, the conductance of a resistor. The corresponding resistance is $R = 1/0.3064 = 3.26 \Omega$. The imaginary part 0.2571, being positive, is the susceptance of a capacitor. From $B_C = \omega C$,

$$C = \frac{B_C}{\omega} = \frac{0.2571}{2\pi(2000)} \text{ F} = 20.5 \mu\text{F}$$

- 12.36** A $0.5\text{-}\Omega$ resistor is in parallel with a 10-mH inductor. At what radian frequency do the circuit voltage and current have a phase angle difference of 40° ?

A good approach is to find the susceptance from the admittance angle and the conductance, and then find the radian frequency from the susceptance and the inductance. The admittance angle has a magnitude of 40° because this is the phase angle difference between the voltage and current, and it is negative because this is an inductive circuit. So, $\theta = -40^\circ$. Then from $\theta = \tan^{-1}(B_L/G)$,

$$B_L = G \tan \theta = (1/0.5) \tan(-40^\circ) = -1.678 \text{ S}$$

And, from the formula for inductive susceptance, $B_L = -1/\omega L$,

$$\omega = \frac{-1}{LB_L} = \frac{-1}{0.01(-1.678)} = 59.6 \text{ rad/s}$$

- 12.37** A resistor and a parallel $1\text{-}\mu\text{F}$ capacitor draw 0.48 A when 120 V at 400 Hz is applied. Find the admittance in polar form.

The magnitude of the admittance is $Y = I/V = 0.48/120 \text{ S} = 4 \text{ mS}$. From admittance triangle considerations, the angle of the admittance is $\theta = \sin^{-1}(B/Y)$. Since $B = \omega C$,

$$\frac{B}{Y} = \frac{\omega C}{Y} = \frac{2\pi(400)(10^{-6})}{0.004} = 0.2\pi$$

and $\theta = \sin^{-1} 0.2\pi = 38.9^\circ$. Therefore, the admittance is $Y = 4/38.9 \text{ mS}$.

- 12.38** Capacitors are sometimes connected in parallel with inductive industrial loads to decrease the current drawn from the source without affecting the load current. To verify this concept, consider connecting a capacitor across a coil that has 10 mH of inductance and $2 \text{ }\Omega$ of resistance and that is energized by a 60-Hz , 120-V source. What is the capacitance required to make the source current a minimum, and what is the decrease in this current?

Since $I = YV$, the current magnitude will be a minimum when the admittance magnitude Y is a minimum. The total admittance Y is the sum of the admittances of the coil and capacitor:

$$\begin{aligned} Y &= \frac{1}{R + j\omega L} + j\omega C = \frac{1}{2 + j2\pi(60)(10 \times 10^{-3})} + j2\pi(60)C = \frac{1}{2 + j3.77} + j377C \\ &= 0.110 - j0.207 + j377C \end{aligned}$$

Because the capacitance can affect only the susceptance, the admittance magnitude is a minimum for zero susceptance. For this,

$$377C = 0.207 \quad \text{from which} \quad C = \frac{0.207}{377} \text{ F} = 549 \text{ }\mu\text{F}$$

With zero susceptance, $Y = 0.110 \text{ S}$ and $|I| = |Y||V| = 0.110(120) = 13.2 \text{ A}$. In comparison, before the capacitor was added, the magnitude of the current was equal to the product of the magnitudes of the coil admittance and voltage: $|0.110 - j0.207|(120) = 0.234(120) = 28.1 \text{ A}$. So, the parallel capacitor causes a decrease in source current of $28.1 - 13.2 = 14.9 \text{ A}$ even though the coil current remains the same 28.1 A . What happens is that some of the coil current flows through the capacitor instead of through the source. Incidentally, since the susceptance is zero, the circuit is in resonance.

- 12.39** Find the total impedance Z_T of the circuit shown in Fig. 12-18.

This is, of course, a ladder circuit. Although for such a circuit it is possible to find Z_T by using only impedance (or admittance), it is usually best to alternate admittance and impedance, using admittance for parallel branches and impedance for series branches. This will be done starting at the end opposite the input.

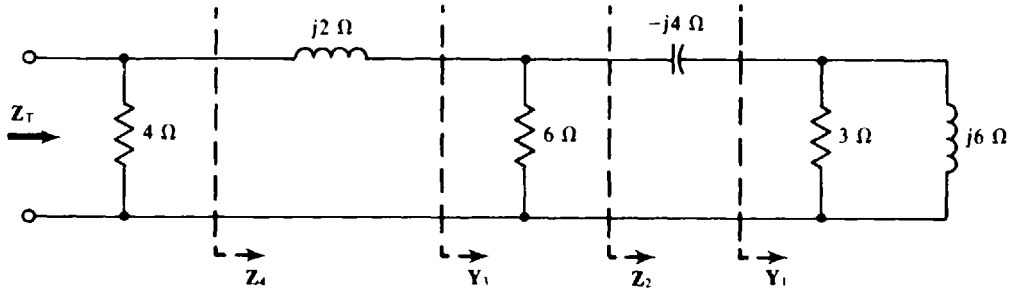

Fig. 12-18

There, the 3- and $j6\text{-}\Omega$ elements have a combined admittance of

$$Y_1 = \frac{1}{3} - j\frac{1}{6} = 0.373\angle -26.6^\circ \text{ S}$$

which corresponds to an impedance of

$$\frac{1}{0.373\angle -26.6^\circ} = 2.68\angle 26.6^\circ = 2.4 + j1.2 \Omega$$

This adds to the $-j4 \Omega$ of the series capacitor for an impedance of

$$Z_2 = 2.4 + j1.2 - j4 = 2.4 - j2.8 = 3.69\angle -49.4^\circ \Omega$$

The inverse of this added to the conductance of the parallel 6- Ω resistor is

$$Y_3 = \frac{1}{3.69\angle -49.4^\circ} + \frac{1}{6} = 0.176 + j0.206 + 0.167 = 0.4\angle 31^\circ \text{ S}$$

The corresponding impedance adds to the $j2 \Omega$ of the series inductor:

$$Z_4 = \frac{1}{0.4\angle 31^\circ} + j2 = 2.14 - j1.29 + j2 = 2.26\angle 18.4^\circ \Omega$$

The corresponding admittance plus the conductance of the 4- Ω resistor is Y_T :

$$Y_T = \frac{1}{2.26\angle 18.4^\circ} + \frac{1}{4} = 0.42 - j0.14 + 0.25 = 0.684\angle -11.8^\circ \text{ S}$$

Finally,

$$Z_T = \frac{1}{Y_T} = \frac{1}{0.684\angle -11.8^\circ} = 1.46\angle 11.8^\circ \Omega$$

12.40 Find the input admittance at 50 krad/s of the circuit shown in Fig. 12-19a.

The first step is to use $-j1/\omega L$, G , $j\omega C$, and phasors to construct the corresponding phasor-domain circuit shown in Fig. 12-19b along with a source of $1\angle 0^\circ \text{ V}$. With this source, the circuit has an input

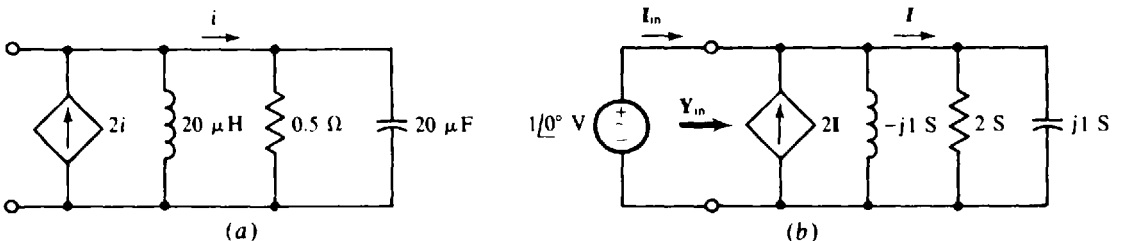

Fig. 12-19

admittance of $Y_{in} = I_{in}/1\angle 0^\circ = I_{in}$. Note that the controlling current I is the sum of the currents in the two right-hand branches:

$$I = (1\angle 0^\circ)(2) + (1\angle 0^\circ)(j1) = 2 + j1 \text{ A}$$

And so the dependent-source current flowing down is $-2I = -2(2 + j1)$. This can be used in a KCL equation at the top node to obtain I_{in} :

$$I_{in} = -2(2 + j1) + (1\angle 0^\circ)(-j1) + 2 + j1 = -2 - j2 = 2.83\angle -135^\circ \text{ A}$$

Finally, $Y_{in} = I_{in} = 2.83\angle -135^\circ \text{ S}$

12.41 Find I_{in} and I_L for the circuit shown in Fig. 12-20.

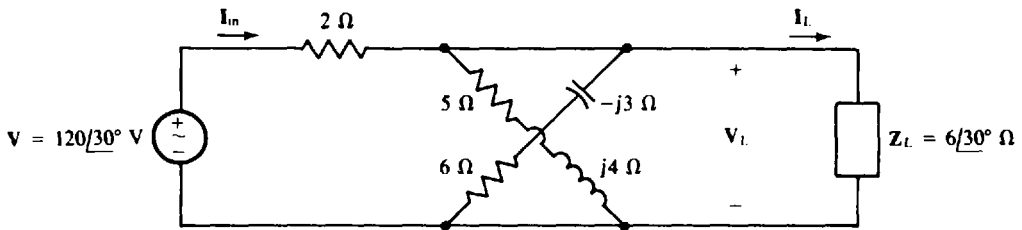

Fig. 12-20

The current I_{in} can be found from the source voltage divided by the input impedance Z_{in} , which equals the 2Ω of the series resistor plus the total impedance of the three branches to the right of this resistor. Since these branches extend between the same two nodes, they are in parallel and have a total admittance Y that is the sum of the individual admittances:

$$Y = \frac{1}{5 + j4} + \frac{1}{6 - j3} + \frac{1}{6\angle 30^\circ} = 0.156\angle -38.7^\circ + 0.149\angle 26.6^\circ + 0.167\angle -30^\circ = 0.416\angle -16^\circ \text{ S}$$

Adding the 2Ω to the inverse of this admittance results in

$$Z_{in} = 2 + \frac{1}{Y} = 2 + \frac{1}{0.416\angle -16^\circ} = 2 + 2.41\angle 16^\circ = 4.36\angle 8.72^\circ \Omega$$

from which

$$I_{in} = \frac{V}{Z_{in}} = \frac{120\angle 30^\circ}{4.36\angle 8.72^\circ} = 27.5\angle 21.3^\circ \text{ A}$$

The current I_L can be found from the load voltage and impedance. The load voltage V_L is equal to the current I_{in} divided by the total admittance of the three parallel branches:

$$V_L = \frac{I_{in}}{Y} = \frac{27.5\angle 21.3^\circ}{0.416\angle -16^\circ} = 66.2\angle 37^\circ \text{ V}$$

and

$$I_L = \frac{V_L}{Z_L} = \frac{66.2\angle 37^\circ}{6\angle 30^\circ} = 11\angle 7^\circ \text{ A}$$

Alternatively, I_L can be found directly from I_{in} by current division. I_L is equal to the product of I_{in} and the admittance of the load divided by the total admittance of the three parallel branches:

$$I_L = 27.5\angle 21.3^\circ \times \frac{0.167\angle -30^\circ}{0.416\angle -16^\circ} = 11\angle 7^\circ \text{ A}$$

12.42 A current of $4\angle 30^\circ \text{ A}$ flows into four parallel branches that have admittances of $6\angle -70^\circ$, $5\angle 30^\circ$, $7\angle 60^\circ$, and $9\angle 45^\circ \text{ S}$. Use current division to find the current I in the $5\angle 30^\circ \text{ S}$ branch. Of course, since

there is no statement to the contrary, assume that the current references are such that the current division formula does not have a negative sign.

The current I in the branch with the admittance of $5/30$ S is equal to this admittance divided by the sum of the admittances, all times the input current:

$$I = \frac{5/30}{6/(-70^\circ) + 5/30^\circ + 7/60 + 9/45} \times 4/30 = \frac{20/60}{18.7/29.8} = 1.07/30.2 \text{ A}$$

12.43 Use current division to find I_L for the circuit shown in Fig. 12-21.

Since there are just two branches and the branch impedances are specified, the impedance form of the current division formula is preferable: The current in one branch is equal to the impedance of the other branch divided by the sum of the impedances, all times the input current. For this circuit, though, a negative sign is required because the input current and I_L have reference directions into the same node—the bottom node:

$$I_L = -\frac{6}{6 + j9} \times 4/20 = \frac{-24/20}{10.8/56.3} = -2.22/-36.3 \text{ A}$$

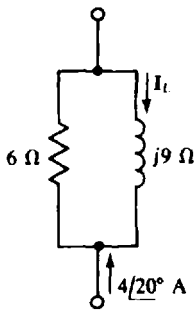

Fig. 12-21

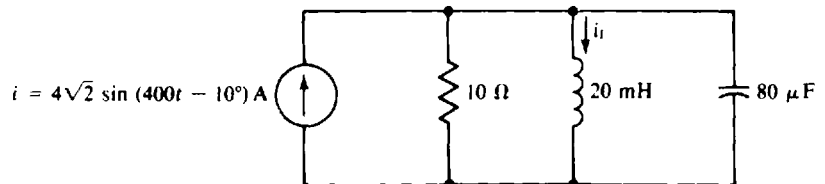

Fig. 12-22

12.44 Use current division to find i_L for the circuit shown in Fig. 12-22.

The individual admittances are

$$G = \frac{1}{10} = 0.1 \text{ S} \quad jB_L = -\frac{j1}{\omega L} = \frac{-j1}{400(20 \times 10^{-3})} = -j0.125 \text{ S} \quad jB_C = j\omega C = j400(80 \times 10^{-6}) = j0.032 \text{ S}$$

These substituted into the current division formula give

$$I_L = \frac{jB_L}{G + jB_L + jB_C} \times I = \frac{-j0.125}{0.1 - j0.125 + j0.032} \times 4/-10 = \frac{(0.125/-90) \times (4/-10)}{0.1366/-42.9} = 3.66/-57.1 \text{ A}$$

from which $i_L = 3.66\sqrt{2} \sin(400t - 57.1^\circ) = 5.18 \sin(400t - 57.1^\circ) \text{ A}$

12.45 Use current division twice to find the current I_L for the circuit shown in Fig. 12-23.

The approach is to find I from the source current by current division, and then find I_L from I by current division. For the I current division formula, the impedance to the right of the $2\text{-}\Omega$ resistor is needed. It is

$$j3 + \frac{4(-j5)}{4 - j5} = j3 + 3.12/-38.7 = 2.65/23.3 \text{ }\Omega$$

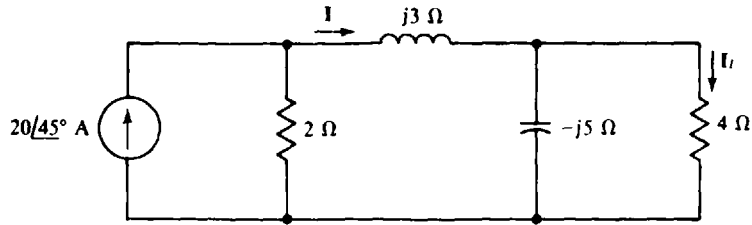

Fig. 12-23

By current division,

$$I = \frac{2}{2 + 2.65\angle 23.3^\circ} \times 20\angle 45^\circ = \frac{40\angle 45^\circ}{4.56\angle 13.3^\circ} = 8.77\angle 31.7^\circ \text{ A}$$

By current division again,

$$I_L = \frac{-j5}{4 - j5} \times 8.77\angle 31.7^\circ = \frac{43.8\angle -58.3^\circ}{6.4\angle -51.3^\circ} = 6.85\angle -7^\circ \text{ A}$$

12.46 Determine V_o and I_o in the circuit of Fig. 12-24.

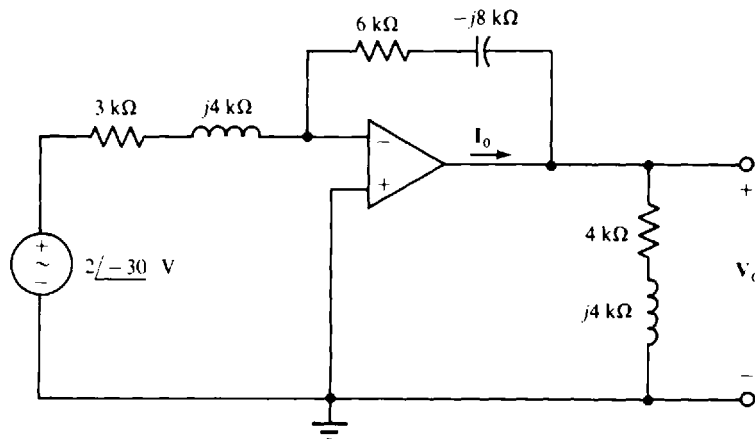

Fig. 12-24

Because this circuit has the same configuration as the inverter op-amp circuit of Fig. 6-4, the same formula applies, with the R 's replaced by Z 's. The feedback impedance is $Z_f = 6 - j8 \text{ k}\Omega$ and the input impedance is $Z_i = 3 + j4 \text{ k}\Omega$. Therefore, with the impedances expressed in kilohms,

$$V_o = -\frac{Z_f}{Z_i} V_i = -\frac{6 - j8}{3 + j4} \times 2\angle -30^\circ = 4\angle 43.7^\circ \text{ V} \quad \text{and} \quad I_o = \frac{4\angle 43.7^\circ}{4 + j4} + \frac{4\angle 43.7^\circ}{6 - j8} = 0.762\angle 30.1^\circ \text{ mA}$$

12.47 Find v_o and i_o in the circuit of Fig. 12-25a.

The first step is to draw the corresponding phasor-domain circuit of Fig. 12-25b using the $\omega = 10\,000 \text{ rad/s}$ of the source. The shown peak value of 4 V for the source voltage phasor magnitude is preferable to the rms value because sinusoidal answers are desired.

Because the circuit of Fig. 12-25b has the same configuration as the noninverting amplifier of Fig. 6-6, the same voltage gain formula is valid, with the R 's replaced by Z 's. Here, $Z_f = 3 - j2 \text{ k}\Omega$ and

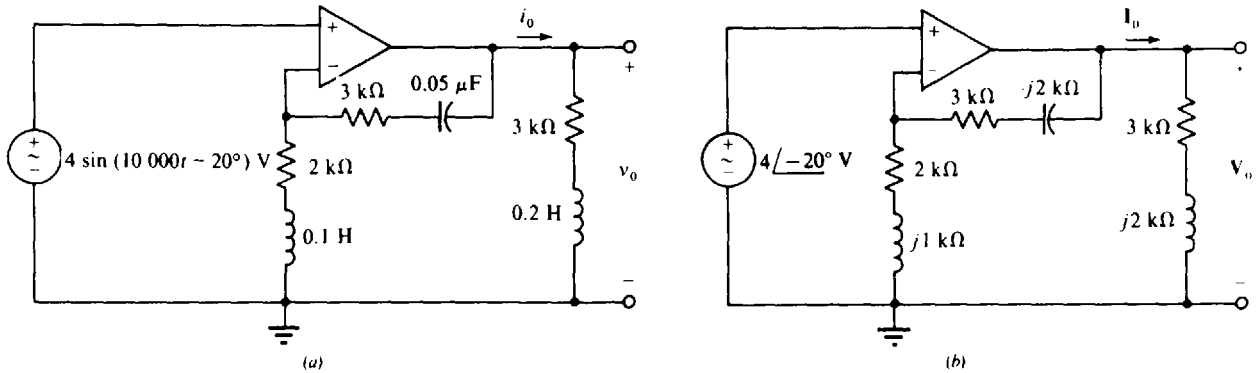

Fig. 12-25

$Z_a = 2 + j1 \text{ k}\Omega$. With the impedances expressed in kilohms,

$$V_o = \left(1 + \frac{Z_f}{Z_a}\right) V_i = \left(1 + \frac{3 - j2}{2 + j1}\right) \times 4\angle -20^\circ = 9.12\angle -57.9^\circ \text{ V}$$

and

$$I_o = \frac{9.12\angle -57.9^\circ}{3 + j2} = 2.53\angle -91.6^\circ \text{ mA}$$

The corresponding sinusoids are

$$v_o = 9.12 \sin(10\,000t - 57.9^\circ) \text{ V} \quad \text{and} \quad i_o = 2.53 \sin(10\,000t - 91.6^\circ) \text{ mA}$$

12.48 Calculate V_o in the circuit of Fig. 12-26.

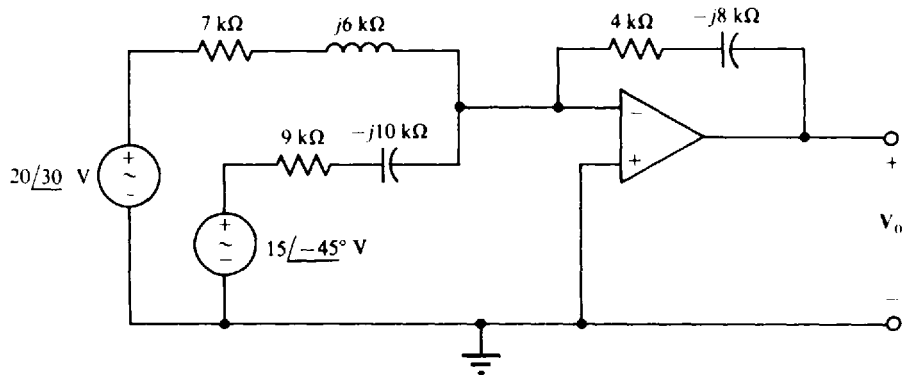

Fig. 12-26

Since the op-amp circuit of Fig. 12-26 has the same configuration as the summer of Fig. 6-5, the same formula applies, with the R 's replaced by Z 's. So, with the impedances expressed in kilohms,

$$V_o = -\left(\frac{4 - j8}{7 + j6} \times 20\angle 30^\circ + \frac{4 - j8}{9 - j10} \times 15\angle -45^\circ\right) = -29.2\angle -69.4^\circ \text{ V}$$

12.49 Find I_o in the circuit of Fig. 12-27.

The circuit of Fig. 12-27 consists of two cascaded op-amp circuits that have configurations of, respectively, a noninverting voltage amplifier and an inverting voltage amplifier. Consequently, the noninvert-

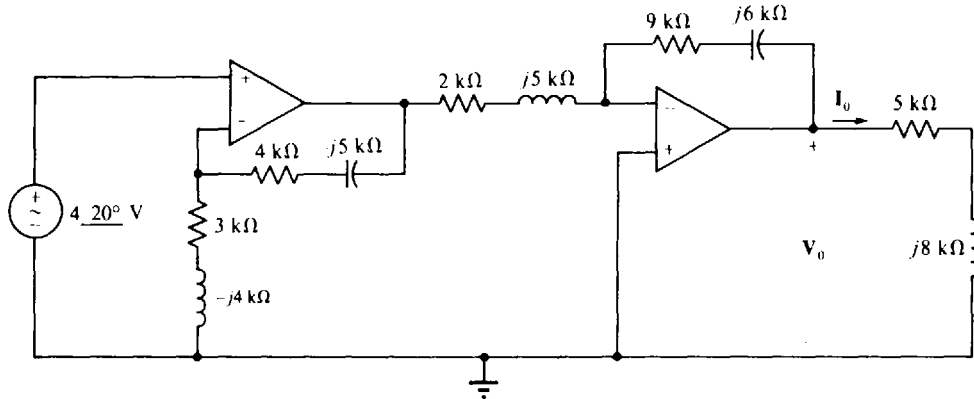

Fig. 12-27

ing and inverting formulas apply, with the R 's replaced by Z 's. Therefore,

$$V_o = \left(1 + \frac{4 - j5}{3 - j4}\right) \times 4\angle 20^\circ \times \left(-\frac{9 - j6}{2 + j5}\right) = 18.3/99.1 \text{ V}$$

$$\text{and } I_o = \frac{V_o}{5 + j8} = \frac{18.3/99.1}{5 + j8} = 1.94/41.1 \text{ mA}$$

12.50 Determine V_o in the circuit of Fig. 12-28.

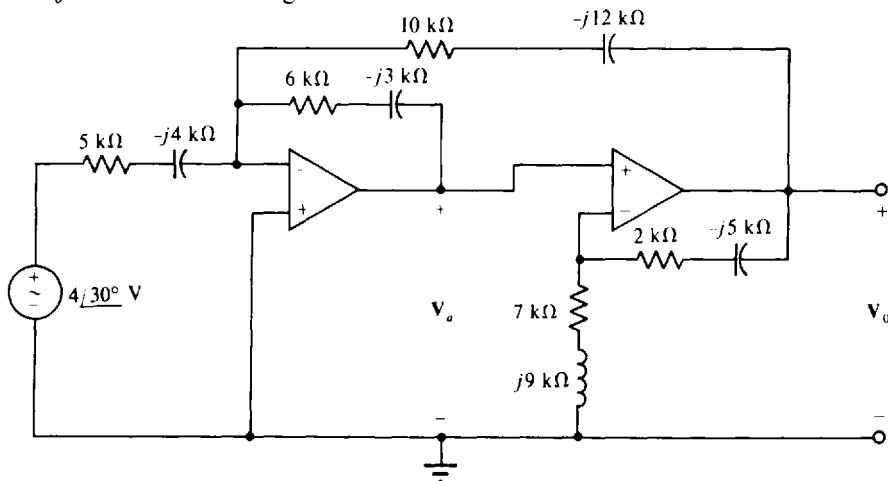

Fig. 12-28

The first op-amp circuit can be considered to be similar to a summer with one input of $4\angle 30^\circ$ V and the other of V_o . Then the output V_a is

$$V_a = -\left(\frac{6 - j3}{5 - j4} \times 4\angle 30^\circ + \frac{6 - j3}{10 - j12} V_o\right) = 4.19\angle -138^\circ + (0.429\angle -156^\circ) V_o$$

V_a is the input to the second op-amp circuit, which has a configuration similar to that of a noninverting amplifier. Consequently,

$$V_o = \left(1 + \frac{2 - j5}{7 + j9}\right) V_a = \frac{9 + j4}{7 + j9} [4.19\angle -138^\circ + (0.429\angle -156^\circ) V_o] = 3.62\angle -166^\circ + (0.371\angle 175^\circ) V_o$$

$$\text{Finally, } V_o = \frac{3.62\angle -166^\circ}{1 - 0.371\angle 175^\circ} = 2.64\angle -165^\circ \text{ V}$$

Supplementary Problems

- 12.51** A $0.5\text{-}\mu\text{F}$ capacitor and a $2\text{-k}\Omega$ resistor are in series. Find the total impedance in polar form at (a) 0 Hz, (b) 60 Hz, and (c) 10 kHz.
Ans. (a) $\infty \angle -90^\circ \Omega$, (b) $5.67 \angle -69.3^\circ \text{ k}\Omega$, (c) $2 \angle -0.912^\circ \text{ k}\Omega$
- 12.52** A $300\text{-}\Omega$ resistor, a 1-H inductor, and a $1\text{-}\mu\text{F}$ capacitor are in series. Find the total impedance in polar form and whether the circuit is inductive or capacitive at (a) 833 rad/s , (b) 1000 rad/s , and (c) 1200 rad/s .
Ans. (a) $474 \angle -50.8^\circ \Omega$, capacitive; (b) $300 \angle 0^\circ \Omega$, neither capacitive nor inductive; (c) $474 \angle 50.7^\circ \Omega$, inductive
- 12.53** A capacitor and resistor in series have an impedance of $1.34 \angle -45^\circ \text{ k}\Omega$ at 400 Hz. Find the capacitance and resistance.
Ans. $0.42 \mu\text{F}$, 948Ω
- 12.54** A load has a voltage of $240 \angle 75^\circ \text{ V}$ and a current of $20 \angle 60^\circ \text{ A}$ at a frequency of 60 Hz. Find the two-element series circuit that the load can be.
Ans. An $11.6\text{-}\Omega$ resistor and an 8.24-mH inductor
- 12.55** Two circuit elements in series draw a current of $16 \sin(200t + 35^\circ) \text{ A}$ in response to an applied voltage of $80 \cos 200t \text{ V}$. Find the two elements.
Ans. A $2.87\text{-}\Omega$ resistor and a 20.5-mH inductor
- 12.56** A $100\text{-}\Omega$ resistor is in series with a 120-mH inductor. At what frequency do the circuit voltage and current have a phase angle difference at 35° ?
Ans. 92.9 Hz
- 12.57** A $750\text{-}\Omega$ resistor is in series with a $0.1\text{-}\mu\text{F}$ capacitor. At what frequency does the total impedance have a magnitude of 1000Ω ?
Ans. 2.41 kHz
- 12.58** Find the total impedance in polar form of three series-connected components that have impedances of $10 \angle -40^\circ$, $12 \angle 65^\circ$, and $15 \angle -30^\circ \Omega$.
Ans. $25.9 \angle -6.77^\circ \Omega$
- 12.59** What resistor in series with a 2-H inductor limits the current to 120 mA when 120 V at 60 Hz is applied?
Ans. 657Ω
- 12.60** Two circuit elements in series draw a current of $24 \sin(5000t - 10^\circ) \text{ mA}$ in response to an applied voltage of $120\sqrt{2} \sin(5000t + 30^\circ) \text{ V}$. Find the two elements.
Ans. A $5.42\text{-k}\Omega$ resistor and a 0.909-H inductor
- 12.61** Find the input impedance at 20 krad/s for the circuit shown in Fig. 12-29.
Ans. $228 \angle 28.8^\circ \Omega$

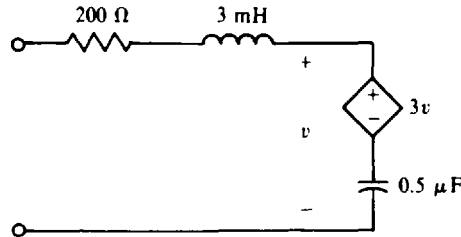

Fig. 12-29

12.62 A 300-V source is connected in series with three components, two of which have impedances of $40/\underline{30^\circ}\ \Omega$ and $30/\underline{-60^\circ}\ \Omega$. Find the impedance of the third component if the current that flows is 5 A and if it lags the source voltage by 20° .

Ans. $27.3/\underline{75.7^\circ}\ \Omega$

12.63 Find the total impedance of two parallel components that have identical impedances of $100/\underline{60^\circ}\ \Omega$.

Ans. $50/\underline{60^\circ}\ \Omega$

12.64 What is the total impedance of two parallel components that have impedances of $80/\underline{-30^\circ}$ and $60/\underline{40^\circ}\ \Omega$?

Ans. $41.6/\underline{10.7^\circ}\ \Omega$

12.65 A 120-mH coil with a 30- Ω winding resistance is in parallel with a 20- Ω resistor. What series resistor and inductor produce the same impedance at 60 Hz as this parallel combination?

Ans. 15.6 Ω , 10.6 mH

12.66 A 2-mH coil with a 10- Ω winding resistance is in parallel with a 10- μF capacitor. What two series circuit elements have the same impedance at 8 krad/s?

Ans. A 13.9- Ω resistor and a 7.2- μF capacitor

12.67 For the circuit shown in Fig. 12-30, find I , V_R , and V_C , and the corresponding sinusoidal quantities if the frequency is 50 Hz. Also, find the average power delivered by the source.

$$\begin{aligned} \text{Ans. } I &= 7.5/\underline{81.3^\circ}\ \text{A} & V_R &= 150/\underline{81.3^\circ}\ \text{V} \\ V_C &= 187/\underline{-8.66^\circ}\ \text{V} & i &= 10.6 \sin(314t + 81.3^\circ)\ \text{A} \\ v_R &= 212 \sin(314t + 81.3^\circ)\ \text{V} & v_C &= 265 \sin(314t - 8.66^\circ)\ \text{V} \end{aligned}$$

Average power delivered = 1.12 kW

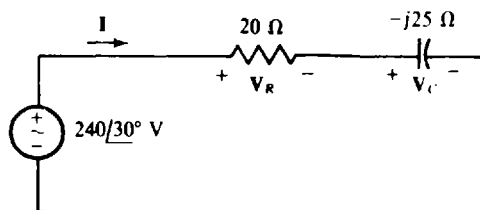

Fig. 12-30

12.68 A voltage source of $340 \sin(1000t + 25^\circ)\ \text{V}$, a 2- Ω resistor, a 1-H inductor, and a 1- μF capacitor are in series. Find the current out of the positive terminal of the source. Also, find the resistor, inductor, and capacitor voltage drops.

$$\begin{aligned} \text{Ans. } i &= 170 \sin(1000t + 25^\circ)\ \text{A} & v_R &= 340 \sin(1000t + 25^\circ)\ \text{V} \\ v_L &= 170 \cos(1000t + 25^\circ)\ \text{kV} & v_C &= 170 \sin(1000t - 65^\circ)\ \text{kV} \end{aligned}$$

- 12.69 A voltage that has a phasor of $200/\underline{-40^\circ}$ V is applied across a resistor and capacitor that are in series. If the capacitor rms voltage is 120 V, what is the resistor voltage phasor?

Ans. $160/\underline{-3.13^\circ}$ V

- 12.70 A phasor-domain circuit has $220/\underline{30^\circ}$ V applied across two components, a $30\text{-}\Omega$ resistor and a coil that has an impedance of $30/\underline{40^\circ}$ Ω . Find the voltage drops across the resistor and the coil.

Ans. Resistor voltage = $117/\underline{10^\circ}$ V, coil voltage = $117/\underline{50^\circ}$ V

- 12.71 A voltage source of $170 \sin(377t - 30^\circ)$ V, a $200\text{-}\Omega$ resistor, and a $10\text{-}\mu\text{F}$ capacitor are in series. Find the resistor and capacitor voltage drops.

Ans. $v_R = 102 \sin(377t + 23^\circ)$ V, $v_C = 136 \sin(377t - 67^\circ)$ V

- 12.72 Repeat Prob. 12.71 with an added series 1-H inductor. Also, find the inductor voltage.

Ans. $v_R = 148 \sin(377t - 59^\circ)$ V, $v_C = 197 \sin(377t - 149^\circ)$ V, $v_L = 280 \sin(377t + 31^\circ)$ V

- 12.73 A phasor-domain circuit has $500/\underline{40^\circ}$ V applied across three series-connected components that have impedances of $20/\underline{40^\circ}$, $30/\underline{-60^\circ}$, and $40/\underline{70^\circ}$ Ω . Find the component voltage drops.

Ans. $V_{20} = 199/\underline{50.9^\circ}$ V, $V_{30} = 298/\underline{-49.1^\circ}$ V, $V_{40} = 397/\underline{80.9^\circ}$ V

- 12.74 What is the current I for the circuit shown in Fig. 12-31?

Ans. $7.93/\underline{45.8^\circ}$ A

- 12.75 Use voltage division twice to find V in the circuit shown in Fig. 12-31.

Ans. $81.2/\underline{6.04^\circ}$ V

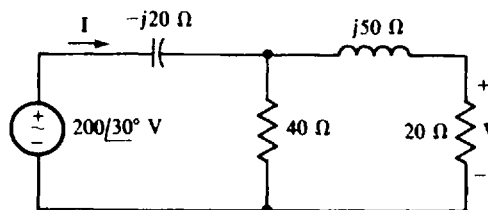

Fig. 12-31

- 12.76 Derive expressions for the resistance and reactance of an impedance in terms of the conductance and susceptance of the corresponding admittance.

Ans. $R = G/(G^2 + B^2)$, $X = -B/(G^2 + B^2)$

- 12.77 Find the total admittance in polar form of a $1\text{-}\mu\text{F}$ capacitor and a parallel $3.6\text{-k}\Omega$ resistor at (a) 5 Hz, (b) 44.2 Hz, and (c) 450 Hz.

Ans. (a) $0.28/\underline{6.45^\circ}$ mS, (b) $0.393/\underline{45^\circ}$ mS, (c) $2.84/\underline{84.4^\circ}$ mS

- 12.78 A $1\text{-k}\Omega$ resistor, a 1-H inductor, and a $1\text{-}\mu\text{F}$ capacitor are in parallel. Find the total admittance in polar form at (a) 500 rad/s, (b) 1000 rad/s, and (c) 5000 rad/s.

Ans. (a) $1.8/\underline{-56.3^\circ}$ mS, (b) $1/\underline{0^\circ}$ mS, (c) $4.9/\underline{78.2^\circ}$ mS

- 12.79 An inductor and a parallel resistor have an admittance of $100/\underline{-30^\circ}$ mS at 400 Hz. What are the inductance and resistance?

Ans. 7.96 mH, 11.5 Ω

12.80 Find the simplest series circuit that has the same total impedance at 400 Hz as the parallel arrangement of a 620-Ω resistor, a 0.5-H inductor, and a 0.5-μF capacitor.

Ans. A 573-Ω resistor and a 2.43-μF capacitor

12.81 A load has a voltage of $240/\underline{60}$ V and a current of $120/\underline{20}$ mA. What two-element parallel circuit can this load be at 400 Hz?

Ans. A 2.61-kΩ resistor and a 1.24-H inductor

12.82 A resistor and a parallel 0.5-μF capacitor draw 50 mA when 120 V at 60 Hz is applied. What is the total admittance in polar form and what is the resistance of the resistor?

Ans. $0.417/\underline{26.9}$ mS, 2.69 kΩ

12.83 What two circuit elements in parallel have an admittance of $0.4/\underline{-50}$ S at 60 Hz?

Ans. A 3.89-Ω resistor and an 8.66-mH inductor

12.84 What two circuit elements in parallel have an admittance of $2.5/\underline{30}$ mS at 400 Hz?

Ans. A 462-Ω resistor and a 0.497-μF capacitor

12.85 Three circuit elements in parallel have an admittance of $6.3/\underline{-40}$ mS at a frequency of 2 kHz. If one is a 60-mH inductor, what are the two other elements?

Ans. A 207-Ω resistor and a 29.2-mH inductor

12.86 A 2-kΩ resistor is in parallel with a 0.1-μF capacitor. At what frequency does the total admittance have an angle of 40°?

Ans. 668 Hz

12.87 A resistor and a parallel 120-mH inductor draw 3 A when 100 V at 60 Hz is applied. What is the total admittance?

Ans. $30/\underline{-47.5}$ mS

12.88 A certain industrial load has an impedance of $0.6/\underline{30}$ Ω at a frequency of 60 Hz. What capacitor connected in parallel with this load causes the angle of the total impedance to decrease to 15°? Also, if the load voltage is 120 V, what is the decrease in line current produced by adding the capacitor?

Ans. 1.18 mF, 20.7 A

12.89 Find the admittance *Y* of the circuit shown in Fig. 12-32.

Ans. $2.29/\underline{-42.2}$ S

12.90 Find the input admittance at 1 krad/s of the circuit shown in Fig. 12-33.

Ans. 4 S

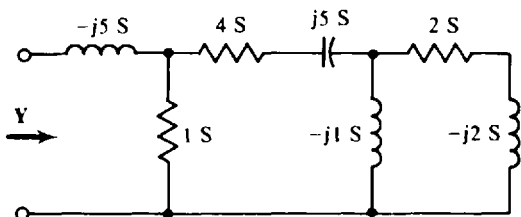

Fig. 12-32

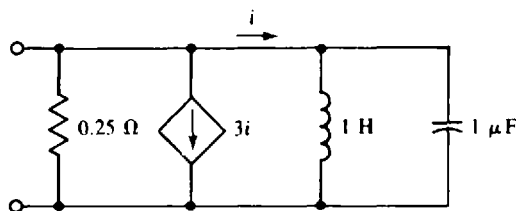

Fig. 12-33

12.91 Repeat Prob. 12.90 for a radian frequency of 1 Mrad/s.

Ans. $5.66/45$ S

12.92 A current of $20/30^\circ$ A flows into three parallel branches that have impedances of 200 , $j10$, and $-j10$ Ω . Find the current in the $j10$ - Ω branch.

Ans. $400/-60$ A

12.93 A current of $20 \sin(200t - 30^\circ)$ A flows into the parallel combination of a 100 - Ω resistor and a 25 - μ F capacitor. Find the capacitor current.

Ans. $8.94 \sin(200t + 33.4^\circ)$ A

12.94 A current of $20/-45^\circ$ A flows into three parallel branches that have impedances of $16/30^\circ$, $20/-45^\circ$, and $25/-60^\circ$ Ω . What is the current in the $25/-60^\circ$ Ω branch?

Ans. $6.89/-4.49$ A

12.95 Use current division twice to find I for the circuit shown in Fig. 12-34.

Ans. $1.41/-19.5$ A

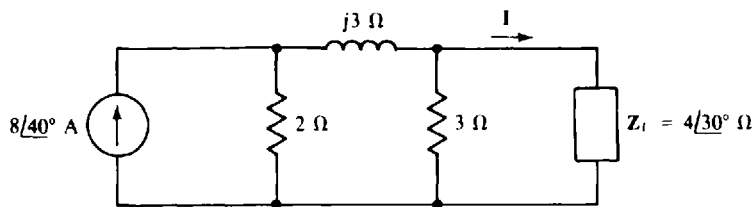

Fig. 12-34

12.96 Calculate I_o in the circuit of Fig. 12-35.

Ans. $0.419/-38.4$ mA

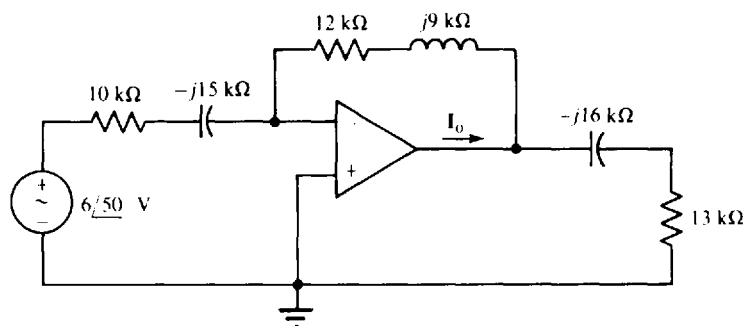

Fig. 12-35

12.97 Find i_o in the circuit of Fig. 12-36.

Ans. $0.441 \cos(10^4 t - 69.9^\circ)$ mA

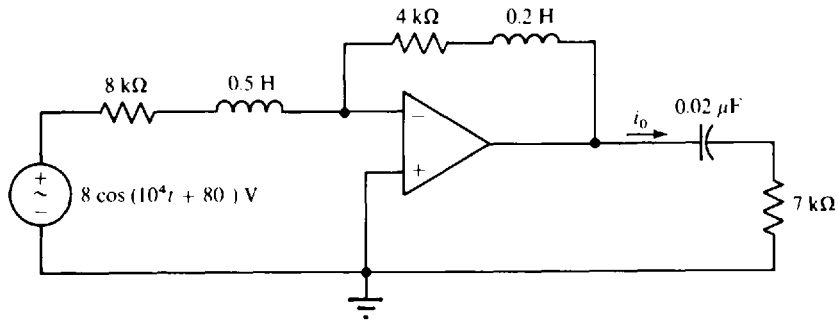

Fig. 12-36

12.98 Obtain V_o and I_o in the circuit of Fig. 12-37.

Ans. $7.49/-45.0$ V, $2.04/-20.1$ mA

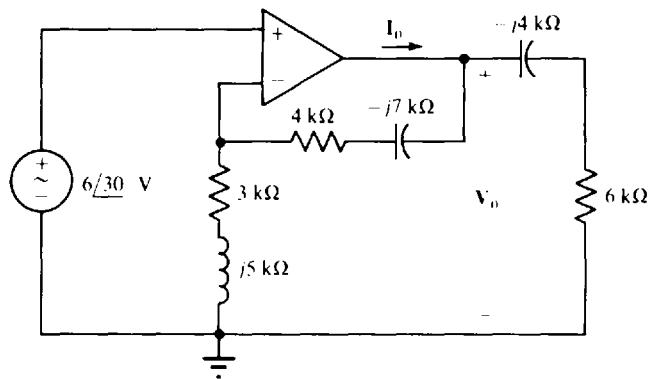

Fig. 12-37

12.99 Calculate V_o in the circuit of Fig. 12-38.

Ans. $-5.45/-13.0$ V

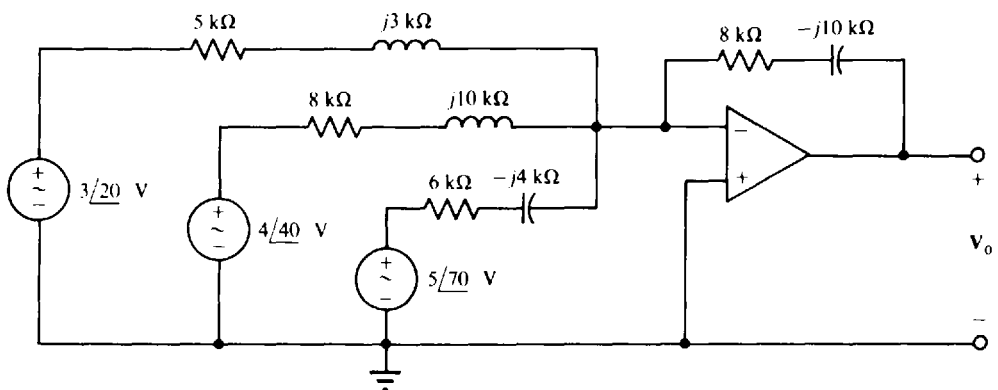

Fig. 12-38

12.100 Determine V_o and I_o in the circuit of Fig. 12-39.

Ans. $10.8 \angle -22.8^\circ$ V, $1.15 \angle 1.98^\circ$ mA

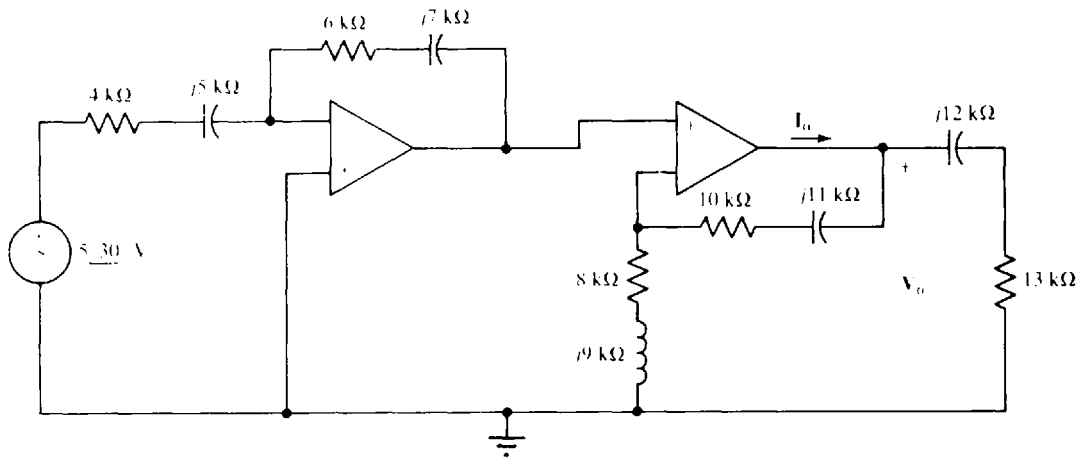

Fig. 12-39

12.101 Obtain v_o in the circuit of Fig. 12-40.

Ans. $7.40 \sin(8000t + 86.5^\circ)$ V

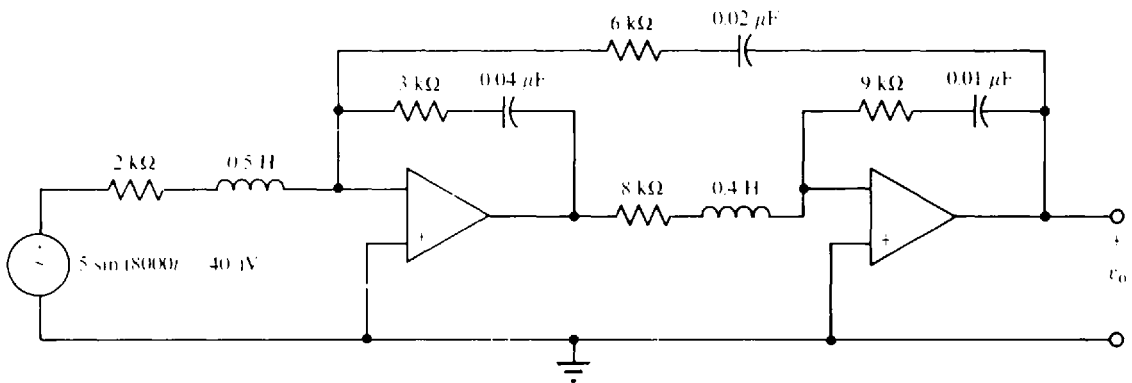

Fig. 12-40

Mesh, Loop, Nodal, and PSpice Analyses of AC Circuits

INTRODUCTION

The material in this chapter is similar to that in Chap. 4. Here, however, the analysis techniques apply to ac phasor-domain circuits instead of to dc resistive circuits and so to voltage and current phasors instead of to voltages and currents and to impedances and admittances instead of just to resistances and conductances. Also, an analysis is often considered completed after the unknown voltage or current phasors are determined. The final step of finding the actual time-function voltages and currents is often not done because they are not usually important. Besides, it is a simple matter to obtain them from the phasors.

One other introductory note: From this point on, the term “impedance” and “admittances” will often be used to mean *components with impedances* and *components with admittances*, as is common practice.

SOURCE TRANSFORMATIONS

As has been explained, mesh and loop analyses are usually easier to do with all current sources transformed to voltage sources and nodal analysis is usually easier to do with all voltage sources transformed to current sources. Figure 13-1a shows the rather obvious transformation from a voltage source to a current source, and Fig. 13-1b shows the transformation from a current source to a voltage source. In each circuit the rectangle next to Z indicates components that have a total impedance of Z . These components can be in any configuration and can, of course, include dependent sources—but not independent sources.

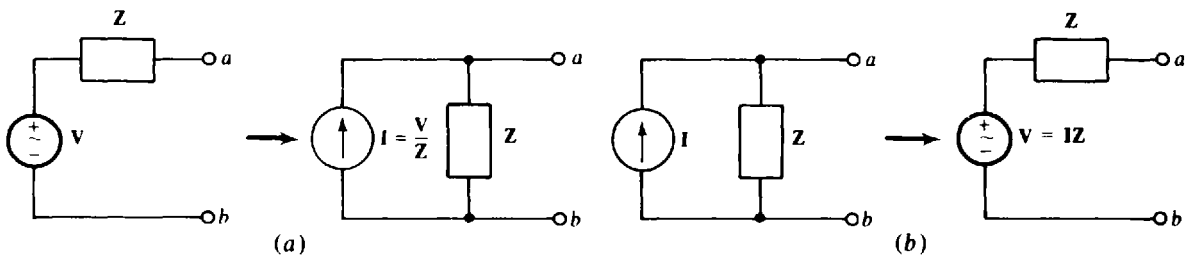

Fig. 13-1

MESH AND LOOP ANALYSES

Mesh analysis for phasor-domain circuits should be apparent from the presentation of mesh analysis for dc circuits in Chap. 4. Preferably all current sources are transformed to voltage sources, then clockwise-referenced mesh currents are assigned, and finally KVL is applied to each mesh.

As an illustration, consider the phasor-domain circuit shown in Fig. 13-2. The KVL equation for mesh 1 is

$$I_1 Z_1 + (I_1 - I_3) Z_2 + (I_1 - I_2) Z_3 = V_1 + V_2 - V_3$$

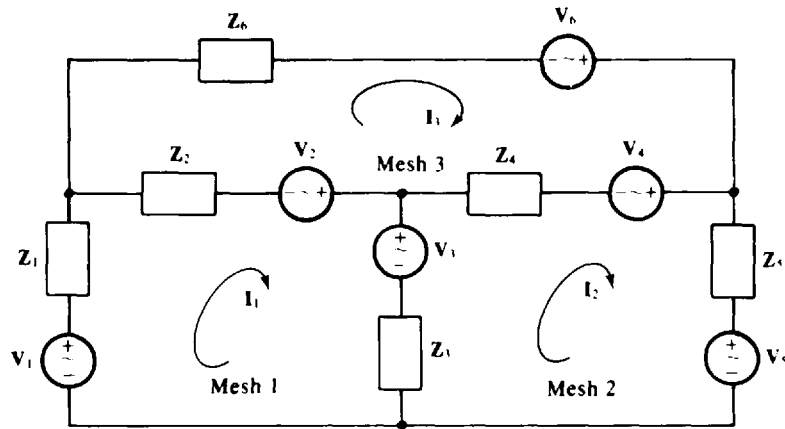

Fig. 13-2

where $I_1 Z_1$, $(I_1 - I_3)Z_2$, and $(I_1 - I_2)Z_3$ are the voltage drops across the impedances Z_1 , Z_2 , and Z_3 . Of course, $V_1 + V_2 - V_3$ is the sum of the voltage rises from voltage sources in mesh 1. As a memory aid, a source voltage is added if it "aids" current flow—that is, if the principal current has a direction out of the positive terminal of the source. Otherwise, the source voltage is subtracted.

This equation simplifies to

$$(Z_1 + Z_2 + Z_3)I_1 - Z_3 I_2 - Z_2 I_3 = V_1 + V_2 - V_3$$

The $Z_1 + Z_2 + Z_3$ coefficient of I_1 is the *self-impedance* of mesh 1, which is the sum of the impedances of mesh 1. The $-Z_3$ coefficient of I_2 is the negative of the impedance in the branch common to meshes 1 and 2. This impedance Z_3 is a *mutual impedance*—it is mutual to meshes 1 and 2. Likewise, the $-Z_2$ coefficient of I_3 is the negative of the impedance in the branch mutual to meshes 1 and 3, and so Z_2 is also a mutual impedance. It is important to remember in mesh analysis that the mutual terms have initial negative signs.

It is, of course, easier to write mesh equations using self-impedances and mutual impedances than it is to directly apply KVL. Doing this for meshes 2 and 3 results in

$$-Z_3 I_1 + (Z_3 + Z_4 + Z_5)I_2 - Z_4 I_3 = V_3 + V_4 - V_5$$

and

$$-Z_2 I_1 - Z_4 I_2 + (Z_2 + Z_4 + Z_6)I_3 = -V_2 - V_4 + V_6$$

Placing the equations together shows the symmetry of the I coefficients about the principal diagonal:

$$\begin{array}{rcl} (Z_1 + Z_2 + Z_3)I_1 - & Z_3 I_2 - & Z_2 I_3 = V_1 + V_2 - V_3 \\ -Z_3 I_1 + (Z_3 + Z_4 + Z_5)I_2 - & & Z_4 I_3 = V_3 + V_4 - V_5 \\ -Z_2 I_1 - & Z_4 I_2 + (Z_2 + Z_4 + Z_6)I_3 = & -V_2 - V_4 + V_6 \end{array}$$

Usually, there is no such symmetry if the corresponding circuit has dependent sources. Also, some of the off-diagonal coefficients may not have initial negative signs.

This symmetry of the coefficients is even better seen with the equations written in matrix form:

$$\begin{bmatrix} Z_1 + Z_2 + Z_3 & -Z_3 & -Z_2 \\ -Z_3 & Z_3 + Z_4 + Z_5 & -Z_4 \\ -Z_2 & -Z_4 & Z_2 + Z_4 + Z_6 \end{bmatrix} \begin{bmatrix} I_1 \\ I_2 \\ I_3 \end{bmatrix} = \begin{bmatrix} V_1 + V_2 - V_3 \\ V_3 + V_4 - V_5 \\ -V_2 - V_4 + V_6 \end{bmatrix}$$

For some scientific calculators, it is best to put the equations in this form and then key in the coefficients and constants so that the calculator can be used to solve the equations. The calculator-matrix method is generally superior to any other procedure such as Cramer's rule.

Loop analysis is similar except that the paths around which KVL is applied are not necessarily meshes, and the loop currents may not all be referenced clockwise. So, even if a circuit has no dependent

sources, some of the mutual impedance coefficients may not have initial negative signs. Preferably, the loop current paths are selected such that each current source has just one loop current through it. Then, these loop currents become known quantities with the result that it is unnecessary to write KVL equations for the loops or to transform any current sources to voltage sources. Finally, the required number of loop currents is $B - N + 1$ where B is the number of branches and N is the number of nodes. For a planar circuit, which is a circuit that can be drawn on a flat surface with no wires crossing, this number of loop currents is the same as the number of meshes.

NODAL ANALYSIS

Nodal analysis for phasor-domain circuits is similar to nodal analysis for dc circuits. Preferably, all voltage sources are transformed to current sources. Then, a reference node is selected and all other nodes are referenced positive in potential with respect to this reference node. Finally, KCL is applied to each nonreference node. Often the polarity signs for the node voltages are not shown because of the convention to reference these voltages positive with respect to the reference node.

For an illustration of nodal analysis applied to a phasor-domain circuit, consider the circuit shown in Fig. 13-3. The KCL equation for node 1 is

$$V_1 Y_1 + (V_1 - V_2) Y_2 + (V_1 - V_3) Y_6 = I_1 + I_2 - I_6$$

where $V_1 Y_1$, $(V_1 - V_2) Y_2$, and $(V_1 - V_3) Y_6$ are the currents flowing away from node 1 through the admittances Y_1 , Y_2 , and Y_6 . Of course, $I_1 + I_2 - I_6$ is the sum of the currents flowing into node 1 from current sources,

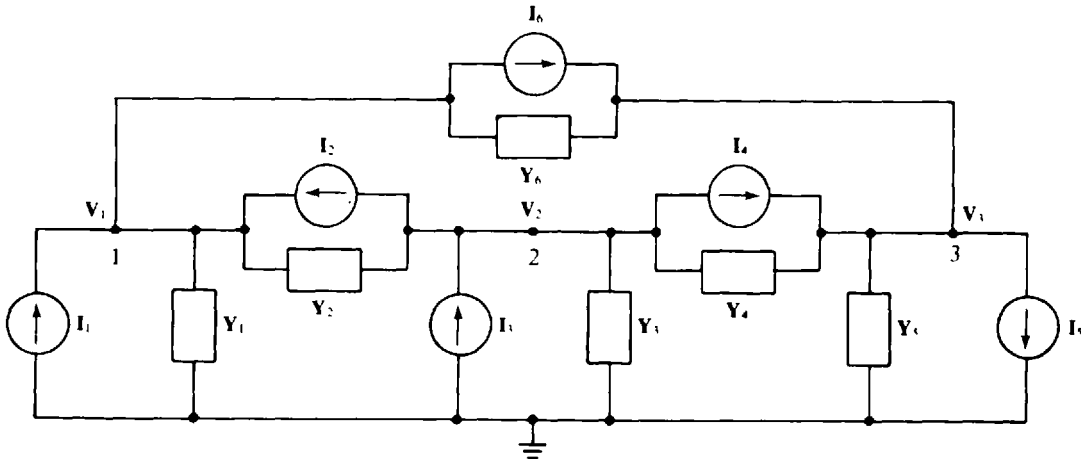

Fig. 13-3

This equation simplifies to

$$(Y_1 + Y_2 + Y_6)V_1 - Y_2 V_2 - Y_6 V_3 = I_1 + I_2 - I_6$$

The coefficient $Y_1 + Y_2 + Y_6$ of V_1 is the *self-admittance* of node 1, which is the sum of the admittances connected to node 1. The coefficient $-Y_2$ of V_2 is the negative of the admittance connected between nodes 1 and 2. So, Y_2 is a *mutual admittance*. Similarly, the coefficient $-Y_6$ of V_3 is the negative of the admittance connected between nodes 1 and 3, and so Y_6 is also a mutual admittance.

It is, of course, easier to write nodal equations using self-admittances and mutual admittances than it is to directly apply KCL. Doing this for nodes 2 and 3 produces

$$-Y_2 V_1 + (Y_2 + Y_3 + Y_4)V_2 - Y_4 V_3 = -I_2 + I_3 - I_4$$

and

$$-Y_6 V_1 - Y_4 V_2 + (Y_4 + Y_5 + Y_6)V_3 = I_4 - I_5 + I_6$$

Placing the equations together shows the symmetry of the Y coefficients about the principal diagonal:

$$\begin{aligned} (Y_1 + Y_2 + Y_6)V_1 - Y_2V_2 - Y_6V_3 &= I_1 + I_2 - I_6 \\ -Y_2V_1 + (Y_2 + Y_3 + Y_4)V_2 - Y_4V_3 &= -I_2 + I_3 - I_4 \\ -Y_6V_1 - Y_4V_2 + (Y_4 + Y_5 + Y_6)V_3 &= I_4 - I_5 + I_6 \end{aligned}$$

Usually, there is no such symmetry if the corresponding circuit has dependent sources. Also, some of the off-diagonal coefficients may not have initial negative signs. In matrix form these equations are

$$\begin{bmatrix} Y_1 + Y_2 + Y_6 & -Y_2 & -Y_6 \\ -Y_2 & Y_2 + Y_3 + Y_4 & -Y_4 \\ -Y_6 & -Y_4 & Y_4 + Y_5 + Y_6 \end{bmatrix} \begin{bmatrix} V_1 \\ V_2 \\ V_3 \end{bmatrix} = \begin{bmatrix} I_1 + I_2 - I_6 \\ -I_2 + I_3 - I_4 \\ I_4 - I_5 + I_6 \end{bmatrix}$$

PSPICE AC ANALYSIS

The use of PSpice to analyze an ac circuit is perhaps best introduced by way of an illustration. Consider the time-domain circuit of Fig. 13-4. A suitable PSpice circuit file for obtaining V_o and I_o is

```
CIRCUIT FILE FOR THE CIRCUIT OF FIG. 13-4
V1 1 0 AC 10 -20
R1 1 2 2K
C1 2 3 1U
R2 3 0 3K
I1 3 0 AC 3M 42
R3 3 4 4K
L1 4 0 5M
.AC LIN 1 159.155 159.155
.PRINT AC VM(C1) VP(C1) IM(L1) IP(L1)
.END
```

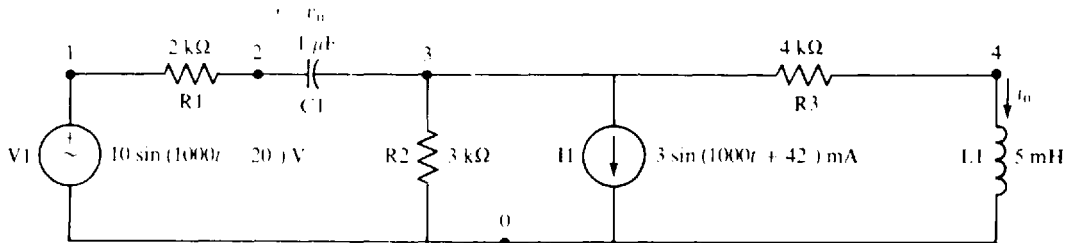

Fig. 13-4

Observe that the resistor, inductor, and capacitor statements are essentially the same as for the other types of analyses, except that no initial conditions are specified in the inductor and capacitor statements. If the circuit had contained a dependent source, the corresponding statement would have been the same also.

In the independent source statement, the term AC, which must be included after the node specification, is followed by the peak value of the sinusoidal source and then the phase angle. If rms magnitudes are desired in the printed outputs, then rms values instead of peak values, should be specified in the independent source statement.

The frequency of the sources (and all sources must have the same frequency), in hertz, is specified in an .AC control statement, after .AC LIN 1. Here the frequency is $1000/2\pi = 159.155$ Hz. (The source frequency of 1000 is, of course, in radians per second.) Note that this frequency must be specified twice. The format of the .AC control statement allows for the variation in frequency, a feature that is not used in this example.

The .PRINT statement requires the insertion of AC after .PRINT. After AC are specified the magnitudes (M) and phases (P) of the desired voltages and currents: VM(C1) specifies the magnitude of the voltage across capacitor C1, and VP(C1) specifies its phase; IM(L1) specifies the magnitude of the current flowing through inductor L1, and IP(L1) specifies its phase. If the results are desired in rectangular form, then the letters R for *real part* and I for *imaginary part* are used instead of M and P.

If this circuit file is run with PSpice, the output file will include the following:

```
*****
****      AC ANALYSIS
*****

      FREQ          VM(C1)      VP(C1)      IM(L1)      IP(L1)
1.592E+02      3.436E+00      -7.484E+01      6.656E-04      -4.561E+01
```

Consequently, $V_o = 3.436/\underline{-74.84}^\circ$ V and $I_o = 0.6656/\underline{-45.61}^\circ$ mA, where the magnitudes are expressed in peak values. As stated, if rms magnitudes are desired, then rms magnitudes should be specified in the independent source statements.

Solved Problems

13.1 Perform a source transformation on the circuit shown in Fig. 13-5.

The series impedance is $3 + j4 + 6(-j5) = 5.56/\underline{10.9}^\circ \Omega$, which when divided into the voltage of the original source gives the source current of the equivalent circuit:

$$\frac{20/\underline{30}^\circ}{5.56/\underline{10.9}^\circ} = 3.6/\underline{19.1}^\circ \text{ A}$$

As shown in Fig. 13-6, the current direction is toward node *a*, as it must be because the positive terminal of the voltage source is toward that node also. The parallel impedance is, of course, the series impedance of the original circuit.

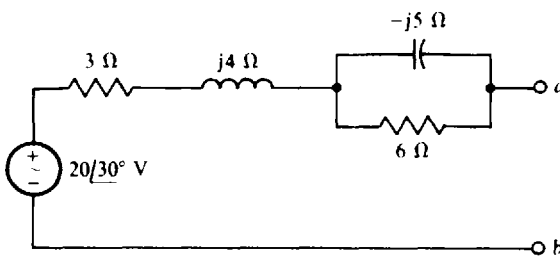

Fig. 13-5

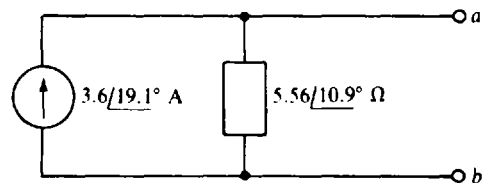

Fig. 13-6

13.2 Perform a source transformation on the circuit shown in Fig. 13-7.

This circuit has a dependent voltage source that provides a voltage in volts that is three times the current *I* flowing *elsewhere* (not shown) in the complete circuit. When, as here, the controlling quantity is not in the circuit being transformed, the transformation is the same as for a circuit with an independent

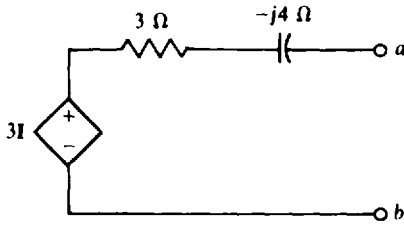

Fig. 13-7

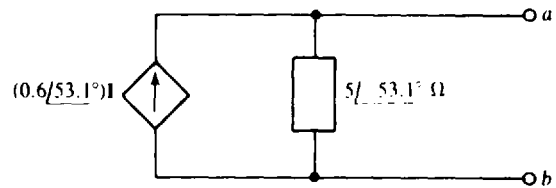

Fig. 13-8

source. Therefore, the parallel impedance is $3 - j4 = 5/\underline{-53.1} \Omega$, and the source current directed toward node a is

$$\frac{3I}{5/\underline{-53.1}} = (0.6/\underline{53.1})I$$

as shown in Fig. 13-8.

When the controlling quantity is in the portion of the circuit being transformed, a different method must be used, as is explained in Chap. 14 in the section on Thévenin's and Norton's theorems.

13.3 Perform a source transformation on the circuit shown in Fig. 13-9.

The parallel impedance is $6/(5 + j3) = 3.07/\underline{15.7} \Omega$. The product of the parallel impedance and the current is the voltage of the equivalent voltage source:

$$(4/\underline{-35}) \parallel (3.07/\underline{15.7}) = 12.3/\underline{-19.3} \text{ V}$$

As shown in Fig. 13-10, the positive terminal of the voltage source is toward node a , as it must be since the current of the original circuit is toward that node also. The source impedance is, of course, the same $3.07/\underline{15.7} \Omega$, but is in series with the source instead of in parallel with it.

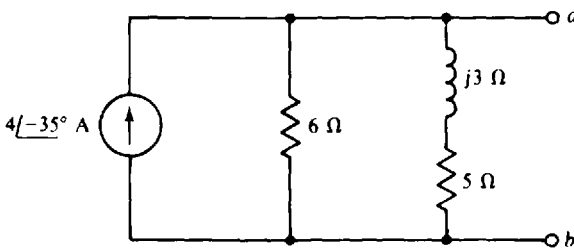

Fig. 13-9

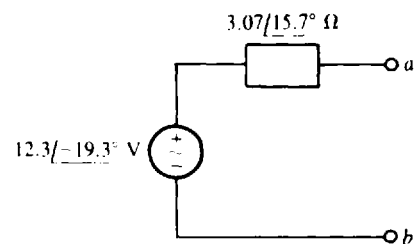

Fig. 13-10

13.4 Perform a source transformation on the circuit shown in Fig. 13-11.

This circuit has a dependent current source that provides a current flow in amperes that is six times the voltage V across a component *elsewhere* (not shown) in the complete circuit. Since the controlling quantity is not in the circuit being transformed, the transformation is the same as for a circuit with an independent source. Consequently, the series impedance is $5(4 - j6) = 3.33/\underline{-22.6} \Omega$, and the source voltage is

$$6V \times 3.33/\underline{-22.6} = (20/\underline{-22.6})V$$

with, as shown in Fig. 13-12, the positive polarity toward node a because the current of the current source is also toward that node. The same source impedance is, of course, in the circuit, but is in series with the source instead of in parallel with it.

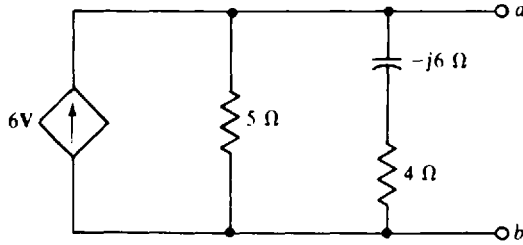

Fig. 13-11

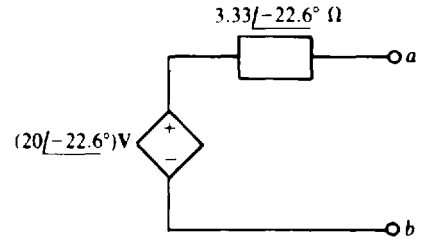

Fig. 13-12

13.5 Assume that the following equations are mesh equations for a circuit that does not have any current sources or dependent sources. Find the quantities that go in the blanks.

$$\begin{aligned} (16 - j5)I_1 & \quad \text{_____} I_2 - (3 + j2)I_3 = 4 - j2 \\ -(4 + j3)I_1 + (18 + j9)I_2 & - (6 - j8)I_3 = 10/20^\circ \\ \text{_____} I_1 & \quad \text{_____} I_2 + (20 + j10)I_3 = 14 + j11 \end{aligned}$$

The key is the required symmetry of the I coefficients about the principal diagonal. Because of this symmetry, the coefficient of I_2 in the first equation must be $-(4 + j3)$, the same as the coefficient of I_1 in the second equation. Also, the coefficient of I_1 in the third equation must be $-(3 + j2)$, the same as the coefficient of I_3 in the first equation. And the coefficient of I_2 in the third equation must be $-(6 - j8)$, the same as the coefficient of I_3 in the second equation.

13.6 Find the voltages across the impedances in the circuit shown in Fig. 13-13a. Then transform the voltage source and $10/30^\circ\text{-}\Omega$ component to an equivalent current source and again find the voltages. Compare results.

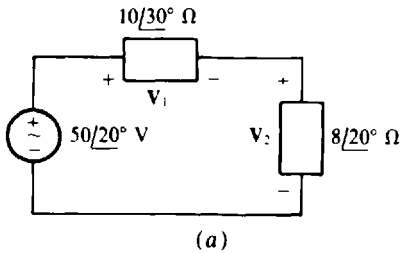

(a)

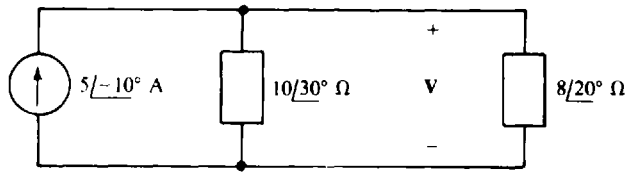

(b)

Fig. 13-13

By voltage division,

$$V_1 = \frac{10/30^\circ}{10/30^\circ + 8/20^\circ} \times 50/20^\circ = \frac{500/50^\circ}{17.9/25.6^\circ} = 27.9/24.4^\circ \text{ V}$$

By KVL,

$$V_2 = 50/20^\circ - 27.9/24.4^\circ = 22.3/14.4^\circ \text{ V}$$

Transformation of the voltage source results in a current source of $(50/20^\circ)/(10/30^\circ) = 5/-10^\circ \text{ A}$ in parallel with a $10/30^\circ\text{-}\Omega$ component, both in parallel with the $8/20^\circ\text{-}\Omega$ component, as shown in Fig. 13-13b. In this parallel circuit, the same voltage V is across all three components. That voltage can be found from the product of the total impedance and the current:

$$V = \frac{(10/30^\circ \parallel 8/20^\circ)}{10/30^\circ + 8/20^\circ} \times 5/-10^\circ = \frac{400/40^\circ}{17.9/25.6^\circ} = 22.3/14.4^\circ \text{ V}$$

Notice that the $8\angle 20^\circ\text{-}\Omega$ component voltage is the same as for the original circuit, but that the $10\angle 30^\circ\text{-}\Omega$ component voltage is different. This result illustrates the fact that a transformed source produces the same voltages and currents outside the source, but usually not inside it.

13.7 Find the mesh currents for the circuit shown in Fig. 13-14.

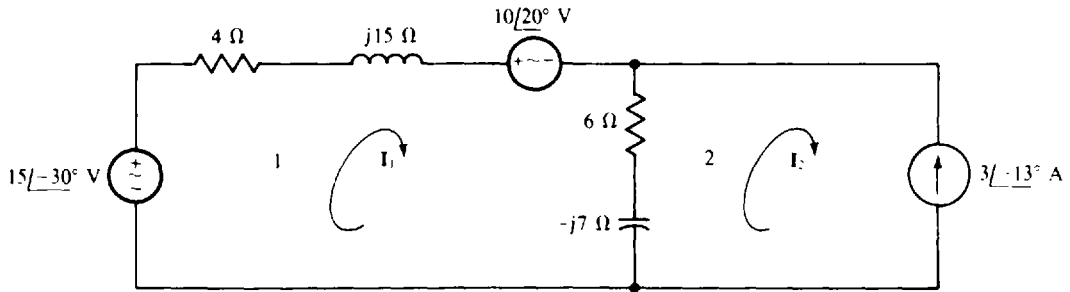

Fig. 13-14

The self-impedance and mutual-impedance approach is almost always best for getting mesh equations. The self-impedance of mesh 1 is $4 + j15 + 6 - j7 = 10 + j8\ \Omega$, and the impedance mutual with mesh 2 is $6 - j7\ \Omega$. The sum of the source voltage rises in the direction of I_1 is $15\angle -30^\circ - 10\angle 20^\circ = 11.5\angle -71.8^\circ\text{ V}$. In this sum the $10\angle 20^\circ\text{-V}$ voltage is subtracted because it is a voltage drop instead of a rise. The mesh 1 equation has, of course, a left-hand side that is the product of the self-impedance and I_1 minus the product of the mutual impedance and I_2 . The right-hand side is the sum of the source voltage rises. Thus, this equation is

$$(10 + j8)I_1 - (6 - j7)I_2 = 11.5\angle -71.8^\circ$$

No KVL equation is needed for mesh 2 because I_2 is the only mesh current through the $3\angle -13^\circ\text{-A}$ current source. As a result, $I_2 = -3\angle -13^\circ\text{ A}$. The initial negative sign is required because I_2 has a positive direction down through the source, but the specified $3\angle -13^\circ\text{-A}$ current is up. Remember that, if for some reason a KVL equation for mesh 2 is wanted, a variable must be included for the voltage across the current source since this voltage is not known.

The substitution of $I_2 = -3\angle -13^\circ\text{ A}$ into the mesh 1 equation produces

$$(10 + j8)I_1 - (6 - j7)(-3\angle -13^\circ) = 11.5\angle -71.8^\circ$$

from which

$$I_1 = \frac{11.5\angle -71.8^\circ + (6 - j7)(-3\angle -13^\circ)}{10 + j8} = \frac{16.4\angle 124.2^\circ}{12.8\angle 38.7^\circ} = 1.28\angle 85.5^\circ\text{ A}$$

Another good analysis approach is to first transform the current source and parallel impedance to an equivalent voltage source and series impedance, and then find I_1 from the resulting single mesh circuit. If this is done, the equation for I_1 will be identical to the one above.

13.8 Solve for the mesh currents I_1 and I_2 in the circuit shown in Fig. 13-15.

The self-impedance and mutual-impedance approach is the best for mesh analysis. The self-impedance of mesh 1 is $8 - j14 + 4 = 12 - j14\ \Omega$, the mutual impedance with mesh 2 is $4\ \Omega$, and the sum of the source voltage rises in the direction of I_1 is $10\angle -40^\circ + 12\angle 10^\circ = 20\angle -12.6^\circ\text{ V}$. So, the mesh 1 KVL equation is

$$(12 - j14)I_1 - 4I_2 = 20\angle -12.6^\circ$$

For mesh 2 the self-impedance is $6 + j10 + 4 = 10 + j10\ \Omega$, the mutual impedance is $4\ \Omega$, and the sum of the voltage rises from voltage sources is $-12\angle 10^\circ\text{ V}$. So, the mesh 2 KVL equation is

$$-4I_1 + (10 + j10)I_2 = -12\angle 10^\circ$$

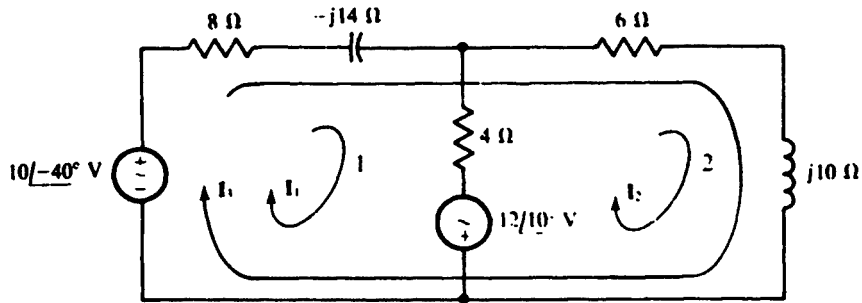

Fig. 13-15

Placing the two mesh equations together shows the symmetry of coefficients (here -4) about the principal diagonal as a result of the common mutual impedance.

$$\begin{aligned} (12 - j14)I_1 - 4I_2 &= 20 \angle -12.6^\circ \\ -4I_1 + (10 + j10)I_2 &= -12 \angle 10^\circ \end{aligned}$$

By Cramer's rule,

$$I_1 = \frac{\begin{vmatrix} 20 \angle -12.6^\circ & -4 \\ -12 \angle 10^\circ & 10 + j10 \end{vmatrix}}{\begin{vmatrix} 12 - j14 & -4 \\ -4 & 10 + j10 \end{vmatrix}} = \frac{(20 \angle -12.6^\circ)(10 + j10) - (-12 \angle 10^\circ)(-4)}{(12 - j14)(10 + j10) - (-4)(-4)} = \frac{239 \angle 36.8^\circ}{245 \angle -4.7^\circ} = 0.974 \angle 41.5^\circ \text{ A}$$

and since I_2 has the same denominator as I_1 ,

$$I_2 = \frac{\begin{vmatrix} 12 - j14 & 20 \angle -12.6^\circ \\ -4 & -12 \angle 10^\circ \end{vmatrix}}{245 \angle -4.7^\circ} = \frac{(12 - j14)(-12 \angle 10^\circ) - (-4)(20 \angle -12.6^\circ)}{245 \angle -4.7^\circ} = -0.63 \angle -48.2^\circ \text{ A}$$

13.9 Use loop analysis to find the current down through the $4\text{-}\Omega$ resistor in the circuit shown in Fig. 13-15.

The preferable selection of loop currents is I_1 and I_3 because then I_1 is the desired current since it is the only current in the $4\text{-}\Omega$ resistor and has a downward direction. Of course, the self-impedance and mutual-impedance approach should be used.

The self-impedance of the I_1 loop is $8 - j14 + 4 = 12 - j14 \Omega$, the mutual impedance with the I_3 loop is $8 - j14 \Omega$, and the sum of the source voltage rises in the direction of I_1 is $10 \angle -40^\circ + 12 \angle 10^\circ = 20 \angle -12.6^\circ \text{ V}$. The self-impedance of the I_3 loop is $8 - j14 + 6 + j10 = 14 - j4 \Omega$, of which $8 - j14 \Omega$ is mutual with the I_1 loop. The source voltage rise in the direction of I_3 is $10 \angle -40^\circ \text{ V}$. Therefore, the loop equations are

$$\begin{aligned} (12 - j14)I_1 + (8 - j14)I_3 &= 20 \angle -12.6^\circ \\ (8 - j14)I_1 + (14 - j4)I_3 &= 10 \angle -40^\circ \end{aligned}$$

The mutual terms are positive because the I_1 and I_3 loop currents have the same direction through the mutual impedance.

By Cramer's rule,

$$I_1 = \frac{\begin{vmatrix} 20 \angle -12.6^\circ & 8 - j14 \\ 10 \angle -40^\circ & 14 - j4 \end{vmatrix}}{\begin{vmatrix} 12 - j14 & 8 - j14 \\ 8 - j14 & 14 - j4 \end{vmatrix}} = \frac{(20 \angle -12.6^\circ)(14 - j4) - (10 \angle -40^\circ)(8 - j14)}{(12 - j14)(14 - j4) - (8 - j14)(8 - j14)} = \frac{285 \angle 4^\circ}{245 \angle -4.7^\circ} = 1.16 \angle 8.7^\circ \text{ A}$$

As a check, notice that this loop current should be equal to the difference in the mesh currents I_1 and I_2 found in the solution to Prob. 13.8. It is, since $I_1 - I_2 = 0.974 \angle 41.5^\circ - (-0.63 \angle -48.2^\circ) = 1.16 \angle 8.7^\circ \text{ A}$.

13.10 Find the mesh currents for the circuit shown in Fig. 13-16a.

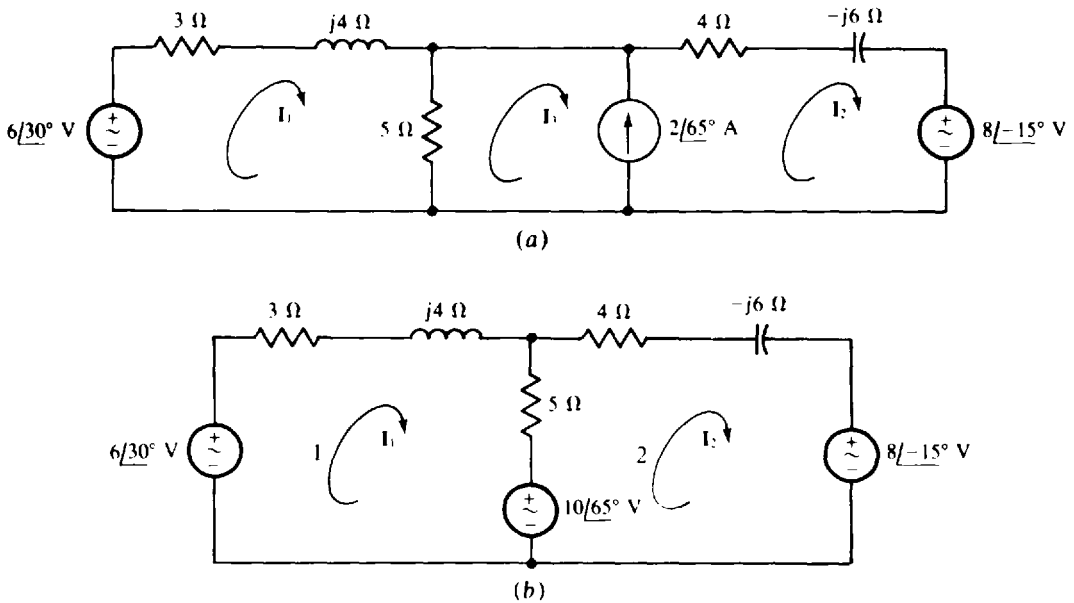

Fig. 13-16

A good first step is to transform the $2\angle 65^\circ$ A current source and parallel $5\text{-}\Omega$ resistor into a voltage source and series resistor, as shown in the circuit of Fig. 13-16b. Note that this transformation eliminates mesh 3. The self-impedance of mesh 1 is $3 + j4 + 5 = 8 + j4\ \Omega$, and that of mesh 2 is $4 - j6 + 5 = 9 - j6\ \Omega$. The mutual impedance is $5\ \Omega$. The sum of the voltage rises from sources is $6\angle 30^\circ - 10\angle 65^\circ = 6.14\angle -80.9^\circ$ V for mesh 1 and $10\angle 65^\circ - 8\angle -15^\circ = 11.7\angle 107^\circ$ V for mesh 2. The corresponding mesh equations are

$$\begin{aligned} (8 + j4)I_1 - 5I_2 &= 6.14\angle -80.9^\circ \\ -5I_1 + (9 - j6)I_2 &= 11.7\angle 107^\circ \end{aligned}$$

In matrix form these are

$$\begin{bmatrix} 8 + j4 & -5 \\ -5 & 9 - j6 \end{bmatrix} \begin{bmatrix} I_1 \\ I_2 \end{bmatrix} = \begin{bmatrix} 6.14\angle -80.9^\circ \\ 11.7\angle 107^\circ \end{bmatrix}$$

These equations are best solved using a scientific calculator (or a computer). The solutions obtained are $I_1 = 0.631\angle -164.4^\circ = -0.631\angle 15.6^\circ$ A and $I_2 = 1.13\angle 156.1^\circ = -1.13\angle -23.9^\circ$ A.

From the original circuit shown in Fig. 13-16a, the current in the current source is $I_2 - I_3 = 2\angle 65^\circ$ A. Consequently,

$$I_3 = I_2 - 2\angle 65^\circ = -1.13\angle -23.9^\circ - 2\angle 65^\circ = 2.31\angle -144.1^\circ = -2.31\angle 35.9^\circ$$

13.11 Use loop analysis to solve for the current flowing down through the $5\text{-}\Omega$ resistor in the circuit shown in Fig. 13-16a.

Because this circuit has three meshes, the analysis requires three loop currents. The loops can be selected as in Fig. 13-17 with only one current I_1 flowing through the $5\text{-}\Omega$ resistor so that only one current needs to be solved for. Also, preferably only one loop current should flow through the current source.

The self-impedance of the I_1 loop is $3 + j4 + 5 = 8 + j4\ \Omega$, the impedance mutual with the I_2 loop is $3 + j4\ \Omega$, and the aiding source voltage is $6\angle 30^\circ$ V. So, the loop 1 equation is

$$(8 + j4)I_1 + (3 + j4)I_2 = 6\angle 30^\circ$$

The I_2 coefficient is positive because I_2 and I_1 have the same direction through the mutual components.

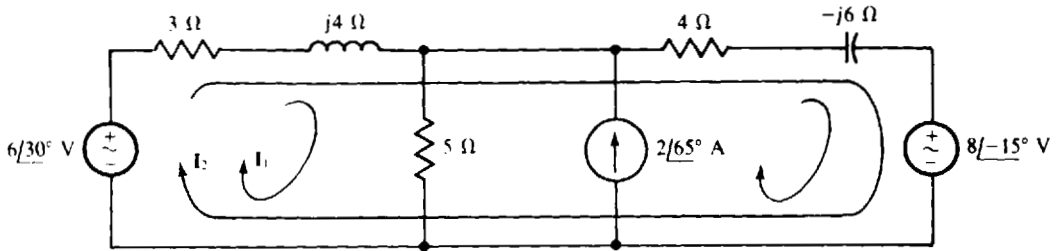

Fig. 13-17

For the second loop, the self-impedance is $3 + j4 + 4 - j6 = 7 - j2\ \Omega$, of which $3 + j4\ \Omega$ is mutual with loop 1. The $2\angle 65^\circ$ -A current flowing through the components of $4 - j6\ \Omega$ produces a voltage drop of $(4 - j6)(2\angle 65^\circ) = 14.4\angle 8.69^\circ$ V that has the same effect as the voltage from an opposing voltage source. In addition, the voltage sources have a net aiding voltage of $6\angle 30^\circ - 8\angle -15^\circ = 5.67\angle 117^\circ$ V. The resulting loop 2 equation is

$$(3 + j4)I_1 + (7 - j2)I_2 = 5.67\angle 117^\circ - 14.4\angle 8.69^\circ = 17\angle 170^\circ$$

In matrix form these equations are

$$\begin{bmatrix} 8 + j4 & 3 + j4 \\ 3 + j4 & 7 - j2 \end{bmatrix} \begin{bmatrix} I_1 \\ I_2 \end{bmatrix} = \begin{bmatrix} 6\angle 30^\circ \\ 17\angle 170^\circ \end{bmatrix}$$

A scientific calculator can be used to obtain $I_1 = 1.74\angle 43.1^\circ$ A from these equations.

As a check, this loop current I_1 should be equal to the difference in the mesh currents I_1 and I_3 found in the solution to Prob. 13.10. It is, since $I_1 - I_3 = -0.631\angle 15.6^\circ - (-2.31\angle 35.9^\circ) = 1.74\angle 43.1^\circ$ A.

13.12 Use mesh analysis to solve for the currents in the circuit of Fig. 13-18.

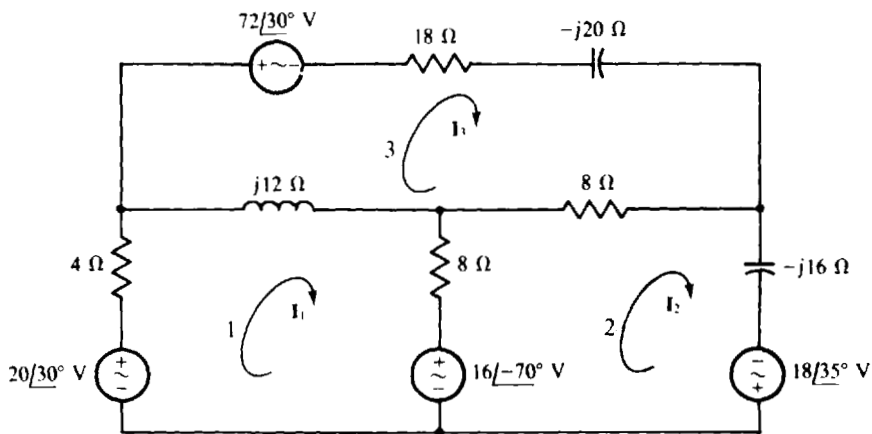

Fig. 13-18

The self-impedances are $4 + j12 + 8 = 12 + j12\ \Omega$ for mesh 1, $8 + 8 - j16 = 16 - j16\ \Omega$ for mesh 2, and $18 - j20 + 8 + j12 = 26 - j8\ \Omega$ for mesh 3. The mutual impedances are $8\ \Omega$ for meshes 1 and 2, $8\ \Omega$ for meshes 2 and 3, and $j12\ \Omega$ for meshes 1 and 3. The sum of the aiding source voltages is $20\angle 30^\circ - 16\angle -70^\circ = 27.7\angle 64.7^\circ$ V for mesh 1, $16\angle -70^\circ + 18\angle 35^\circ = 20.8\angle -13.1^\circ$ V for mesh 2, and $-72\angle 30^\circ$ V for mesh 3. In matrix form, the mesh equations are

$$\begin{bmatrix} 12 + j12 & -8 & -j12 \\ -8 & 16 - j16 & -8 \\ -j12 & -8 & 26 - j8 \end{bmatrix} \begin{bmatrix} I_1 \\ I_2 \\ I_3 \end{bmatrix} = \begin{bmatrix} 27.7\angle 64.7^\circ \\ 20.8\angle -13.1^\circ \\ -72\angle 30^\circ \end{bmatrix}$$

The solutions, which are best obtained by using a calculator or computer, are

$$\mathbf{I}_1 = 2.07\angle -26.6^\circ \text{ A} \quad \mathbf{I}_2 = 1.38\angle 7.36^\circ \text{ A} \quad \text{and} \quad \mathbf{I}_3 = 1.55\angle -146^\circ \text{ A}$$

13.13 Show a circuit that corresponds to the following mesh equations:

$$\begin{aligned} (17 - j4)\mathbf{I}_1 - (11 + j5)\mathbf{I}_2 &= 6/30 \\ -(11 + j5)\mathbf{I}_1 + (18 + j7)\mathbf{I}_2 &= -8/30 \end{aligned}$$

Because there are two equations, the circuit has two meshes: mesh 1 for which \mathbf{I}_1 is the principal mesh current, and mesh 2 for which \mathbf{I}_2 is the principal mesh current. The $-(11 + j5)$ coefficients indicate that meshes 1 and 2 have a mutual impedance of $11 + j5 \Omega$ which could be from an $11\text{-}\Omega$ resistor in series with an inductor that has a reactance of 5Ω . In the first equation the \mathbf{I}_1 coefficient indicates that the resistors in mesh 1 have a total resistance of 17Ω . Since 11Ω of this is in the mutual impedance, there is $17 - 11 = 6 \Omega$ of resistance in mesh 1 that is not mutual. The $-j4$ of the \mathbf{I}_1 coefficient indicates that mesh 1 has a total reactance of -4Ω . Since the mutual branch has a reactance of 5Ω , the remainder of mesh 1 must have a reactance of $-4 - 5 = -9 \Omega$, which can be from a single capacitor. The $6/30$ on the right-hand side of the mesh 1 equation is the result of a total of $6/30 \text{ V}$ of voltage source rises (aiding source voltages). One way to obtain this is with a single source $6/30 \text{ V}$ that is not in the mutual branch and that has a polarity such that \mathbf{I}_1 flows out of its positive terminal.

Similarly, from the second equation, mesh 2 has a nonmutual resistance of $18 - 11 = 7 \Omega$ that can be from a resistor that is not in the mutual branch. And from the $j7$ part of the \mathbf{I}_2 coefficient, mesh 2 has a total reactance of 7Ω . Since 5Ω of this is in the mutual branch, there is $7 - 5 = 2 \Omega$ remaining that could be from a single inductor that is not in the mutual branch. The $-8/30$ on the right-hand side is the result of a total of $8/30 \text{ V}$ of voltage source drops (opposing source voltages). One way to obtain this is with a single source of $8/30 \text{ V}$ that is not in the mutual branch and that has a polarity such that \mathbf{I}_2 flows into its positive terminal.

Figure 13-19 shows the corresponding circuit. This is just one of an infinite number of circuits from which the equations could have been written.

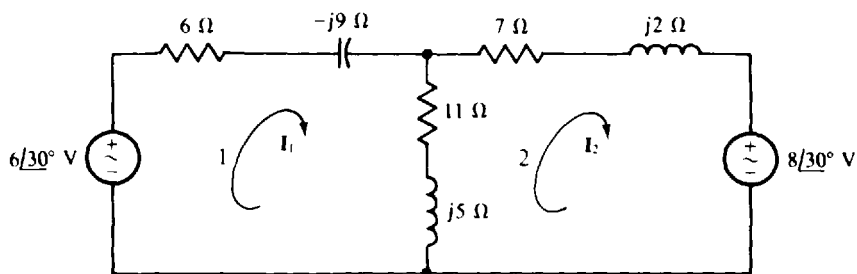

Fig. 13-19

13.14 Use loop analysis to solve for the current flowing to the right through the $6\text{-}\Omega$ resistor in the circuit shown in Fig. 13-20.

Three loop currents are required because the circuit has three meshes. Only one of the loop currents should flow through the $6\text{-}\Omega$ resistor so that only one current has to be solved for. This current is \mathbf{I}_2 , as shown. The paths for the two other loop currents can be selected as shown, but there are other suitable paths.

It is relatively easy to put these equations into matrix form. The loop self-impedances and mutual impedances can be used to fill in the coefficient matrix. And the elements for the source vector are $100/20 \text{ V}$ for loop 1 and 0 V for the two other loops. Thus, the equations in matrix form are

$$\begin{bmatrix} 8 - j2 & j12 & j2 \\ j12 & 6 - j20 & -j20 \\ j2 & -j20 & 16 - j10 \end{bmatrix} \begin{bmatrix} \mathbf{I}_1 \\ \mathbf{I}_2 \\ \mathbf{I}_3 \end{bmatrix} = \begin{bmatrix} 100/20 \\ 0 \\ 0 \end{bmatrix}$$

The solutions, which are best obtained from a calculator or computer, include $\mathbf{I}_2 = 3.62\angle -45.8^\circ \text{ A}$.

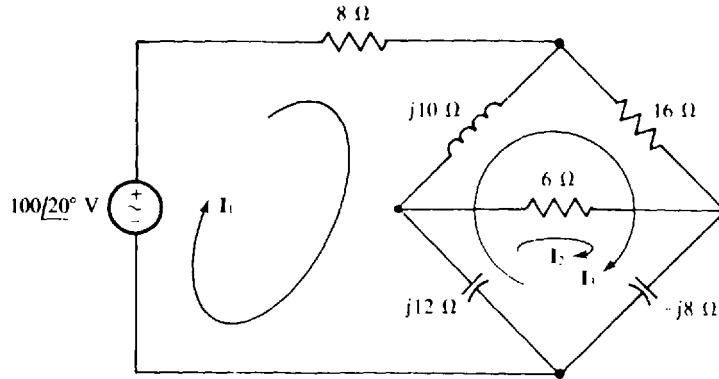

Fig. 13-20

13.15 Solve for the node voltages in the circuit shown in Fig. 13-21.

Using self-admittances and mutual admittances is almost always best for obtaining the nodal equations. The self-admittance of node 1 is

$$\frac{1}{0.25} + \frac{1}{j0.5} = 4 - j2 \text{ S}$$

of which 4 S is mutual conductance. The sum of the currents from current sources into node 1 is $20/10 + 15/∠-30 = 32.9/∠-7.02$ A. So, the node 1 KCL equation is

$$(4 - j2)V_1 - 4V_2 = 32.9 - j7.02$$

No KCL equation is needed for node 2 because a grounded voltage source is connected to it, making $V_2 = -12/∠-15$ V. If, however, for some reason a KCL equation is wanted for node 2, a variable has to be introduced for the current through the voltage source because this current is unknown. Note that, because the voltage source does not have a series impedance, it cannot be transformed to a current source with the source transformation techniques presented in this chapter.

The substitution of $V_2 = -12/∠-15$ into the node 1 equation results in

$$(4 - j2)V_1 - 4(-12/∠-15) = 32.9 - j7.02$$

from which $V_1 = \frac{32.9/∠-7.02 - 48/∠-15}{4 - j2} = \frac{16.05/∠148}{4.47/∠-27} = 3.59/∠175 = 3.59/∠-5$ A

13.16 Find the node voltages in the circuit shown in Fig. 13-22.

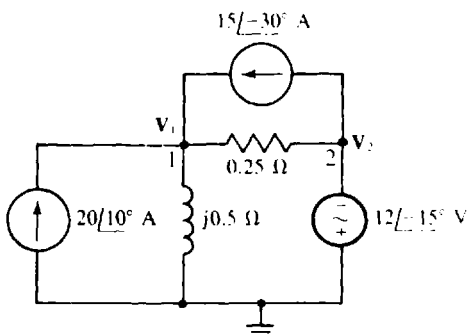

Fig. 13-21

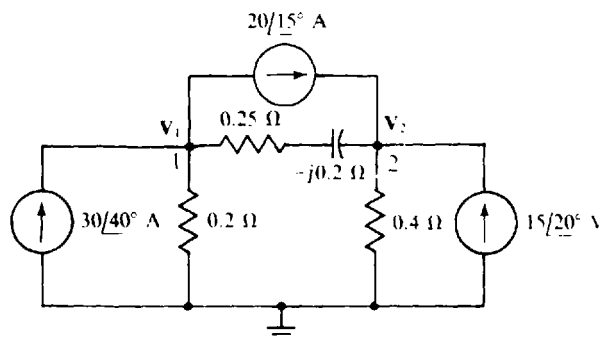

Fig. 13-22

The self-admittance of node 1 is

$$\frac{1}{0.2} + \frac{1}{0.25 - j0.2} = 5 + 2.44 + j1.95 = 7.69/14.7 \text{ S}$$

of which $2.44 + j1.95 = 3.12/38.7 \text{ S}$ is mutual admittance. The sum of the currents into node 1 from current sources is $30/40 - 20/15 = 14.6/75.4 \text{ A}$. Therefore, the node 1 KCL equation is

$$(7.69/14.7) V_1 - (3.12/38.7) V_2 = 14.6/75.4$$

The self-admittance of node 2 is

$$\frac{1}{0.4} + \frac{1}{0.25 - j0.2} = 2.5 + 2.44 + j1.95 = 5.31/21.6 \text{ S}$$

of which $3.12/38.7 \text{ S}$ is mutual admittance. The sum of the currents into node 2 from current sources is $20/15 + 15/20 = 35.0/17.1 \text{ A}$. The result is a node 2 KCL equation of

$$-(3.12/38.7) V_1 + (5.31/21.6) V_2 = 35.0/17.1$$

In matrix form these equations are

$$\begin{bmatrix} 7.69/14.7 & -3.12/38.7 \\ -3.12/38.7 & 5.31/21.6 \end{bmatrix} \begin{bmatrix} V_1 \\ V_2 \end{bmatrix} = \begin{bmatrix} 14.6/75.4 \\ 35.0/17.1 \end{bmatrix}$$

The solutions, which are easily obtained with a scientific calculator, are $V_1 = 5.13/47.3 \text{ V}$ and $V_2 = 8.18/15.7 \text{ V}$.

13.17 Use nodal analysis to find V for the circuit shown in Fig. 13-23.

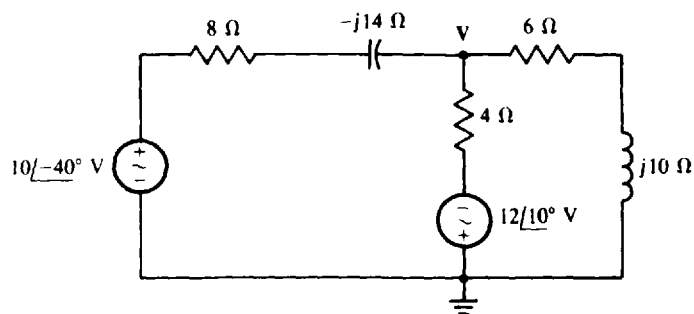

Fig. 13-23

Although a good approach is to transform both voltage sources to current sources, this transformation is not essential because both voltage sources are grounded. (Actually, source transformations are never absolutely necessary.) Leaving the circuit as it stands and summing currents away from the V node in the form of voltages divided by impedances gives the equation of

$$\frac{V - 10\angle-40^\circ}{8 - j14} + \frac{V - (-12\angle10^\circ)}{4} + \frac{V}{6 + j10} = 0$$

The first term is the current flowing to the left through the $8 - j14 \Omega$ components, the second is the current flowing down through the $4\text{-}\Omega$ resistor, and the third is the current flowing to the right through the $6 + j10 \Omega$ components.

This equation simplifies to

$$(0.062/60.3 + 0.25 + 0.0857/\angle-59) V = 0.62/20.3 - 3/10$$

Further simplification reduces the equation to

$$(0.325/-3.47) \text{ V} = 2.392/-173$$

from which
$$\text{V} = \frac{2.392/-173}{0.325/-3.47} = 7.35/-169.2 = -7.35/10.8 \text{ V}$$

Incidentally, this result can be checked since the circuit shown in Fig. 13-23 is the same as that shown in Fig. 13-15 for which, in the solution to Prob. 13.9, the current down through the 4-Ω resistor was found to be $1.16/8.7^\circ \text{ A}$. The voltage V across the center branch can be calculated from this current: $\text{V} = 4(1.16/8.7^\circ) - 12/10^\circ = -7.35/10.8^\circ \text{ V}$, which checks.

13.18 Find the node voltages in the circuit shown in Fig. 13-24a.

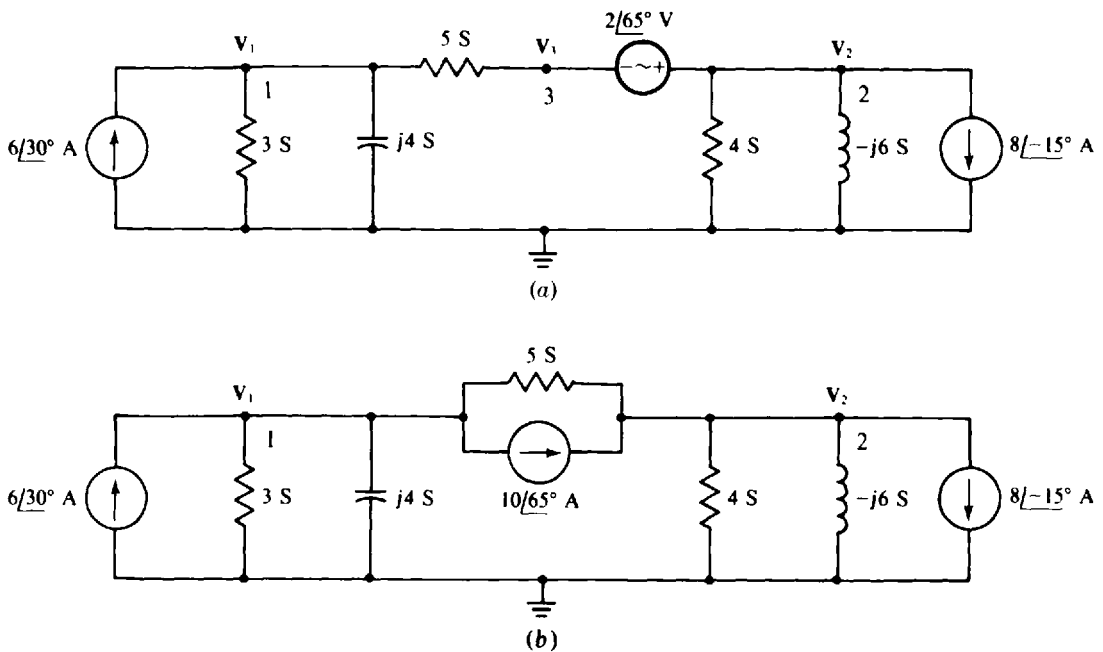

Fig. 13-24

Since the voltage source does not have a grounded terminal, a good first step for nodal analysis is to transform this source and the series resistor to a current source and parallel resistor, as shown in Fig. 13-24b. Note that this transformation eliminates node 3. In the circuit shown in Fig. 13-24b, the self-admittance of node 1 is $3 + j4 + 5 = 8 + j4 \text{ S}$, and that of node 2 is $5 + 4 - j6 = 9 - j6 \text{ S}$. The mutual admittance is 5 S . The sum of the currents into node 1 from current sources is $6/30^\circ - 10/65^\circ = 6.14/-80.9^\circ \text{ A}$, and that into node 2 is $10/65^\circ - 8/-15^\circ = 11.7/107^\circ \text{ A}$. Thus, the corresponding nodal equations are

$$\begin{aligned} (8 + j4)V_1 - 5V_2 &= 6.14/-80.9^\circ \\ -5V_1 + (9 - j6)V_2 &= 11.7/107^\circ \end{aligned}$$

Except for having V 's instead of I 's, these are the same equations as for Prob. 13.10. Consequently, the answers are numerically the same: $V_1 = -0.631/15.6^\circ \text{ V}$, and $V_2 = -1.13/-23.9^\circ \text{ V}$.

From the original circuit shown in Fig. 13-24a, the voltage at node 3 is $2/65^\circ \text{ V}$ more negative than the voltage at node 2. So,

$$V_3 = V_2 - 2/65^\circ = -1.13/-23.9^\circ - 2/65^\circ = 2.31/-144.1^\circ = -2.31/35.9^\circ \text{ V}$$

13.19 Calculate the node voltages in the circuit of Fig. 13-25.

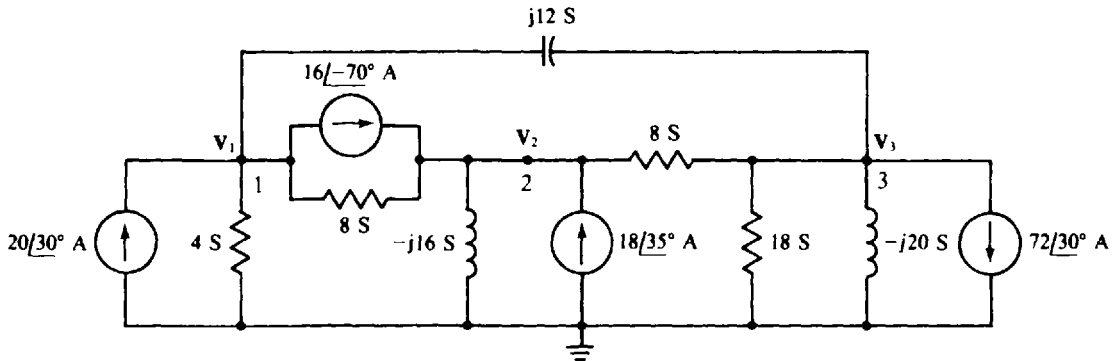

Fig. 13-25

The self-admittances are $4 + 8 + j12 = 12 + j12$ S for node 1, $8 - j16 + 8 = 16 - j16$ S for node 2, and $8 + 18 - j20 + j12 = 26 - j8$ S for node 3. The mutual admittances are 8 S for nodes 1 and 2, $j12$ S for nodes 1 and 3, and 8 S for nodes 2 and 3. The currents flowing into the nodes from current sources are $20\angle30^\circ - 16\angle-70^\circ = 27.7\angle64.7^\circ$ A for node 1, $16\angle-70^\circ + 18\angle35^\circ = 20.8\angle-13.1^\circ$ A for node 2, and $-72\angle30^\circ$ A for node 3. So, the nodal equations are

$$\begin{aligned} (12 + j12)V_1 - 8V_2 - j12V_3 &= 27.7\angle64.7^\circ \\ -8V_1 + (16 - j16)V_2 - 8V_3 &= 20.8\angle-13.1^\circ \\ -j12V_1 - 8V_2 + (26 - j8)V_3 &= -72\angle30^\circ \end{aligned}$$

Except for having V 's instead of I 's, this set of equations is the same as that for Prob. 13.12. So, the answers are numerically the same: $V_1 = 2.07\angle-26.6^\circ$ V, $V_2 = 1.38\angle7.36^\circ$ V, and $V_3 = 1.55\angle-146^\circ$ V.

13.20 Show a circuit corresponding to the nodal equations

$$\begin{aligned} (8 + j6)V_1 - (3 - j4)V_2 &= 4 + j2 \\ -(3 - j4)V_1 + (11 - j6)V_2 &= -6\angle-50^\circ \end{aligned}$$

Since there are two equations, the circuit has three nodes, one of which is the ground or reference node, and the others of which are nodes 1 and 2. The circuit admittances can be found by starting with the mutual admittance. From the $-(3 - j4)$ coefficients, nodes 1 and 2 have a mutual admittance of $3 - j4$ S, which can be from a resistor and inductor connected in parallel between nodes 1 and 2. The $8 + j6$ coefficient of V_1 in the first equation is the self-admittance of node 1. Since $3 - j4$ S of this is in mutual admittance, there must be components connected between node 1 and ground that have a total of $8 + j6 - (3 - j4) = 5 + j10$ S of admittance. This can be from a resistor and parallel capacitor. Similarly, from the second equation, components connected between node 2 and ground have a total admittance of $11 - j6 - (3 - j4) = 8 - j2$ S. This can be from a resistor and parallel inductor.

The $4 + j2$ on the right-hand side of the first equation can be from a total current of $4 + j2 = 4.47\angle26.6^\circ$ A entering node 1 from current sources. The easiest way to obtain this is with a single current source connected between node 1 and ground with the source arrow directed into node 1. Similarly, from the second equation, the $-6\angle-50^\circ$ can be from a single current source of $6\angle-50^\circ$ A connected between node 2 and ground with the source arrow directed away from node 2 because of the initial negative sign in $-6\angle-50^\circ$.

The resulting circuit is shown in Fig. 13-26.

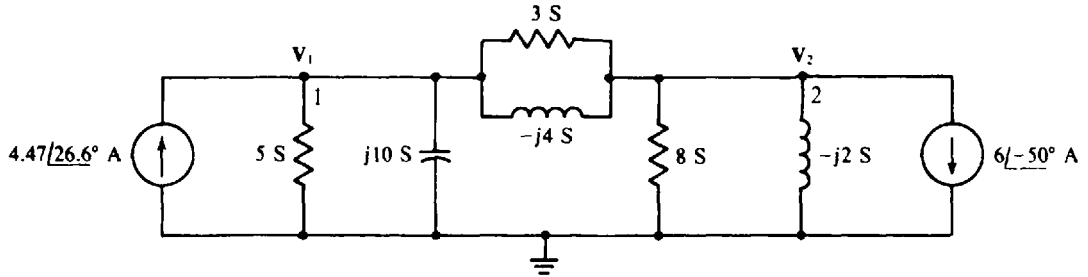

Fig. 13-26

13.21 For the circuit shown in Fig. 13-27, which contains a transistor model, first find V as a function of I . Then, find V as a numerical value.

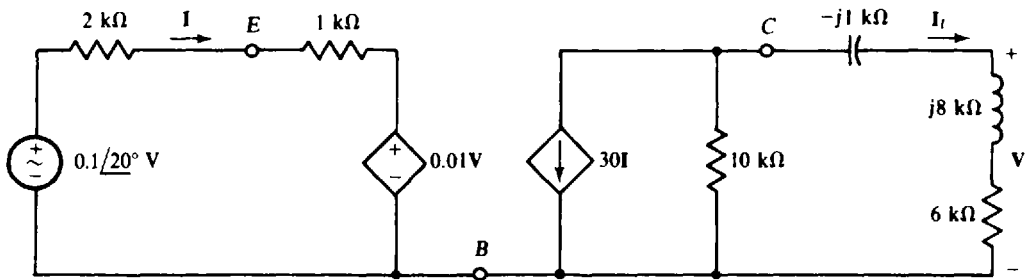

Fig. 13-27

In the right-hand section of the circuit, the current I_L is, by current division,

$$I_L = - \frac{10^4}{10\,000 + 6000 + j8000 - j1000} \times 30I = \frac{-3 \times 10^5 I}{17.46 \times 10^3 / 23.6^\circ} = -(17.2 / -23.6^\circ) I$$

And, by Ohm's law,

$$V = (6000 + j8000)I_L = (10^4 / 53.1^\circ)(-17.2 / -23.6^\circ)I = (-17.2 \times 10^4 / 29.5^\circ)I$$

which shows that the magnitude of V is 17.2×10^4 times that of I , and the angle of V is $29.5^\circ - 180^\circ = -150.5^\circ$ plus that of I . (The -180° is from the negative sign.)

If this value of V is used in the 0.01-V expression of the dependent source in the left-hand section of the circuit, and then KVL applied, the result is

$$2000I + 1000I + 0.01(-17.2 \times 10^4 / 29.5^\circ)I = 0.1 / 20^\circ$$

from which

$$I = \frac{0.1 / 20^\circ}{2000 + 1000 - 17.2 \times 10^2 / 29.5^\circ} = \frac{0.1 / 20^\circ}{1.73 \times 10^3 / -29.3^\circ} = 5.79 \times 10^{-5} / 49.3^\circ \text{ A}$$

This, substituted into the equation for V , gives

$$V = (-17.2 \times 10^4 / 29.5^\circ)(5.79 \times 10^{-5} / 49.3^\circ) = -9.95 / 78.8^\circ \text{ V}$$

13.22 Solve for I in the circuit shown in Fig. 13-28.

What analysis method is best for this circuit? A brief consideration of the circuit shows that two equations are necessary whether mesh, loop, or nodal analysis is used. Arbitrarily, nodal analysis will be

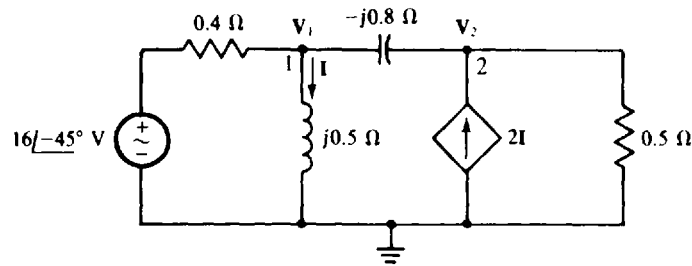

Fig. 13-28

used to find V_1 , and then I will be found from V_1 . For nodal analysis, the voltage source and series resistor are preferably transformed to a current source with parallel resistor. The current source has a current of $(16\angle-45^\circ)/0.4 = 40\angle-45^\circ$ A directed into node 1, and the parallel resistor has a resistance of 0.4Ω .

The self-admittances are

$$\frac{1}{0.4} + \frac{1}{j0.5} + \frac{1}{-j0.8} = 2.5 - j0.75 \text{ S}$$

for node 1, and

$$\frac{1}{0.5} + \frac{1}{-j0.8} = 2 + j1.25 \text{ S}$$

for node 2. The mutual admittance is $1/(-j0.8) = j1.25$ S.

The controlling current I in terms of V_1 is $I = V_1/j0.5 = -j2V_1$, which means that $2I = -j4V_1$ is the current into node 2 from the dependent current source.

From the admittances and the source currents, the nodal equations are

$$\begin{aligned} (2.5 - j0.75)V_1 - j1.25V_2 &= 40\angle-45^\circ \\ -j1.25V_1 + (2 + j1.25)V_2 &= -j4V_1 \end{aligned}$$

which, with $j4V_1$ added to both sides of the second equation, simplify to

$$\begin{aligned} (2.5 - j0.75)V_1 - j1.25V_2 &= 40\angle-45^\circ \\ j2.75V_1 + (2 + j1.25)V_2 &= 0 \end{aligned}$$

The lack of symmetry of the coefficients about the principal diagonal and the lack of an initial negative sign for the V_1 term in the second equation are caused by the action of the dependent source.

If a calculator is used to solve for V_1 , the result is $V_1 = 31.64\angle-46.02^\circ$ V. Finally,

$$I = \frac{V_1}{j0.5} = \frac{31.64\angle-46.02^\circ}{0.5\angle90^\circ} = 63.3\angle-136^\circ = -63.3\angle44^\circ \text{ A}$$

13.23 Use PSpice to obtain the mesh currents in the circuit of Fig. 13-18 of Prob. 13.12.

The first step is to obtain a corresponding PSpice circuit. Since no frequency is specified in Prob. 13.12 (or even if one was), a convenient frequency can be assumed and then used in calculating the inductances and capacitances from the specified inductive and capacitive impedances. Usually, $\omega = 1$ rad/s is the most convenient. For this frequency, the inductor that has an impedance of $j12 \Omega$ has an inductance of $12/1 = 12$ H. The capacitor that has an impedance of $-j20 \Omega$ has a capacitance of $1/20 = 0.05$ F, as should be apparent. And the capacitor that has an impedance of $-j16 \Omega$ has a capacitance of $1/16 = 0.0625$ F.

Figure 13-29 shows the corresponding PSpice circuit. For convenience, the voltage-source voltages remain specified in phasor form, and the mesh currents are shown as phasor variables. Thus, Fig. 13-29 is really a mixture of a time-domain and phasor-domain circuit diagram.

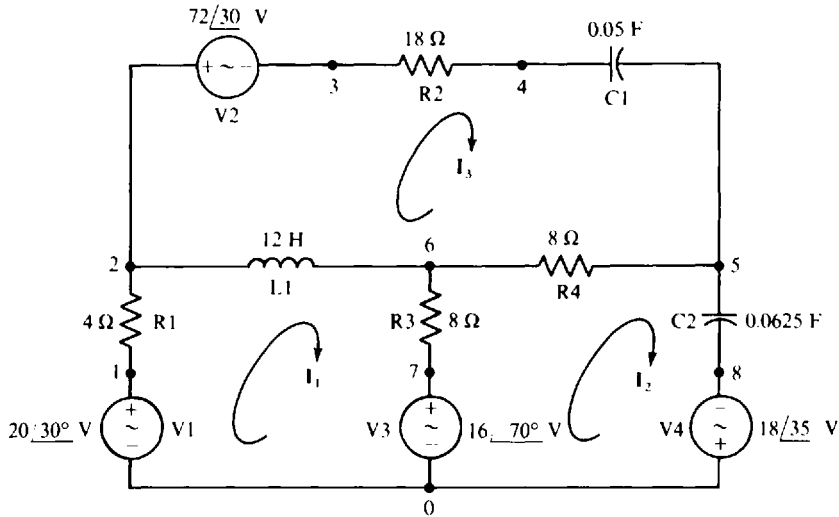

Fig. 13-29

In the circuit file the frequency must be specified in hertz, which for 1 rad/s is $1/2\pi = 0.159155$ Hz. The circuit file corresponding to the PSpice circuit of Fig. 13-29 is as follows:

CIRCUIT FILE FOR THE CIRCUIT OF FIG. 13-29

```
V1 1 0 AC 20 30
R1 1 2 4
V2 2 3 AC 72 30
R2 3 4 18
C1 4 5 0.05
L1 2 6 12
R3 6 7 8
V3 7 0 AC 16 -70
R4 6 5 8
C2 5 8 0.0625
V4 0 8 AC 18 35
.AC LIN 1 0.159155 0.159155
.PRINT AC IM(R1) IP(R1) IM(C2) IP(C2) IM(R2) IP(R2)
.END
```

When this circuit file is run with PSpice, the output file will contain the following results.

FREQ	IM(R1)	IP(R1)	IM(C2)	IP(C2)	IM(R2)
1.592E-01	2.066E+00	-2.660E+01	1.381E+00	7.356E+00	1.550E+00
FREQ	IP(R2)				
1.592E-01	-1.458E+02				

The answers $I_1 = 2.066/-26.60$ A, $I_2 = 1.381/7.356$ A, and $I_3 = 1.550/-145.8$ A agree within three significant digits with the answers to Prob. 13.12.

13.24 Calculate V_o in the circuit of Fig. 13-30.

By nodal analysis,

$$\frac{V_1 - 30\angle -46}{20} + \frac{V_1 - 3V_o}{14} + \frac{V_1 - V_o}{-j16} = 0 \quad \text{and} \quad \frac{V_o - V_1}{-j16} + 2I + \frac{V_o}{10} + \frac{V_o}{-j8} = 0$$

Also

$$I = \frac{V_1 - 3V_o}{14}$$

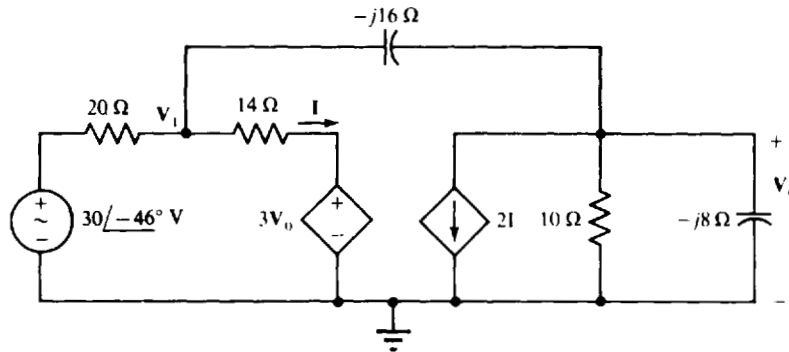

Fig. 13-30

Substituting from the third equation into the second and multiplying both resulting equations by 280 gives

$$\begin{aligned}(34 + j17.5)V_1 - (60 + j17.5)V_o &= 420\angle -46^\circ \\ (40 - j17.5)V_1 + (-92 + j52.5)V_o &= 0\end{aligned}$$

Use of Cramer's rule or a scientific calculator provides the solution $V_o = 13.56\angle -77.07^\circ$ V.

13.25 Repeat Prob. 13.24 using PSpice.

For a PSpice circuit file, capacitances are required instead of the capacitive impedances that are specified in the circuit of Fig. 13-30. It is often convenient to assume a frequency of $\omega = 1$ rad/s to obtain these capacitances. Then, of course, $f = 1/2\pi = 0.159155$ Hz is the frequency that must be specified in the circuit file. For $\omega = 1$ rad/s, the capacitor that has an impedance of $-j16 \Omega$ has a capacitance of $1/16 = 0.0625$ F, and the capacitor that has an impedance of $-j8 \Omega$ has a capacitance of $1/8 = 0.125$ F. Figure 13.31 shows the PSpice circuit that corresponds to the phasor-domain circuit of Fig. 13-30. The V2 dummy source is required to obtain the controlling current for the F1 current-controlled current source.

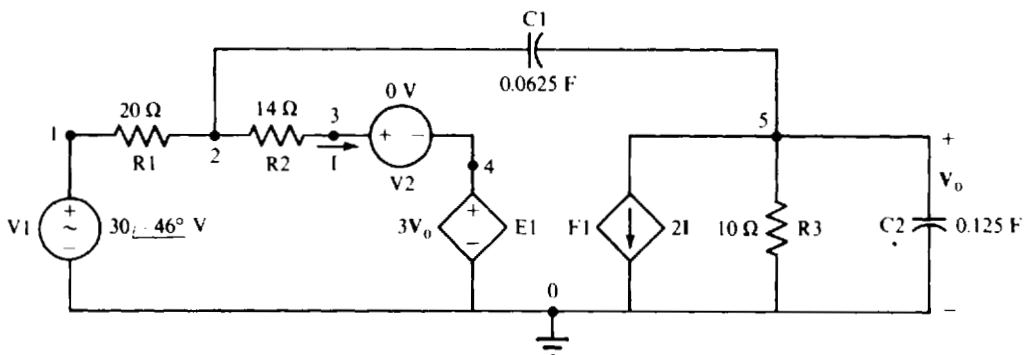

Fig. 13-31

The corresponding circuit file is

```
CIRCUIT FILE FOR THE CIRCUIT OF FIG. 13-31
V1 1 0 AC 30 -46
R1 1 2 20
R2 2 3 14
V2 3 4
E1 4 0 5 0 3
C1 2 5 0.0625
F1 5 0 V2 2
R3 5 0 10
C2 5 0 0.125
.AC LIN 1 0.159155 0.159155
.PRINT AC VM(5) VP(5)
.END
```

When this circuit file is run with PSpice, the output file includes

FREQ	VM(5)	VP(5)
1.592E-01	1.356E+01	-7.707E+01

from which $V_o = 13.56 \angle -77.07^\circ$ V, which is in complete agreement with the answer to Prob. 13.24.

13.26 Use PSpice to determine v_o in the circuit of Fig. 12-25a of Prob. 12.47.

Figure 13-32 is the PSpice circuit corresponding to the circuit of Fig. 12-25a. The op amp has been deleted and a voltage-controlled voltage source E1 inserted at what was the op-amp output. This source is, of course, a model for the op amp. Also, a large resistor R1 has been inserted from node 1 to node 0 to satisfy the PSpice requirement for at least two components connected to each node.

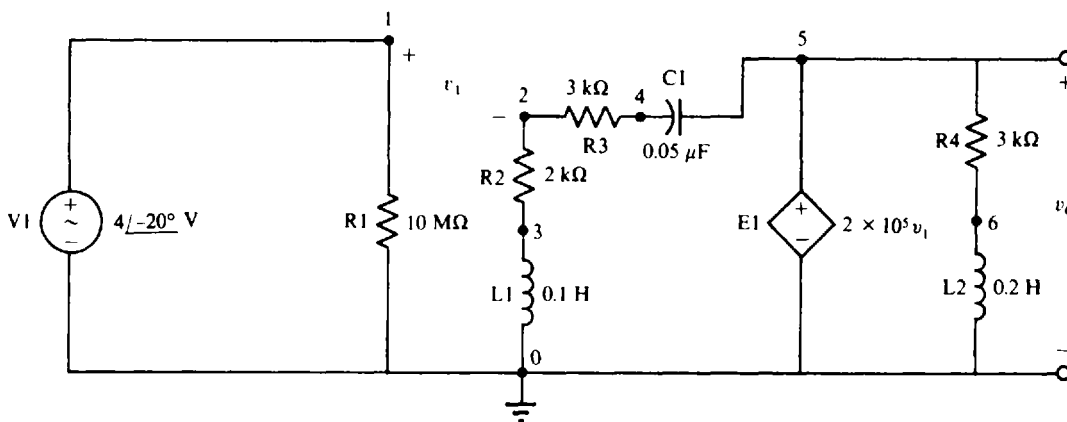

Fig. 13-32

Following is the circuit file. The specified frequency, 1591.55 Hz, is equal to the source frequency of 10 000 rad/s divided by 2π . Also shown is the output obtained when this circuit file is run with PSpice. The answer of $V(5) = 9.121 \angle -57.87^\circ$ V is the phasor for

$$v_o = 9.121 \sin(10\,000t - 57.87^\circ) \text{ V,}$$

which agrees within three significant digits with the v_o answer of Prob. 12.47.

CIRCUIT FILE FOR THE CIRCUIT OF FIG. 13-32

```
V1 1 0 AC 4 -20
R1 1 0 10MEG
R2 2 3 2K
L1 3 0 0.1
R3 2 4 3K
C1 4 5 0.05U
E1 5 0 1 2 2E5
R4 5 6 3K
L2 6 0 0.2
.AC LIN 1 1591.55 1591.55
.PRINT AC VM(5) VP(5)
.END
```

 *** AC ANALYSIS

FREQ	VM(5)	VP(5)
1.592E+03	9.121E+00	-5.787E+01

13.27 Find V_o in the circuit of Fig. 13-33.

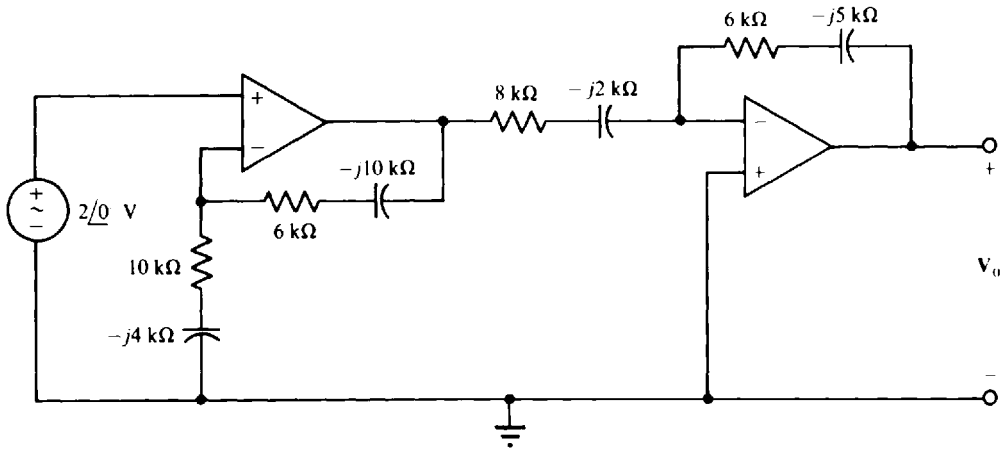

Fig. 13-33

Since the first op-amp circuit has the configuration of a noninverting amplifier, and the second has that of an inverter, the pertinent formulas from Chap. 6 apply, with the R's replaced by Z's. So, with the impedances expressed in kilohms,

$$V_o = \left(1 + \frac{6 - j10}{10 - j4}\right)(-1)\left(\frac{6 - j5}{8 - j2}\right)(2\angle 0) = 3.74\angle 134.8 \text{ V}$$

13.28 Repeat Prob. 13.27 using PSpice.

Figure 13-34 is the PSpice circuit corresponding to the circuit of Fig. 13-33, with the op amps replaced by voltage-controlled voltage sources that are connected across the former op-amp output terminals. In addition, a large resistor R1 has been inserted from node 1 to node 0 to satisfy the PSpice requirement for at least two components connected to each node. The large resistors R4 and R6 have been inserted to provide dc paths from nodes 4 and 7 to node 0, as is required from every node. Without these resistors, the circuit has no such dc paths because of dc blocking by capacitors. The capacitances have been determined using an arbitrary source frequency of 1000 rad/s, which corresponds to $1000/2\pi = 159.155 \text{ Hz}$. As an illustration, for the capacitor which an impedance of $-j4 \text{ k}\Omega$, the magnitude of the reactance is

$$\frac{1}{1000C} = 4000 \quad \text{from which} \quad C = 0.25 \mu\text{F}$$

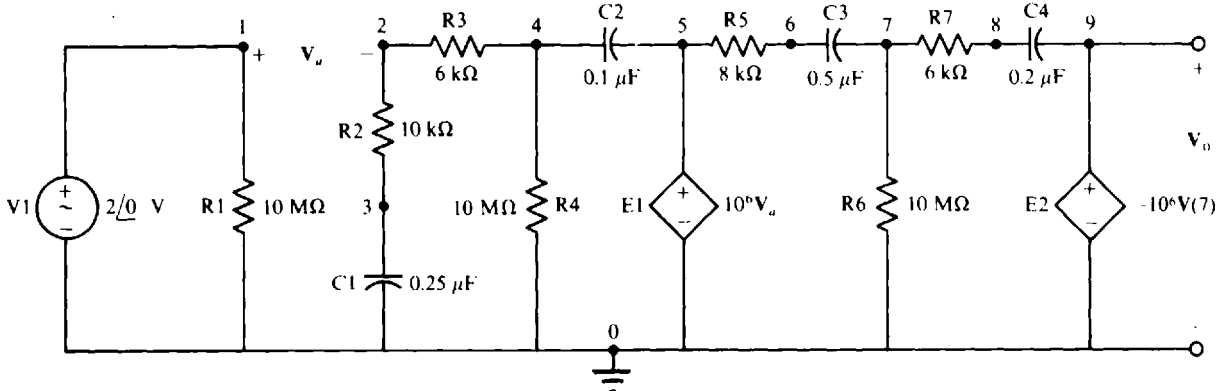

Fig. 13-34

Following is the circuit file for the circuit of Fig. 13-34 and also the results from the output file obtained when the circuit file is run with PSpice. The output of $V(9) = V_o = 3.741/134.8^\circ \text{ V}$ agrees with the answer to Prob. 13.27.

CIRCUIT FILE FOR THE CIRCUIT OF FIG. 13-34

```
V1 1 0 AC 2
R1 1 0 10MEG
R2 2 3 10K
C1 3 0 0.25U
R3 2 4 6K
R4 4 0 10MEG
C2 4 5 0.1U
E1 5 0 1 2 1E6
R5 5 6 8K
C3 6 7 0.5U
R6 7 0 10MEG
R7 7 8 6K
C4 8 9 0.2U
E2 9 0 0 7 1E6
.AC LIN 1 159.155 159.155
.PRINT AC VM(9) VP(9)
.END
```

FREQ	VM(9)	VP(9)
1.592E+02	3.741E+00	1.348E+02

Supplementary Problems

- 13.29** A $30\text{-}\Omega$ resistor and a 0.1-H inductor are in series with a voltage source that produces a voltage of $120 \sin(377t + 10^\circ) \text{ V}$. Find the components for the corresponding phasor-domain current-source transformation.
- Ans.* A current source of $1.76/\underline{-41.5^\circ} \text{ A}$ in parallel with an impedance of $48.2/\underline{51.5^\circ} \Omega$
- 13.30** A $40/\underline{45^\circ} \text{-V}$ voltage source is in series with a $6\text{-}\Omega$ resistor and the parallel combination of a $10\text{-}\Omega$ resistor and an inductor with a reactance of 8Ω . Find the equivalent current-source circuit.
- Ans.* A $3.62/\underline{18.8^\circ} \text{-A}$ current source and a parallel $11/\underline{26.2^\circ} \text{-}\Omega$ impedance
- 13.31** A $2/\underline{30^\circ} \text{-MV}$ voltage source is in series with the parallel arrangement of an inductor that has a reactance of 100Ω and a capacitor that has a reactance of -100Ω . Find the current-source equivalent circuit.
- Ans.* An open circuit
- 13.32** Find the voltage-source circuit equivalent of the parallel arrangement of a $30.4/\underline{-24^\circ} \text{-mA}$ current source, a $60\text{-}\Omega$ resistor, and an inductor with an $80\text{-}\Omega$ reactance.
- Ans.* A $1.46/\underline{12.9^\circ} \text{-V}$ voltage source in series with a $48/\underline{36.9^\circ} \text{-}\Omega$ impedance
- 13.33** A $20.1/\underline{45^\circ} \text{-MA}$ current source is in parallel with the series arrangement of an inductor that has a reactance of 100Ω and a capacitor that has a reactance of -100Ω . Find the equivalent voltage-source circuit.
- Ans.* A short circuit

- 13.34 In the circuit shown in Fig. 13-35, find the currents I_1 and I_2 . Then do a source transformation on the current source and parallel $4/30^\circ\text{-}\Omega$ impedance and find the currents in the impedances. Compare.

Ans. $I_1 = 4.06/14.4^\circ\text{ A}$, $I_2 = 3.25/84.4^\circ\text{ A}$. After the transformation both are $3.25/84.4^\circ\text{ A}$. So, the current does not remain the same in the $4/30^\circ\text{-}\Omega$ impedance involved in the source transformation.

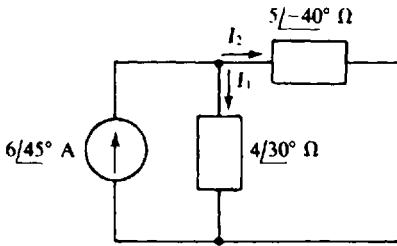

Fig. 13-35

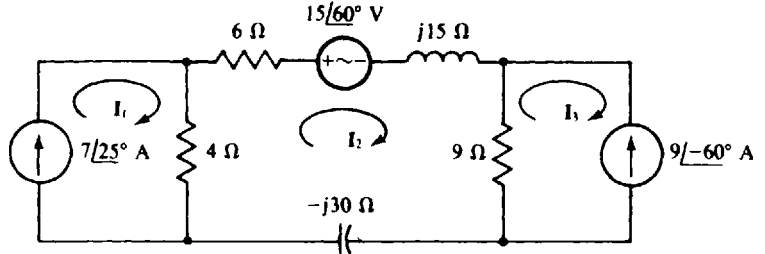

Fig. 13-36

- 13.35 Find the mesh currents in the circuit shown in Fig. 13-36.

Ans. $I_1 = 7/25^\circ\text{ A}$, $I_2 = -3/-33.6^\circ\text{ A}$, $I_3 = -9/-60^\circ\text{ A}$

- 13.36 Find I in the circuit shown in Fig. 13-37.

Ans. $3.86/-34.5^\circ\text{ A}$

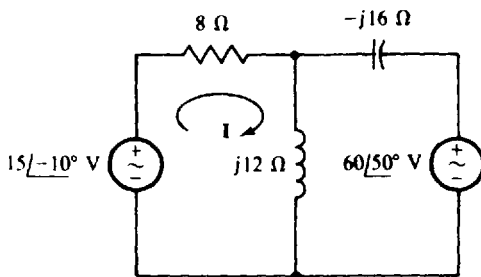

Fig. 13-37

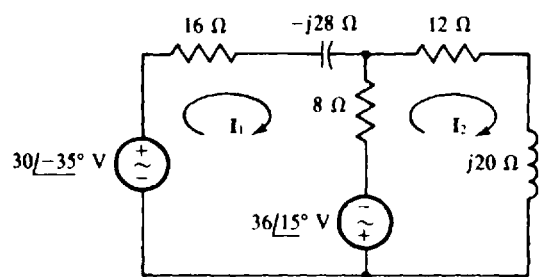

Fig. 13-38

- 13.37 Find the mesh currents in the circuit shown in Fig. 13-38.

Ans. $I_1 = 1.46/46.5^\circ\text{ A}$, $I_2 = -0.945/-43.2^\circ\text{ A}$

- 13.38 Find the mesh currents in the circuit shown in Fig. 13-39.

Ans. $I_1 = 1.26/10.6^\circ\text{ A}$, $I_2 = 4.63/30.9^\circ\text{ A}$, $I_3 = 2.25/-28.9^\circ\text{ A}$

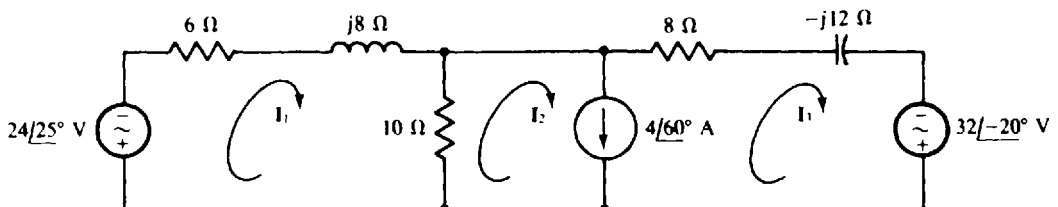

Fig. 13-39

13.39 Use loop analysis to solve for the current that flows down in the 10-Ω resistor in the circuit shown in Fig. 13-39.

Ans. $-3.47/38.1^\circ$ A

13.40 Use mesh analysis to find the current *I* in the circuit shown in Fig. 13-40.

Ans. $40.6/12.9^\circ$ A

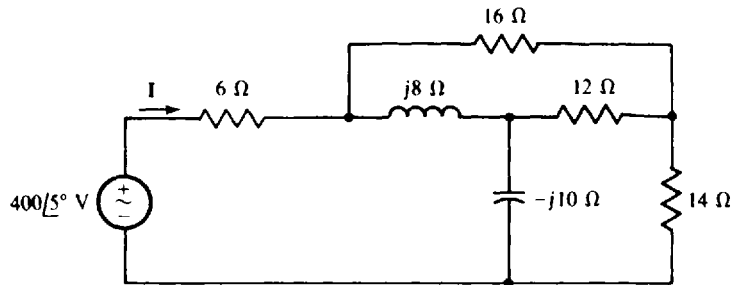

Fig. 13-40

13.41 Use loop analysis to find the current flowing down through the capacitor in the circuit shown in Fig. 13-40.

Ans. $36.1/29.9^\circ$ A

13.42 Find the current *I* in the circuit shown in Fig. 13-41.

Ans. $-13.1/-53.7^\circ$ A

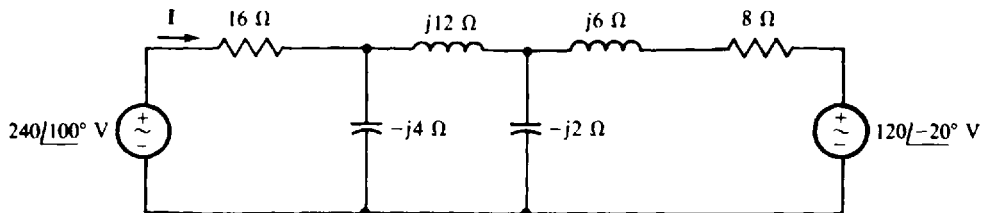

Fig. 13-41

13.43 For the circuit shown in Fig. 13-41, use loop analysis to find the current flowing down through the capacitor that has the reactance of $-j2$ Ω.

Ans. $28.5/-41.5^\circ$ A

13.44 Use loop analysis to find *I* in the circuit shown in Fig. 13-42.

Ans. $2.71/-55.8^\circ$ A

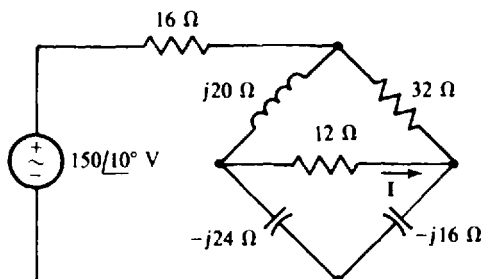

Fig. 13-42

13.45 Rework Prob. 13.44 with all impedances doubled.

Ans. $1.36/\underline{-55.8}$ A

13.46 Find the node voltages in the circuit shown in Fig. 13-43.

Ans. $V_1 = -10.8/\underline{25}$ V, $V_2 = -36/\underline{15}$ V

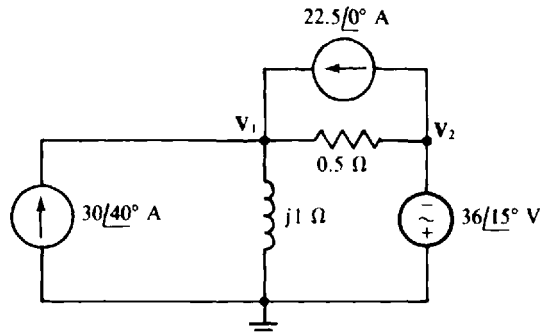

Fig. 13-43

13.47 Find the node voltages in the circuit shown in Fig. 13-44.

Ans. $V_1 = 1.17/\underline{-22.1}$ V, $V_2 = 0.675/\underline{-7.33}$ V

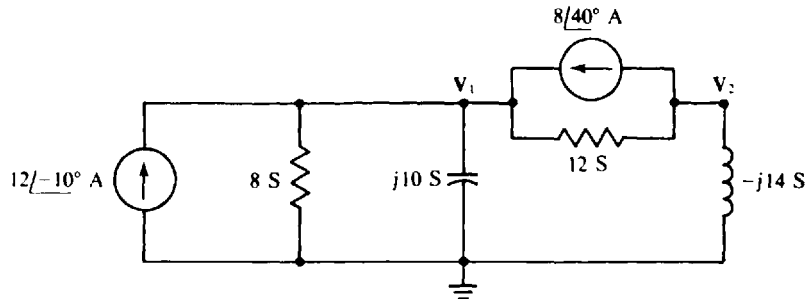

Fig. 13-44

13.48 Solve for the node voltages in the circuit shown in Fig. 13-45.

Ans. $V_1 = -51.9/\underline{-19.1}$ V, $V_2 = 58.7/\underline{73.9}$ V

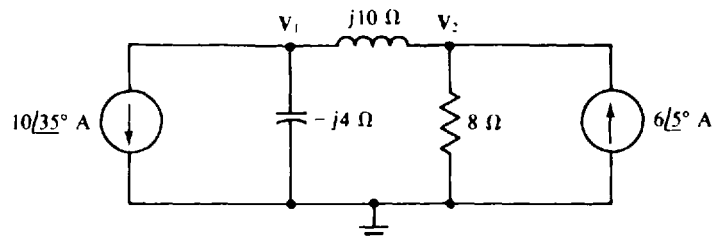

Fig. 13-45

13.49 Find the node voltages in the circuit shown in Fig. 13-46.

Ans. $V_1 = -1.26/\underline{20.6}$ V, $V_2 = -2.25/\underline{-18.9}$ V, $V_3 = -4.63/\underline{40.9}$ V

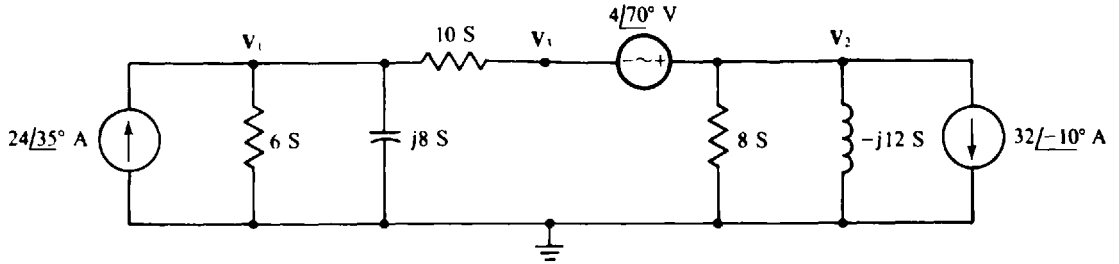

Fig. 13-46

13.50 Solve for the node voltages of the circuit shown in Fig. 13-47.

Ans. $V_1 = 1.75/50.9^\circ$ V, $V_2 = 2.47/-24.6^\circ$ V, $V_3 = 1.53/2.36^\circ$ V

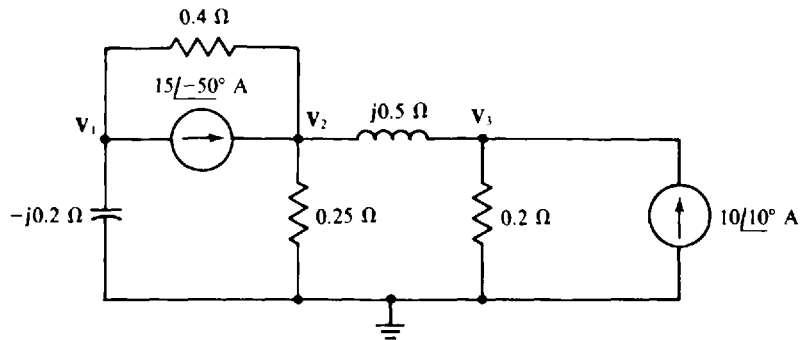

Fig. 13-47

13.51 For the circuit shown in Fig. 13-48, find V as a function of I , and then find V as a numerical value.

Ans. $V = (-6.87 \times 10^3/29.5^\circ)I$, $V = -9.95/68.8^\circ$ V

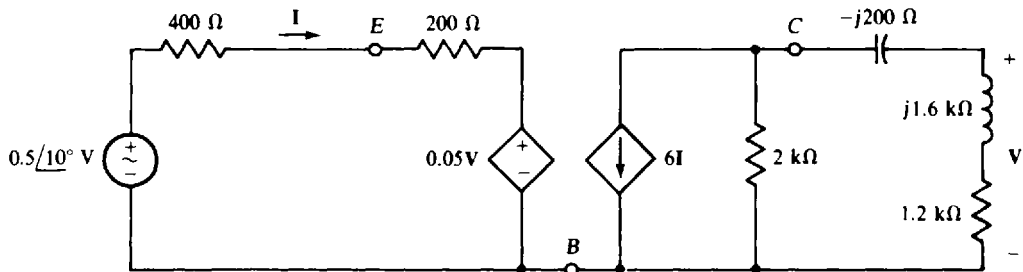

Fig. 13-48

13.52 Solve for I in the circuit shown in Fig. 13-49.

Ans. $-253/34^\circ$ A

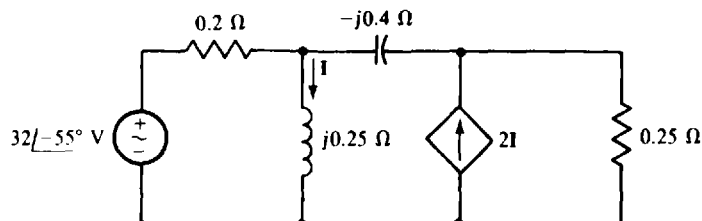

Fig. 13-49

In Probs. 13.53 through 13.58, given the specified PSpice circuit files, determine the output phasor voltages or currents without using PSpice.

13.53

```
CIRCUIT FILE FOR PROB. 13.53
V1 1 0 AC 60 -10
R1 1 2 16
L1 2 0 24
C1 2 3 31.25M
V2 3 0 AC 240 50
.AC LIN 1 0.159155 0.159155
.PRINT AC IM(R1) IP(R1)
.END
```

Ans. $7.72 / -34.5^\circ$ A

13.54

```
CIRCUIT FILE FOR PROB. 13.54
V1 1 0 AC 10 50
R1 1 2 3
L1 2 3 4
R2 3 4 5
C1 4 5 0.166667
V2 0 5 AC 8 -30
R3 3 6 7
L2 6 7 8
V3 7 0 AC 12 20
.AC LIN 1 0.159155 0.159155
.PRINT AC IM(R2) IP(R2)
.END
```

Ans. $1.94 / 35.0^\circ$ A

13.55

```
CIRCUIT FILE FOR PROB. 13.55
I1 0 1 AC 6
R1 1 0 1
C1 1 2 0.25
R2 2 0 2
I2 0 2 AC 6 -90
.AC LIN 1 0.31831 0.31831
.PRINT AC VM(1) VP(1)
.END
```

Ans. $7.44 / -29.7^\circ$ V

13.56

```
CIRCUIT FILE FOR PROB. 13.56
V1 0 1 AC -5 30
R1 1 2 4
R2 2 3 6
E1 3 0 4 0 2
C1 2 4 0.5
F1 4 0 V1 1.5
R3 4 0 10
.AC LIN 1 0.159155 0.159155
.PRINT AC VM(2) VP(2)
.END
```

Ans. $4.64 / 13.0^\circ$ V

13.57

```

CIRCUIT FILE FOR PROB. 13.57
V1 1 0 AC 2 30
R1 1 2 2K
C1 2 3 0.25M
R2 3 0 10MEG
R3 3 4 4K
C2 4 5 0.2M
E1 5 0 0 3 1E6
.AC LIN 1 0.159155 0.159155
.PRINT AC VM(5) VP(5)
.END

```

Ans. $2.86/\underline{-138^\circ}$ V

13.58

```

CIRCUIT FILE FOR PROB. 13.58
V1 1 0 AC 8
R1 1 0 10MEG
R2 2 0 4K
L1 2 3 1
E1 0 3 2 1 1E6
R3 3 4 5K
C1 4 0 0.25U
.AC LIN 1 318.31 318.31
.PRINT AC IM(E1) IP(E1)
.END

```

Ans. $3.34/\underline{21.8^\circ}$ mA

AC Equivalent Circuits, Network Theorems, and Bridge Circuits

INTRODUCTION

With two minor modifications, the dc network theorems discussed in Chap. 5 apply as well to ac phasor-domain circuits: The maximum power transfer theorem has to be modified slightly for circuits containing inductors or capacitors, and the same is true of the superposition theorem if the time-domain circuits have sources of different frequencies. Otherwise, though, the applications of the theorems for ac phasor-domain circuits are essentially the same as for dc circuits.

THÉVENIN'S AND NORTON'S THEOREMS

In the application of Thévenin's or Norton's theorems to an ac phasor-domain circuit, the circuit is divided into two parts, *A* and *B*, with two joining wires, as shown in Fig. 14-1*a*. Then, for Thévenin's theorem applied to part *A*, the wires are separated at terminals *a* and *b*, and the open-circuit voltage V_{Th} , the *Thévenin voltage*, is found referenced positive at terminal *a*, as shown in Fig. 14-1*b*. The next step, as shown in Fig. 14-1*c*, is to find *Thévenin's impedance* Z_{Th} of part *A* at terminals *a* and *b*. For Thévenin's theorem to apply, part *A* must be linear and bilateral, just as for a dc circuit.

There are three ways to find Z_{Th} . For one way, part *A* must have no dependent sources. Also, preferably, the impedances are arranged in a series-parallel configuration. In this approach, the independent sources in part *A* are deactivated, and then Z_{Th} is found by combining impedances and admittances—that is, by circuit reduction.

If the impedances of part *A* are not arranged series-parallel, it may not be convenient to use circuit reduction. Or, it may be impossible, especially if part *A* has dependent sources. In this case, Z_{Th} can

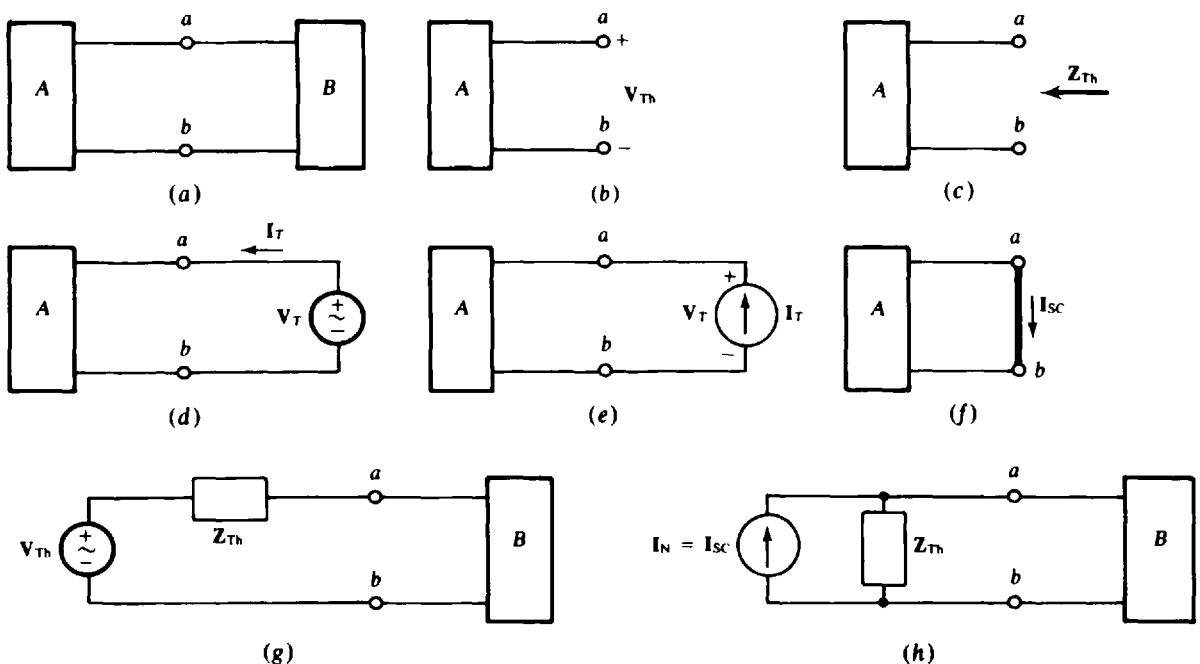

Fig. 14-1

be found in a second way by applying a voltage source as shown in Fig. 14-1d or a current source as shown in Fig. 14-1e, and finding $Z_{Th} = V_T / I_T$. Often, the most convenient source voltage is $V_T = 1/0 \angle 0^\circ \text{ V}$ and the most convenient source current is $I_T = 1/0 \text{ A}$.

The third way to find Z_{Th} is to apply a short circuit across terminals a and b , as shown in Fig. 14-1f, then find the short-circuit current I_{sc} , and use it in $Z_{Th} = V_{Th} / I_{sc}$. Of course, V_{Th} must also be known. For this approach, part A must have independent sources, and they must not be deactivated.

In the circuit shown in Fig. 14-1g, the Thévenin equivalent produces the same voltages and currents in part B that the original part A does. But only the part B voltages and currents remain the same; those in part A almost always change, except at the a and b terminals.

For the Norton equivalent circuit shown in Fig. 14-1h, the Thévenin impedance is in parallel with a current source that provides a current *up* that is equal to the short-circuit current *down* in the circuit shown in Fig. 14-1f. The Norton equivalent circuit also produces the same part B voltages and currents that the original part A does.

Because of the relation $V_{Th} = I_{sc} Z_{Th}$, any two of the three quantities V_{Th} , I_{sc} , and Z_{Th} can be found from part A and then this equation used to find the third quantity if it is needed for the application of either Thévenin's or Norton's theorem. Obviously, PSpice can be used to obtain the needed two quantities, one at a time, as should be apparent. However, the .TF feature explained in Prob. 7.5 cannot be used for this since its use is limited to dc analyses.

MAXIMUM POWER TRANSFER THEOREM

The load that absorbs maximum average power from a circuit can be found from the Thévenin equivalent of this circuit at the load terminals. The load should have a reactance that cancels the reactance of this Thévenin impedance because reactance does not absorb any average power but *does* limit the current. Obviously, for maximum power transfer, there should be no reactance limiting the current flow to the resistance part of the load. This, in turn, means that the load and Thévenin reactances must be equal in magnitude but opposite in sign.

With the reactance cancellation, the overall circuit becomes essentially purely resistive. As a result, the rule for maximum power transfer for the resistances is the same as that for a dc circuit: The load resistance must be equal to the resistance part of the Thévenin impedance. Having the same resistance but a reactance that differs only in sign, *the load impedance for maximum power transfer is the conjugate of the Thévenin impedance of the circuit connected to the load: $Z_L = Z_{Th}^*$* . Also, because the overall circuit is purely resistive, the maximum power absorbed by the load is the same as for a dc circuit: $V_{Th}^2 / 4R_{Th}$, in which V_{Th} is the rms value of the Thévenin voltage V_{Th} and R_{Th} is the resistance part of Z_{Th} .

SUPERPOSITION THEOREM

If, in an ac time-domain circuit, the independent sources operate at the *same* frequency, the superposition theorem for the corresponding phasor-domain circuit is the same as for a dc circuit. That is, the desired voltage or current phasor contribution is found from each individual source or combination of sources, and then the various contributions are algebraically added to obtain the desired voltage or current phasor. Independent sources not involved in a particular solution are deactivated, but dependent sources are left in the circuit.

For a circuit in which all sources have the same frequency, an analysis with the superposition theorem is usually more work than a standard mesh, loop, or nodal analysis with all sources present. But the superposition theorem is essential if a time-domain circuit has inductors or capacitors and has sources operating at *different* frequencies. Since the reactances depend on the radian frequency, the same phasor-domain circuit cannot be used for all sources if they do not have the same frequency. There must be a different phasor-domain circuit for each different radian frequency, with the differences being in the reactances and in the deactivation of the various independent sources. Preferably, all independent sources having the same radian frequency are considered at a time, while the other independent sources are

deactivated. This radian frequency is used to find the inductive and capacitive reactances for the corresponding phasor-domain circuit, and this circuit is analyzed to find the desired phasor. Then, the phasor is transformed to a sinusoid. This process is repeated for each different radian frequency of the sources. Finally, the individual sinusoidal responses are added to obtain the total response. Note that the adding is of the sinusoids and not of the phasors. This is because phasors of different frequencies cannot be validly added.

AC Y-Δ and Δ-Y TRANSFORMATIONS

Chapter 5 presents the Y-Δ and Δ-Y transformation formulas for resistances. The only difference for impedances is in the use of Z's instead of R's. Specifically, for the Δ-Y arrangement shown in Fig. 14-2, the Y-to-Δ transformation formulas are

$$Z_1 = \frac{Z_A Z_B + Z_A Z_C + Z_B Z_C}{Z_B} \quad Z_2 = \frac{Z_A Z_B + Z_A Z_C + Z_B Z_C}{Z_C} \quad Z_3 = \frac{Z_A Z_B + Z_A Z_C + Z_B Z_C}{Z_A}$$

and the Δ-to-Y transformation formulas are

$$Z_A = \frac{Z_1 Z_2}{Z_1 + Z_2 + Z_3} \quad Z_B = \frac{Z_2 Z_3}{Z_1 + Z_2 + Z_3} \quad Z_C = \frac{Z_1 Z_3}{Z_1 + Z_2 + Z_3}$$

The Y-to-Δ transformation formulas all have the same numerator, which is the sum of the different products of the pairs of the Y impedances. Each denominator is the Y impedance shown in Fig. 14-2 that is opposite the impedance being found. The Δ-to-Y transformation formulas, on the other hand, have the same denominator, which is the sum of the Δ impedances. Each numerator is the product of the two Δ impedances shown in Fig. 14-2 that are adjacent to the Y impedance being found.

If all three Y impedances are the same Z_Y , the Y-to-Δ transformation formulas are the same: $Z_\Delta = 3Z_Y$. And if all three Δ impedances are the same Z_Δ , the Δ-to-Y transformation formulas are the same: $Z_Y = Z_\Delta/3$.

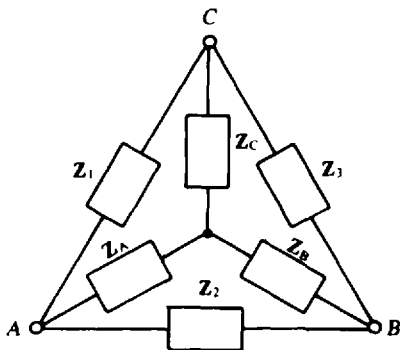

Fig. 14-2

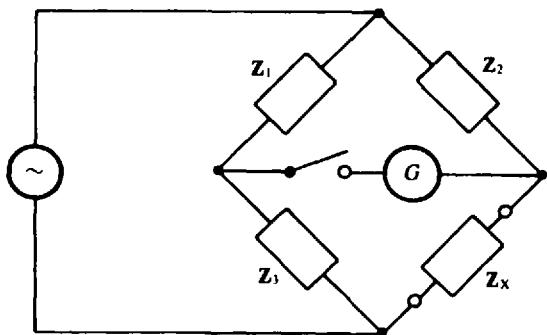

Fig. 14-3

AC BRIDGE CIRCUITS

An ac bridge circuit, as shown in Fig. 14-3, can be used to measure inductance or capacitance in the same way that a Wheatstone bridge can be used to measure resistance, as explained in Chap. 5. The bridge components, except for the unknown impedance Z_X , are typically just resistors and a capacitance standard—a capacitor the capacitance of which is known to great precision. For a measurement, two of the resistors are varied until the galvanometer in the center arm reads zero when the switch is closed.

Then the bridge is balanced, and the unknown impedance Z_X can be found from the bridge balance equation $Z_X = Z_2 Z_3 / Z_1$, which is the same as that for a Wheatstone bridge except for having Z 's instead of R 's.

Solved Problems

In those Thévenin and Norton equivalent circuit problems in which the equivalent circuits are not shown, the equivalent circuits are as shown in Fig. 14-1*g* and *h* with V_{Th} referenced positive at terminal *a* and $I_N = I_{SC}$ referenced toward the same terminal. The Thévenin impedance is, of course, in series with the Thévenin voltage source in the Thévenin equivalent circuit, and is in parallel with the Norton current source in the Norton equivalent circuit.

- 14.1 Find Z_{Th} , V_{Th} , and I_N for the Thévenin and Norton equivalents of the circuit external to the load impedance Z_L in the circuit shown in Fig. 14-4.

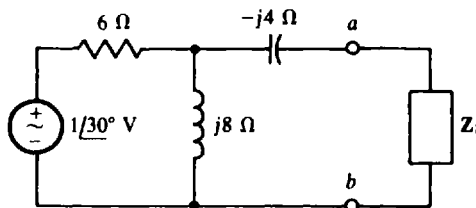

Fig. 14-4

The Thévenin impedance Z_{Th} is the impedance at terminals *a* and *b* with the load impedance removed and the voltage source replaced by a short circuit. From combining impedances,

$$Z_{Th} = -j4 + \frac{6(j8)}{6 + j8} = -j4 + 4.8/36.87^\circ = 4/-16.26^\circ \Omega$$

Although either V_{Th} or I_N can be found next, V_{Th} should be found because the $-j4\text{-}\Omega$ series branch makes I_N more difficult to find. With an open circuit at terminals *a* and *b*, this branch has zero current and so zero voltage. Consequently, V_{Th} is equal to the voltage drop across the $j8\text{-}\Omega$ impedance. By voltage division,

$$V_{Th} = \frac{j8}{6 + j8} \times 1/30^\circ = \frac{8/120^\circ}{10/53.13^\circ} = 0.8/66.87^\circ \text{ V}$$

Finally,

$$I_N = \frac{V_{Th}}{Z_{Th}} = \frac{0.8/66.87^\circ}{4/-16.26^\circ} = 0.2/83.1^\circ \text{ A}$$

- 14.2 If in the circuit shown in Fig. 14-4 the load is a resistor with resistance R , what value of R causes a 0.1-A rms current to flow through the load?

As is evident from Fig. 14-1*g*, the load current is equal to the Thévenin voltage divided by the sum of the Thévenin and load impedances:

$$I_L = \frac{V_{Th}}{Z_{Th} + Z_L} \quad \text{from which} \quad Z_{Th} + Z_L = \frac{V_{Th}}{I_L}$$

Since only the rms load current is specified, angles are not known, which means that magnitudes must be used. Substituting $V_{Th} = 0.8 \text{ V}$ from the solution to Prob. 14.1,

$$|Z_{Th} + Z_L| = \frac{V_{Th}}{I_L} = \frac{0.8}{0.1} = 8 \Omega$$

Also from this solution, $Z_{Th} = 4 \angle -16.26^\circ \Omega$. So,

$$|4 \angle -16.26^\circ + R| = 8 \quad \text{or} \quad |3.84 - j1.12 + R| = 8$$

Because the magnitude of a complex number is equal to the square root of the sum of the squares of the real and imaginary parts,

$$\sqrt{(3.84 + R)^2 + (-1.12)^2} = 8$$

Squaring and simplifying,

$$R^2 + 7.68R + 16 = 64 \quad \text{or} \quad R^2 + 7.68R - 48 = 0$$

Applying the quadratic formula,

$$R = \frac{-7.68 \pm \sqrt{7.68^2 - 4(-48)}}{2} = \frac{-7.68 \pm 15.84}{2}$$

The positive sign must be used to obtain a physically significant positive resistance. So,

$$R = \frac{-7.68 + 15.84}{2} = 4.08 \Omega$$

Note in the solution that the Thévenin and load impedances must be added before and not after the magnitudes are taken. This is because $|Z_{Th}| + |Z_L| \neq |Z_L + Z_{Th}|$.

- 14.3** Find Z_{Th} , V_{Th} , and I_N for the Thévenin and Norton equivalents of the circuit shown in Fig. 14-5.

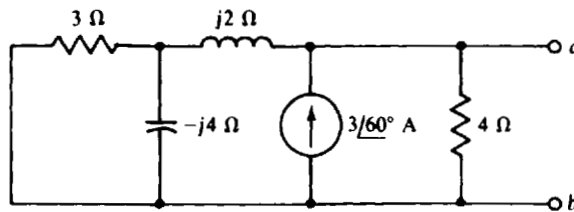

Fig. 14-5

The Thévenin impedance Z_{Th} is the impedance at terminals a and b with the current source replaced by an open circuit. By circuit reduction,

$$Z_{Th} = 4 \parallel [j2 + 3 \parallel (-j4)] = \frac{4[j2 + 3(-j4)](3 - j4)}{4 + j2 + 3(-j4)(3 - j4)}$$

Multiplying the numerator and denominator by $3 - j4$ gives

$$Z_{Th} = \frac{4[j2(3 - j4) - j12]}{(4 + j2)(3 - j4) - j12} = \frac{40 \angle -36.87^\circ}{29.7 \angle -47.73^\circ} = 1.35 \angle 10.9^\circ \Omega$$

The short-circuit current is easy to find because, if a short circuit is placed across terminals a and b , all the source current flows through this short circuit: $I_{SC} = I_N = 3/60 \text{ A}$. None of the source current can flow through the impedances because the short circuit places a zero voltage across them. Finally,

$$V_{Th} = I_N Z_{Th} = (3/60)(1.35 \angle 10.9^\circ) = 4.04 \angle 70.9^\circ \text{ V}$$

14.4 Find Z_{Th} , V_{Th} , and I_N for the Thévenin and Norton equivalents of the circuit shown in Fig. 14-6.

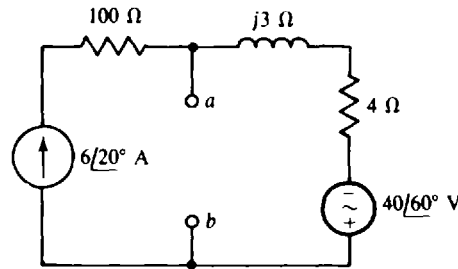

Fig. 14-6

The Thévenin impedance Z_{Th} is the impedance at terminals a and b , with the current source replaced by an open circuit and the voltage source replaced by a short circuit. The 100- Ω resistor is then in series with the open circuit that replaced the current source. Consequently, this resistor has no effect on Z_{Th} . The $j3$ - and 4- Ω impedances are placed across terminals a and b by the short circuit that replaces the voltage source. As a result, $Z_{Th} = 4 + j3 = 5\angle 36.9^\circ \Omega$.

The short-circuit current $I_{Sc} = I_N$ will be found and used to obtain V_{Th} . If a short circuit is placed across terminals a and b , the current to the right through the $j3$ - Ω impedance is

$$\frac{40/60}{4 + j3} = \frac{40/60}{5\angle 36.9} = 8/23.1 \text{ A}$$

because the short circuit places all the 40/60 V of the voltage source across the 4- and $j3$ - Ω impedances. Of course, the current to the right through the 100- Ω resistor is the 6/20 -A source current. By KCL applied at terminal a , the short-circuit current is the difference between these currents:

$$I_{Sc} = I_N = 6/20 - 8/23.1 = 2.04\angle -147.6 = -2.04\angle 32.4 \text{ A}$$

Finally,

$$V_{Th} = I_N Z_{Th} = (-2.04\angle 32.4)(5\angle 36.9) = -10.2\angle 69.3 \text{ V}$$

The negative signs for I_N and V_{Th} can, of course, be eliminated by reversing the references—that is, by having the Thévenin voltage source positive toward terminal b and the Norton current directed toward terminal b .

As a check, V_{Th} can be found from the open-circuit voltage across terminals a and b . Because of this open circuit, all the 6/20 -A source current must flow through the 4- and $j3$ - Ω impedances. Consequently, from the right-hand half of the circuit, the voltage drop from terminal a to b is

$$V_{Th} = (6/20)(4 + j3) - 40/60 = 30\angle 56.9 - 40/60 = 10.2\angle -110.7 = -10.2\angle 69.3 \text{ V}$$

which checks.

14.5 Find Z_{Th} and V_{Th} for the Thévenin equivalent of the circuit shown in Fig. 14-7.

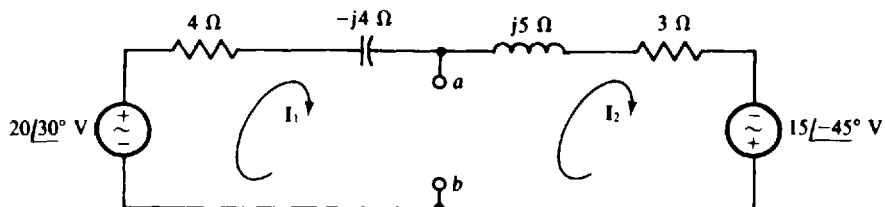

Fig. 14-7

The Thévenin impedance Z_{Th} can be found easily by replacing the voltage sources with short circuits and finding the impedances at terminals a and b . Since the short circuit places the right- and left-hand halves of the circuit in parallel,

$$Z_{Th} = \frac{(4 - j4)(3 + j5)}{4 - j4 + 3 + j5} = \frac{32 + j8}{7 + j1} = \frac{32.98/14.04}{7.07/8.13} = 4.66/5.91 \ \Omega$$

A brief inspection of the circuit shows that the short-circuit current is easier to find than the open-circuit voltage. This current from terminal a to b is

$$I_{sc} = I_1 - I_2 = \frac{20/30}{4 - j4} - \frac{15/-45}{3 + j5} = 3.54/75 - 2.57/-104 = 6.11/75.4 \text{ A}$$

Finally,
$$V_{Th} = I_{sc} Z_{Th} = (6.11/75.4)(4.66/5.91) = 28.5/81.3 \text{ V}$$

14.6 Find Z_{Th} and V_{Th} for the Thévenin equivalent of the circuit shown in Fig. 14-8.

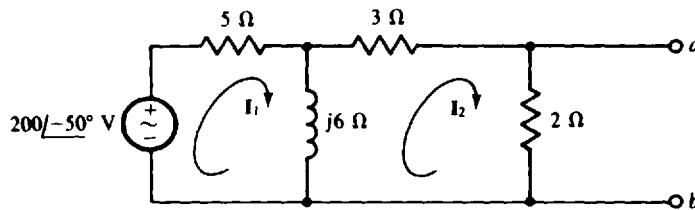

Fig. 14-8

If the voltage source is replaced by a short circuit, the impedance Z_{Th} at terminals a and b is, by circuit reduction,

$$Z_{Th} = 2(3 + j6 \parallel 5) = \frac{2[3 + 5(j6)(5 + j6)]}{2 + 3 + 5(j6)(5 + j6)} = 1.55/5.27 \ \Omega$$

The Thévenin voltage can be found from I_2 , and I_2 can be found from mesh analysis. The mesh equations are, from the self-impedance and mutual-impedance approach,

$$\begin{aligned} (5 + j6)I_1 - j6I_2 &= 200\angle-50 \\ -j6I_1 + (5 + j6)I_2 &= 0 \end{aligned}$$

If Cramer's rule is used to obtain I_2 , then

$$I_2 = \frac{\begin{vmatrix} 5 + j6 & 200\angle-50 \\ -j6 & 0 \end{vmatrix}}{\begin{vmatrix} 5 + j6 & -j6 \\ -j6 & 5 + j6 \end{vmatrix}} = \frac{-(-j6)(200\angle-50)}{(5 + j6)^2 - (-j6)^2} = \frac{1200/40}{65/67.4} = 18.46/-27.4 \text{ A}$$

And
$$V_{Th} = 2I_2 = 2(18.46/-27.4) = 36.9/-27.4 \text{ V}$$

14.7 Find Z_{Th} and I_N for the Norton equivalent of the circuit shown in Fig. 14-9.

When the current source is replaced by an open circuit and the voltage source is replaced by a short circuit, the impedance at terminals a and b is

$$Z_{Th} = 4 + \frac{5(-j8)}{5 - j8} = \frac{20 - j72}{5 - j8} = 7.92/-16.48^\circ \ \Omega$$

Because of the series arm connected to terminal a and the voltage source in it, the Norton current is best found from the Thévenin voltage and impedance. The Thévenin voltage is equal to the voltage drop

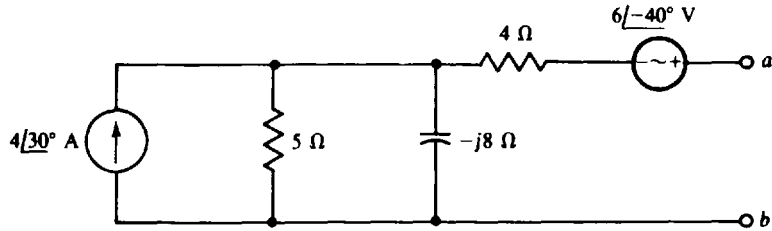

Fig. 14-9

across the parallel components plus the voltage of the voltage source:

$$V_{Th} = \frac{5(-j8)}{5 - j8} \times 4\angle 30^\circ + 6\angle -40^\circ = 22\angle -11.67^\circ \text{ V}$$

And

$$I_N = \frac{V_{Th}}{Z_{Th}} = \frac{22\angle -11.67^\circ}{7.92\angle -16.48^\circ} = 2.78\angle 4.81^\circ \text{ A}$$

14.8 Find Z_{Th} and V_{Th} for the Thévenin equivalent of the circuit shown in Fig. 14-10.

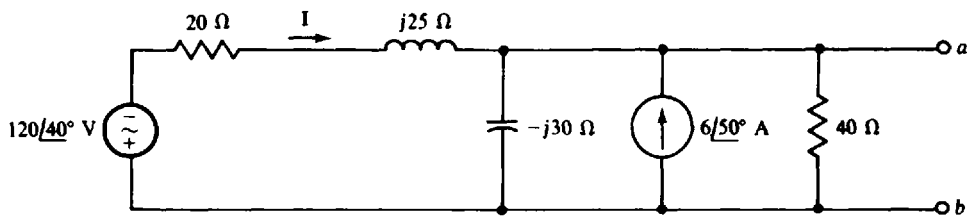

Fig. 14-10

When the voltage source is replaced by a short circuit and the current source by an open circuit, the admittance at terminals a and b is

$$\frac{1}{40} + \frac{1}{-j30} + \frac{1}{20 + j25} = 0.025 + j0.0333 + 0.0195 - j0.0244 = 0.0454\angle 11.36^\circ \text{ S}$$

The inverse of this is Z_{Th} :

$$Z_{Th} = \frac{1}{0.0454\angle 11.36^\circ} = 22\angle -11.36^\circ \Omega$$

Because of the generally parallel configuration of the circuit, it may be better not to find V_{Th} directly, but rather to obtain I_N first and then find V_{Th} from $V_{Th} = I_N Z_{Th}$. If a short circuit is placed across terminals a and b , the short-circuit current is $I + 6\angle 50^\circ$ since the short circuit prevents any current flow through the two parallel impedances. The current I can be found from the source voltage divided by the sum of the series impedances since the short circuit places this voltage across these impedances:

$$I = -\frac{120\angle 40^\circ}{20 + j25} = -3.75\angle -11.3^\circ \text{ A}$$

And so

$$I_N = I + 6\angle 50^\circ = -3.75\angle -11.3^\circ + 6\angle 50^\circ = 5.34\angle 88.05^\circ \text{ A}$$

Finally,

$$V_{Th} = I_N Z_{Th} = (5.34\angle 88.05^\circ)(22\angle -11.36^\circ) = 118\angle 76.7^\circ \text{ V}$$

14.9 Using Thévenin's or Norton's theorem, find I in the bridge circuit shown in Fig. 14-11 if $I_5 = 0 \text{ A}$.

Since the current source produces 0 A, it is equivalent to an open circuit and can be removed from the circuit. Also, the 2-Ω and j3-Ω impedances need to be removed in finding an equivalent circuit because these

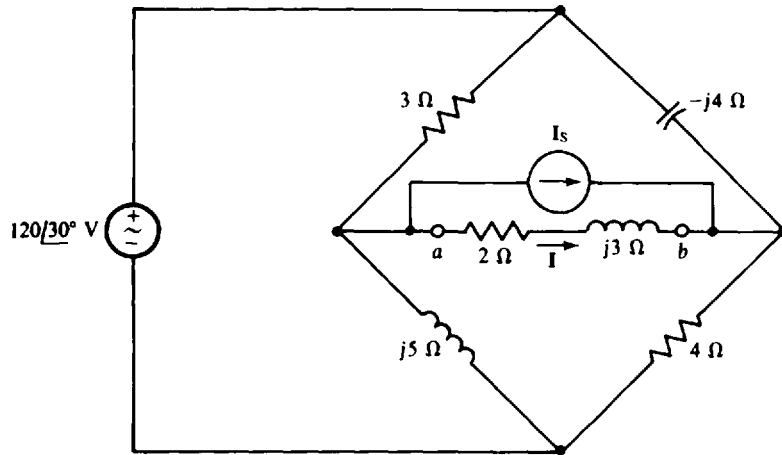

Fig. 14-11

are the load impedances. With this done, Z_{Th} can be found after replacing the voltage source with a short circuit. This short circuit places the $3\text{-}\Omega$ and $j5\text{-}\Omega$ impedances in parallel and also the $-j4\text{-}\Omega$ and $4\text{-}\Omega$ impedances in parallel. Since these two parallel arrangements are in series between terminals a and b ,

$$Z_{Th} = 3 \parallel j5 + 4 \parallel (-j4) = \frac{3(j5)}{3 + j5} + \frac{4(-j4)}{4 - j4} = 2.572 \angle 30.96^\circ + 2.828 \angle -45^\circ = 4.26 \angle -9.14^\circ \Omega$$

The open-circuit voltage is easier to find than the short-circuit current. By KVL applied at the bottom half of the bridge, V_{Th} is equal to the difference in voltage drops across the $j5\text{-}\Omega$ and $4\text{-}\Omega$ impedances, which drops can be found by voltage division. Thus,

$$V_{Th} = \frac{j5}{3 + j5} \times 120 \angle 30^\circ - \frac{4}{4 - j4} \times 120 \angle 30^\circ = 29.1 \angle 16^\circ \text{ V}$$

As should be evident from the Thévenin discussion and also from Fig. 14-1*g*, I is equal to the Thévenin voltage divided by the sum of the Thévenin and load impedances:

$$I = \frac{29.1 \angle 16^\circ}{4.26 \angle -9.14^\circ + 2 + j3} = 4.39 \angle -4.5^\circ \text{ A}$$

14.10 Find I for the circuit shown in Fig. 14-11 if $I_s = 10 \angle -50^\circ \text{ A}$.

The current source does not affect Z_{Th} , which has the same value as found in the solution to Prob. 14.9: $Z_{Th} = 4.26 \angle -9.14^\circ \Omega$. The current source does, however, contribute to the Thévenin voltage. By superposition, it contributes a voltage equal to the source current times the impedance at terminals a and b with the load replaced by an open circuit. Since this impedance is Z_{Th} , the voltage contribution of the current source is $(10 \angle -50^\circ)(4.26 \angle -9.14^\circ) = 42.6 \angle -59.1^\circ \text{ V}$, which is a voltage drop from terminal b to a because the direction of the source current is into terminal b . Consequently, the Thévenin voltage is, by superposition, the Thévenin voltage obtained in the solution to Prob. 14.9 minus this voltage:

$$V_{Th} = 29.1 \angle 16^\circ - 42.6 \angle -59.1^\circ = 45 \angle 82.1^\circ \text{ V}$$

and

$$I = \frac{V_{Th}}{Z_{Th} + Z_L} = \frac{45 \angle 82.1^\circ}{4.26 \angle -9.14^\circ + (2 + j3)} = \frac{45 \angle 82.1^\circ}{6.63 \angle 20.5^\circ} = 6.79 \angle 61.6^\circ \text{ A}$$

14.11 Find the output impedance of the circuit to the left of terminals a and b for the circuit shown in Fig. 14-12.

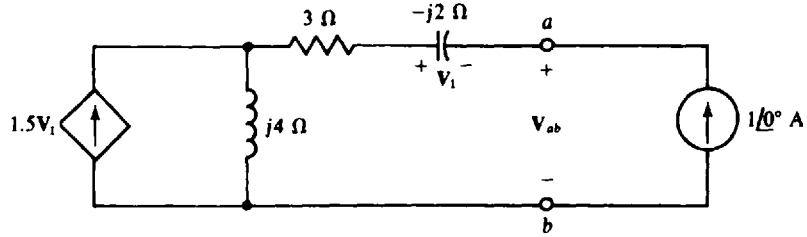

Fig. 14-12

The output impedance is the same as the Thévenin impedance. The only way of finding Z_{Th} is by applying a source and finding the ratio of the voltage and current at the source terminals. This impedance cannot be found from $Z_{Th} = V_{Th} / I_N$ because V_{Th} and I_N are both zero since there are no independent sources to the left of terminals a and b . And, of course, circuit reduction cannot be used because of the presence of the dependent source. The most convenient source to apply is a $1/0^\circ$ -A current source with a current direction into terminal a , as shown in Fig. 14-12. Then, $Z_{Th} = V_{ab} / 1/0^\circ = V_{ab}$.

The first step in calculating Z_{Th} is to find the control voltage V_1 . It is $V_1 = -(-j2)(1/0^\circ) = j2$ V, with the initial negative sign occurring because the capacitor voltage and current references are not associated (The $1/0^\circ$ -A current is directed into the negative terminal of V_1). The next step is to find the current flowing down through the $j4$ - Ω impedance. This is the $1/0^\circ$ -A current from the independent current source plus the $1.5V_1 = 1.5(j2) = j3$ -A current from the dependent current source, a total of $1 + j3$ A. With this current known, the voltage V_{ab} can be found from the sum of the voltage drops across the three impedances:

$$V_{ab} = (1/0^\circ)(3 - j2) + (1 + j3)(j4) = 3 - j2 + j4 - 12 = -9 + j2 \text{ V}$$

which, as mentioned, means that $Z_{Th} = -9 + j2 \Omega$. The negative resistance (-9Ω) is the result of the action of the dependent source. In polar form this impedance is

$$Z_{Th} = -9 + j2 = 9.22/167.5^\circ = -9.22/-12.5^\circ \Omega$$

14.12 Find Z_{Th} and I_N for the Norton equivalent of the circuit shown in Fig. 14-13.

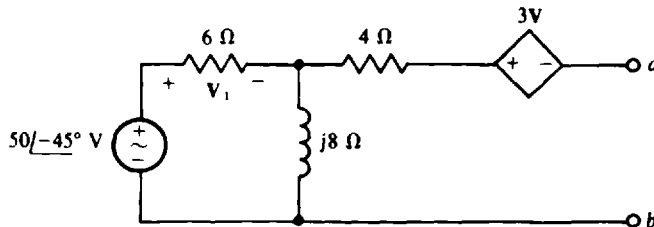

Fig. 14-13

Because of the series arm with dependent source connected to terminal a , V_{Th} is easier to find than I_N . This voltage is equal to the sum of the voltage drops across the $j8$ - Ω impedance and the $3V_1$ dependent voltage source. (Of course, the 4 - Ω resistor has a 0 -V drop.) It is usually best to first solve for the controlling quantity, which here is the voltage V_1 across the 6 - Ω resistor. By voltage division,

$$V_1 = \frac{6}{6 + j8} \times 50/_{-45^\circ} = 30/_{-98.1^\circ} \text{ V}$$

Since there is a 0 -V drop across the 4 - Ω resistor, KVL applied around the outside loop gives

$$V_{Th} = 50/_{-45^\circ} - V_1 - 3V_1 = 50/_{-45^\circ} - 4(30/_{-98.1^\circ}) = 98.49/_{57.91^\circ} \text{ V}$$

The Thévenin impedance can be found by applying a current source of $1/0^\circ$ A at terminals a and b , as shown in the circuit in Fig. 14-14, and finding the voltage V_{ab} . Then, $Z_{Th} = V_{ab} / 1/0^\circ = V_{ab}$. The control voltage V_1 must be found first, as to be expected. It has a different value than in the V_{Th} calculation because

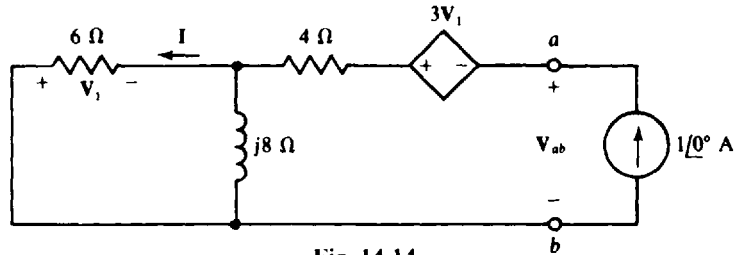

Fig. 14-14

the circuit is different. The voltage V_1 can be found from the current I flowing through the $6\text{-}\Omega$ resistor across which V_1 is taken. Since the $6\text{-}\Omega$ and $j8\text{-}\Omega$ impedances are in parallel, and since $1\angle 0^\circ$ A from the current source flows into this parallel arrangement, I is, by current division,

$$I = \frac{j8}{6 + j8} \times 1\angle 0^\circ = 0.8\angle 36.9^\circ \text{ A}$$

And, by Ohm's law,

$$V_1 = -6I = -6(0.8\angle 36.9^\circ) = -4.8\angle 36.9^\circ \text{ V}$$

The negative sign is needed because the V_1 and I references are not associated.

With V_1 known, V_{ab} can be found by summing the voltage drops from terminal a to terminal b :

$$V_{ab} = -3(-4.8\angle 36.9^\circ) + (1\angle 0^\circ)(4) - (-4.8\angle 36.9^\circ) = 22.53\angle 30.75^\circ \text{ V}$$

from which $Z_{Th} = 22.53\angle 30.75^\circ \Omega$.

$$\text{Finally, } I_N = \frac{V_{Th}}{Z_{Th}} = \frac{98.49\angle 57.91^\circ}{22.53\angle 30.75^\circ} = 4.37\angle 27.2^\circ \text{ A}$$

14.13 Find Z_{Th} and I_N for the Norton equivalent of the transistor circuit shown in Fig. 14.15.

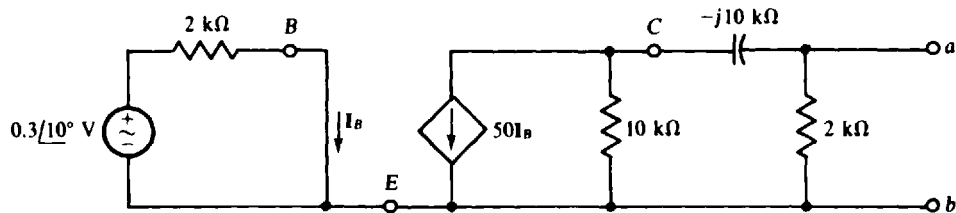

Fig. 14-15

The Thévenin impedance Z_{Th} can be found directly by replacing the independent voltage source by a short circuit. Since with this replacement there is no source of voltage in the base circuit, $I_B = 0$ A and so the $50I_B$ of the dependent current source is also 0 A. And this means that this dependent source is equivalent to an open circuit. Notice that the dependent source was not deactivated, as an independent source would be. Instead, it is equivalent to an open circuit because its control current is 0 A. With this current source replaced by an open circuit, Z_{Th} can be found by combining impedances:

$$Z_{Th} = \frac{2000(10\,000 - j10\,000)}{2000 + 10\,000 - j10\,000} = 1.81\angle -5.19^\circ \text{ k}\Omega$$

The current I_N can be found from the current flowing through a short circuit placed across terminals a and b . Because this short circuit places the $10\text{-k}\Omega$ and $-j10\text{-k}\Omega$ impedances in parallel, and since I_N is the current through the $-j10\text{-k}\Omega$ impedance, then by current division I_N is

$$I_N = -\frac{10\,000}{10\,000 - j10\,000} \times 50I_B = \frac{-50I_B}{\sqrt{2}\angle -45^\circ}$$

The initial negative sign is necessary because both $50I_B$ and I_N have directions into terminal b . The $2\text{-k}\Omega$ resistance across terminals a and b does not appear because it is in parallel with the short circuit.

From the base circuit,

$$I_B = \frac{0.3/10}{2000} \text{ A} = 0.15/10 \text{ mA}$$

Finally,

$$I_N = -\frac{50(0.15/10)}{\sqrt{2/-45}} = -5.3/55 \text{ mA}$$

14.14. Use PSpice to obtain the Thévenin equivalent of the circuit of Fig. 14-16.

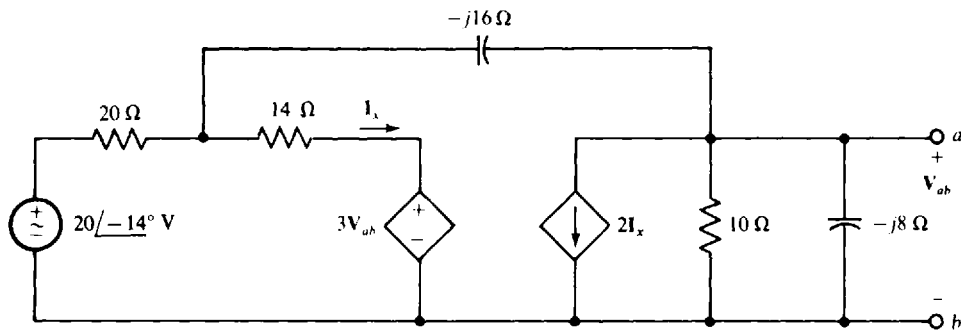

Fig. 14-16

In general, using PSpice to obtain a Thévenin equivalent involves running PSpice twice to obtain two of the three quantities V_{Th} , R_{Th} , and I_N . It does not matter, of course, which two are found.

Figure 14-17 shows the corresponding PSpice circuit for determining the open-circuit voltage. Following is the circuit file along with the open-circuit voltage from the output file.

CIRCUIT FILE FOR THE CIRCUIT OF FIG. 14-17

```
V1 1 0 AC 20 -40
R1 1 2 20
R2 2 3 14
V2 3 4
E1 4 0 5 0 3
C1 2 5 0.0625
F1 5 0 V2 2
R3 5 0 10
C2 5 0 0.125
.AC LIN 1 0.159155 0.159155
.PRINT AC VM(5) VP(5)
.END
```

 **** AC ANALYSIS

FREQ	VM(5)	VP(5)
1.592E-01	9.043E+00	-7.107E+01

So, $V_{Th} = 9.043/ -71.07^\circ \text{ V}$.

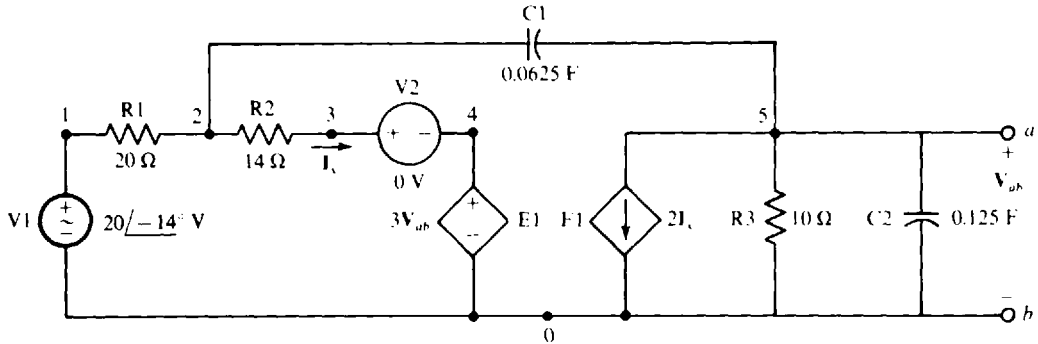

Fig. 14-17

Obtaining Z_{Th} directly requires deactivating the independent voltage source, which in turn requires changing the node 1 specification of resistor R1 to node 0. Also, a current source of $1/0$ A can be applied at the a - b terminals with the current directed into node a . Then, the voltage across this source has the same numerical value as Z_{Th} . Following is the modified circuit file along with the source voltage from the output file.

CIRCUIT FILE FOR THE CIRCUIT OF FIG. 14-17, MODIFIED

```

R1 0 2 20
R2 2 3 14
V2 3 4
E1 4 0 5 0 3
C1 2 5 0.0625
F1 5 0 V2 2
R3 5 0 10
C2 5 0 0.125
I1 0 5 AC 1
.AC LIN 1 0.159155 0.159155
.PRINT AC VM(5) VP(5)
.END
    
```

```

*****
****      AC ANALYSIS
*****

      FREQ          VM(5)          VP(5)
1.592E-01    7.920E+00    -1.602E+02
    
```

So, $Z_{Th} = 7.920 \angle -160.2 \Omega$.

14.15 What is the maximum average power that can be drawn from an ac generator that has an internal impedance of $150 \angle 60 \Omega$ and an rms open-circuit voltage of 12.5 kV? Do not be concerned about whether the generator power rating may be exceeded.

The maximum average power will be absorbed by a load that is the conjugate of the internal impedance, which is also the Thévenin impedance. The formula for this power is $P_{max} = V_{Th}^2 / 4R_{Th}$. Here, $V_{Th} = 12.5$ kV and $R_{Th} = 150 \cos 60 = 75 \Omega$. So,

$$P_{max} = \frac{(12.5 \times 10^3)^2}{4(75)} \text{ W} = 521 \text{ kW}$$

14.16 A signal generator operating at 2 MHz has an rms open-circuit voltage of 0.5 V and an internal impedance of $50 \angle 30 \Omega$. If it energizes a capacitor and parallel resistor, find the capacitance and

resistance of these components for maximum average power absorption by this resistor. Also, find this power.

The load that absorbs maximum average power has an impedance Z_L , that is the conjugate of the internal impedance of the generator. So, $Z_L = 50/\underline{-30} \Omega$ since the conjugate has the same magnitude and an angle that differs only in sign. Being in parallel, the load resistor and capacitor can best be determined from the load admittance, which is

$$Y_L = \frac{1}{Z_L} = \frac{1}{50/\underline{-30}} = 0.02/\underline{30} \text{ S} = 17.3 + j10 \text{ mS}$$

But $Y_L = G + j\omega C$ in which $\omega = 2\pi f = 2\pi(2 \times 10^6) \text{ rad/s} = 12.6 \text{ Mrad/s}$

So $G = \frac{1}{R} = 17.3 \text{ mS}$ from which $R = \frac{1}{17.3 \times 10^{-3}} = 57.7 \Omega$

and $j\omega C = j(12.6 \times 10^6)C = j10 \times 10^{-3} \text{ S}$ from which $C = \frac{10 \times 10^{-3}}{12.6 \times 10^6} \text{ F} = 796 \text{ pF}$

The maximum average power absorbed by the 57.7- Ω resistor can be found from $P_{\max} = V_{\text{Th}}^2/4R_{\text{Th}}$ in which R_{Th} is the resistance of $50/\underline{30} = 43.3 + j25 \Omega$:

$$P_{\max} = \frac{0.5^2}{4(43.3)} \text{ W} = 1.44 \text{ mW}$$

Of course, 43.3 Ω is used instead of the 57.7 Ω of the load resistor because 43.3 Ω is the Thévenin resistance of the source as well as the resistance of the impedance of the parallel resistor-capacitor load.

14.17 For the circuit shown in Fig. 14-18, what load impedance Z_L absorbs maximum average power, and what is this power?

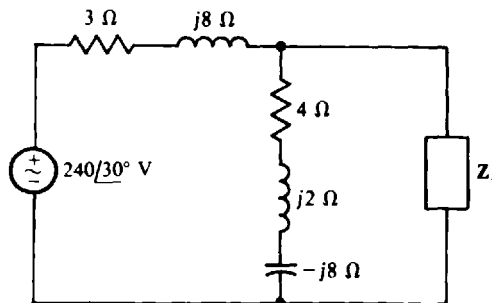

Fig. 14-18

The Thévenin equivalent of the source circuit at the load terminals is needed. By voltage division,

$$V_{\text{Th}} = \frac{4 + j2 - j8}{4 + j2 - j8 + 3 + j8} \times 240/\underline{30}^\circ = 237.7/\underline{-42.3}^\circ \text{ V}$$

The Thévenin impedance is

$$Z_{\text{Th}} = \frac{(3 + j8)(4 + j2 - j8)}{3 + j8 + 4 + j2 - j8} = \frac{60 + j14}{7 + j2} = 8.46/\underline{-2.81}^\circ \Omega$$

For maximum average power absorption, $Z_L = Z_{\text{Th}}^* = 8.46/\underline{2.81}^\circ \Omega$, the resistive part of which is $R_{\text{Th}} = 8.46 \cos 2.81 = 8.45 \Omega$. Finally, the maximum average power absorbed is

$$P_{\max} = \frac{V_{\text{Th}}^2}{4R_{\text{Th}}} = \frac{237.7^2}{4(8.45)} \text{ W} = 1.67 \text{ kW}$$

14.18 In the circuit shown in Fig. 14-19, find R and L for maximum average power absorption by the parallel resistor and capacitor load, and also find this power.

A good first step is to find the load impedance. Since the impedance of the capacitor is

$$jX_C = \frac{-j1}{\omega C} = \frac{-j1}{10^6(0.1 \times 10^{-6})} = -j10 \Omega$$

the impedance of the load is

$$Z_L = \frac{8(-j10)}{8 - j10} = 4.88 - j3.9 \Omega$$

Since for maximum average power absorption there should be no reactance limiting the current to the resistive part of the load, the inductance L should be selected such that its inductive reactance cancels the capacitive reactance of the load. So, $\omega L = 3.9 \Omega$, from which $L = 3.9 \times 10^{-6} \text{ H} = 3.9 \mu\text{H}$. With the cancellation of the reactances, the circuit is essentially the voltage source, the resistance R , and the 4.88Ω of the load, all in series. As should be apparent, for maximum average power absorption by the 4.88Ω of the load, the source resistance should be zero: $R = 0 \Omega$. Then, all the source voltage is across the 4.88Ω and the power absorbed is

$$P_{\max} = \frac{(45 \sqrt{2})^2}{4.88} = 208 \text{ W}$$

Notice that the source impedance is not the conjugate of the load impedance. The reason is that here the load resistance is fixed while the source resistance is a variable. The conjugate result occurs in the much more common situation in which the load impedance can be varied but the source impedance is fixed.

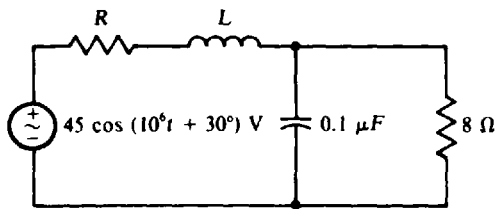

Fig. 14-19

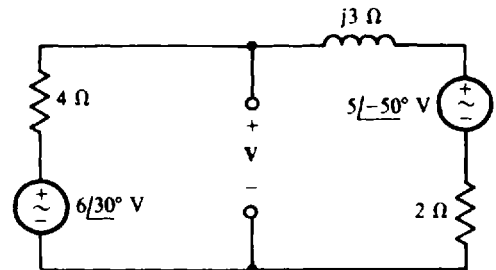

Fig. 14-20

14.19 Use superposition to find V in the circuit shown in Fig. 14-20.

The voltage V can be considered to have a component V' from the $6/30^\circ$ -V source and another component V'' from the $5/-50^\circ$ -V source such that $V = V' + V''$. The component V' can be found by using voltage division after replacing the $5/-50^\circ$ -V source with a short circuit:

$$V' = \frac{2 + j3}{2 + j3 + 4} \times 6/30 = 3.22/59.7^\circ \text{ V}$$

Similarly, V'' can be found by using voltage division after replacing the $6/30^\circ$ -V source with a short circuit:

$$V'' = \frac{4}{2 + j3 + 4} \times 5/-50 = 2.98/-76.6^\circ \text{ V}$$

Adding,

$$V = V' + V'' = 3.22/59.7^\circ + 2.98/-76.6^\circ = 2.32/-2.82^\circ \text{ V}$$

14.20 Use superposition to find i in the circuit shown in Fig. 14-21.

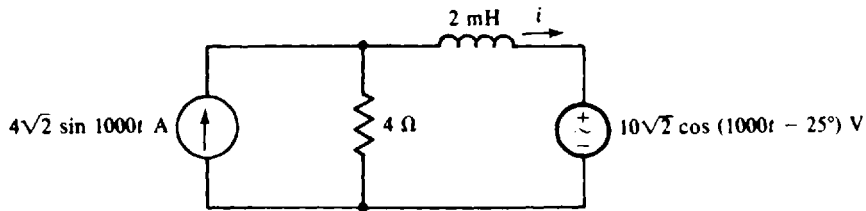

Fig. 14-21

It is necessary to construct the corresponding phasor-domain circuit, as shown in Fig. 14-22. The current \mathbf{I} can be considered to have a component \mathbf{I}' from the current source and a component \mathbf{I}'' from the voltage source such that $\mathbf{I} = \mathbf{I}' + \mathbf{I}''$. The component \mathbf{I}' can be found by using current division after replacing the voltage source with a short circuit:

$$\mathbf{I}' = \frac{4}{4 + j2} \times 4/0 = 3.58/-26.6 \text{ A}$$

And \mathbf{I}'' can be found by using Ohm's law after replacing the current source with an open circuit:

$$\mathbf{I}'' = -\frac{10/65}{4 + j2} = -2.24/38.4 \text{ A}$$

The negative sign is necessary because the voltage and current references are not associated. Adding.

$$\mathbf{I} = \mathbf{I}' + \mathbf{I}'' = 3.58/-26.6 - 2.24/38.4 = 3.32/-64.2 \text{ A}$$

Finally, the corresponding sinusoidal current is

$$i = \sqrt{2}(3.32) \sin(1000t - 64.2) = 4.7 \sin(1000t - 64.2) \text{ A}$$

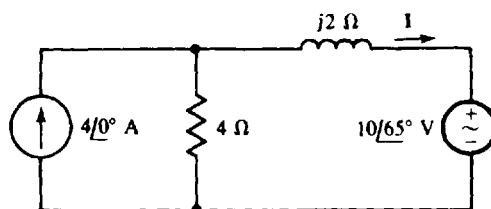

Fig. 14-22

14.21 Use superposition to find i for the circuit shown in Fig. 14-21 if the voltage of the voltage source is changed to $10\sqrt{2} \cos(2000t - 25^\circ) \text{ V}$.

The current i can be considered to have a component i' from the current source and a component i'' from the voltage source. Because these two sources have different frequencies, two different phasor-domain circuits are necessary. The phasor-domain circuit for the current source is the same as that shown in Fig. 14-22, but with the voltage source replaced by a short circuit. As a result, the current phasor \mathbf{I}' is the same as that found in the solution to Prob. 14.20: $\mathbf{I}' = 3.58/-26.6 \text{ A}$. The corresponding current is

$$i = \sqrt{2}(3.58) \sin(1000t - 26.6) = 5.06 \sin(1000t - 26.6) \text{ A}$$

The phasor-domain circuit for the voltage source and $\omega = 2000$ rad/s is shown in Fig. 14-23. By Ohm's law,

$$\mathbf{I}'' = -\frac{10\angle 65^\circ}{4 + j4} = -1.77\angle 20^\circ \text{ A}$$

from which $i'' = \sqrt{2}(-1.77) \sin(2000t + 20^\circ) = -2.5 \sin(2000t + 20^\circ) \text{ A}$

Finally, $i = i' + i'' = 5.06 \sin(1000t - 26.6^\circ) - 2.5 \sin(2000t + 20^\circ) \text{ A}$

Notice in this solution that the phasors \mathbf{I}' and \mathbf{I}'' cannot be added, as they could be in the solution to Prob. 14-20. The reason is that here the phasors are for different frequencies, while in the solution to Prob. 14-20 they are for the same frequency. When the phasors are for different frequencies, the corresponding sinusoids must be found first, and then these added. Also, the sinusoids cannot be combined into a single term.

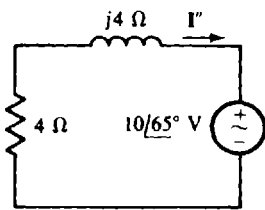

Fig. 14-23

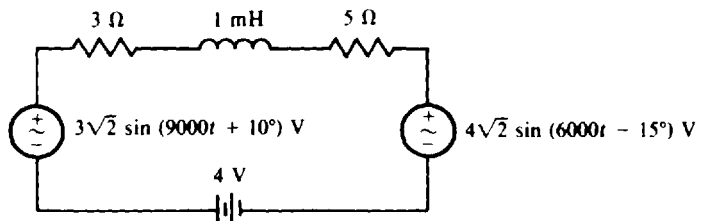

Fig. 14-24

- 14.22** Although superposition does not usually apply to power calculations, it does apply to the calculation of *average* power absorbed when all sources are sinusoids of *different* frequencies. (A dc source can be considered to be a sinusoidal source of zero frequency.) Use this fact to find the average power absorbed by the 5- Ω resistor in the circuit shown in Fig. 14-24.

Consider first the dc component of average power absorbed by the 5- Ω resistor. Of course, for this calculation the ac voltage sources are replaced by short circuits. Also, the inductor is replaced by a short circuit because an inductor is a short circuit to dc. So,

$$I_{\text{dc}} = \frac{4}{3 + 5} = 0.5 \text{ A}$$

This 0.5-A current produces a power dissipation in the 5- Ω resistor of $P_{\text{dc}} = 0.5^2(5) = 1.25 \text{ W}$.

The rms current from the 6000-rad/s voltage source is, by superposition,

$$I_{6000} = \frac{|4\angle -15^\circ|}{|3 + j6 + 5|} = \frac{4}{10} = 0.4 \text{ A}$$

It produces a power dissipation of $P_{6000} = 0.4^2(5) = 0.8 \text{ W}$ in the 5- Ω resistor. And the rms current from the 9000-rad/s voltage source is

$$I_{9000} = \frac{|3\angle 10^\circ|}{|3 + j9 + 5|} = \frac{3}{12.04} = 0.249 \text{ A}$$

It produces a power dissipation of $P_{9000} = 0.249^2(5) = 0.31 \text{ W}$ in the 5- Ω resistor.

The total average power P_{av} absorbed is the sum of these powers:

$$P_{\text{av}} = P_{\text{dc}} + P_{6000} + P_{9000} = 1.25 + 0.8 + 0.31 = 2.36 \text{ W}$$

- 14.23** Use superposition to find \mathbf{V} in the circuit shown in Fig. 14-25.

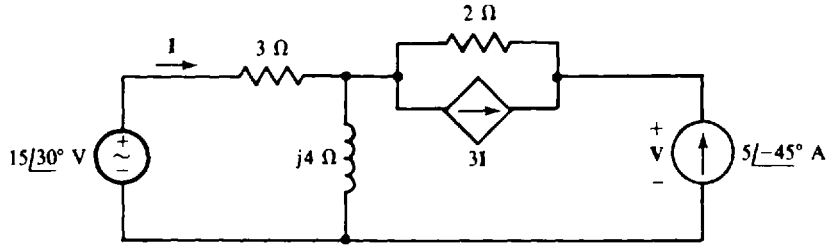

Fig. 14-25

If the independent current source is replaced by an open circuit, the circuit is as shown in Fig. 14-26, in which V' is the component of V from the voltage source. Because of the open-circuited terminals, no part of I can flow through the $2\text{-}\Omega$ resistor and the $3I$ dependent current source. Instead, all of I flows through the $j4\text{-}\Omega$ impedance as well as through the $3\text{-}\Omega$ resistance. Thus,

$$I = \frac{15\angle 30^\circ}{3 + j4} = 3\angle -23.1^\circ \text{ A}$$

With this I known, V' can be found from the voltage drops across the 2- and $j4\text{-}\Omega$ impedances:

$$V' = V_1 + V_2 = 2(3I) + j4I = (6 + j4)(3\angle -23.1^\circ) = 21.6\angle 10.6^\circ \text{ V}$$

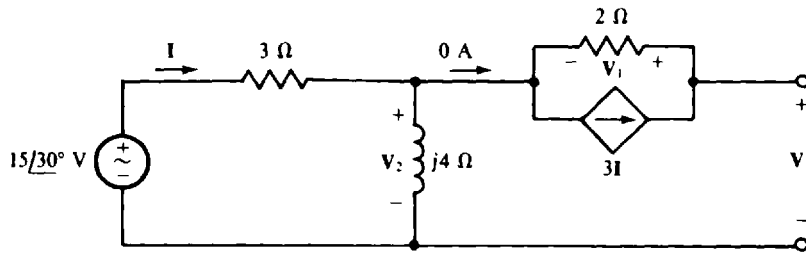

Fig. 14-26

If the voltage source in the circuit of Fig. 14-25 is replaced by a short circuit, the circuit is as shown in Fig. 14-27, where V'' is the component of V from the independent current source. As a reminder, the current to the left of the parallel resistor and dependent-source combination is shown as $5\angle -45^\circ \text{ A}$, the same as the independent source current, as it must be. Because this current flows into the parallel $3\text{-}\Omega$ and $j4\text{-}\Omega$ combination, the current I in the $3\text{-}\Omega$ resistor can be found by current division:

$$I = -\frac{j4}{3 + j4} \times 5\angle -45^\circ = 4\angle -188.1^\circ \text{ A}$$

With I known, V'' can be found from the voltage drops V_1 and V_2 across the $2\text{-}\Omega$ resistor and the parallel $3\text{-}\Omega$ and $j4\text{-}\Omega$ impedances. Since the $2\text{-}\Omega$ resistor current is $3I + 5\angle -45^\circ$,

$$V_1 = [3(4\angle -188.1^\circ) + 5\angle -45^\circ](2) = -17.1\angle 12.4^\circ \text{ V}$$

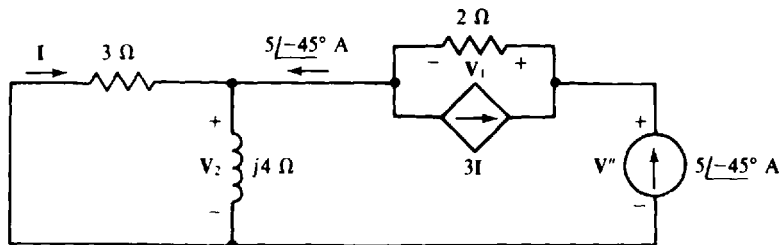

Fig. 14-27

Also, since the current in the $3\text{-}\Omega$ and $j4\text{-}\Omega$ parallel combination is $5\angle -45^\circ$ A,

$$V_2 = \frac{3(j4)}{3 + j4} \times 5\angle -45^\circ = 12\angle -8.1^\circ \text{ V}$$

So $V'' = V_1 + V_2 = -17.1\angle 12.4^\circ + 12\angle -8.1^\circ = 7.21\angle -132^\circ$ V

Finally, by superposition,

$$V = V' + V'' = 21.6\angle 10.6^\circ + 7.21\angle -132^\circ = 16.5\angle -4.89^\circ \text{ V}$$

The main purpose of this problem is to illustrate the fact that dependent sources are not deactivated in using superposition. Actually, using superposition on the circuit shown in Fig. 14-25 requires much more work than using loop or nodal analysis.

- 14.24** Transform the Δ shown in Fig. 14-28a to the Y in Fig. 14-28b for (a) $Z_1 = Z_2 = Z_3 = 12\angle 36^\circ \Omega$, and (b) $Z_1 = 3 + j5 \Omega$, $Z_2 = 6\angle 20^\circ \Omega$, and $Z_3 = 4\angle -30^\circ \Omega$.

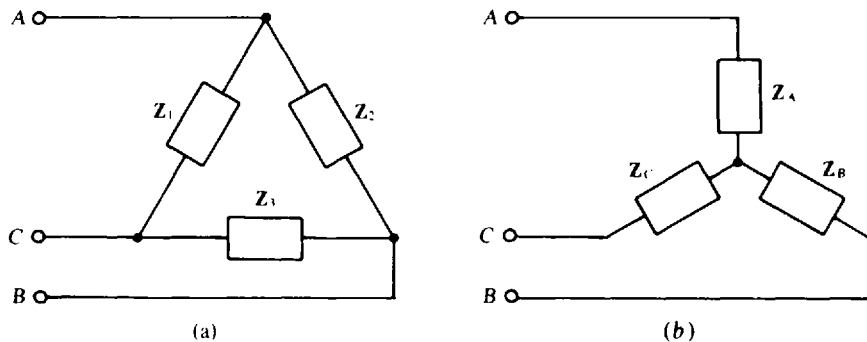

Fig. 14-28

- (a) Because all three Δ impedances are the same, all three Y impedances are the same and each is equal to one-third of the common Δ impedance:

$$Z_A = Z_B = Z_C = \frac{12\angle 36^\circ}{3} = 4\angle 36^\circ \Omega$$

- (b) All three Δ -to-Y transformation formulas have the same denominator, which is

$$Z_1 + Z_2 + Z_3 = (3 + j5) + 6\angle 20^\circ + 4\angle -30^\circ = 13.1\angle 22.66^\circ \Omega$$

By these formulas,

$$Z_A = \frac{Z_1 Z_2}{Z_1 + Z_2 + Z_3} = \frac{(3 + j5)(6\angle 20^\circ)}{13.1\angle 22.66^\circ} = 2.67\angle 56.4^\circ \Omega$$

$$Z_B = \frac{Z_2 Z_3}{Z_1 + Z_2 + Z_3} = \frac{(6\angle 20^\circ)(4\angle -30^\circ)}{13.1\angle 22.66^\circ} = 1.83\angle -32.7^\circ \Omega$$

$$Z_C = \frac{Z_1 Z_3}{Z_1 + Z_2 + Z_3} = \frac{(3 + j5)(4\angle -30^\circ)}{13.1\angle 22.66^\circ} = 1.78\angle 6.38^\circ \Omega$$

- 14.25** Transform the Y shown in Fig. 14-28b to the Δ in Fig. 14-28a for (a) $Z_A = Z_B = Z_C = 4 - j7 \Omega$, and (b) $Z_A = 10 \Omega$, $Z_B = 6 - j8 \Omega$, and $Z_C = 9\angle 30^\circ \Omega$.

- (a) Because all three Y impedances are the same, all three Δ impedances are the same and each is equal to three times the common Y impedance. So,

$$Z_1 = Z_2 = Z_3 = 3(4 - j7) = 12 - j21 = 24.2\angle -60.3^\circ \Omega$$

(b) All three Y-to-Δ transformation formulas have the same numerator, which here is

$$Z_A Z_B + Z_A Z_C + Z_B Z_C = 10(6 - j8) + 10(9/30) + (6 - j8)(9/30) = 231.6 \underline{-17.7}$$

By these formulas,

$$Z_1 = \frac{Z_A Z_B + Z_A Z_C + Z_B Z_C}{Z_B} = \frac{231.6 \underline{-17.7}}{6 - j8} = 23.2 \underline{35.4} \Omega$$

$$Z_2 = \frac{Z_A Z_B + Z_A Z_C + Z_B Z_C}{Z_C} = \frac{231.6 \underline{-17.7}}{9/30} = 25.7 \underline{-47.7} \Omega$$

$$Z_3 = \frac{Z_A Z_B + Z_A Z_C + Z_B Z_C}{Z_A} = \frac{231.6 \underline{-17.7}}{10} = 23.2 \underline{-17.7} \Omega$$

14.26 Using a Δ-to-Y transformation, find **I** for the circuit shown in Fig. 14-29.

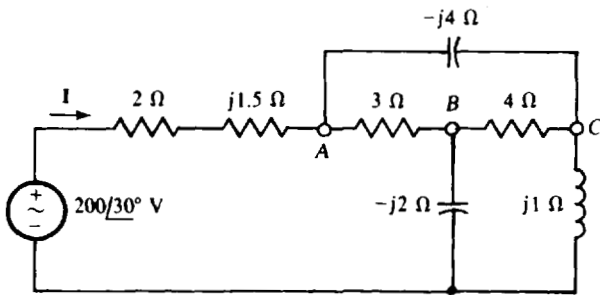

Fig. 14-29

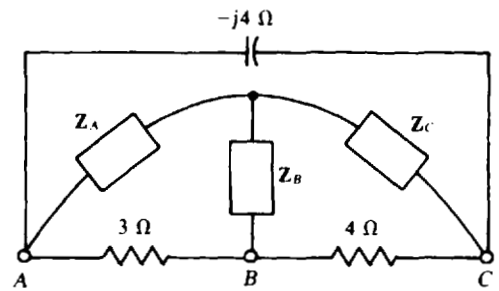

Fig. 14-30

Extending between nodes *A*, *B*, and *C* there is a Δ, as shown in Fig. 14-30, that can be transformed to the shown Y, with the result that the entire circuit becomes series-parallel and so can be reduced by combining impedances. The denominator of each Δ-to-Y transformation formula is $3 + 4 - j4 = 7 - j4 = 8.062 \underline{-29.7} \Omega$. And by these formulas,

$$Z_A = \frac{3(-j4)}{8.062 \underline{-29.7}} = 1.49 \underline{-60.3} \Omega \quad Z_B = \frac{3(4)}{8.062 \underline{-29.7}} = 1.49 \underline{29.7} \Omega$$

$$Z_C = \frac{4(-j4)}{8.062 \underline{-29.7}} = 1.98 \underline{-60.3} \Omega$$

With this Δ-to-Y transformation, the circuit is as shown in Fig. 14-31. Since this circuit is in series-parallel form, the input impedance Z_{in} can be found by circuit reduction. And then Z_{in} can be divided into the

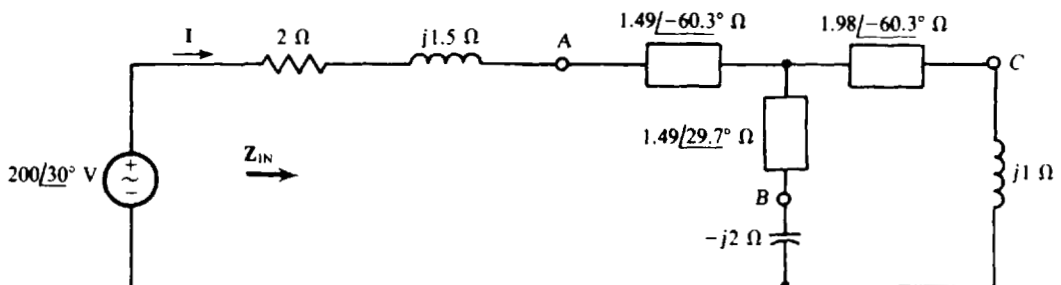

Fig. 14-31

applied voltage to get the current I :

$$Z_{in} = 2 + j1.5 + 1.49 \angle -60.3 + \frac{(1.49/29.7 - j2)(1.98 \angle -60.3 + j1)}{1.49/29.7 - j2 + 1.98 \angle -60.3 + j1} = 3.31 \angle -4.5 \Omega$$

Finally,

$$I = \frac{V}{Z_{in}} = \frac{200 \angle 30}{3.31 \angle -4.5} = 60.4 \angle 34.5 \text{ A}$$

Incidentally, the circuit shown in Fig. 14-29 can also be reduced to series-parallel form by transforming the Δ of the $-j2$ -, 4 -, and $j1$ - Ω impedances to a Y , or by transforming to a Δ either the Y of the 3 -, $-j2$ -, and 4 - Ω impedances or that of the $-j4$ -, 4 -, and $j1$ - Ω impedances.

14.27 Find the current I for the circuit shown in Fig. 14-32.

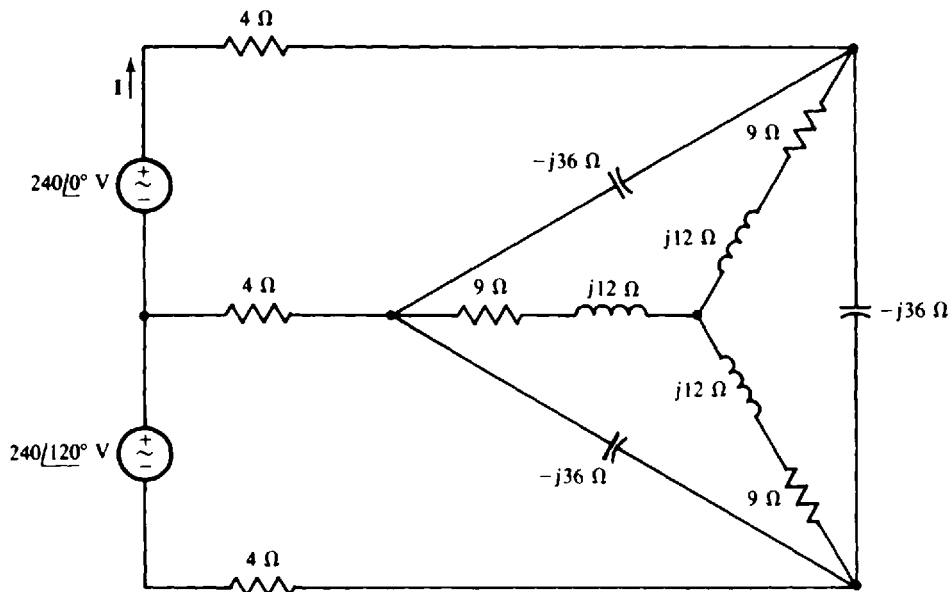

Fig. 14-32

As the circuit stands, a considerable number of mesh or nodal equations are required to find I . But the circuit, which has a Δ and a Y , can be reduced easily to just two meshes by using Δ - Y transformations. Although these transformations do not always lessen the work required, they do here because they are so simple as a result of the common impedances of the Y branches and also of the Δ branches.

One way to reduce the Δ - Y configuration is shown in Fig. 14-33. If the Y of $9 + j12$ - Ω impedances is transformed to a Δ , the result is a Δ of $3(9 + j12) = 27 + j36$ - Ω impedances in parallel with the $-j36$ - Ω impedances of the original Δ , as shown in Fig. 14-33a. Combining the parallel impedances produces a Δ with impedances of

$$\frac{(27 + j36)(-j36)}{27 + j36 - j36} = 48 - j36 \Omega$$

as shown in Fig. 14-33b. Then, if this is transformed to a Y , the Y has impedances of $(48 - j36)/3 = 16 - j12 \Omega$, as shown in Fig. 14-33c.

Figure 14-34 shows the circuit with this Y replacing the Δ - Y combination. The self-impedances of both meshes are the same: $4 + 16 - j12 - j12 + 16 + 4 = 40 - j24 \Omega$, and the mutual impedance is $20 - j12 \Omega$. So, the mesh equations are

$$\begin{aligned} (40 - j24)I - (20 - j12)I' &= 240 \angle 0^\circ \\ -(20 - j12)I + (40 - j24)I' &= 240 \angle 120^\circ \end{aligned}$$

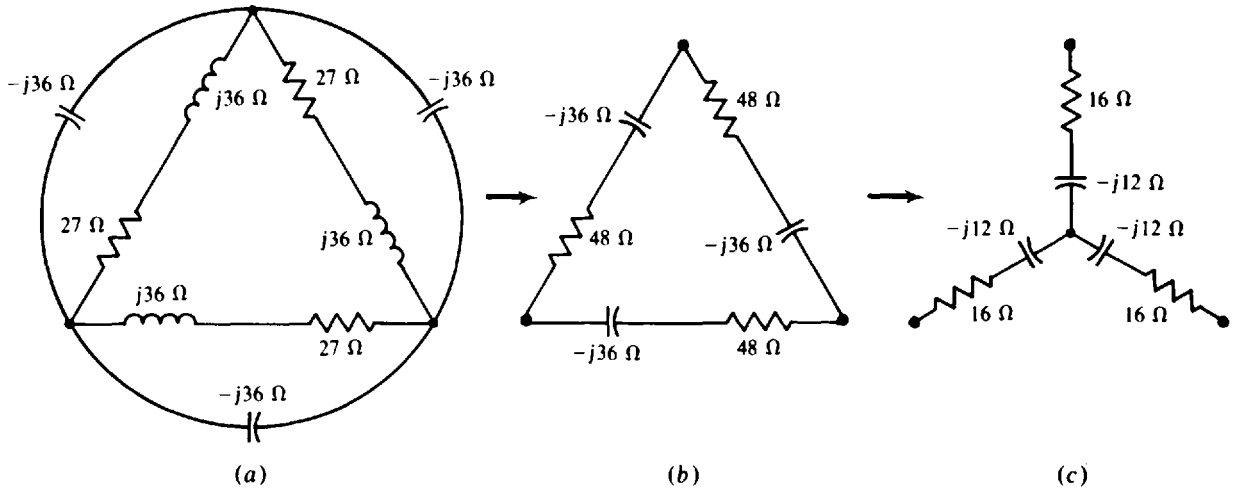

Fig. 14-33

By Cramer's rule,

$$I = \frac{\begin{vmatrix} 240/0 & -(20 - j12) \\ 240/120 & 40 - j24 \\ 40 - j24 & -(20 - j12) \\ -(20 - j12) & 40 - j24 \end{vmatrix}}{\begin{vmatrix} 40 - j24 & -(20 - j12) \\ -(20 - j12) & 40 - j24 \end{vmatrix}} = \frac{9696/-0.96}{1632/-61.93} = 5.94/61 \text{ A}$$

In reducing the Δ -Y circuit, it would have been easier to transform the Δ of $-j36\text{-}\Omega$ impedances to a Y of $-j36/3 = -j12\text{-}\Omega$ impedances. Then, although not obvious, the impedances of this Y would be in parallel with corresponding impedances of the other Y as a result of the two center nodes being at the same potential, which occurs because of equal impedance arms in each Y. If the parallel impedances are combined, the result is a Y of equal impedances of

$$\frac{-j12(9 + j12)}{-j12 + 9 + j12} = 16 - j12 \text{ }\Omega$$

the same as shown in Fig. 14-33c.

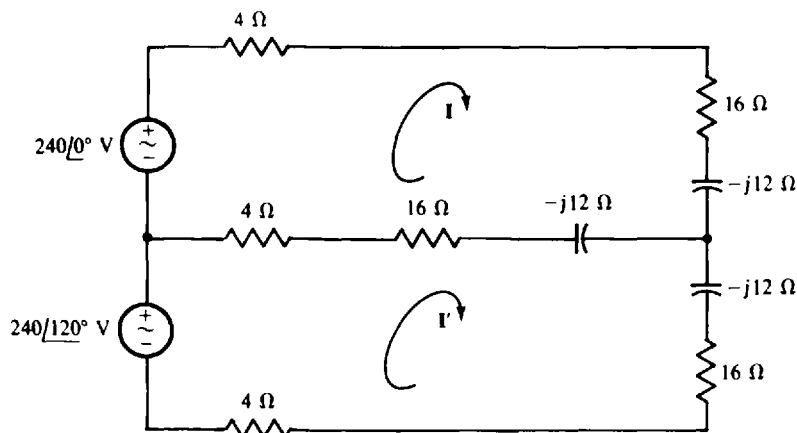

Fig. 14-34

14.28 Assume that the bridge circuit of Fig. 14-3 is balanced for $Z_1 = 5 \Omega$, $Z_2 = 4/30 \Omega$, and $Z_3 = 8.2 \Omega$, and for a source frequency of 2 kHz. If branch Z_X consists of two components in series, what are they?

The two components can be determined from the real and imaginary parts of Z_X . From the bridge balance equation,

$$Z_X = \frac{Z_2 Z_3}{Z_1} = \frac{(4/30)(8.2)}{5} = 6.56/30 = 5.68 + j3.28 \Omega$$

which corresponds to a 5.68- Ω resistor and a series inductor that has a reactance of 3.28 Ω . The corresponding inductance is

$$L = \frac{X_L}{\omega} = \frac{3.28}{2\pi(2000)} \text{ H} = 261 \mu\text{H}$$

14.29 The bridge circuit shown in Fig. 14-35 is a *capacitance comparison bridge* that is used for measuring the capacitance C_X of a capacitor and any resistance R_X inherent to the capacitor or in series with it. The bridge has a standard capacitor, the capacitance C_S of which is known. Find R_X and C_X if the bridge is in balance for $R_1 = 500 \Omega$, $R_2 = 2 \text{ k}\Omega$, $R_3 = 1 \text{ k}\Omega$, $C_S = 0.02 \mu\text{F}$, and a source radian frequency of 1 krad/s.

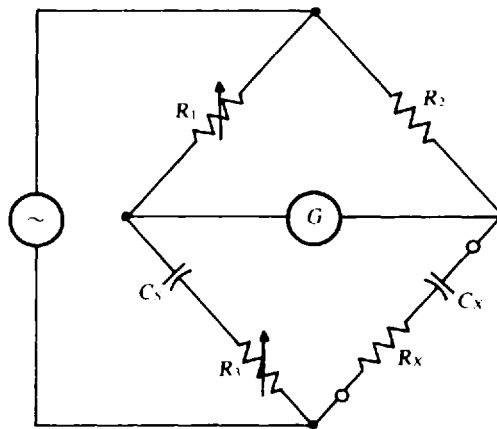

Fig. 14-35

The bridge balance equation can be used to determine R_X and C_X . From a comparison of Figs. 14-3 and 14-35, $Z_1 = 500 \Omega$, $Z_2 = 2000 \Omega$,

$$Z_3 = 1000 - \frac{j1}{1000(0.02 \times 10^{-6})} = 1000 - j50,000 \Omega$$

and

$$Z_X = R_X - \frac{j1}{1000C_X}$$

From the bridge balance equation $Z_X = Z_2 Z_3 / Z_1$,

$$R_X - \frac{j1}{1000C_X} = \frac{2000(1000 - j50,000)}{500} = 4000 - j200,000 \Omega$$

For two complex quantities in rectangular form to be equal, as here, both the real parts must be equal and the imaginary parts must be equal. This means that $R_X = 4000 \Omega$ and

$$\frac{1}{1000C_X} = -200,000 \quad \text{from which} \quad C_X = \frac{1}{1000(200,000)} \text{ F} = 5 \text{ nF}$$

14.30 For the capacitance comparison bridge shown in Fig. 14-35, derive general formulas for R_X and C_X in terms of the other bridge components.

For bridge balance, $Z_1 Z_X = Z_2 Z_3$, which in terms of the bridge components is

$$R_1 \left(R_X - \frac{j1}{\omega C_X} \right) = R_2 \left(R_3 - \frac{j1}{\omega C_3} \right) \quad \text{or} \quad R_1 R_X - j \frac{R_1}{\omega C_X} = R_2 R_3 - j \frac{R_2}{\omega C_3}$$

From equating real parts, $R_1 R_X = R_2 R_3$, or $R_X = R_2 R_3 / R_1$. And from equating imaginary parts, $-R_1 / (\omega C_X) = -R_2 / (\omega C_3)$, or $C_X = R_1 C_3 / R_2$.

14.31 The bridge circuit shown in Fig. 14-36, called a *Maxwell bridge*, is used for measuring the inductance and resistance of a coil in terms of a capacitance standard. Find L_X and R_X if the bridge is in balance for $R_1 = 500 \text{ k}\Omega$, $R_2 = 6.2 \text{ k}\Omega$, $R_3 = 5 \text{ k}\Omega$, and $C_5 = 0.1 \text{ }\mu\text{F}$.

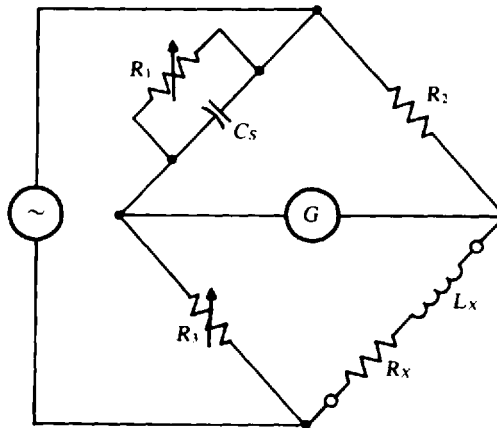

Fig. 14-36

First, general formulas will be derived for R_X and L_X in terms of the other bridge components. Then, values will be substituted into these formulas to find R_X and L_X for the specified bridge. From a comparison of Figs. 14-3 and 14-36, $Z_2 = R_2$, $Z_3 = R_3$, $Z_X = R_X + j\omega L_X$, and

$$Z_1 = \frac{R_1(-j1/\omega C_5)}{R_1 - j1/\omega C_5} = \frac{-jR_1}{R_1\omega C_5 - j1}$$

Substituting these into the bridge balance equation $Z_1 Z_X = Z_2 Z_3$ gives

$$\frac{-jR_1}{R_1\omega C_5 - j1} (R_X + j\omega L_X) = R_2 R_3$$

which, upon being multiplied by $R_1\omega C_5 - j1$ and simplified, becomes

$$R_1\omega L_X - jR_1 R_X = R_2 R_3 R_1\omega C_5 - jR_2 R_3$$

From equating real parts,

$$R_1\omega L_X = R_2 R_3 R_1\omega C_5 \quad \text{from which} \quad L_X = R_2 R_3 C_5$$

and from equating imaginary parts,

$$-R_1 R_X = -R_2 R_3 \quad \text{from which} \quad R_X = \frac{R_2 R_3}{R_1}$$

which are the general formulas for L_X and R_X . For the values of the specified bridge, these formulas give

$$R_X = \frac{(6.2 \times 10^3)(5 \times 10^3)}{500 \times 10^3} = 62 \text{ }\Omega \quad \text{and} \quad L_X = (6.2 \times 10^3)(5 \times 10^3)(0.1 \times 10^{-6}) = 3.1 \text{ H}$$

Supplementary Problems

14.32 Find V_{Th} and Z_{Th} for the Thévenin equivalent of the circuit shown in Fig. 14-37.

Ans. $133/-88.4$ V, $8.36/17.6$ Ω

14.33 What resistor will draw an 8-A rms current when connected across terminals a and b of the circuit shown in Fig. 14-37?

Ans. 8.44 Ω

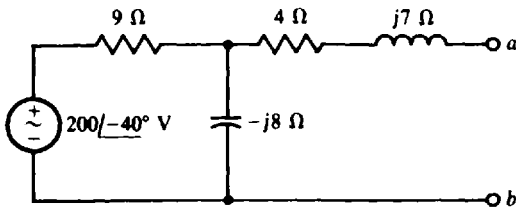

Fig. 14-37

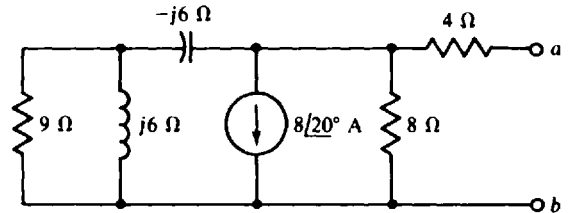

Fig. 14-38

14.34 Find I_N and Z_{Th} for the Norton equivalent of the circuit shown in Fig. 14-38.

Ans. $-3.09/5.07$ A, $6.3/-9.03$ Ω

14.35 Find V_{Th} and Z_{Th} for the Thévenin equivalent of the circuit shown in Fig. 14-39 for $R = 0$ Ω .

Ans. $3.47/123$ V, $3.05/29.2$ Ω

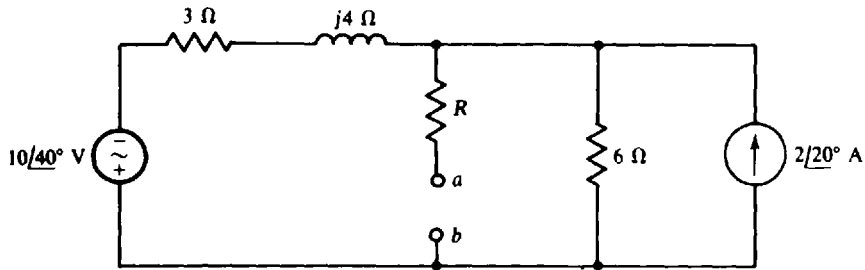

Fig. 14-39

14.36 Find I_N and Z_{Th} for the Norton equivalent of the circuit shown in Fig. 14-39 for $R = 2$ Ω .

Ans. $0.71/105^\circ$ A, $4.89/17.7$ Ω

14.37 Find V_{Th} and Z_{Th} for the Thévenin equivalent of the circuit shown in Fig. 14-40 for $R_1 = R_2 = 0$ Ω and $V_S = 0$ V.

Ans. $-40.4/-41.4$ V, $1.92/19.4$ Ω

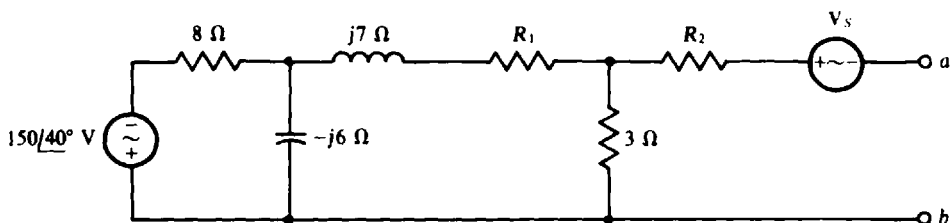

Fig. 14-40

14.38 Find V_{Th} and Z_{Th} for the Thévenin equivalent of the circuit shown in Fig. 14-40 for $R_1 = 5 \Omega$, $R_2 = 4 \Omega$, and $V_S = 50 \angle -60^\circ$ V.

Ans. $-71.5 \angle -50.2^\circ$ V, $6.24 \angle 2.03^\circ \Omega$

14.39 Find V_{Th} and Z_{Th} for the Thévenin equivalent of the circuit shown in Fig. 14-41.

Ans. $11.8 \angle 25.3^\circ$ V, $4.67 \angle 5.25^\circ \Omega$

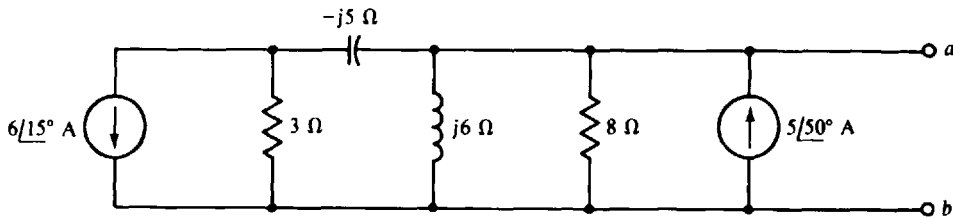

Fig. 14-41

14.40 What resistor will draw a 2-A rms current when connected across terminals a and b of the circuit shown in Fig. 14-41?

Ans. 1.21Ω

14.41 Using Thévenin's or Norton's theorem, find I for the bridge circuit shown in Fig. 14-42 if $I_S = 0$ A and $Z_L = 60 \angle 30^\circ \Omega$.

Ans. $10.4 \angle -43.5^\circ$ A

14.42 Find I for the bridge circuit shown in Fig. 14-42 if $I_S = 10 \angle 30^\circ$ A and $Z_L = 40 \angle -40^\circ \Omega$.

Ans. $15 \angle 6.3^\circ$ A

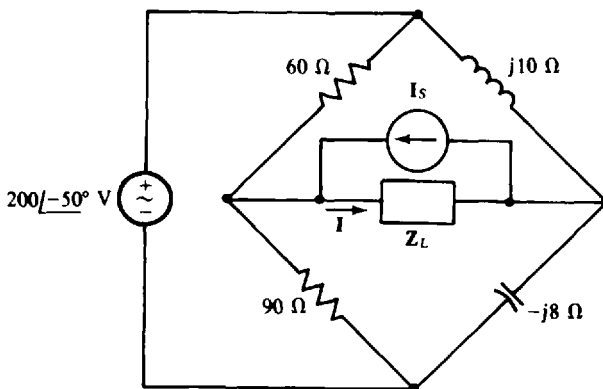

Fig. 14-42

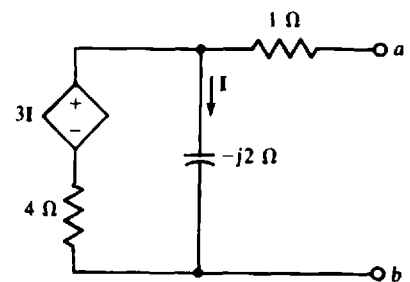

Fig. 14-43

14.43 Find the output impedance of the circuit shown in Fig. 14-43.

Ans. $4.49 \angle -20.9^\circ \Omega$

14.44 Find the output impedance of the circuit shown in Fig. 14-43 with the I reference direction reversed—being up instead of down.

Ans. $1.68 \angle -39.1^\circ \Omega$

14.45 Find V_{th} and Z_{th} for the Thévenin equivalent of the circuit shown in Fig. 14-44.

Ans. $-1.75 \angle 23^\circ$ V, $0.361 \angle 19.4^\circ \Omega$

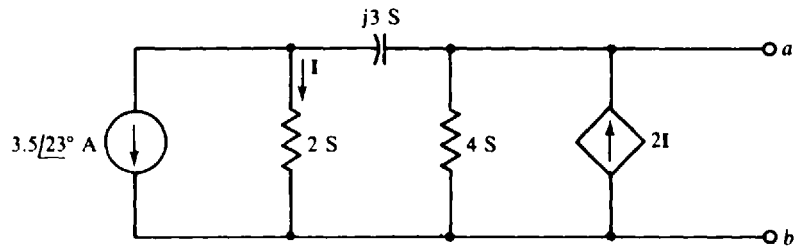

Fig. 14-44

14.46 In the circuit shown in Fig. 14-44, reverse the I reference direction—have it up instead of down—and find I_N and Z_{th} for the Norton equivalent circuit.

Ans. $4.85 \angle -70.2^\circ$ A, $0.116 \angle -18.8^\circ \Omega$

14.47 Find the output impedance at 10^4 rad/s of the circuit shown in Fig. 14-45.

Ans. $11.9 \angle -4.7^\circ$ k Ω

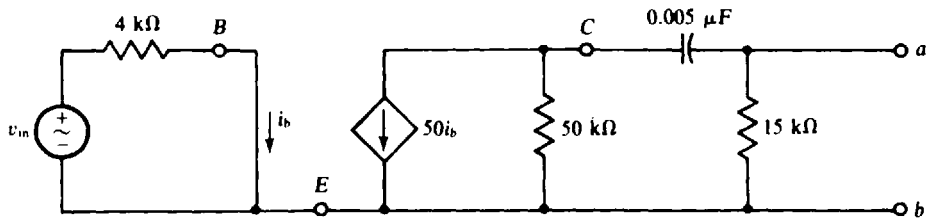

Fig. 14-45

14.48 Use PSpice to obtain the Thévenin equivalent at the a and b terminals of the phasor-domain circuit corresponding to the time-domain circuit of Fig. 14-46.

Ans. $5.23 \angle -10.5^\circ$ V, $110 \angle -21.7^\circ$ k Ω

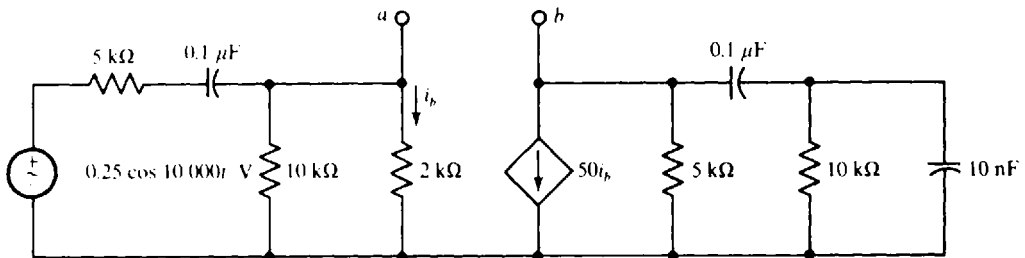

Fig. 14-46

14.49 What is the maximum average power that can be drawn from an ac generator that has an internal impedance of $100 \angle 20^\circ \Omega$ and an open-circuit voltage of 25 kV rms?

Ans. 1.66 MW

14.50 A signal generator operating at 5 MHz has an rms short-circuit current of 100 mA and an internal impedance of $80 \underline{-20} \Omega$. If it energizes a capacitor and a parallel resistor, find the capacitance and resistance for maximum average power absorption by the resistor. Also, find this power.

Ans. 136 pF, 85.1 Ω , 0.213 W

14.51 For the circuit shown in Fig. 14-47, what Z_L draws maximum average power and what is this power?

Ans. $12.8 \underline{-51.3} \Omega$, 48.5 W

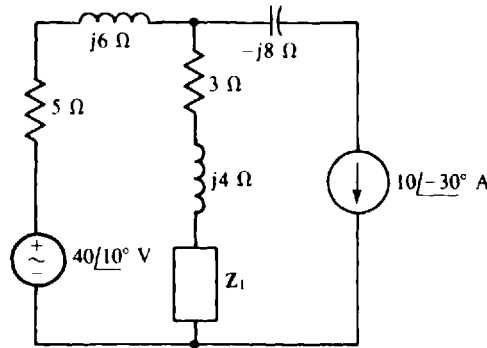

Fig. 14-47

14.52 In the circuit shown in Fig. 14-47, move the $-j8\text{-}\Omega$ impedance from in series with the current source to in parallel with it. Find the Z_L that absorbs maximum average power and find this power.

Ans. $14 \underline{-1.69} \Omega$, 61 W

14.53 Use superposition to find I for the circuit shown in Fig. 14-48.

Ans. $2.27 \underline{65.2} \text{ A}$

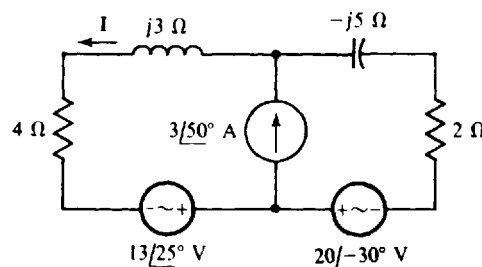

Fig. 14-48

14.54 For the circuit shown in Fig. 14-49, find the average power dissipated in the 3- Ω resistor using superposition and then without using superposition. Repeat this with the 10 phase angle changed to 40 for the one voltage source. (This problem illustrates the fact that superposition can be used to find the average power

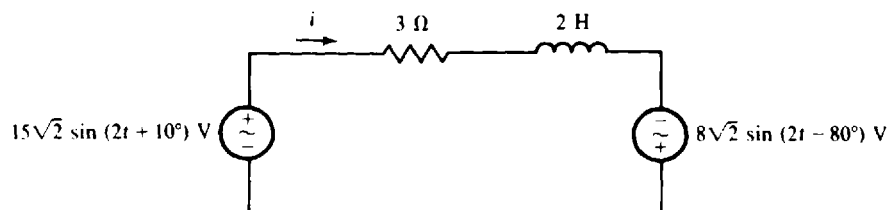

Fig. 14-49

absorbed by a resistor from two sources of the *same* frequency only if these sources produce resistor currents that have a 90° difference in phase angle.)

Ans. 34.7 W using superposition and without using superposition; an incorrect 34.7 W with superposition and a correct 20.3 W without using superposition

14.55 Find v for the circuit shown in Fig. 14-50.

Ans. $5.24 \sin(5000t - 61.6^\circ) - 4.39 \sin(8000t - 34.6^\circ)$ V

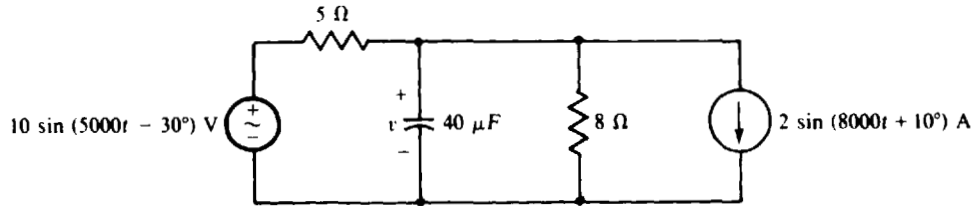

Fig. 14-50

14.56 Find the average power dissipated in the 5-Ω resistor of the circuit shown in Fig. 14-50.

Ans. 5.74 W

14.57 Find i for the circuit shown in Fig. 14-51.

Ans. $-2 \sin(5000t + 23.1^\circ) - 4.96 \sin(10^4t - 2.87^\circ)$ A

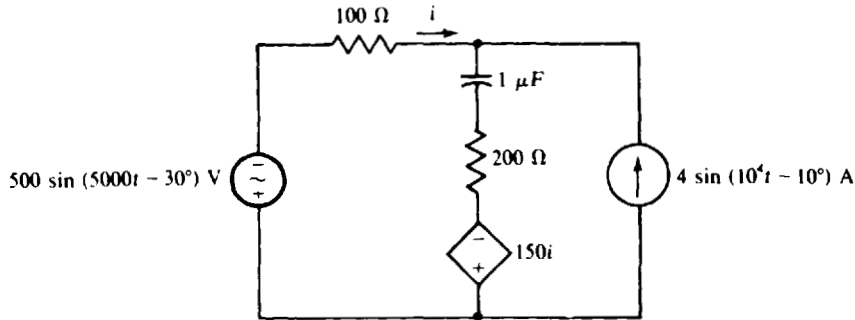

Fig. 14-51

14.58 Find the average power absorbed by the 200-Ω resistor in the circuit shown in Fig. 14-51.

Ans. 523 W

14.59 Transform the T shown in Fig. 14-52a to the Π in Fig. 14-52b for (a) $Z_A = Z_B = Z_C = 10 \angle -50^\circ \Omega$, and (b) $Z_A = 5 \angle -30^\circ \Omega$, $Z_B = 6 \angle 40^\circ \Omega$, $Z_C = 6 - j7 \Omega$.

Ans. (a) $Z_1 = Z_2 = Z_3 = 30 \angle -50^\circ \Omega$; (b) $Z_1 = 17.5 \angle -68^\circ \Omega$, $Z_2 = 11.4 \angle 21.4^\circ \Omega$, $Z_3 = 21 \angle 2.05^\circ \Omega$

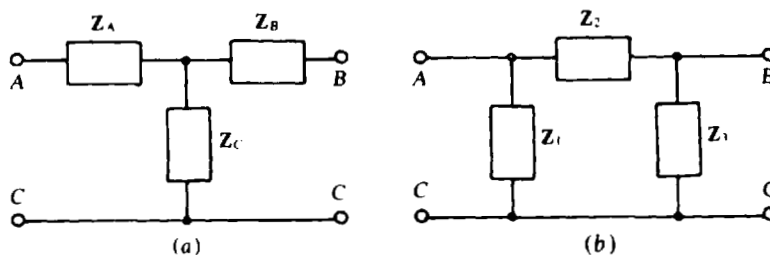

Fig. 14-52

14.60 Transform the Π shown in Fig. 14-52b to the T in Fig. 14-52a for (a) $Z_1 = Z_2 = Z_3 = 36\angle -24^\circ \Omega$, and (b) $Z_1 = 15\angle -24^\circ \Omega$, $Z_2 = 14 - j20 \Omega$, $Z_3 = 10 + j16 \Omega$.

Ans. (a) $Z_A = Z_B = Z_C = 12\angle -24^\circ \Omega$; (b) $Z_A = 9.38\angle -64^\circ \Omega$, $Z_B = 11.8\angle 18^\circ \Omega$, $Z_C = 7.25\angle 49^\circ \Omega$

14.61 Using a Δ -Y transformation, find I for the circuit shown in Fig. 14-53.

Ans. $26.9\angle 22^\circ \text{ A}$

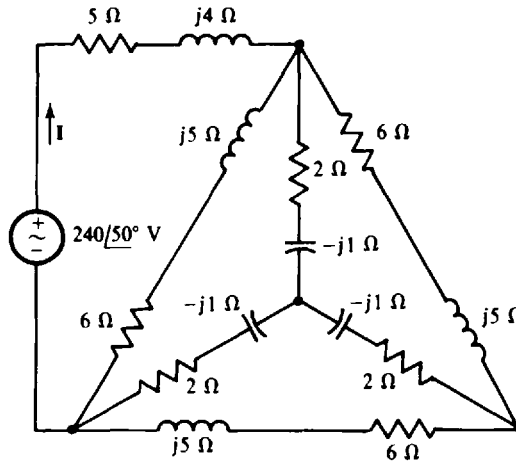

Fig. 14-53

14.62 Using a Δ -Y transformation, find I for the circuit shown in Fig. 14-54.

Ans. $17.6\angle 13.1^\circ \text{ A}$

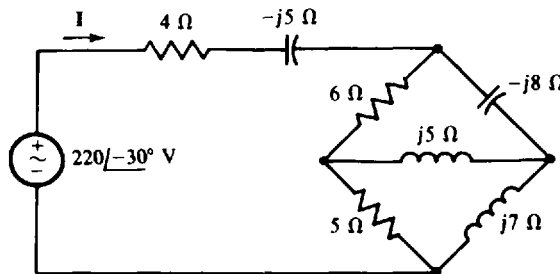

Fig. 14-54

14.63 Assume that the bridge circuit shown in Fig. 14-3 is balanced for $Z_1 = 10\angle -30^\circ \Omega$, $Z_2 = 15\angle 40^\circ \Omega$, and $Z_3 = 9.1 \Omega$, and for a source frequency of 5 kHz. If branch Z_x consists of two components in parallel, what are they?

Ans. A $39.9\text{-}\Omega$ resistor and a $462\text{-}\mu\text{H}$ inductor

14.64 Find C_x and R_x for the capacitor comparison bridge shown in Fig. 14-35 if this bridge is balanced for $R_1 = 1 \text{ k}\Omega$, $R_2 = 4 \text{ k}\Omega$, $R_3 = 2 \text{ k}\Omega$, and $C_5 = 0.1 \mu\text{F}$.

Ans. 25 nF , $8 \text{ k}\Omega$

14.65 Find L_x and R_x for the Maxwell bridge shown in Fig. 14-36 if this bridge is balanced for $R_1 = 50 \text{ k}\Omega$, $R_2 = 8.2 \text{ k}\Omega$, $R_3 = 4 \text{ k}\Omega$, and $C_5 = 0.05 \mu\text{F}$.

Ans. 1.64 H , 656Ω

Power in AC Circuits

INTRODUCTION

The major topic of this chapter is the *average* power absorbed over a period by ac components and circuits. Consequently, it will not be necessary to always use the adjective “*average*” with *power* to avoid misunderstanding. Also, it is not necessary to use the subscript notation “av” with the symbol P . Similarly, since the popular power formulas have only effective or rms values of voltage and current, the subscript notation “eff” can be deleted from V_{eff} and I_{eff} (or “rms” from V_{rms} and I_{rms}) and just the lightface V and I used to designate effective or rms values.

As a final introductory point, in the following text material and problems the specified voltages and currents always have associated references unless there are statements or designations to the contrary.

CIRCUIT POWER ABSORPTION

The average power absorbed by a two-terminal ac circuit can be derived from the instantaneous power absorbed. If the circuit has an applied voltage $v = V_m \sin(\omega t + \theta)$ and an input current $i = I_m \sin \omega t$, the *instantaneous* power absorbed by the circuit is

$$p = vi = V_m \sin(\omega t + \theta) \times I_m \sin \omega t = V_m I_m \sin(\omega t + \theta) \sin \omega t$$

This can be simplified by using the trigonometric identity

$$\sin A \sin B = \frac{1}{2}[\cos(A - B) - \cos(A + B)]$$

and the substitutions $A = \omega t + \theta$ and $B = \omega t$. The result is

$$p = \frac{V_m I_m}{2} [\cos \theta - \cos(2\omega t + \theta)]$$

Since

$$\frac{V_m I_m}{2} = \frac{V_m}{\sqrt{2}} \times \frac{I_m}{\sqrt{2}} = VI$$

the instantaneous power can be expressed as

$$p = VI \cos \theta - VI \cos(2\omega t + \theta)$$

The average value of this power is the sum of the average values of the two terms. The second term, being sinusoidal, has a zero average value over a period. The first term, though, is a constant, and so must be the average power absorbed by the circuit over a period. So,

$$P = VI \cos \theta$$

It is important to remember that in this formula the angle θ is the angle by which the input voltage leads the input current. For a circuit that does not contain any independent sources, this is the impedance angle.

For a purely resistive circuit, $\theta = 0$ and $\cos 0 = 1$ and so $P = VI \cos \theta = VI$. For a purely inductive circuit, $\theta = 90$ and $\cos \theta = \cos 90 = 0$, and so $P = 0 \text{ W}$, which means that a purely inductive circuit absorbs zero average power. The same is true for a purely capacitive circuit since, for it, $\theta = -90$ and $\cos(-90) = 0$.

The term “ $\cos \theta$ ” is called the *power factor*. It is often symbolized as PF, as in $P = VI \times \text{PF}$. The angle θ is called the *power factor angle*. As mentioned, it is often also the impedance angle.

The power factor angle has different signs for inductive and capacitive circuits, but since $\cos \theta = \cos(-\theta)$, the sign of the power factor angle has no effect on the power factor. Because the power factors

of inductive and capacitive circuits cannot be distinguished mathematically, they are distinguished by name. The power factor of an inductive circuit is called a *lagging power factor* and that of a capacitive circuit is called a *leading power factor*. These names can be remembered from the fact that for an inductive circuit the current *lags* the voltage, and for a capacitive circuit the current *leads* the voltage.

Another power formula can be obtained by substituting $V = IZ$ into $P = VI \cos \theta$:

$$P = VI \cos \theta = (IZ)I \cos \theta = I^2(Z \cos \theta) = I^2R$$

Of course, $R = Z \cos \theta$ is the input resistance, the same as the real part of the input impedance. The formula $P = I^2R$ may seem obvious from dc considerations, but remember that R is usually not the resistance of a physical resistor. Rather, it is the real part of the input impedance and is usually dependent on inductive and capacitive reactances as well as on resistances.

Similarly, with the substitution of $I = YV$,

$$P = VI \cos \theta = V(YV) \cos \theta = V^2(Y \cos \theta) = V^2G$$

in which $G = Y \cos \theta$ is the input conductance. In using this formula $P = V^2G$, remember that, except for a purely resistive circuit, the input conductance G is not the inverse of the input resistance R . If, however, V is the voltage across a resistor of R ohms, then $P = V^2G = V^2/R$.

WATTMETERS

Average power can be measured by an instrument called a *wattmeter*, as shown in Fig. 15-1. It has two pairs of terminals: a pair of voltage terminals on the left-hand side and a pair of current terminals on the right-hand side. The bottom terminal of each pair has a \pm designation for aiding in connecting up the wattmeter, as will be explained.

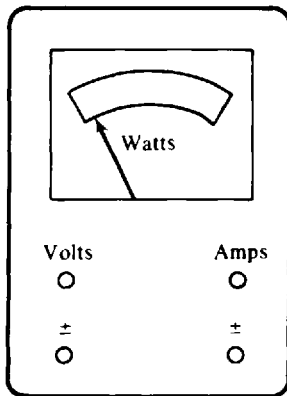

Fig. 15-1

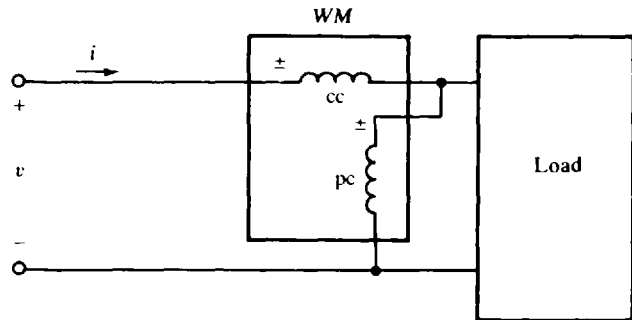

Fig. 15-2

For a measurement of power absorbed by a load, the voltage terminals are connected in parallel with the load and the current terminals are connected in series with the load. Because the voltage circuit inside the wattmeter has a very high resistance and the current circuit has a very low resistance, the voltage circuit can be considered an open circuit and the current circuit a short circuit for the power measurements of almost all loads. As a result, inserting a wattmeter in a circuit seldom has a significant effect on the power absorbed. For convenience, in circuit diagrams the voltage circuit will be shown as a coil labeled "pc" (for potential coil) and the current circuit will be shown as a coil labeled "cc" (for current coil), as shown in Fig. 15-2. One type of wattmeter, the electrodynamic wattmeter, actually has such coils.

The \pm designations help in making wattmeter connections so that the wattmeter reads upscale, to the right in Fig. 15-1, for positive absorbed power. A wattmeter will read upscale with the connection

in Fig. 15-2 if the load absorbs average power. Notice that, for the associated voltage and current references, the reference current enters the \pm current terminal and the positive reference of the voltage is at the \pm voltage terminal. The effect is the same, though, if both coils are reversed. If a load is active—a source of average power—then one coil connection, but not both, should be reversed for an upscale reading. Then, the wattmeter reading is considered to be negative for this connection. Incidentally, in the circuit shown in Fig. 15-2, the wattmeter reads essentially the same with the potential coil connected on the source side of the current coil instead of on the load side.

REACTIVE POWER

For industrial power considerations, a quantity called *reactive power* is often useful. It has the quantity symbol Q and the unit of *voltampere reactive*, the symbol for which is VAR. Reactive power, which is often referred to as *vars*, is defined as

$$Q = VI \sin \theta$$

for a two-terminal circuit with an input rms voltage V and an input rms current I . This Q is *absorbed* reactive power. The θ is the angle by which the input voltage leads the input current—the power factor angle. The quantity “ $\sin \theta$ ” is called the *reactive factor* of the load and has the symbol RF. Notice that it is negative for capacitive loads and is positive for inductive loads. A load that absorbs negative vars is considered to be producing vars—that is, it is a source of reactive power.

As was done for real power P , other formulas for Q can be found by substituting from $V = IZ$ and $I = YV$ into $Q = VI \sin \theta$. These formulas are

$$Q = I^2 X \quad \text{and} \quad Q = -V^2 B$$

where X is the reactance or imaginary part of the input impedance and B is the susceptance or imaginary part of the input admittance. (Remember that B is not the inverse of X .) Additionally, if V is the voltage across an inductor or capacitor with reactance X , then $Q = V^2/X$. So, $Q = V^2/\omega L$ for an inductor and $Q = -\omega CV^2$ for a capacitor.

COMPLEX POWER AND APPARENT POWER

There is a relation among the real power of a load, the reactive power, and another power called the *complex power*. For the derivation of this relation, consider the load impedance triangle shown in Fig. 15-3a. If each side is multiplied by the square of the rms current I to the load, the result is the triangle shown in Fig. 15-3b. Notice that this multiplication does not affect the impedance angle θ since each side is multiplied by the same quantity. The horizontal side is the real power $P = I^2 R$, the vertical side is jI times the reactive power, $jI^2 X = jQ$, and the hypotenuse $I^2 Z$ is the complex power of the load. Complex power has the quantity symbol S and the unit of *voltampere* with symbol VA. These power quantities are shown in Fig. 15-3c, which is known as the *power triangle*. From this triangle, clearly $S = P + jQ$.

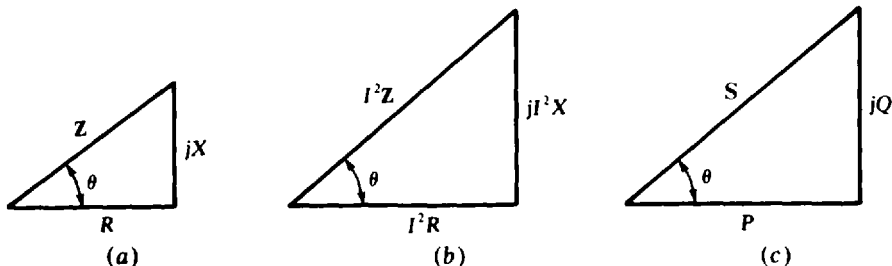

Fig. 15-3

The length of the hypotenuse $|\mathbf{S}| = S$, is called the *apparent power*. Its name comes from the fact that it is equal to the product of the input rms voltage and current:

$$S = |I^2\mathbf{Z}| = |\mathbf{IZ}| \times I = VI$$

and from the fact that in dc circuits this product VI is the power absorbed. The substitution of $V = IZ$ and $I = V/Z$ into $S = VI$ produces two other formulas: $S = I^2Z$ and $S = V^2/Z$.

The VI formula for apparent power leads to another popular formula for complex power. Since $\mathbf{S} = S/\theta$, and $S = VI$, then $\mathbf{S} = VI/\theta$.

A third formula for complex power is $\mathbf{S} = \mathbf{VI}^*$, where \mathbf{I}^* is the conjugate of the input current \mathbf{I} . This is a valid formula since the magnitude of \mathbf{VI}^* is the product of the applied rms voltage and current, and, consequently, is the apparent power. Also, the angle of this product is the angle of the voltage phasor *minus* the angle of the current phasor, with the subtraction occurring because of the use of the conjugate of the current phasor. This difference in angles is, of course, the complex power angle θ —the angle by which the input voltage leads the input current—and also the power factor angle.

One use of complex power is for obtaining the total complex power of several loads energized by the same source, usually in parallel. It can be shown that the total complex power is the sum of the individual complex powers, regardless of how the loads are connected. It follows that the total real power is the sum of the individual real powers, and that the total reactive power is the sum of the individual reactive powers. To repeat for emphasis: Complex powers, real powers, and reactive powers can be added to obtain the total complex power, real power, and reactive power, respectively. The same is *not* true for apparent powers. In general, apparent powers cannot be added to obtain a total apparent power any more than rms voltages or currents can be added to obtain a total rms voltage or current.

The total complex power can be used to find the total input current, as should be apparent from the fact that the magnitude of the total complex power, the apparent power, is the product of the input voltage and current. Another use for complex power is in power factor correction, which is the subject of the next section.

POWER FACTOR CORRECTION

In the consumption of a large amount of power, a large power factor is desirable—the larger the better. The reason is that the current required to deliver a given amount of power to a load is inversely proportional to the load power factor, as is evident from rearranging $P = VI \cos \theta$ to

$$I = \frac{P}{V \cos \theta} = \frac{P}{V \times \text{PF}}$$

So, for a given power P absorbed and applied voltage V , the smaller the power factor the greater the current I to the load. Larger than necessary currents are undesirable because of the accompanying larger voltage losses and I^2R power losses in power lines and other power distribution equipment.

As a practical matter, low power factors are always the result of inductive loads because almost all loads are inductive. From a power triangle viewpoint, the vars that such loads consume make the power triangle have a large vertical side and so a large angle θ . The result is a small $\cos \theta$, which is the power factor. Improving the power factor of a load requires adding capacitors across the power line at the load to provide the vars consumed by the inductive load. From another point of view, these capacitors supply current to the load inductors, which current, without the capacitors, would have to come over the power line. More accurately, there is a current interchange between these capacitors and the load inductors.

Although adding sufficient capacitance to increase the power factor to unity is possible, it may not be economical. For finding the minimum capacitance required to improve the power factor to the amount desired, the general procedure is to first calculate the initial number of vars Q_i being consumed by the load. This can be calculated from $Q_i = P \tan \theta_i$, which formula should be apparent from the power triangle shown in Fig. 15-3c. Of course, θ_i is the load impedance angle. The next step is to determine

the final impedance angle θ_f from the final desired power factor: $\theta_f = \cos^{-1} \text{PF}_f$. This angle is used in $Q_f = P \tan \theta_f$ to find the total number of vars Q_f for the combined load. This formula is valid since adding the parallel capacitor or capacitors does not change P . The next step is to find the vars that the added capacitors must provide: $\Delta Q = Q_f - Q_i$. Finally, ΔQ is used to find the required amount of capacitance:

$$\Delta Q = \frac{V^2}{X} = \frac{V^2}{-1/\omega C} = -\omega C V^2 \quad \text{from which} \quad C = -\frac{\Delta Q}{\omega V^2}$$

If ΔQ is defined as $Q_i - Q_f$, the negative sign can be eliminated in the formula for C ; then, $C = \Delta Q/\omega V^2$. All this procedure can be done in one step with

$$C = \frac{P[\tan(\cos^{-1} \text{PF}_i) - \tan(\cos^{-1} \text{PF}_f)]}{\omega V^2}$$

Although calculating the capacitance required for power factor correction may be a good academic exercise, it is not necessary on the job. Manufacturers specify their power factor correction capacitors by operating voltages and the kilovars the capacitors produce. So, for power factor correction, it is only necessary to know the voltages of the lines across which the capacitors will be placed and the kilovars required.

Solved Problems

- 15.1** The instantaneous power absorbed by a circuit is $p = 10 + 8 \sin(377t + 40^\circ) \text{ W}$. Find the maximum, minimum, and average absorbed powers.

The maximum value occurs at those times when the sinusoidal term is a maximum. Since this term has a maximum value of 8, $p_{\max} = 10 + 8 = 18 \text{ W}$. The minimum value occurs when the sinusoidal term is at its minimum value of -8 : $p_{\min} = 10 - 8 = 2 \text{ W}$. Because the sinusoidal term has a zero average value, the average power absorbed is $P = 10 + 0 = 10 \text{ W}$.

- 15.2** With $v = 300 \cos(20t + 30^\circ) \text{ V}$ applied, a circuit draws $i = 15 \cos(20t - 25^\circ) \text{ A}$. Find the power factor and also the average, maximum, and minimum absorbed powers.

The power factor of the circuit is the cosine of the power factor angle, which is the angle by which the voltage leads the current:

$$\text{PF} = \cos[30^\circ - (-25^\circ)] = \cos 55^\circ = 0.574$$

It is lagging because the current lags the voltage.

The average power absorbed is the product of the rms voltage and current and the power factor:

$$P = \frac{300}{\sqrt{2}} \times \frac{15}{\sqrt{2}} \times 0.574 = 1.29 \times 10^3 \text{ W} = 1.29 \text{ kW}$$

The maximum and minimum absorbed powers can be found from the instantaneous power, which is

$$p = vi = 300 \cos(20t + 30^\circ) \times 15 \cos(20t - 25^\circ) = 4500 \cos(20t + 30^\circ) \cos(20t - 25^\circ)$$

This can be simplified by using the trigonometric identity

$$\cos A \cos B = 0.5 [\cos(A + B) + \cos(A - B)]$$

and the substitutions $A = 20t + 30^\circ$ and $B = 20t - 25^\circ$. The result is

$$p = 4500 \times 0.5 [\cos(40t + 5^\circ) + \cos 55^\circ] = 2250 \cos(40t + 5^\circ) + 2250 \cos 55^\circ \text{ W}$$

Clearly, the maximum value occurs when the first cosine term is 1 and the minimum value when this term is -1 :

$$p_{\max} = 2250(1 + \cos 55^\circ) \text{ W} = 3.54 \text{ kW}$$

$$p_{\min} = 2250(-1 + \cos 55^\circ) = -959 \text{ W}$$

The negative minimum absorbed power indicates that the circuit is delivering power instead of absorbing it.

15.3 For each following load voltage and current pair find the corresponding power factor and average power absorbed:

(a) $v = 277\sqrt{2} \sin(377t + 30^\circ) \text{ V}$, $i = 5.1\sqrt{2} \sin(377t - 10^\circ) \text{ A}$

(b) $v = 679 \sin(377t + 50^\circ) \text{ V}$, $i = 13 \cos(377t + 10^\circ) \text{ A}$

(c) $v = -170 \sin(377t - 30^\circ) \text{ V}$, $i = 8.1 \cos(377t + 30^\circ) \text{ A}$

(a) Since the angle by which the voltage leads the current is $\theta = 30^\circ - (-10^\circ) = 40^\circ$, the power factor is $\text{PF} = \cos 40^\circ = 0.766$. It is lagging because the current lags the voltage, or, in other words, because the power factor angle θ is positive. The average power absorbed is the product of the rms voltage and current and the power factor:

$$P = VI \times \text{PF} = 277(5.1)(0.766) = 1.08 \times 10^3 \text{ W} = 1.08 \text{ kW}$$

(b) The power factor angle θ can be found by phase angle subtraction only if v and i have the same sinusoidal form, which they do not have here. The cosine term of i can be converted to the sine form of v by using the identity $\cos x = \sin(x + 90^\circ)$:

$$i = 13 \cos(377t + 10^\circ) = 13 \sin(377t + 10^\circ + 90^\circ) = 13 \sin(377t + 100^\circ) \text{ A}$$

So, the power factor angle is $\theta = 50^\circ - 100^\circ = -50^\circ$, and the power factor is $\text{PF} = \cos(-50^\circ) = 0.643$. It is a leading power factor because the current leads the voltage, and also because θ is negative, which is equivalent. The average power absorbed is

$$P = VI \times \text{PF} = \frac{679}{\sqrt{2}} \times \frac{13}{\sqrt{2}} \times 0.643 = 2.84 \times 10^3 \text{ W} = 2.84 \text{ kW}$$

(c) The voltage sinusoid will be put in the same sinusoidal form as the current sinusoid as an aid in finding θ . The negative sign can be eliminated by using $-\sin x = \sin(x \pm 180^\circ)$:

$$v = -170 \sin(377t - 30^\circ) = 170 \sin(377t - 30^\circ \pm 180^\circ)$$

Then the identity $\sin x = \cos(x - 90^\circ)$ can be used:

$$\begin{aligned} v &= 170 \sin(377t - 30^\circ \pm 180^\circ) = 170 \cos(377t - 30^\circ \pm 180^\circ - 90^\circ) \\ &= 170 \cos(377t - 120^\circ \pm 180^\circ) \end{aligned}$$

The positive sign of $\pm 180^\circ$ should be selected to make the voltage and current phase angles as close together as possible:

$$v = 170 \cos(377t - 120^\circ + 180^\circ) = 170 \cos(377t + 60^\circ) \text{ V}$$

So, $\theta = 60^\circ - 30^\circ = 30^\circ$, and the power factor is $\text{PF} = \cos 30^\circ = 0.866$. It is lagging because θ is positive. Finally, the average power absorbed is

$$P = VI \times \text{PF} = \frac{170}{\sqrt{2}} \times \frac{8.1}{\sqrt{2}} \times 0.866 = 596 \text{ W}$$

15.4 Find the power factor of a circuit that absorbs 1.5 kW for a 120-V input voltage and a 16-A current.

From $P = VI \times \text{PF}$, the power factor is

$$\text{PF} = \frac{P}{VI} = \frac{\text{average power}}{\text{apparent power}} = \frac{1500}{120(16)} = 0.781$$

There is not enough information given to determine whether this power factor is leading or lagging.

Note that the power factor is equal to the average power divided by the apparent power. Some authors of circuit analysis books use this for the definition of power factor because it is more general than $\text{PF} = \cos \theta$.

- 15.5** What is the power factor of a fully loaded 10-hp induction motor that operates at 80 percent efficiency while drawing 28 A from a 480-V line?

The motor power factor is equal to the power input divided by the apparent power input. And, the power input is the power output divided by the efficiency of operation:

$$P_{\text{in}} = \frac{P_{\text{out}}}{\eta} = \frac{10 \times 745.7}{0.8} \text{ W} = 9.321 \text{ kW}$$

in which 1 hp = 745.7 W is used. So,

$$\text{PF} = \frac{P_{\text{in}}}{VI} = \frac{9.321 \times 10^3}{480(28)} = 0.694$$

This power factor is lagging because induction motors are inductive loads.

- 15.6** Find the power absorbed by a load of $6/\underline{30}^\circ \Omega$ when 42 V is applied.

The rms current needed for the power formulas is equal to the rms voltage divided by the magnitude of the impedance: $I = 42/6 = 7 \text{ A}$. Of course, the power factor is the cosine of the impedance angle: $\text{PF} = \cos 30^\circ = 0.866$. Thus,

$$P = VI \times \text{PF} = 42(7)(0.866) = 255 \text{ W}$$

The absorbed power can also be obtained from $P = I^2 R$, in which $R = Z \cos \theta = 6 \cos 30^\circ = 5.2 \Omega$:

$$P = 7^2 \times 5.2 = 255 \text{ W}$$

The power cannot be found from $P = V^2/R$, as is evident from the fact that $V^2/R = 42^2/5.2 = 339 \text{ W}$, which is incorrect. The reason for the incorrect result is that the 42 V is across the entire impedance and not just the resistance part. For $P = V^2/R$ to be valid, the V used must be that across R .

- 15.7** What power is absorbed by a circuit that has an input admittance of $0.4 + j0.5 \text{ S}$ and an input current of 30 A?

The formula $P = V^2 G$ can be used after the input voltage V is found. It is equal to the current divided by the magnitude of the admittance:

$$V = \frac{I}{|Y|} = \frac{30}{|0.4 + j0.5|} = \frac{30}{0.64} = 46.85 \text{ V}$$

So
$$P = V^2 G = (46.85)^2 0.4 = 878 \text{ W}$$

Alternatively, the power formula $P = VI \cos \theta$ can be used. The power factor angle θ is the negative of the admittance angle: $\theta = -\tan^{-1}(0.5/0.4) = -51.34^\circ$. So,

$$P = VI \cos \theta = 46.85(30) \cos(-51.34^\circ) = 878 \text{ W}$$

- 15.8** A resistor in parallel with a capacitor absorbs 20 W when the combination is connected to a 240-V, 60-Hz source. If the power factor is 0.7 leading, what are the resistance and capacitance?

The resistance can be found by solving for R in $P = V^2/R$:

$$R = \frac{V^2}{P} = \frac{240^2}{20} \Omega = 2.88 \text{ k}\Omega$$

One way to find the capacitance is from the susceptance B , which can be found from $B = G \tan \phi$ after the conductance G and admittance angle ϕ are known. The conductance is

$$G = \frac{1}{R} = \frac{1}{2.88 \times 10^3} = 0.347 \times 10^{-3} \text{ S}$$

For this capacitive circuit, the admittance angle is the negative of the power factor angle: $\phi = -(-\cos^{-1} 0.7) = 45.6^\circ$. So,

$$B = G \tan \phi = 0.347 \times 10^{-3} \tan 45.6^\circ = 0.354 \times 10^{-3} \text{ S}$$

Finally, since $B = \omega C$,

$$C = \frac{B}{\omega} = \frac{0.354 \times 10^{-3}}{2\pi(60)} = 0.94 \mu\text{F}$$

- 15.9** A resistor in series with a capacitor absorbs 10 W when the combination is connected to a 120-V, 400-Hz source. If the power factor is 0.6 leading, what are the resistance and capacitance?

Because this is a series circuit, impedance should be used to find the resistance and capacitance. The impedance can be found by using the input current, which from $P = VI \times \text{PF}$ is

$$I = \frac{P}{V \times \text{PF}} = \frac{10}{120(0.6)} = 0.1389 \text{ A}$$

The magnitude of the impedance is equal to the voltage divided by the current, and the impedance angle is, for this capacitive circuit, the negative of the arccosine of the power factor:

$$\mathbf{Z} = \frac{V}{I} \angle -\cos^{-1} \text{PF} = \frac{120}{0.1389} \angle -\cos^{-1} 0.6 = 864 \angle -53.13^\circ = 518 - j691 \Omega$$

From the real part the resistance is $R = 518 \Omega$, and from the imaginary part and $X = -1/\omega C$, the capacitance is

$$C = -\frac{1}{\omega X} = \frac{-1}{2\pi(400)(-691)} = 0.576 \mu\text{F}$$

- 15.10** If a coil draws 0.5 A from a 120-V, 60-Hz source at a 0.7 lagging power factor, what are the coil resistance and inductance?

The resistance and inductance can be obtained from the impedance. The impedance magnitude is $Z = V/I = 120/0.5 = 240 \Omega$, and the impedance angle is the power factor angle: $\theta = \cos^{-1} 0.7 = 45.57^\circ$. So, the coil impedance is $\mathbf{Z} = 240 \angle 45.57^\circ = 168 + j171.4 \Omega$. From the real part, the coil resistance is $R = 168 \Omega$, and from the imaginary part the coil reactance is 171.4Ω . The inductance can be found from $X = \omega L$. It is $L = X/\omega = 171.4/2\pi(60) = 0.455 \text{ H}$.

- 15.11** A resistor and parallel capacitor draw 0.2 A from a 24-V, 400-Hz source at a 0.8 leading power factor. Find the resistance and capacitance.

Since the components are in parallel, admittance should be used to find the resistance and capacitance. The admittance magnitude is $Y = I/V = 0.2/24 = 8.33 \text{ mS}$, and the admittance angle is, for this capacitive circuit, the arccosine of the power factor: $\cos^{-1} 0.8 = 36.9^\circ$. Thus, the admittance is

$$\mathbf{Y} = 8.33 \angle -36.9^\circ = 6.67 + j5 \text{ mS}$$

From the real part, the conductance of the resistor is 6.67 mS, and so the resistance is $R = 1/(6.67 \times 10^{-3}) = 150 \Omega$. From the imaginary part the capacitive susceptance is 5 mS, and so the capacitance is

$$C = \frac{B}{\omega} = \frac{5 \times 10^{-3}}{2\pi(400)} = 1.99 \mu\text{F}$$

- 15.12** Operating at maximum capacity, a 12 470-V alternator supplies 35 MW at a 0.7 lagging power factor. What is the maximum real power that the alternator can deliver?

The limitation on the alternator capacity is the maximum voltamperes—the apparent power, which is the real power divided by the power factor. For this alternator, the maximum apparent power is $P/\text{PF} = 35/0.7 = 50$ MVA. At unity power factor all of this would be real power, which means that the maximum real power that this alternator can supply is 50 MW.

- 15.13** An induction motor delivers 50 hp while operating at 80 percent efficiency from 480-V lines. If the power factor is 0.6, what current does the motor draw? If the power factor is 0.9, instead, what current does this motor draw?

The current can be found from $P = VI \times \text{PF}$, where P is the motor input power of $50 \times 745.7/0.8 = 46.6$ kW. For a power factor of 0.6, the current to the motor is

$$I = \frac{P}{V \times \text{PF}} = \frac{46.6 \times 10^3}{480 \times 0.6} = 162 \text{ A}$$

And, for a power factor of 0.9, it is

$$I = \frac{P}{V \times \text{PF}} = \frac{46.6 \times 10^3}{480 \times 0.9} = 108 \text{ A}$$

This 54-A decrease in current for the same output power shows why a large power factor is desirable.

- 15.14** For the circuit shown in Fig. 15-4, find the wattmeter reading when the \pm terminal of the potential coil is connected to node a , and also when it is connected to node b .

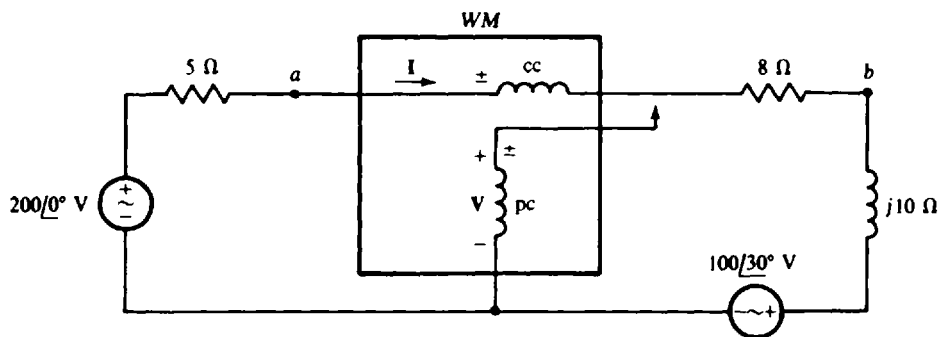

Fig. 15-4

The wattmeter reading is equal to $VI \cos \theta$, where V is the rms voltage across the potential coil, I is the rms current flowing through the current coil, and θ is the phase angle difference of the corresponding voltage and current phasors when they are referenced as shown with respect to the \pm markings of the wattmeter coils. These three quantities must be found to determine the wattmeter reading.

The phasor current I is

$$I = \frac{200\angle 0^\circ - 100\angle 30^\circ}{5 + 8 + j10} = \frac{124\angle -23.8^\circ}{16.4\angle 37.6^\circ} = 7.56\angle -61.4^\circ \text{ A}$$

With the \pm terminal of the potential coil at node a , the phasor voltage drop V across this coil is the $200\angle 0^\circ$ -V source voltage minus the drop across the 5- Ω resistor:

$$V = 200\angle 0^\circ - 5I = 200\angle 0^\circ - 5(7.56\angle -61.4^\circ) = 185\angle 10.3^\circ \text{ V}$$

The wattmeter reading is

$$P = VI \cos \theta = 185(7.56) \cos [10.3^\circ - (-61.4^\circ)] = 439 \text{ W}$$

With the \pm terminal of the potential coil at node b , V is equal to the voltage drop across the $j10\text{-}\Omega$ impedance and the $100\angle 30^\circ$ -V source:

$$V = j10(7.56\angle -61.4^\circ) + 100\angle 30^\circ = 176\angle 29.4^\circ \text{ V}$$

And so the wattmeter reading is

$$P = VI \cos \theta = 176(7.56) \cos [29.4^\circ - (-61.4^\circ)] = -18 \text{ W}$$

Probably the wattmeter cannot directly give a negative reading. If not, then the connections to one wattmeter coil should be reversed so that the wattmeter reads upscale. And, the reading should be interpreted as being negative.

15.15 In the circuit shown in Fig. 15-5, find the total power absorbed by the three resistors. Then find the sum of the readings of the two wattmeters. Compare results.

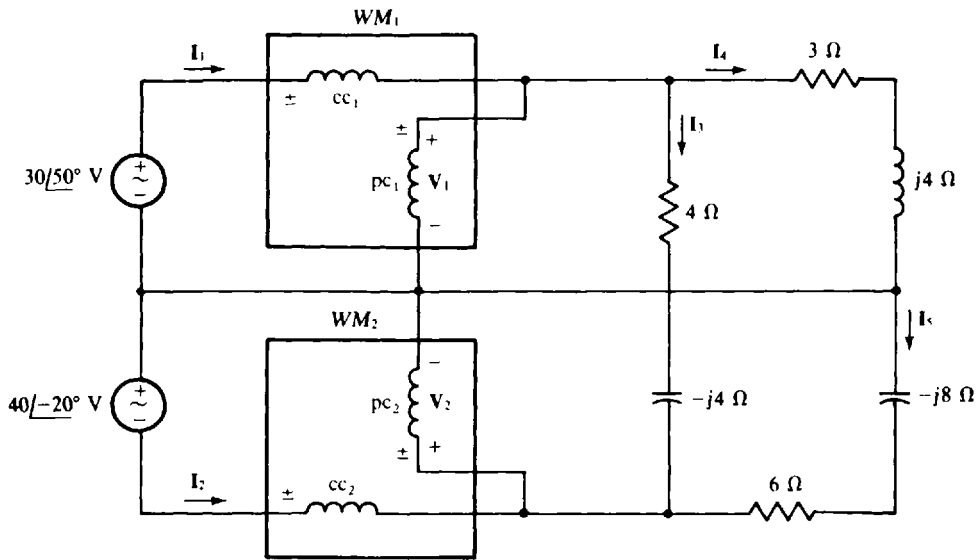

Fig. 15-5

The powers absorbed by the resistors can be found by using $P = I^2R$. The current through the resistors are

$$I_3 = \frac{30\angle 50^\circ + 40\angle -20^\circ}{4 - j4} = \frac{57.6\angle 9.29^\circ}{5.66\angle -45^\circ} = 10.19\angle 54.3^\circ \text{ A}$$

$$I_4 = \frac{30\angle 50^\circ}{3 + j4} = 6\angle -3.13^\circ \text{ A} \quad \text{and} \quad I_5 = \frac{40\angle -20^\circ}{6 - j8} = 4\angle 33.1^\circ \text{ A}$$

Of course, only the rms values of these currents are used in $P = I^2R$:

$$P_T = I_3^2(4) + I_4^2(3) + I_5^2(6) = 10.19^2(4) + 6^2(3) + 4^2(6) = 619 \text{ W}$$

The currents I_1 and I_2 are needed in finding the wattmeter readings since these are the currents that flow through the current coils:

$$I_1 = I_3 + I_4 = 10.19\angle 54.3^\circ + 6\angle -3.13^\circ = 14.34\angle 33.6^\circ \text{ A}$$

$$I_2 = -I_3 - I_5 = -10.19\angle 54.3^\circ - 4\angle 33.1^\circ = 14\angle -131.6^\circ \text{ A}$$

Obviously, the potential coil voltages are $V_1 = 30/\underline{50}$ V and $V_2 = -40/\underline{-20} = 40/\underline{160}$ V. These potential coil voltages and current coil currents produce wattmeter readings that have a sum of

$$P_T = 30(14.34) \cos(50^\circ - 33.6^\circ) + 40(14) \cos[160^\circ - (-131.6^\circ)] = 413 + 206 = 619 \text{ W}$$

Observe that this sum of the two wattmeter readings is equal to the total power absorbed. This should not be expected, since each wattmeter reading cannot be associated with powers absorbed by certain resistors. It can be shown, though, that this result is completely general for loads with three wires and for the connections shown. This use of wattmeters is the famous *two-wattmeter method* that is popular for measuring power to three-phase loads, as will be considered in Chap. 17.

- 15.16** What is the reactive factor of an inductive load that has an apparent power input of 50 kVA while absorbing 30 kW?

The reactive factor is the sine of the power factor angle θ , which is

$$\theta = \cos^{-1} \frac{P}{S} = \cos^{-1} \frac{30\,000}{50\,000} = 53.1$$

So

$$\text{RF} = \sin 53.1 = 0.8$$

- 15.17** With $v = 200 \sin(377t + 30^\circ)$ V applied, a circuit draws $i = 25 \sin(377t - 20^\circ)$ A. What is the reactive factor and what is the reactive power absorbed?

The reactive factor is the sine of the power factor angle θ , which is the phase angle of the voltage minus the phase angle of the current: $\theta = 30^\circ - (-20^\circ) = 50^\circ$. So, $\text{RF} = \sin 50^\circ = 0.766$. The reactive power absorbed can be found from $Q = VI \times \text{RF}$, where V and I are the rms values of the voltage and current:

$$Q = \frac{200}{\sqrt{2}} \times \frac{25}{\sqrt{2}} \times 0.766 = 1.92 \times 10^3 = 1.92 \text{ kVAR}$$

- 15.18** What is the reactive factor of a circuit that has an input impedance of $40/\underline{50}$ Ω ? Also, what reactive power does the circuit absorb when the input current is 5 A?

The reactive factor is the sine of the impedance angle: $\text{RF} = \sin 50^\circ = 0.766$. An easy way to find the reactive power is with the formula $Q = I^2 X$, where X , the reactance, is equal to $40 \sin 50^\circ = 30.64 \Omega$:

$$Q = I^2 X = 5^2(30.64) = 766 \text{ VAR}$$

- 15.19** What is the reactive factor of a circuit that has an input impedance of $20/\underline{-40}$ Ω ? What is the reactive power absorbed with 240 V applied?

The reactive factor is the sine of the impedance angle: $\text{RF} = \sin(-40^\circ) = -0.643$. Perhaps the easiest way to find the reactive power absorbed is from $Q = VI \times \text{RF}$. The only unknown in this formula is the rms current, which is equal to the rms voltage divided by the magnitude of impedance: $I = V/Z = 240/20 = 12$ A. Then,

$$Q = VI \times \text{RF} = 240(12)(-0.643) = -1.85 \text{ kVAR}$$

The negative sign indicates that the circuit delivers vars, as should be expected from this capacitive circuit.

As a check, the formula $Q = I^2 X$ can be used, in which X , the imaginary part of the impedance, is $X = 20 \sin(-40^\circ) = -12.86 \Omega$: $Q = 12^2(-12.86) = -1.85 \text{ kVAR}$, the same.

- 15.20** When 3 A flows through a circuit with an input admittance of $0.4 + j0.5$ S, what reactive power does the circuit consume?

The reactive power consumed can be found from $Q = I^2 X$ after X is found from the admittance. Of course X is the imaginary part of the input impedance Z . Solving for Z ,

$$Z = \frac{1}{Y} = \frac{1}{0.4 + j0.5} = \frac{1}{0.64 \angle 51.3} = 1.56 \angle -51.3 = 0.976 - j1.22 \Omega$$

So, $X = -1.22 \Omega$, and

$$Q = I^2 X = 3^2(-1.22) = -11 \text{ VAR}$$

The negative sign indicates that the circuit delivers reactive power.

A check can be made by using $Q = -V^2 B$, where $V = IZ = 3(1.56) = 4.68 \text{ V}$. (Of course, $B = 0.5 \text{ S}$ from the input admittance.) So,

$$Q = -V^2 B = -(4.68)^2(0.5) = -11 \text{ VAR}$$

- 15.21** Two circuit elements in series consume 60 VAR when connected to a 120-V, 60-Hz source. If the reactive factor is 0.6, what are the two components and what are their values?

The two components can be found from the input impedance. The angle of this impedance is the arcsine of the reactive factor: $\theta = \sin^{-1} 0.6 = 36.9^\circ$. The magnitude of the impedance can be found by substituting $I = V/Z$ into $Q = VI \times \text{RF}$:

$$Q = V \left(\frac{V}{Z} \right) (\text{RF}) \quad \text{from which} \quad Z = \frac{V^2 (\text{RF})}{Q} = \frac{120^2 (0.6)}{60} = 144 \Omega$$

So

$$Z = 144 \angle 36.9 = 115 + j86.4 \Omega$$

From this impedance, the two elements must be a resistor with a resistance of $R = 115 \Omega$ and an inductor with a reactance of 86.4Ω . The inductance is

$$L = \frac{X}{\omega} = \frac{86.4}{2\pi(60)} = 0.229 \text{ H}$$

- 15.22** What resistor and capacitor in parallel present the same load to a 480-V, 60-Hz source as a fully loaded 20-hp synchronous motor that operates at a 75 percent efficiency and a 0.8 leading power factor?

The resistance can be found from the motor input power, which is

$$P_{\text{in}} = \frac{P_{\text{out}}}{\eta} = \frac{20 \times 745.7}{0.75} = 19.9 \text{ kW}$$

From $P_{\text{in}} = V^2 R$,

$$R = \frac{V^2}{P_{\text{in}}} = \frac{480^2}{19.9 \times 10^3} = 11.6 \Omega$$

The corresponding conductance and the admittance angle, which is the negative of the power factor angle, can be used to find the capacitive susceptance. And then the capacitance can be found from this susceptance. The conductance is $G = 1/11.6 = 0.0863 \text{ S}$, and the admittance angle is $\phi = \cos^{-1} 0.8 = 36.9^\circ$. So, the susceptance is

$$B = G \tan \phi = 0.0863 \tan 36.9^\circ = 0.0647 \text{ S}$$

Finally, the capacitance is this susceptance divided by the radian frequency:

$$C = \frac{B}{\omega} = \frac{0.0647}{2\pi(60)} = 172 \mu\text{F}$$

- 15.23** A 120-mH inductor is energized by 120 V at 60 Hz. Find the average, peak, and reactive powers absorbed.

Since the power factor is zero ($\text{PF} = \cos 90^\circ = 0$), the inductor absorbs zero average power: $P = 0$ W. The peak power can be obtained from the instantaneous power. As derived in this chapter, the general expression for instantaneous power is

$$p = VI \cos \theta - VI \cos(2\omega t + \theta)$$

For an inductor, $\theta = 90^\circ$, which means that the first term is zero. Consequently, the peak power is the peak value of the second term, which is $-VI$: $p_{\max} = VI$. The voltage V is given: $V = 120$ V. The current I can be found from this voltage divided by the inductive reactance:

$$I = \frac{V}{X} = \frac{120}{2\pi(60)(120 \times 10^{-3})} = \frac{120}{45.24} = 2.65 \text{ A}$$

So
$$p_{\max} = VI = 120(2.65) = 318 \text{ W}$$

The reactive power absorbed is

$$Q = I^2 X = 2.65^2(45.24) = 318 \text{ VAR}$$

which has the same numerical value as the peak power absorbed by the inductor. This is generally true because $Q = I^2 X = (IX)I = VI$, and VI is the peak power absorbed by the inductor.

- 15.24** What are the power components resulting from a 4-A current flowing into a load of $30/40 \Omega$? In other words, what are the complex, real, reactive, and apparent powers of the load?

From Fig. 15-3*b*, the complex power \mathbf{S} is

$$\mathbf{S} = I^2 \mathbf{Z} = 4^2(30/40) = 480/40 = 368 + j309 \text{ VA}$$

The real power is the real part, $P = 368$ W, the reactive power is the imaginary part, $Q = 309$ VAR, and the apparent power is the magnitude, $S = 480$ VA.

- 15.25** Find the power components of an induction motor that delivers 5 hp while operating at an 85 percent efficiency and a 0.8 lagging power factor.

The input power is

$$P_{\text{in}} = \frac{P_{\text{out}}}{\eta} = \frac{5 \times 745.7}{0.85} \text{ W} = 4.386 \text{ kW}$$

The apparent power, which is the magnitude of the complex power, is the real power divided by the power factor: $S = 4.386/0.8 = 5.48$ kVA. The angle of the complex power is the power factor angle: $\theta = \cos^{-1} 0.8 = 36.9^\circ$. So, the complex power is

$$\mathbf{S} = 5.48/36.9^\circ = 4.386 + j3.29 \text{ kVA}$$

The reactive power is, of course, the imaginary part: $Q = 3.29$ kVAR.

- 15.26** Find the power components of a load that draws $20/-30^\circ$ A with $240/20^\circ$ V applied.

The complex power can be found from $\mathbf{S} = \mathbf{V}\mathbf{I}^*$. Since $\mathbf{I} = 20/-30^\circ$ A, its conjugate is $\mathbf{I}^* = 20/30^\circ$ A, and the complex power is

$$\mathbf{S} = (240/20^\circ)(20/30^\circ) = 4800/50^\circ \text{ VA} = 3.09 + j3.68 \text{ kVA}$$

From the magnitude and real and imaginary parts, the apparent, real, and reactive powers are $S = 4.8$ kVA, $P = 3.09$ kW, and $Q = 3.68$ kVAR.

- 15.27** A load, connected across a 12 470-V line, draws 20 A at a 0.75 lagging power factor. Find the load impedance and the power components.

Since the impedance magnitude is equal to the voltage divided by the current, and the impedance angle is the power factor angle, the load impedance is

$$\mathbf{Z} = \frac{12\,470}{20} \angle \cos^{-1} 0.75 = 623.5 \angle 41.4^\circ \Omega$$

From $\mathbf{S} = I^2 \mathbf{Z}$, the complex power is

$$\mathbf{S} = 20^2(623.5 \angle 41.4^\circ) = 249.4 \times 10^3 \angle 41.4^\circ \text{ VA} = 187 + j165 \text{ kVA}$$

From the magnitude and the real and imaginary parts, $S = 249.4 \text{ kVA}$, $P = 187 \text{ kW}$, and $Q = 165 \text{ kVAR}$.

15.28 A 20- μF capacitor and a parallel 200- Ω resistor draw 4 A at 60 Hz. Find the power components.

Once the impedance is found, the complex power can be obtained from $\mathbf{S} = I^2 \mathbf{Z}$. The capacitive reactance is

$$X = -\frac{1}{\omega C} = \frac{-1}{2\pi(60)(20 \times 10^{-6})} = -132.6 \Omega$$

and the impedance of the parallel combination is

$$\mathbf{Z} = \frac{200(-j132.6)}{200 - j132.6} = 110.5 \angle -56.4^\circ \Omega$$

Substitution into $\mathbf{S} = I^2 \mathbf{Z}$ results in a complex power of

$$\mathbf{S} = 4^2(110.5 \angle -56.4^\circ) = 1.77 \times 10^3 \angle -56.4^\circ \text{ VA} = 0.98 - j1.47 \text{ kVA}$$

So, $S = 1.77 \text{ kVA}$, $P = 0.98 \text{ kW}$, and $Q = -1.47 \text{ kVAR}$.

15.29 A fully loaded 10-hp induction motor operates from a 480-V, 60-Hz line at an efficiency of 85 percent and a 0.8 lagging power factor. Find the overall power factor when a 33.3- μF capacitor is placed in parallel with the motor.

The power factor can be determined from the power factor angle, which is $\theta = \tan^{-1}(Q_T/P_{in})$. For this, the input power P_{in} and the total reactive power Q_T are needed. The capacitor does not change the real power absorbed, which is

$$P_{in} = \frac{P_{out}}{\eta} = \frac{10 \times 745.7}{0.85} = 8.77 \text{ kW}$$

The total reactive power is the sum of the motor and capacitive reactive powers. As is evident from power triangle considerations, the reactive power Q_M of the motor is equal to the power times the tangent of the motor power factor angle, which is the arccosine of the motor power factor:

$$Q_M = P_{in} \tan \theta_M = 8.77 \tan(\cos^{-1} 0.8) = 6.58 \text{ kVAR}$$

The reactive power absorbed by the capacitor is

$$Q_C = -\omega C V^2 = -2\pi(60)(33.3 \times 10^{-6})(480)^2 = -2.89 \text{ kVAR}$$

And the total reactive power is

$$Q_T = Q_M + Q_C = 6.58 - 2.89 = 3.69 \text{ kVAR}$$

With Q_T and P_{in} known, the power factor angle θ can be determined:

$$\theta = \tan^{-1} \frac{Q_T}{P_{in}} = \tan^{-1} \frac{3.69 \times 10^3}{8.77 \times 10^3} = 22.8^\circ$$

And the overall power factor is $\text{PF} = \cos 22.8^\circ = 0.922$. It is lagging because the power factor angle is positive.

- 15.30** A 240-V source energizes the parallel combination of a purely resistive 6-kW heater and an induction motor that draws 7 kVA at a 0.8 lagging power factor. Find the overall load power factor and also the current from the source.

The power factor and current can be determined from the total complex power S_T , which is the sum of the complex powers of the heater and motor:

$$S_T = S_H + S_M = 6000\angle 0 + 7000\angle \cos^{-1} 0.8 = 6000\angle 0 + 7000\angle 36.9 = 12.34\angle 19.9 \text{ kVA}$$

The overall power factor is the cosine of the angle of the total complex power: $\text{PF} = \cos 19.9 = 0.94$. It is lagging, of course, because the power factor angle is positive. The source current is equal to the total apparent power divided by the voltage:

$$I = \frac{12.34 \times 10^3}{240} = 51.4 \text{ A}$$

Notice that the total apparent power of 12.34 kVA is not the sum of the load apparent powers of 6 and 7 kVA. This is generally true except in the unusual situation in which all complex powers have the same angle.

- 15.31** A 480-V source energizes two loads in parallel, supplying 2 kVA at a 0.5 lagging power factor to one load and 4 kVA at a 0.6 leading power factor to the other load. Find the source current and also the total impedance of the combination.

The current can be found from the total apparent power, which is the magnitude of the total complex power:

$$S = 2000\angle \cos^{-1} 0.5 + 4000\angle -\cos^{-1} 0.6 = 2000\angle 60 + 4000\angle -53.13 = 3.703\angle -23.4 \text{ kVA}$$

The power factor angle for the 4-kVA load is negative because the power factor is leading, which means that the current leads the voltage.

The current is equal to the apparent power divided by the voltage:

$$I = \frac{S}{V} = \frac{3.703 \times 10^3}{480} = 7.715 \text{ A}$$

From $S = I^2 Z$, the impedance is equal to the complex power divided by the square of the current:

$$Z = \frac{S}{I^2} = \frac{3.703 \times 10^3 \angle -23.4}{7.715^2} = 62.2 \angle -23.4 \Omega$$

- 15.32** Three loads are connected across a 277-V line. One is a fully loaded 5-hp induction motor operating at a 75 percent efficiency and a 0.7 lagging power factor. Another is a fully loaded 7-hp synchronous motor operating at an 80 percent efficiency and a 0.4 leading power factor. The third is a 5-kW resistive heater. Find the total line current and the overall power factor.

The line current and power factor can be determined from the total complex power, which is the sum of the individual complex powers. The complex power of the induction motor has a magnitude that is equal to the input power divided by the power factor, and an angle that is the power factor angle. The same is true for the synchronous motor. The complex power for the heater is, of course, the same as the real power. So,

$$\begin{aligned} S &= \frac{5 \times 745.7}{0.75 \times 0.7} \angle \cos^{-1} 0.7 + \frac{7 \times 745.7}{0.8 \times 0.4} \angle -\cos^{-1} 0.4 + 5000\angle 0 \\ &= 7.1 \times 10^3 \angle 45.6 + 16.3 \times 10^3 \angle -66.4 + 5000\angle 0 = 19.23 \angle -30.9 \text{ kVA} \end{aligned}$$

The total line current is equal to the apparent power divided by the line voltage: $I = (19.23 \times 10^3) / 277 = 69.4 \text{ A}$. And, the overall power factor is the cosine of the angle of the total complex power: $\text{PF} = \cos(-30.9) = 0.858$. It is leading because the power factor angle is negative.

- 15.33** In the circuit shown in Fig. 15-6, load 1 absorbs 2.4 kW and 1.8 kVAR, load 2 absorbs 1.3 kW and 2.6 kVAR, and load 3 absorbs 1 kW and generates 1.2 kVAR. Find the total power components, the source current I_1 , and the impedance of each load.

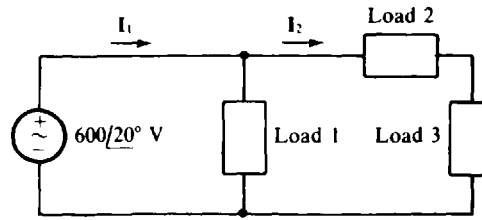

Fig. 15-6

The total complex power is the sum of the individual complex powers:

$$\begin{aligned} S_T &= S_1 + S_2 + S_3 = (2400 + j1800) + (1300 + j2600) + (1000 - j1200) \\ &= 4700 + j3200 \text{ VA} = 5.69/34.2 \text{ kVA} \end{aligned}$$

From the total complex power, the total apparent power is $S_T = 5.69 \text{ kVA}$, the total real power is $P_T = 4.7 \text{ kW}$, and the total reactive power is $Q_T = 3.2 \text{ kVAR}$. The source current magnitude I_1 is equal to the apparent power divided by the source voltage: $I_1 = (5.69 \times 10^3)/600 = 9.48 \text{ A}$. And the angle of I_1 is the angle of the voltage minus the power factor angle: $20 - 34.2 = -14.2$. So, $I_1 = 9.48/-14.2 \text{ A}$.

The angle of the load 1 impedance Z_1 is the load power factor angle, which is also the angle of the complex power S_1 . Since $S_1 = 2400 + j1800 = 3000/36.9 \text{ VA}$, this impedance angle is $\theta = 36.9$. Because the load 1 voltage is known, the magnitude Z_1 can be found from $S_1 = V^2/Z_1$:

$$Z_1 = \frac{V^2}{S_1} = \frac{600^2}{3000} = 120 \Omega$$

So, $Z_1 = Z_1/\theta = 120/36.9 \Omega$. The impedances Z_2 and Z_3 of loads 2 and 3 cannot be found in a similar manner because the load voltages are not known. But the rms current I_2 can be found from the sum of the complex powers of loads 2 and 3, and used in $S = I^2 Z$ to find the impedances. This sum is

$$S_{2,3} = (1300 + j2600) + (1000 - j1200) = 2300 + j1400 = 2.693/31.3 \text{ kVA}$$

The apparent power $S_{2,3}$ can be used to obtain I_2 from $S_{2,3} = VI_2$:

$$I_2 = \frac{S_{2,3}}{V} = \frac{2.693 \times 10^3}{600} = 4.49 \text{ A}$$

Since $S_2 = 1300 + j2600 \text{ VA} = 2.91/63.4 \text{ kVA}$, the impedance of load 2 is

$$Z_2 = \frac{S_2}{I_2^2} = \frac{2.91 \times 10^3/63.4}{4.49^2} = 144/63.4 \Omega$$

Similarly, $S_3 = 1000 - j1200 \text{ VA} = 1.562/-50.2 \text{ kVA}$, and

$$Z_3 = \frac{S_3}{I_2^2} = \frac{1.562 \times 10^3/-50.2}{4.49^2} = 77.6/-50.2 \Omega$$

- 15.34** A load that absorbs 100-kW at a 0.7 lagging power factor has capacitors placed across it to produce an overall power factor of 0.9 lagging. The line voltage is 480 V. How much reactive power must the capacitors produce, and what is the resulting decrease in line current?

The initial reactive power is $Q_i = P \tan \theta_i$, where θ_i is the initial power factor angle: $\theta_i = \cos^{-1} 0.7 = 45.6$. Therefore

$$Q_i = 100 \times 10^3 \tan 45.6 = 102 \text{ kVAR}$$

The final reactive power is

$$Q_f = P \tan \theta_f = 100 \times 10^3 \tan (\cos^{-1} 0.9) = 48.4 \text{ kVAR}$$

Consequently, the capacitors must supply $102.4 - 48.4 = 53.6 \text{ kVAR}$.

The initial and final currents can be obtained from $P = VI \times \text{PF}$:

$$I_i = \frac{P}{V \times \text{PF}_i} = \frac{100 \times 10^3}{480 \times 0.7} = 297.6 \text{ A} \quad \text{and} \quad I_f = \frac{P}{V \times \text{PF}_f} = \frac{100 \times 10^3}{480 \times 0.9} = 231.5 \text{ A}$$

The resulting decrease in line current is $297.6 - 231.5 = 66.1 \text{ A}$.

- 15.35** A synchronous motor that draws 20 kW is in parallel with an induction motor that draws 50 kW at a lagging power factor of 0.7. If the synchronous motor is operated at a leading power factor, how much reactive power must it provide to cause the overall power factor to be 0.9 lagging, and what is its power factor?

Since the total power input is $P_T = 20 + 50 = 70 \text{ kW}$, the total reactive power is

$$Q_T = P_T \tan (\cos^{-1} \text{PF}_T) = 70 \tan (\cos^{-1} 0.9) = 33.9 \text{ kVAR}$$

Because the reactive power absorbed by the induction motor is

$$Q_{\text{IM}} = P_{\text{IM}} \tan \theta_{\text{IM}} = 50 \tan (\cos^{-1} 0.7) = 51 \text{ kVAR}$$

the synchronous motor must supply $Q_{\text{SM}} = Q_T = 51 - 33.9 = 17.1 \text{ kVAR}$. Thus, $Q_{\text{SM}} = -17.1 \text{ kVAR}$.

The resulting power factor of the synchronous motor is $\cos \theta_{\text{SM}}$ in which θ_{SM} , the synchronous motor power factor angle, is

$$\theta_{\text{SM}} = \tan^{-1} \frac{Q_{\text{SM}}}{P_{\text{SM}}} = \tan^{-1} \frac{-17.1 \times 10^3}{20 \times 10^3} = -40.5$$

So, $\text{PF}_{\text{SM}} = \cos (-40.5) = 0.76$ leading.

- 15.36** A factory draws 100 A at a 0.7 lagging power factor from a 12 470-V, 60-Hz line. What capacitor placed across the line at the input to the factory increases the overall power factor to unity? Also, what are the final currents for the factory, capacitor, and line?

The capacitance can be determined from the reactive power that the capacitor must provide to cause the power factor to be unity. The reactive power absorbed by the factory is the apparent power times the reactive factor, which is the sine of the arccosine of the power factor: $\text{RF} = \sin (\cos^{-1} 0.7) = 0.714$. Thus

$$Q = VI \times \text{RF} = 12\,470 \times 100 \times 0.714 = 890.5 \text{ kVAR}$$

For a unity power factor, the capacitor must supply all this reactive power. Since the formula for generated capacitor reactive power is $Q = \omega C V^2$, the required capacitance is

$$C = \frac{Q}{\omega V^2} = \frac{890.5 \times 10^3}{2\pi(60)(12\,470)^2} = 15.2 \mu\text{F}$$

Adding the capacitor in parallel does not change the current input to the factory since there is no change in the factory load. This current remains at 100 A. The current to the capacitor can be found from $Q = VI_c \times \text{RF}$ with $\text{RF} = -1$ since the power factor angle is -90° for the capacitor. The result is

$$I_c = \frac{Q}{V \times \text{RF}} = \frac{-890.5 \times 10^3}{(12\,470)(-1)} = 71.4 \text{ A}$$

The total final line current I_{fL} can be found from the input power, which is

$$P = VI_{fL} \times \text{PF}_i = (12\,470)(100)(0.7) = 873 \text{ kW}$$

Adding the capacitor does not change this power, but it does change the power factor to 1. So, from $P = VI_{fL} \times PF_f$,

$$873 \times 10^3 = 12\,470(I_{fL})(1) \quad \text{from which} \quad I_{fL} = \frac{873 \times 10^3}{12\,470} = 70 \text{ A}$$

Notice that the 70-A rms final line current is not equal to the sum of the capacitor 71.4-A rms current and the factory 100-A rms current. This should not be surprising because, in general, rms quantities cannot be validly added since the phasor angles are not included.

15.37 A 240-V, 60-Hz source energizes a load of $30\angle 50^\circ \Omega$. What capacitor in parallel with this load produces an overall power factor of 0.95 lagging?

Although powers could be used in the solution, it is often easier to use admittance when a circuit or its impedance is specified. The initial admittance is

$$Y = \frac{1}{30\angle 50^\circ} = 33.3 \times 10^{-3} \angle -50^\circ = 21.4 - j25.5 \text{ mS}$$

Adding the capacitor changes only the susceptance, which becomes

$$B = G \tan(-\theta) = 21.4 \tan(-\cos^{-1} 0.95) = -7.04 \text{ mS}$$

This formula $B = G \tan(-\theta)$ should be evident from admittance triangle considerations and the fact that the admittance angle is the negative of the power factor angle. From $\Delta B = \omega C$,

$$C = \frac{\Delta B}{\omega} = \frac{25.5 \times 10^{-3} - 7.04 \times 10^{-3}}{2\pi(60)} = 49.1 \times 10^{-6} = 49.1 \mu\text{F}$$

15.38 At 60 Hz, what is the power factor of the circuit shown in Fig. 15-7? What capacitor connected across the input terminals causes the overall power factor to be 1 (unity)? What capacitor causes the overall power factor to be 0.85 lagging?

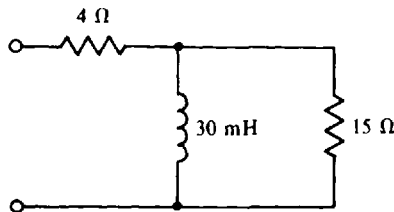

Fig. 15-7

Because a circuit is specified, the power factor and capacitor are probably easier to find using impedance and admittance instead of powers. The power factor is the cosine of the impedance angle. Since the reactance of the inductor is $2\pi(60)(0.03) = 11.3 \Omega$, the impedance of the circuit is

$$Z = 4 + \frac{15(j11.3)}{15 + j11.3} = 11.9\angle 37.38^\circ \Omega$$

And the power factor is $PF = \cos 37.38^\circ = 0.795$ lagging.

Because the capacitor is to be connected in parallel, the circuit admittance should be used to determine the capacitance. Before the capacitor is added, this admittance is

$$Y = \frac{1}{Z} = \frac{1}{11.9\angle 37.38^\circ} = 0.0842\angle -37.38^\circ = 66.9 - j51.1 \text{ mS}$$

For unity power factor, the imaginary part of the admittance must be zero, which means that the added capacitor must have a susceptance of 51.1 mS. Consequently, its capacitance is

$$C = \frac{B}{\omega} = \frac{51.1 \times 10^{-3}}{2\pi(60)} = 136 \times 10^{-6} = 136 \mu\text{F}$$

A different capacitor is required for a power factor of 0.85 lagging. The new susceptance can be found from $B = G \tan(-\theta)$ where G is the conductance, which does not change by adding a parallel capacitor, and θ is the new power factor angle:

$$B = 66.9 \tan(-\cos^{-1} 0.85) = -41.5 \text{ mS}$$

Because the added capacitor provides the change in susceptance, its capacitance is

$$C = \frac{\Delta B}{\omega} = \frac{51.1 \times 10^{-3} - 41.5 \times 10^{-3}}{2\pi(60)} = 25.6 \times 10^{-6} = 25.6 \mu\text{F}$$

Naturally, less capacitance is required to improve the power factor to 0.85 lagging than to 1.

- 15.39** An induction motor draws 50 kW at a 0.6 lagging power factor from a 480-V, 60-Hz source. What parallel capacitor will increase the overall power factor to 0.9 lagging? What is the resulting decrease in input current?

The pertinent capacitance formula is

$$C = \frac{P[\tan(\cos^{-1} \text{PF}_i) - \tan(\cos^{-1} \text{PF}_f)]}{\omega V^2}$$

So, here,

$$C = \frac{50\,000[\tan(\cos^{-1} 0.6) - \tan(\cos^{-1} 0.9)]}{2\pi(60)(480)^2} = 489 \mu\text{F}$$

From $P = VI \times \text{PF}$, the decrease in input current is

$$\Delta I = I_i - I_f = \frac{P}{V \times \text{PF}_i} - \frac{P}{V \times \text{PF}_f} = \frac{50\,000}{480(0.6)} - \frac{50\,000}{480(0.9)} = 57.9 \text{ A}$$

- 15.40** A factory draws 30 MVA at a 0.7 lagging power factor from a 12 470-V, 60-Hz line. Find the capacitance of the parallel capacitors required to improve the power factor to 0.85 lagging. Also, find the resulting decrease in line current.

The power absorbed by the factor is $P = 30(0.7) = 21 \text{ MW}$. So, from the capacitance formula specified in Prob. 15.39, the capacitance required is

$$C = \frac{(21 \times 10^6)[\tan(\cos^{-1} 0.7) - \tan(\cos^{-1} 0.85)]}{2\pi(60)(12\,470)^2} = 143 \mu\text{F}$$

The decrease in line current is equal to the decrease in apparent power divided by the line voltage. The initial apparent power is the specified 30 MVA, and the final apparent power is $P/\text{PF}_f = 21 \times 10^6/0.85 = 24.7 \times 10^6 \text{ VA}$. So,

$$\Delta I = \frac{30 \times 10^6 - 24.7 \times 10^6}{12\,470} = 425 \text{ A}$$

- 15.41** A 20-MW industrial load supplied from a 12 470-V, 60-Hz line has its power factor improved to 0.9 lagging by the addition of a 230- μF bank of capacitors. Find the power factor of the original load.

The initial reactive power is needed. It is equal to the final reactive power plus that added by the capacitors:

$$\begin{aligned} Q_i &= P \tan \theta_f + \omega CV^2 = 20 \times 10^6 \tan (\cos^{-1} 0.9) + 2\pi(60)(230 \times 10^{-6})(12470)^2 \\ &= 9.69 \times 10^6 + 13.5 \times 10^6 = 23.2 \text{ MVAR} \end{aligned}$$

The real power and the initial reactive power can be used to find the initial power factor angle:

$$\theta_i = \tan^{-1} \frac{Q_i}{P} = \tan^{-1} \frac{23.2 \times 10^6}{20 \times 10^6} = 49.2$$

Finally, the initial power factor is $\text{PF}_i = \cos \theta_i = \cos 49.2 = 0.653$ lagging.

- 15.42** A 480-V, 60-Hz source energizes a load consisting of an induction motor and a synchronous motor. The induction motor draws 50 kW at a 0.65 lagging power factor, and the synchronous motor draws 10 kW at a 0.6 leading power factor. Find the capacitance of the parallel capacitor required to produce an overall power factor of 0.9 lagging.

The required change in reactive power is needed. The initial absorbed reactive power is the sum of that of the two motors, which from $Q = P \tan \theta$ is

$$Q_i = 50 \tan (\cos^{-1} 0.65) + 10 \tan (-\cos^{-1} 0.6) = 58.456 - 13.333 = 45.12 \text{ kVAR}$$

The final reactive power is, from $Q_f = P_T \tan (\cos^{-1} \text{PF}_f)$,

$$Q_f = (50 + 10) \tan (\cos^{-1} 0.9) = 29.06 \text{ kVAR}$$

So the change ΔQ in reactive power is $\Delta Q = 45.12 - 29.06 = 16.1 \text{ kVAR}$ and

$$C = \frac{\Delta Q}{\omega V^2} = \frac{16.1 \times 10^3}{2\pi(60)(480)^2} = 185 \mu\text{F}$$

Supplementary Problems

- 15.43** The instantaneous power absorbed by a circuit is $p = 6 + 4 \cos^2(2t + 30^\circ) \text{ W}$. Find the maximum, minimum, and average powers absorbed.
Ans. $p_{\max} = 10 \text{ W}$, $p_{\min} = 6 \text{ W}$, $P = 8 \text{ W}$
- 15.44** With $170 \sin(377t + 10^\circ) \text{ V}$ applied, a circuit draws $8 \sin(377t + 35^\circ) \text{ A}$. Find the power factor and the maximum, minimum, and average powers absorbed.
Ans. $\text{PF} = 0.906$ leading, $p_{\max} = 1.3 \text{ kW}$, $p_{\min} = -63.7 \text{ W}$, $P = 616 \text{ W}$
- 15.45** For each following load voltage and current pair, find the corresponding power factor and average power absorbed:
- (a) $v = 170 \sin(50t - 40^\circ) \text{ V}$, $i = 4.3 \sin(50t + 10^\circ) \text{ A}$
 (b) $v = 340 \cos(377t - 50^\circ) \text{ V}$, $i = 6.1 \sin(377t + 30^\circ) \text{ A}$
 (c) $v = 679 \sin(377t + 40^\circ) \text{ V}$, $i = -7.2 \cos(377t + 50^\circ) \text{ A}$
Ans. (a) 0.643 leading, 235 W; (b) 0.985 lagging, 1.02 kW; (c) 0.174 lagging, 424 W
- 15.46** Find the power factor of a fully loaded 5-hp induction motor that operates at 85 percent efficiency while drawing 15 A from a 480-V line.
Ans. 0.609 lagging

- 15.47** What is the power factor of a circuit that has an input impedance of $5/\underline{-25^\circ} \Omega$? Also, what is the power absorbed when 50 V is applied?
Ans. 0.906 leading, 453 W
- 15.48** If a circuit has an input admittance of $40 + j20 \text{ S}$ and an applied voltage of 180 V, what is the power factor and the power absorbed?
Ans. 0.894 leading, 1.3 MW
- 15.49** A resistor in parallel with an inductor absorbs 25 W when the combination is connected to a 120-V, 60-Hz source. If the total current is 0.3 A, what are the resistance and inductance?
Ans. 576 Ω , 1.47 H
- 15.50** A coil absorbs 20 W when connected to a 240-V, 400-Hz source. If the current is 0.2 A, find the resistance and inductance of the coil.
Ans. 500 Ω , 0.434 H
- 15.51** A resistor and series capacitor draw 1 A from a 120-V, 60-Hz source at a 0.6 leading power factor. Find the resistance and capacitance.
Ans. 72 Ω , 27.6 μF
- 15.52** A resistor and parallel capacitor draw 0.6 A from a 120-V, 400-Hz source at a 0.7 leading power factor. Find the resistance and capacitance.
Ans. 286 Ω , 1.42 μF
- 15.53** A 100-kW load operates at a 0.6 lagging power factor from a 480-V, 60-Hz line. What current does the load draw? What current does the load draw if it operates at unity power factor instead?
Ans. 347 A, 208 A
- 15.54** A fully loaded 100-hp induction motor operates at 85 percent efficiency from a 480-V line. If the power factor is 0.65 lagging, what current does the motor draw? If the power factor is 0.9 lagging, instead, what current does this motor draw?
Ans. 281 A, 203 A
- 15.55** Find the wattmeter reading for the circuit shown in Fig. 15-8.
Ans. 16 W

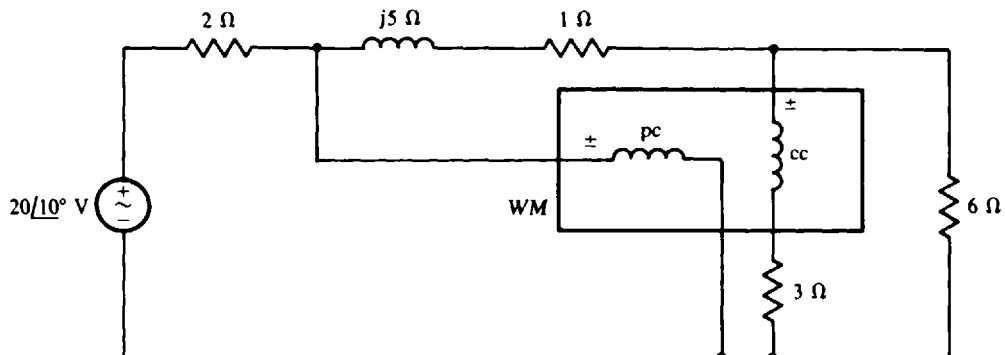

Fig. 15-8

15.56 Find each wattmeter reading for the circuit shown in Fig. 15-9.

Ans. $WM_1 = 1.54 \text{ kW}$, $WM_2 = 656 \text{ W}$

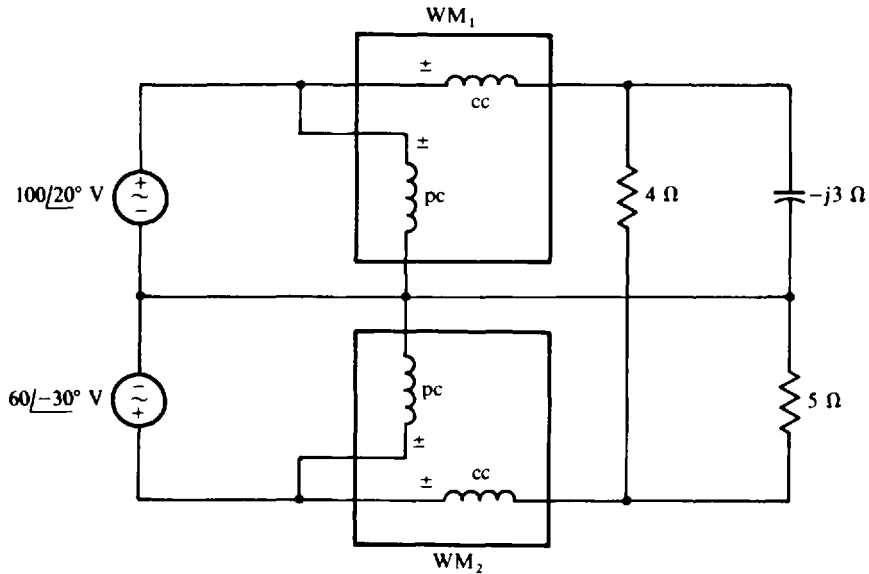

Fig. 15-9

15.57 With $200 \sin(754t + 35^\circ) \text{ V}$ applied, a circuit draws $456 \sin(754t + 15^\circ) \text{ mA}$. What is the reactive factor, and what is the reactive power absorbed?

Ans. 0.342, 15.6 VAR

15.58 With $300 \cos(377t - 75^\circ) \text{ V}$ applied, a circuit draws $2.1 \sin(377t + 70^\circ) \text{ A}$. What is the reactive factor, and what is the reactive power absorbed?

Ans. -0.819, -258 VAR

15.59 What is the reactive factor of a circuit that has an input impedance of $50\angle 35^\circ \Omega$? What reactive power does the circuit absorb when the input current is 4 A?

Ans. 0.574, 459 VAR

15.60 What is the reactive factor of a circuit that has an input impedance of $600\angle -30^\circ \Omega$? What is the reactive power absorbed when 480 V is applied?

Ans. -0.5, -192 VAR

15.61 When 120 V is applied across a circuit with an input admittance of $1.23\angle 40^\circ \text{ S}$, what reactive power does the circuit absorb?

Ans. -11.4 kVAR

15.62 When 4.1 A flows into a circuit with an input admittance of $0.7 - j1.1 \text{ S}$, what reactive power does the circuit absorb?

Ans. 10.9 VAR

- 15.63** A load consumes 500 VAR when energized from a 240-V source. If the reactive factor is 0.35, what current does the load draw and what is the load impedance?
Ans. 5.95 A, $40.3/\underline{20.5} \ \Omega$
- 15.64** Two circuit elements in parallel consume 90 VAR when connected to a 120-V, 60-Hz source. If the reactive factor is 0.8, what are the two components and what are their values?
Ans. A 213- Ω resistor and a 0.424-H inductor
- 15.65** Two circuit elements in series consume -80 VAR when connected to a 240-V, 60-Hz source. If the reactive factor is -0.7 , what are the two components and what are their values?
Ans. A 360- Ω resistor and a 7.52- μF capacitor
- 15.66** A 300-mA, 60-Hz current flows through a 10- μF capacitor. Find the average, peak, and reactive powers absorbed.
Ans. $P = 0$ W, $p_{\max} = 23.9$ W, $Q = -23.9$ VAR
- 15.67** What are the power components resulting from a 3.6-A current flowing through a load of $50/\underline{-30} \ \Omega$?
Ans. $S = 648/\underline{-30}$ VA, $S = 648$ VA, $P = 561$ W, $Q = -324$ VAR
- 15.68** Find the power components of a fully loaded 10-hp synchronous motor operating at an 87 percent efficiency and a 0.7 leading power factor.
Ans. $S = 12.2/\underline{-45.6}$ kVA, $S = 12.2$ kVA, $P = 8.57$ kW, $Q = -8.74$ kVAR
- 15.69** A load draws 3 A with 75 V applied. If the load power factor is 0.6 lagging, find the power components of the load.
Ans. $S = 225/\underline{53.1}$ VA, $S = 225$ VA, $P = 135$ W, $Q = 180$ VAR
- 15.70** Find the power components of a load that draws $8.1/\underline{36}$ A with $480/\underline{10}$ V applied.
Ans. $S = 3.89/\underline{-26}$ kVA, $S = 3.89$ kVA, $P = 3.49$ kW, $Q = -1.7$ kVAR
- 15.71** A 120-mH inductor and a parallel 30- Ω resistor draw 6.1 A at 60-Hz. Find the power components.
Ans. $S = 930/\underline{33.6}$ VA, $S = 930$ VA, $P = 775$ W, $Q = 514$ VAR
- 15.72** A fully loaded 15-hp induction motor operates from a 480-V, 60-Hz line at an efficiency of 83 percent and a 0.7 lagging power factor. Find the overall power factor when a 75- μF capacitor is placed in parallel with the motor.
Ans. 0.881 lagging
- 15.73** Two loads are connected in parallel across a 277-V line. One is a fully loaded 5-hp induction motor that operates at an 80 percent efficiency and a 0.7 lagging power factor. The other is a 5-kW resistive heater. Find the overall power factor and line current.
Ans. 0.897 lagging, 38.9 A
- 15.74** Two loads are connected in parallel across a 12 470-V line. One load takes 23 kVA at a 0.75 lagging power factor and the other load takes 10 kVA at a 0.6 leading power factor. Find the total line current and also the impedance of the combination.
Ans. 1.95 A, $6.39/\underline{17.2}$ k Ω

- 15.75** Three loads are connected across a 480-V line. One is a fully loaded 10-hp induction motor operating at an 80 percent efficiency and a 0.6 lagging power factor. Another is a fully loaded 5-hp synchronous motor operating at a 75 percent efficiency and a 0.6 leading power factor. The third is a 7-kW resistive heater. Find the total line current and the overall power factor.

Ans. 46 A, 0.965 lagging

- 15.76** In the circuit shown in Fig. 15-10, load 1 absorbs 6.3 kW and 9.27 kVAR, and load 2 absorbs 5.26 kW and generates 2.17 kVAR. Find the total power components, the source voltage V , and the impedance of each load.

Ans. $S_T = 13.6/31.6$ kVA $S_T = 13.6$ kVA $P_T = 11.6$ kW $Q_T = 7.1$ kVAR
 $V = 2.21/\underline{-13.4}$ kV $Z_1 = 437/\underline{55.8}$ Ω $Z_2 = 861/\underline{-22.4}$ Ω

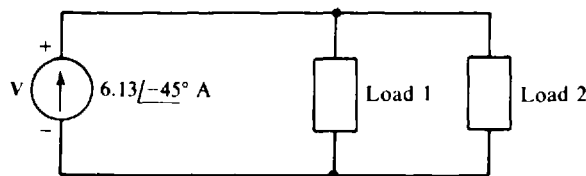

Fig. 15-10

- 15.77** How much reactive power must be supplied by parallel capacitors to a 50-kVA load with a 0.65 lagging power factor to increase the overall power factor to 0.85 lagging?

Ans. 17.9 kVAR

- 15.78** An electric motor delivers 50 hp while operating from a 480-V line at an 83 percent efficiency and a 0.65 lagging power factor. If it is paralleled with a capacitor that increases the overall power factor to 0.9 lagging, what is the decrease in line current?

Ans. 40 A

- 15.79** A load energized from a 480-V, 60-Hz line has a power factor of 0.6 lagging. If placing a 100- μ F capacitor across the line raises the overall power factor to 0.85 lagging, find the real power of the load and the decrease in line current.

Ans. 12.2 kW, 12.4 A

- 15.80** A factory draws 90 A at a 0.75 lagging power factor from a 25 000-V, 60-Hz line. Find the capacitance of a parallel capacitor that will increase the overall power factor to 0.9 lagging.

Ans. 2.85 μ F

- 15.81** A fully loaded 75-hp induction motor operates from a 480-V, 60-Hz line at an 80 percent efficiency and a 0.65 lagging power factor. The power factor is to be raised to 0.9 lagging by placing a capacitor across the motor terminals. Find the capacitance required and the resulting decrease in line current.

Ans. 551 μ F, 62.2 A

- 15.82** A load of $50/\underline{60}$ Ω is connected to a 480-V, 60-Hz source. What capacitor connected in parallel with the load will produce an overall power factor of 0.9 lagging?

Ans. 33.1 μ F

- 15.83** At 400 Hz, what is the power factor of the circuit shown in Fig. 15.11? What capacitor connected across the input terminals causes the overall power factor to be 0.9 lagging?

Ans. 0.77 lagging, 8.06 μF

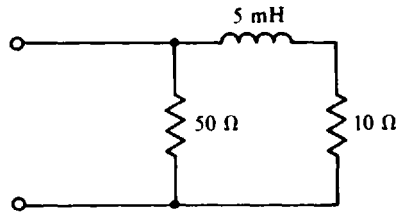

Fig. 15-11

- 15.84** For a load energized by a 277-V, 60-Hz source, an added parallel $5\text{-}\mu\text{F}$ capacitor improves the power factor from 0.65 lagging to 0.9 lagging. What is the source current both before and after the capacitor is added?

Ans. 1.17 A, 0.847 A

Transformers

INTRODUCTION

A *transformer* has two or more windings, also called coils, that are magnetically coupled. As shown in Fig. 16-1, a typical transformer has two windings wound on a core that may be made from iron. Each winding encirclement of the core is called a *turn*, and is designated by N . Here, winding 1 has $N_1 = 4$ turns and winding 2 has $N_2 = 3$ turns. (Windings of practical transformers have many more turns than these.) Circuit 1, connected to winding 1, is often a source, and circuit 2, connected to winding 2, is often a load. In this case, winding 1 is called the *primary winding* or just *primary*, and winding 2 is called the *secondary winding* or just *secondary*.

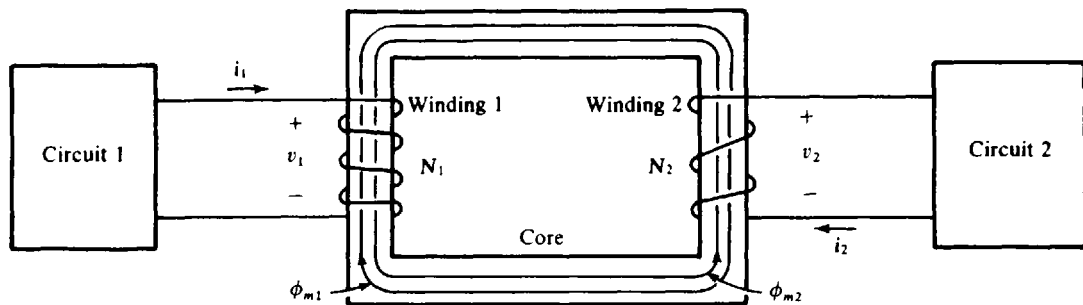

Fig. 16-1

In the operation, current i_1 flowing in winding 1 produces a magnetic flux ϕ_{m1} that, for power transformers, is ideally confined to the core and so passes through or couples winding 2. The m in the subscript means “mutual”—the flux is *mutual* to both windings. Similarly, current i_2 flowing in winding 2 produces a flux ϕ_{m2} that couples winding 1. When these currents change in magnitude or direction, they produce corresponding changes in the fluxes and these changing fluxes induce voltages in the windings. In this way, the transformer couples circuit 1 and circuit 2 so that electric energy can flow from one circuit to the other.

Although flux is a convenient aid for understanding transformer operation, it is not used in the analyses of transformer circuits. Instead, either transformer turns ratios or inductances are used, as will be explained.

Transformers are very important electrical components. At high efficiencies, they change voltage and current levels, which is essential for electric power distribution. In electronic applications they match load impedances to source impedances for maximum power transfer. And they couple amplifiers together without any direct metallic connections that would conduct dc currents. At the same time they may act with capacitors to filter signals.

RIGHT-HAND RULE

In Fig. 16-1 the flux ϕ_{m1} produced by i_1 has a clockwise direction, but ϕ_{m2} produced by i_2 has a counterclockwise direction. The direction of the flux produced by current flowing in a winding can be determined from a version of the *right-hand rule* that is different from that presented in Chap. 9 for a single wire. As shown in Fig. 16-2, if the fingers of a right hand encircle a winding in the direction of the current, the thumb points in the direction of the flux produced in the winding by the current.

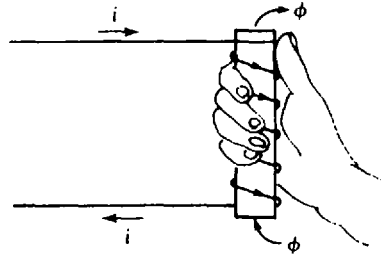

Fig. 16-2

DOT CONVENTION

Using dots at winding terminals in agreement with the *dot convention* is a convenient method for specifying winding direction relations. One terminal of each winding is dotted, with the dotted terminals selected such that *currents flowing into the dotted terminals produce adding fluxes*. Because these dots specify the transformer winding relations, they are used in circuit diagrams with inductor symbols in place of illustrated windings. A transformer circuit diagram symbol consists of two adjacent inductor symbols with dots. If the winding relations are not important, the dots may be omitted.

Figure 16-3 shows the use of dots. In a circuit diagram, the more convenient transformer representation with dots in Fig. 16-3*b* is used instead of the one with windings in Fig. 16-3*a*. But both are equivalent. An actual transformer may have some marking other than dots. In Fig. 16-3*b*, the two vertical lines between the inductor symbols designate the transformer as either an iron-core transformer or an ideal transformer, which is considered next.

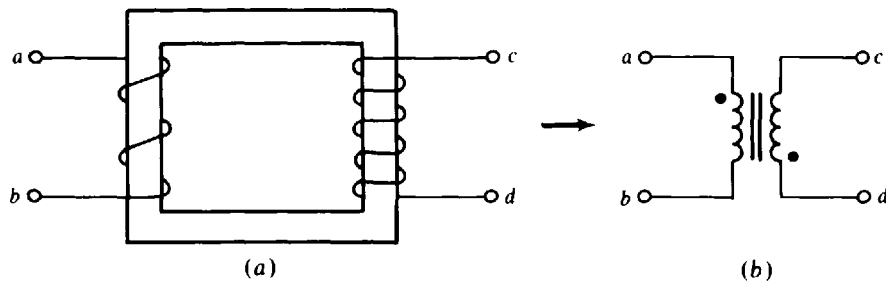

Fig. 16-3

THE IDEAL TRANSFORMER

In most respects, an *ideal transformer* is an excellent model for a transformer with an iron core — an *iron-core transformer*. Power transformers, the transformers used in electric power distribution systems, are iron-core transformers. Being a model, an ideal transformer is a convenient approximation of the real thing. The approximations are zero winding resistance, zero core loss, and infinite core permeability. Having windings of zero resistance, an ideal transformer has no winding ohmic power loss (I^2R loss) and no resistive voltage drops. The second property, zero core loss, means that there is no power loss in the core — no hysteresis or eddy-current losses. And since there is no power loss in the windings either, there is no power loss in the entire ideal transformer — the power out equals the power in. The third and last feature, infinite core permeability, means that no current is required to establish the magnetic flux to produce the induced voltages. It also means that all the magnetic flux is confined to the core, coupling both windings. All flux is mutual, and there is no *leakage flux*, which is flux that couples only one winding.

In the analysis of a circuit containing an ideal transformer, the transformer *turns ratio*, also called *transformation ratio*, is used instead of flux. The turns ratio, with symbol a , is $a = N_1 / N_2$. This is the

ratio of the number of primary turns to secondary turns. In many electric circuits books, however, this ratio is defined as the number of secondary turns to primary turns, and sometimes the symbol n or N is used.

In a circuit diagram, the turns ratio of an iron-core or ideal transformer is specified over the transformer symbol by a designation such as 20:1, which means that the winding on the left of the vertical bars has 20 times as many turns as the winding on the right. If the designation were 1:25, instead, the winding on the right would have 25 times as many turns as the winding on the left.

The turns ratio is convenient because it relates the winding voltages. By Faraday's law, $v_1 = \pm N_1 d\phi/dt$ and $v_2 = \pm N_2 d\phi/dt$. (The same flux ϕ is in both equations because an ideal transformer has no leakage flux.) The ratio of these equations is

$$\frac{v_1}{v_2} = \pm \frac{N_1 (d\phi/dt)}{N_2 (d\phi/dt)} = \pm \frac{N_1}{N_2} = \pm a$$

The positive sign must be selected when both dotted terminals have the same reference voltage polarity. Otherwise the negative sign must be selected. The justification for this selection is that, as can be shown by Lenz's law, at any one time the dotted terminals of an ideal transformer always have the same actual polarities—either both positive or both negative with respect to the other terminals. Incidentally, these actual polarities have nothing to do with the selection of voltage reference polarities, which is completely arbitrary.

It is obvious from $v_1/v_2 = \pm a$ that if a transformer has a turns ratio less than one ($a < 1$), the secondary rms voltage is greater than the primary rms voltage. Such a transformer is called a *step-up transformer*. But if the turns ratio is greater than one ($a > 1$), the secondary rms voltage is less than the primary rms voltage, and the transformer is called a *step-down transformer*.

As can be shown from the property of infinite permeability, or from zero power loss, the primary and secondary currents have a relation that is the inverse of that for the primary and secondary voltages. Specifically,

$$\frac{i_2}{i_1} = \pm \frac{N_1}{N_2} = \pm a$$

The positive sign must be selected if one current reference is into a dotted terminal and the other current reference is out of a dotted terminal. Otherwise the negative sign must be selected. The reason for this selection is that, at any one time, actual current flow is into the dotted terminal of one winding and out of the dotted terminal of the other. So, only the specified selection of signs will give the correct signs for the currents. But this selection of signs has nothing to do with the selection of current reference directions, which is completely arbitrary.

It is important to remember that the winding with the greater number of turns has more voltage but less current.

In the analysis of a circuit containing ideal transformers, a common approach is to eliminate the transformers by reflecting impedances and, if necessary, sources. This approach applies only if there are no current paths between the primary and secondary circuits, as is usually the case. For an understanding of this reflecting approach, consider the circuit shown in Fig. 16-4a. The impedance Z_r , "looking into" the primary winding, is called the *reflected impedance*,

$$Z_r = \frac{V_1}{I_1} = \frac{-aV_2}{(-1/a)I_2} = a^2 \frac{V_2}{I_2} = a^2 Z_2$$

which is the turns ratio squared times the secondary circuit impedance Z_2 . If Z_r replaces the primary winding, as shown in Fig. 16-4b, the primary current I_1 is unchanged. As can be proven by trying all different dot arrangements, the dot locations have no effect on this reflected impedance.

So if the primary circuit voltages and currents are of interest, the transformer can be eliminated by replacing the transformer primary winding with the reflected impedance of the secondary circuit, assuming this circuit contains no independent sources. The resulting primary circuit can be analyzed in

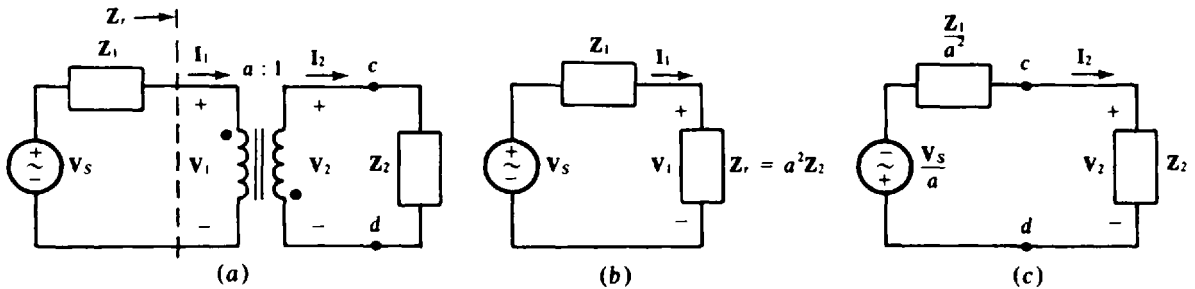

Fig. 16-4

the usual manner. Then if the secondary winding voltage and current are also of interest, they can be obtained from the primary winding voltage and current.

If the secondary circuit is not a lumped impedance, but a circuit with individual resistive and reactive components, the total impedance can be found and reflected. Alternatively, the whole secondary circuit can be reflected into the primary circuit. In this reflection, the circuit configuration is kept the same and each individual impedance is multiplied by the square of the turns ratio. Of course, the transformer is eliminated.

Reflection can also be from the primary to the secondary. To see this, consider making cuts at terminals c and d in the circuit shown in Fig. 16-4a and finding the Thévenin equivalent of the circuit to the left. Because of the open circuit created by the cuts, the secondary current is zero: $I_2 = 0$ A, which in turn means that the primary current is zero: $I_1 = 0$ A. Consequently, there is 0 V across Z_1 and all the source voltage is across the primary winding. As a result, the Thévenin voltage referenced positive toward terminal c is $V_{Th} = V_2 = -V_1/a = -V_s/a$. From impedance reflection the Thévenin impedance is $Z_{Th} = Z_1/a^2$, with a^2 being in the denominator instead of the numerator because the winding being “looked into” is the secondary winding. The result is shown in the circuit of Fig. 16-4c. Note that the source voltage polarity reverses because the dots are at opposite ends of the windings. By use of Norton’s theorem in a similar way, it can be shown that a source of current I_s would have reflected into the secondary as aI_s and would have been reversed in direction because the dots are not at the same ends of the windings. Whole circuits can be reflected in this way.

An alternative to the reflection analysis approach is to write the circuit equations, which are usually mesh equations, with the transformer voltages and currents as variables. Since the number of unknowns will exceed the number of equations, these equations must be augmented with the transformer voltage and current turns-ratio equations. As an illustration, for the circuit of Fig. 16-4a, these equations are

$$\begin{aligned} Z_1 I_1 + V_1 &= V_s \\ Z_2 I_2 - V_2 &= 0 \\ V_1 + aV_2 &= 0 \\ aI_1 + I_2 &= 0 \end{aligned}$$

The fact that this approach requires more equations than does the reflection approach is not a significant disadvantage if an advanced scientific calculator is used in the calculations, and this approach may be easier overall.

For ac voltages and currents, an ideal transformer gives results that are within a few percent of those of the corresponding actual power transformer. But for dc voltages and currents, an ideal transformer gives incorrect results. The reason is that an ideal transformer will transform dc voltages and currents while an actual transformer will not.

THE AIR-CORE TRANSFORMER

The ideal transformer approximation is not valid for a transformer with a core constructed of nonmagnetic material, as may be required for operation at radio and higher frequencies. A transformer with such a core is often called an *air-core transformer* or a *linear transformer*.

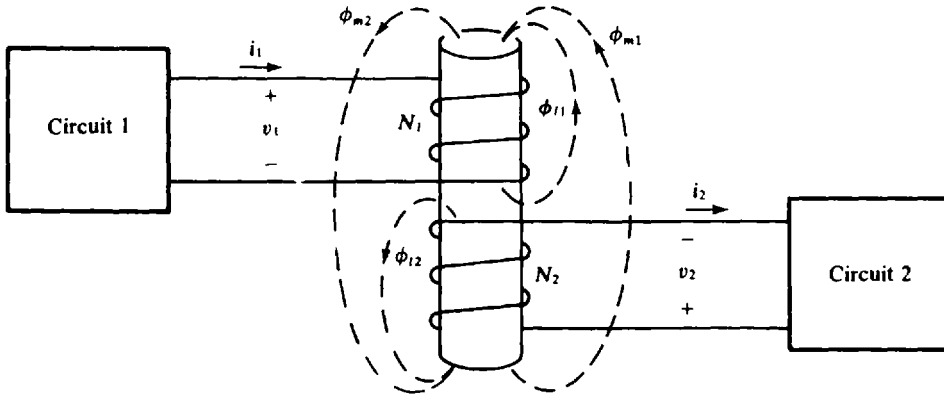

Fig. 16-5

Figure 16-5 shows two circuits coupled by an air-core transformer. Current i_1 produces a mutual flux ϕ_{m1} and a leakage flux ϕ_{l1} , and current i_2 produces a mutual flux ϕ_{m2} and leakage flux ϕ_{l2} . As mentioned, a mutual flux couples both windings, but a leakage flux couples only one winding.

The *coefficient of coupling*, with symbol k , indicates the closeness of coupling, which in turn means the fraction of total flux that is mutual. Specifically,

$$k = \sqrt{\frac{\phi_{m1}}{\phi_{l1} + \phi_{m1}} \times \frac{\phi_{m2}}{\phi_{l2} + \phi_{m2}}}$$

Clearly k cannot have a value greater than 1 or less than 0. And the greater each fraction of mutual flux, the greater the coefficient of coupling. The coefficient of coupling of a good power transformer is very close to 1, but an air-core transformer typically has a coefficient of coupling less than 0.5.

The voltages induced by changing fluxes are given by Faraday's law:

$$v_1 = \pm N_1 \frac{d}{dt} (\phi_{m1} + \phi_{l1} \pm \phi_{m2}) \quad v_2 = \pm N_2 \frac{d}{dt} (\phi_{m2} + \phi_{l2} \pm \phi_{m1})$$

The positive signs in $\pm \phi_{m2}$ and $\pm \phi_{m1}$ are selected if and only if both mutual fluxes have the same direction in each winding.

For circuit analysis, it is better to use inductances instead of fluxes. The *self-inductances* of the windings are

$$L_1 = \frac{N_1(\phi_{m1} + \phi_{l1})}{i_1} \quad L_2 = \frac{N_2(\phi_{m2} + \phi_{l2})}{i_2}$$

These are just the ordinary winding inductances as defined in Chap. 9. There is, however, another inductance called the *mutual inductance* with symbol M . It accounts for the flux linkages of one winding caused by current flow in the other winding. Specifically,

$$M = \frac{N_1 \phi_{m2}}{i_2} = \frac{N_2 \phi_{m1}}{i_1}$$

With these substitutions, the voltage equations become

$$v_1 = L_1 \frac{di_1}{dt} \pm M \frac{di_2}{dt} \quad \text{and} \quad v_2 = L_2 \frac{di_2}{dt} \pm M \frac{di_1}{dt}$$

in which the \pm signs for the $L di/dt$ terms have been deleted because of the assumption of associated voltage and current references. For a sinusoidal analysis the corresponding equations are

$$\mathbf{V}_1 = j\omega L_1 \mathbf{I}_1 \pm j\omega M \mathbf{I}_2 \quad \text{and} \quad \mathbf{V}_2 = j\omega L_2 \mathbf{I}_2 \pm j\omega M \mathbf{I}_1$$

In these equations, the negative signs of \pm are used if one current has a reference into a dotted terminal and the other has a reference out of a dotted terminal. Otherwise the positive signs are used. Put another way, if positive i_1 and i_2 or I_1 and I_2 produce adding mutual fluxes, then the L and M terms add. As mentioned, these equations are based on associated voltage and current references. If a pair of these references are not associated, the v or V of the corresponding equation should have a negative sign. Everything else, though, remains the same.

In a time-domain circuit diagram the self-inductances are specified adjacent to the corresponding windings in the usual manner. The mutual inductances are specified with arrows to designate which pair of windings each mutual inductance is for. In a phasor-domain circuit, of course, $j\omega L_1$, $j\omega L_2$, and $j\omega M$ are used instead of L_1 , L_2 , and M .

If substitutions are made for the fluxes in the coefficient of coupling equation, the result is $k = M/\sqrt{L_1 L_2}$.

Mesh and loop analyses are best for analyzing circuits containing air-core transformers since nodal analysis is difficult to use. Writing the KVL equations is the same as for other circuits except for the necessity of including the $j\omega MI$ terms resulting from the magnetic coupling. Also, voltage variables are *not* assigned to the windings.

If the secondary circuit contains no independent sources and no current paths to the primary circuit, it is possible to reflect impedances in a manner similar to that used for ideal transformers. For an understanding of this reflection, consider the circuit shown in Fig. 16-6. The mesh equations are

$$\begin{aligned} \mathbf{V}_S &= (\mathbf{Z}_1 + j\omega L_1)\mathbf{I}_1 - j\omega M\mathbf{I}_2 \\ 0 &= -j\omega M\mathbf{I}_1 + (j\omega L_2 + \mathbf{Z}_L)\mathbf{I}_2 \end{aligned}$$

The mutual terms are negative in both equations because one winding current is referenced into a dotted terminal while the other is referenced out of a dotted terminal. If \mathbf{I}_2 is solved for in the second equation and a substitution made for \mathbf{I}_2 in the first equation, the result is

$$\mathbf{V}_S = \left(\mathbf{Z}_1 + j\omega L_1 + \frac{\omega^2 M^2}{j\omega L_2 + \mathbf{Z}_L} \right) \mathbf{I}_1$$

which indicates that the secondary circuit reflects into the primary circuit as an impedance $\omega^2 M^2 / (j\omega L_2 + \mathbf{Z}_L)$ in series with the primary winding. As can be found by trying different dot locations, this impedance does not depend on those locations. Some authors of circuits books call this impedance a "reflected impedance." Others, however, use the term "coupled impedance."

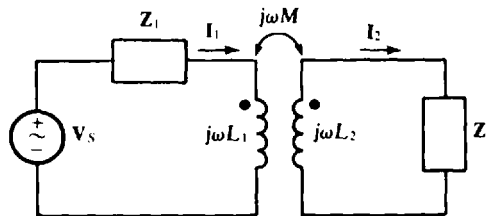

Fig. 16-6

THE AUTOTRANSFORMER

An *autotransformer* is a transformer with a single winding that has an intermediate terminal that divides the winding into two sections. For an understanding of autotransformer operation, it helps to consider the two sections of the winding to be the two windings of a power transformer, as is done next.

Consider a 50-kVA power transformer that has a voltage rating of 10 000/200 V. From the kVA and voltage ratings, the full-load current of the high voltage winding is $50\,000/10\,000 = 5\text{ A}$ and that of the low voltage winding is $50\,000/200 = 250\text{ A}$. Figure 16-7*a* shows such a transformer, fully loaded, with its windings connected such that the dotted end of one winding is connected to the undotted end of the other. As shown, the 10 000-V secondary circuit can be loaded to a maximum of $250 + 5 = 255\text{ A}$ without either of the windings being current overloaded. Since the source current is 250 A, the transformer can deliver $10\,200 \times 250 = 2550\text{ kVA}$. This can also be determined from the secondary circuit: $10\,000 \times 255 = 2550\text{ kVA}$. In effect, the autotransformer connection has increased the transformer kVA rating from 50 to 2550 kVA.

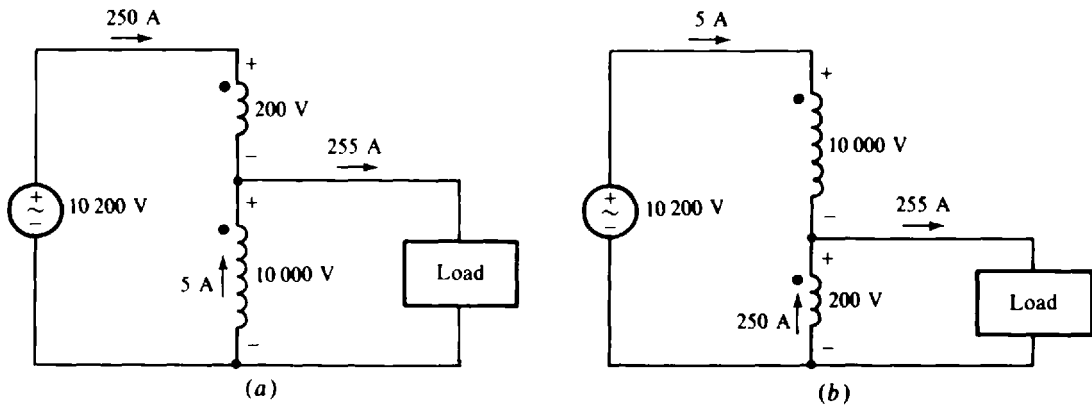

Fig. 16-7

The explanation for this increase is that the original 50-kVA transformer had no metallic connections between the two windings, and so the 50 kVA of a full load had to pass through the transformer by magnetic coupling. But with the windings connected to provide autotransformer operation, there is a metallic connection between the windings that passes $2550 - 50 = 2500\text{ kVA}$ without being magnetically transformed. So, it is the direct metallic connection that provides the kVA increase. Although advantageous in this respect, such a connection destroys the isolation property that conventional transformers have, which in turn means that autotransformers cannot be used in every transformer application.

If the windings are connected as in Fig. 16-7*b*, the kVA rating is just $10\,200 \times 5 = 200 \times 255 = 51\text{ kVA}$. This slight increase of 2 percent in kVA rating is the result of the greatly different voltage levels of the two circuits connected to the autotransformer. In general, the closer the voltage levels are to being the same, the greater the increase in kVA rating. This is why autotransformers are used as links between power systems usually only if the systems are operating at nearly the same voltage levels.

In Fig. 16-7*a*, the load and the voltage source can be interchanged. Then the load is connected across both windings and the voltage source across just one. This arrangement is used when the load voltage is greater than the source voltage. The increase in kVA rating is the same.

In the analysis of a circuit containing an autotransformer, an ideal transformer model can be assumed, and its turns ratio used in much the same way as for a conventional transformer connection. Along with this can be used the fact that the lines with the lower voltage carry the sum of the two winding currents. Also, part of the winding carries only the difference of the source and load currents. This is the part that is common to both the source and load circuits.

Contrary to what Fig. 16-7 suggests, autotransformers are preferably purchased as such and not constructed from conventional power transformers. An exception, however, is the “buck and boost” transformer. A typical one can be used to reduce 120 or 240 V to 12 or 24 V. The principal use, though,

is as an autotransformer with the primary and secondary interconnected to give a slight adjustment in voltage, either greater or lesser.

PSPICE AND TRANSFORMERS

PSpice does not have a built-in ideal transformer component, but a model for one can be constructed with dependent sources. To see how to do this, consider the ideal transformer of Fig. 16-8a. There are, of course, just two constraints on its operation: $v_1 = -av_2$ and $i_2 = ya_i i_1$, as obtained from the turns ratio and also the dot locations. As shown in Fig. 16-8b, and also in Fig. 16-8c, these constraints can be satisfied with two dependent sources: a voltage-controlled voltage source to obtain the voltage constraint and a current-controlled current source to obtain the current constraint. Also needed is a dummy voltage source to sense the controlling current. Naturally, if the dot locations are at the same ends of the windings, instead of opposite ends as in Fig. 16-8a, the polarity of the dependent voltage source and the current direction of the dependent current source must be reversed.

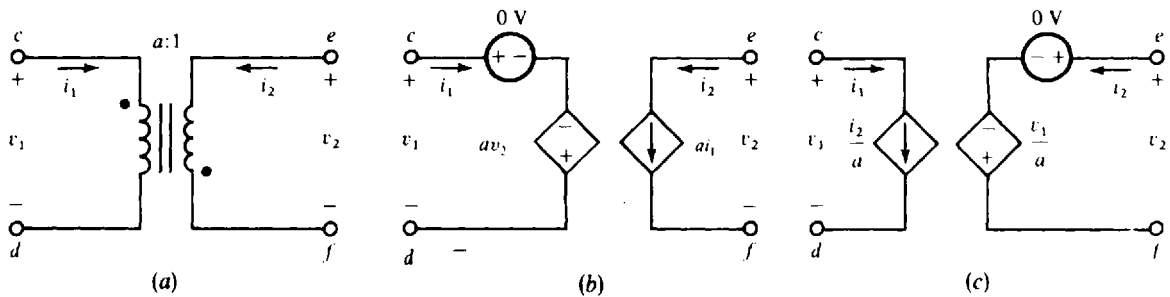

Fig. 16-8

PSpice does provide for an air-core transformer. Self-inductance statements are used for the two windings in the same manner as for ordinary inductors. The ordering of the node numbers informs PSpice of the dot locations, with the first node being at the dot location. The only other requirement is a coefficient of coupling statement that has a name beginning with the letter K. Following this name are the names of the two coupled inductors, in either order. Last is the coefficient of coupling. For example, the following statements could be used for the air-core transformer of Fig. 16-9.

```
L1 7 8 90M
L2 11 5 40M
K1 L1 L2 0.5
```

The indicated coefficient of coupling of 0.5 is obtained from $k = M/\sqrt{L_1 L_2} = 30/\sqrt{90 \times 40} = 0.5$, where the inductances are expressed in millihenries.

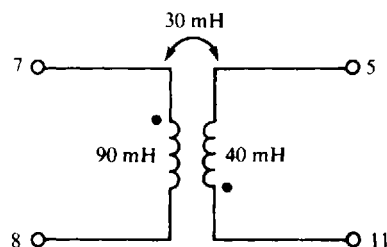

Fig. 16-9

Solved Problems

- 16.1** For the winding shown in Fig. 16-10a, what is the direction of flux produced in the core by current flowing into terminal *a*?

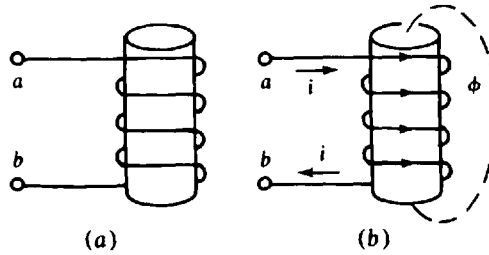

Fig. 16-10

Current that flows into terminal *a* flows over the core to the right, underneath to the left, then over the core to the right again, and so on, as is shown in Fig. 16-10b. For the application of the right-hand rule, fingers of a right hand should be imagined grasping the core with the fingers directed from left to right over the core. Then the thumb will point up, which means that the direction of the flux is up *inside* the core.

- 16.2** Supply the missing dots for the transformers shown in Fig. 16-11.

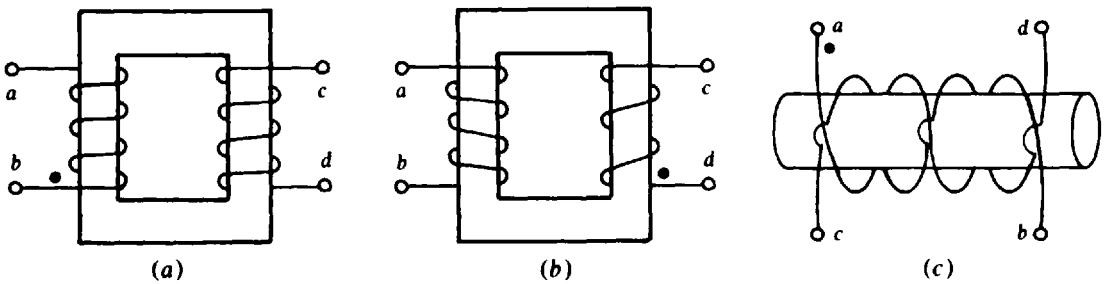

Fig. 16-11

- (a) By the right-hand rule, current flowing into dotted terminal *b* produces clockwise flux. By trial and error it can be found that current flowing into terminal *c* also produces clockwise flux. So, terminal *c* should have a dot.
- (b) Current flowing into dotted terminal *d* produces counterclockwise flux. Since current flowing into terminal *b* also produces counterclockwise flux, terminal *b* should have a dot.
- (c) Current flowing into dotted terminal *a* produces flux to the right inside the core. Since current flowing into terminal *d* also produces flux to the right inside the core, terminal *d* should have a dot.

- 16.3** What is the turns ratio of a transformer that has a 684-turn primary winding and a 36-turn secondary winding?

The turns ratio *a* is the ratio of the number of primary turns to secondary turns: $a = 684/36 = 19$.

- 16.4** Find the turns ratio of a transformer that transforms the 12 470 V of a power line to the 240 V supplied to a house.

Since the high-voltage winding is connected to the power lines, it is the primary. The turns ratio is equal to the ratio of the primary to secondary voltages: $a = 12\,470/240 = 51.96$.

- 16.5** What are the full-load primary and secondary currents of a 25 000/240-V, 50-kVA transformer? Assume, of course, that the 25 000-V winding is the primary.

The current rating of a winding is the transformer kVA rating divided by the winding voltage rating. So, the full-load primary current is $50\,000/25\,000 = 2$ A, and the full-load secondary current is $50\,000/240 = 208$ A.

- 16.6** A power transformer with a voltage rating of 12 500/240 V has a primary current rating of 50 A. Find the transformer kVA rating and the secondary current rating if the 240 V is the secondary voltage rating.

The transformer has a kVA rating that is equal to the product of the primary voltage rating and the primary current rating: $12\,500(50) = 625\,000$ VA = 625 kVA. Since this is also equal to the product of the secondary voltage and current ratings, the secondary current rating is $625\,000/240 = 2.6 \times 10^3$ A = 2.6 kA. As a check, the secondary current rating is equal to the primary current rating times the turns ratio, which is $a = 12\,500/240 = 52.1$. So the secondary current rating is $52.1(50) = 2.6 \times 10^3$ A = 2.6 kA, which checks.

- 16.7** A transformer has a 500-turn winding linked by flux changing at the rate of 0.4 Wb/s. Find the induced voltage.

If the polarity of the voltage is temporarily ignored, then by Faraday's law, $v = N d\phi/dt$. The quantity $d\phi/dt$ is the time rate of change of flux, which is specified as 0.4 Wb/s. So, $v = 500(0.4) = 200$ V; the magnitude of the induced voltage is 200 V. The voltage polarity can be either positive or negative depending on the voltage reference polarity, the direction of the winding, and the direction in which the magnetic flux is either decreasing or increasing, none of which are specified. So the most that can be determined is that the magnitude of the induced voltage is 200 V at the time that the flux is changing at the rate of 0.4 Wb/s.

- 16.8** An iron-core transformer has 400 primary turns and 100 secondary turns. If the applied primary voltage is 240 V rms at 60 Hz, find the secondary rms voltage and the peak magnetic flux.

Since the transformer has an iron core, the turns ratio can be used to find the secondary rms voltage: $V_2 = (1/a)V_1 = (100/400)(240) = 60$ V rms. Because the voltages vary sinusoidally, they are induced by a sinusoidally varying flux that can be considered to be $\phi = \phi_m \sin \omega t$, where ϕ_m is the peak value of flux and ω is the radian frequency of $\omega = 2\pi(60) = 377$ rad/s. The time rate of change of flux is $d\phi/dt = d(\phi_m \sin \omega t)/dt = \omega\phi_m \cos \omega t$, which has a peak value of $\omega\phi_m$. Since the peak voltage is $\sqrt{2}V_{\text{rms}}$, it follows from $v = N d\phi/dt$ that the peak voltage and flux values are related by $\sqrt{2}V_{\text{rms}} = N\omega\phi_m$. If ϕ_m is solved for and primary quantities used, the result is

$$\phi_m = \frac{\sqrt{2}V_{\text{rms}}}{N\omega} = \frac{\sqrt{2}(240)}{400(377)} = 2.25 \times 10^{-3} \text{ Wb} = 2.25 \text{ mWb}$$

Alternatively, the secondary voltage and turns could have been used since the same flux is assumed to couple both windings.

Incidentally, from $\sqrt{2}V_{\text{rms}} = N\omega\phi_m$, the voltage V_{rms} can be expressed as

$$V_{\text{rms}} = \frac{N(2\pi f)\phi_m}{\sqrt{2}} = 4.44fN\phi_m$$

This is called the *general transformer equation*.

- 16.9** If a 50-turn transformer winding has a 120-V rms applied voltage, and if the peak coupling flux is 20 mWb, find the frequency of the applied voltage.

From rearranging the general transformer equation defined in Prob. 16.8.

$$f = \frac{V_{rms}}{4.44 N \phi_m} = \frac{120}{4.44(50)(20 \times 10^{-3})} = 27 \text{ Hz}$$

- 16.10** An iron-core transformer has 1500 primary turns and 500 secondary turns. A 12-Ω resistor is connected across the secondary winding. Find the resistor voltage when the primary current is 5 A.

Since no voltage or current references are specified, only rms values are of interest and are to be assumed without specific mention of them. The secondary current is equal to the turns ratio times the primary current: $(1500/500)(5) = 15 \text{ A}$. When this current flows through the 12-Ω resistor, it produces a voltage of $15(12) = 180 \text{ V}$.

- 16.11** The output stage of an audio system has an output resistance of 2 kΩ. An output transformer provides resistance matching with a 6-Ω speaker. If this transformer has 400 primary turns, how many secondary turns does it have?

The term “resistance matching” means that the output transformer presents a reflected resistance of 2 kΩ to the output audio stage so that there is maximum power transfer to the 6-Ω speaker. Since, in general, the reflected resistance R_r is equal to the turns ratio squared times the resistance R_L of the load connected to the secondary ($R_r = a^2 R_L$), the turns ratio of the output transformer is

$$a = \sqrt{\frac{R_r}{R_L}} = \sqrt{\frac{2000}{6}} = 18.26$$

and the number of secondary turns is

$$N_2 = \frac{N_1}{a} = \frac{400}{18.26} = 22$$

- 16.12** In the circuit shown in Fig. 16-12, find R for maximum power absorption. Also, find \mathbf{I} for $R = 3 \Omega$. Finally, determine if connecting a conductor between terminals d and f would change these results.

The value of R for maximum power absorption is that value for which the reflected resistance $a^2 R$ is equal to the source resistance of 27 Ω. Since the primary winding has 4 turns, and the secondary winding has 2 turns, the turns ratio is $a = N_1/N_2 = 4/2 = 2$. And, from $27 = 2^2 R$, the value of R for maximum power absorption is $R = 27/4 = 6.75 \Omega$.

For $R = 3 \Omega$, the reflected resistance is $2^2(3) = 12 \Omega$. So the primary current directed into terminal c is $(216/\underline{0})/(27 + 12) = 5.54/\underline{0} \text{ A}$. If terminal c is dotted, then terminal e should be dotted, as is evident from the right-hand rule. And, since \mathbf{I} is directed out of terminal e while the calculated current is into terminal c , \mathbf{I} is just the turns ratio times the current entering terminal c : $\mathbf{I} = 2(5.54/\underline{0}) = 11.1/\underline{0} \text{ A}$.

A conductor connected between terminals d and f does not affect these results since current cannot flow in a single conductor. For current to flow there would have to be another conductor to provide a return path.

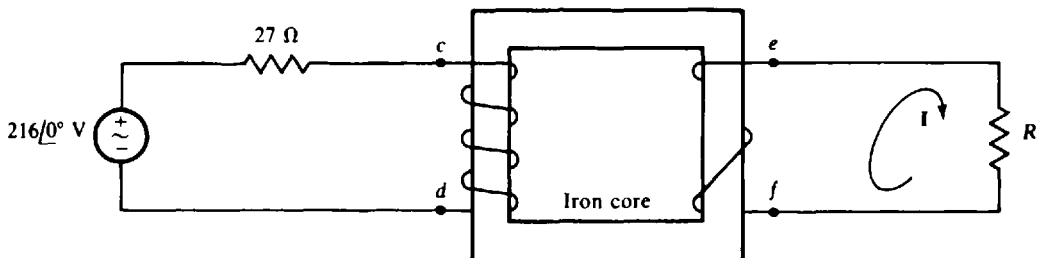

Fig. 16-12

16.13 Find i_1 , i_2 , and i_3 for the circuit shown in Fig. 16-13. The transformers are ideal.

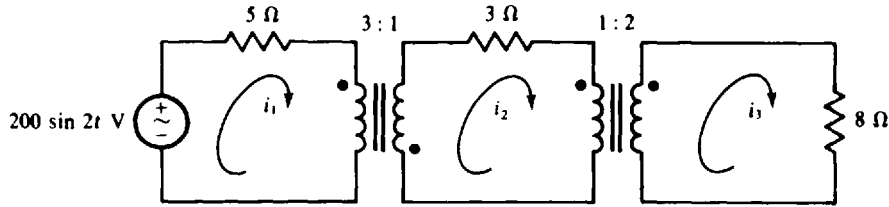

Fig. 16-13

A good procedure is to find i_1 using reflected resistances, then find i_2 from i_1 , and last find i_3 from i_2 . The $8\ \Omega$ reflects into the middle circuit as $8 \cdot 2^2 = 2\ \Omega$, making a total resistance of $2 + 3 = 5\ \Omega$ in the middle circuit. This $5\ \Omega$ reflects into the source circuit as $3^2(5) = 45\ \Omega$. Consequently,

$$i_1 = \frac{200 \sin 2t}{5 + 45} = 4 \sin 2t \text{ A}$$

Because i_1 and i_2 both have reference directions into dotted terminals of the first transformer, i_2 is equal to the negative of the turns ratio times i_1 : $i_2 = -3(4 \sin 2t) = -12 \sin 2t$ A. Finally, since i_2 has a reference direction into a dotted terminal of the second transformer, and i_3 has a reference direction out of a dotted terminal of this transformer, i_3 is equal to the turns ratio ($1:2 = 0.5$) times i_2 : $i_3 = 0.5(-12 \sin 2t) = -6 \sin 2t$ A.

16.14 Find I_1 and I_2 for the circuit shown in Fig. 16-14.

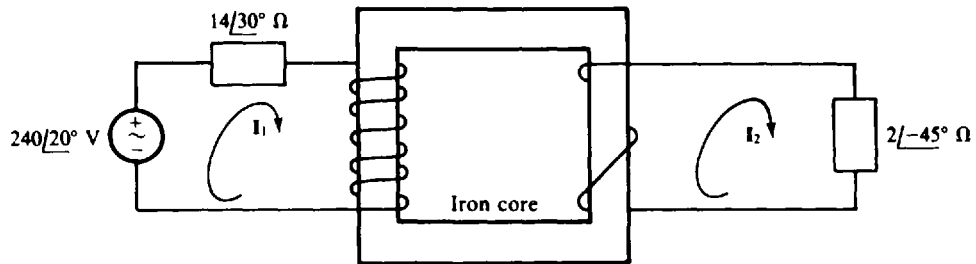

Fig. 16-14

Because the primary has 6 turns and the secondary has 2 turns, the turns ratio is $a = 6/2 = 3$ and so the impedance reflected into the primary circuit is $3^2(2\angle-45^\circ) = 18\angle-45^\circ\ \Omega$. Thus,

$$I_1 = \frac{240\angle 20^\circ}{14\angle 30^\circ + 18\angle -45^\circ} = \frac{240\angle 20^\circ}{25.5\angle -13^\circ} = 9.41\angle 33^\circ \text{ A}$$

If the upper primary terminal is dotted, the bottom secondary terminal should be dotted. Then both I_1 and I_2 will be referenced into dots, and so I_2 is equal to the negative of the turns ratio times I_1 :

$$I_2 = -3I_1 = -3(9.41\angle 33^\circ) = -28.2\angle 33^\circ \text{ A}$$

16.15 Find I_1 and I_2 for the circuit shown in Fig. 16-15a.

The $1\text{-}\Omega$ resistance and the $j2\text{-}\Omega$ inductive impedance in the secondary circuit reflect into the primary circuit as $3^2(1) = 9\ \Omega$ and $3^2(j2) = j18\ \Omega$ in series with the $6\text{-}\Omega$ resistance, as shown in Fig. 16-15b. In

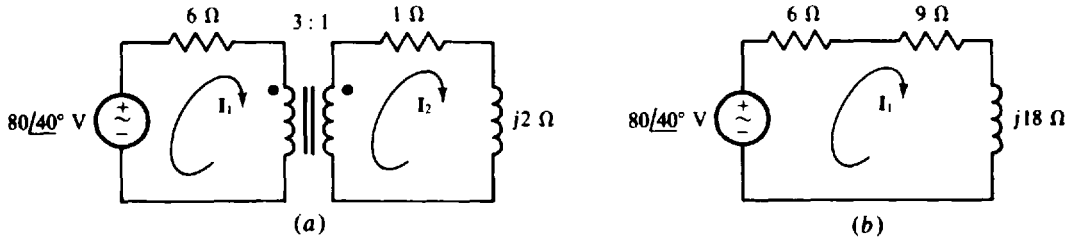

Fig. 16-15

effect, these reflected elements replace the primary winding. From the simplified circuit, the primary current is

$$I_1 = \frac{80\angle 40^\circ}{6 + 9 + j18} = \frac{80\angle 40^\circ}{23.43\angle 50.2^\circ} = 3.41\angle -10.2^\circ \text{ A}$$

Because I_1 is referenced into a dotted terminal and I_2 is referenced out of a dotted terminal, I_2 is equal to just the turns ratio times I_1 (no negative sign):

$$I_2 = 3I_1 = 3(3.41\angle -10.2^\circ) = 10.2\angle -10.2^\circ \text{ A}$$

16.16 Find I_1 , I_2 , and I_3 for the circuit shown in Fig. 16-16a.

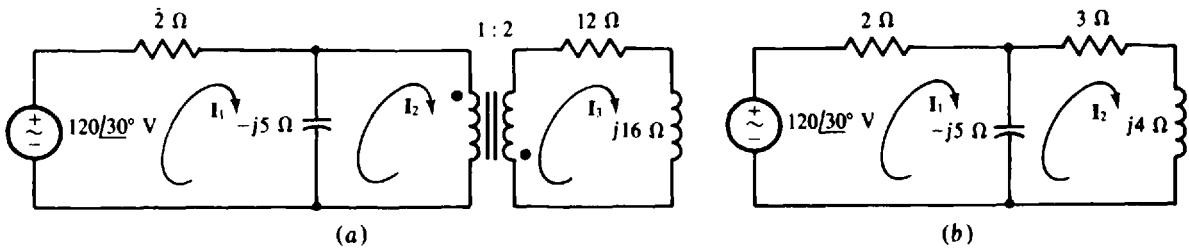

Fig. 16-16

The 12-Ω resistance and the $j16\text{-}\Omega$ inductive impedance reflect into the primary circuit as a $(1/2)^2(12) = 3\text{-}\Omega$ resistance and a series $(1/2)^2(j16) = j4\text{-}\Omega$ inductive impedance in parallel with the $-j5\text{-}\Omega$ capacitive impedance, as shown in Fig. 16-16b. The impedance of the parallel combination is

$$\frac{-j5(3 + j4)}{-j5 + 3 + j4} = \frac{20 - j15}{3 - j1} = 7.91\angle -18.4^\circ \Omega$$

So,
$$I_1 = \frac{120\angle 30^\circ}{2 + 7.91\angle -18.4^\circ} = 12.2\angle 44.7^\circ \text{ A}$$

By current division,
$$I_2 = \frac{-j5}{3 + j4 - j5} \times 12.2\angle 44.7^\circ = 19.3\angle -26.8^\circ \text{ A}$$

Finally, since I_2 and I_3 both have reference directions into dotted terminals, I_3 is equal to the negative of the turns ratio times I_2 :

$$I_3 = -0.5(19.3\angle -26.8^\circ) = -9.66\angle -26.8^\circ \text{ A}$$

16.17 Find V for the circuit shown in Fig. 16-17a.

Although reflection can be used, a circuit must be reflected instead of just an impedance because each circuit has a voltage source. And, because a voltage in the secondary circuit is desired, it is slightly preferable to reflect the primary circuit into the secondary. Of course, each reflected impedance is $(1/a)^2$ times the

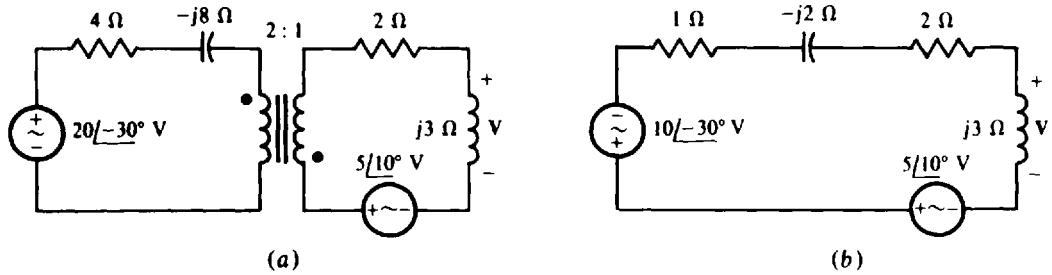

Fig. 16-17

original impedance, and the voltage of the reflected voltage source is $1/a$ times the original voltage. Also, the polarity of the reflected voltage source is reversed because the dots are located at opposite ends of the windings. The result is shown in Fig. 16-17b. By voltage division,

$$V = \frac{j3}{1 - j2 + 2 + j3} \times (5\angle 10^\circ - 10\angle -30^\circ) = \frac{20.9\angle 212^\circ}{3.16\angle 18^\circ} = 6.6\angle 194^\circ = -6.6\angle 14^\circ \text{ V}$$

16.18 Use PSpice to determine V in the circuit of Fig. 16-17a of Prob. 16.17.

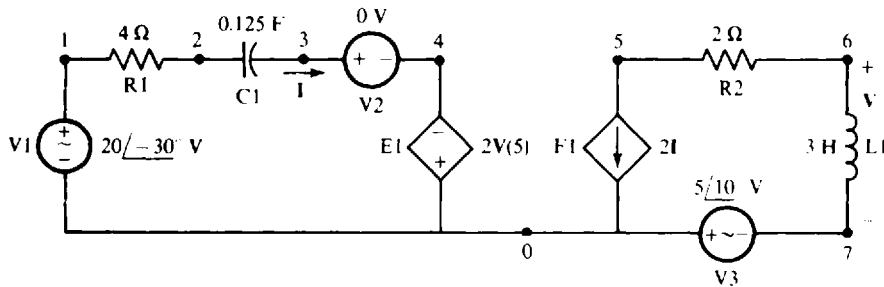

Fig. 16-18

Figure 16-18 shows the corresponding PSpice circuit for a frequency of $\omega = 1$ rad/s. Following is the circuit file and the answers obtained from the output file when this circuit file is run with PSpice. The answer of $V = 6.6\angle -166^\circ = -6.6\angle 14^\circ \text{ V}$ agrees with the answer obtained in the solution to Prob. 16.17.

CIRCUIT FILE FOR THE CIRCUIT OF FIG. 16-18

```
V1 1 0 AC 20 -30
R1 1 2 4
C1 2 3 0.125
V2 3 4
E1 0 4 5 0 2
F1 5 0 V2 2
R2 5 6 2
L1 6 7 3
V3 0 7 AC 5 10
.AC LIN 1 0.159155 0.159155
.PRINT AC VM(L1) VP(L1)
.END
```

FREQ	VM(L1)	VP(L1)
1.592E-01	6.600E+00	-1.660E+02

16.19 Find I_1 and I_2 in the circuit of Fig. 16-19.

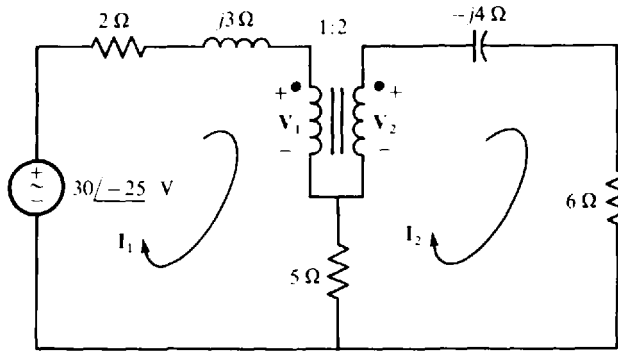

Fig. 16-19

Because the 5-Ω resistor directly couples both halves of the circuit, the reflection approach cannot be used. However, two mesh equations can be written, and then these equations augmented with the voltage and current transformer equations to obtain four equations in terms of four unknowns:

$$\begin{aligned} (7 + j3)I_1 - 5I_2 + V_1 &= 30\angle -25^\circ \\ -5I_1 + (11 - j4)I_2 - V_2 &= 0 \\ -2V_1 + V_2 &= 0 \\ I_1 - 2I_2 &= 0 \end{aligned}$$

In matrix form, these equations are

$$\begin{bmatrix} 7 + j3 & -5 & 1 & 0 \\ -5 & 11 - j4 & 0 & -1 \\ 0 & 0 & -2 & 1 \\ 1 & -2 & 0 & 0 \end{bmatrix} \begin{bmatrix} I_1 \\ I_2 \\ V_1 \\ V_2 \end{bmatrix} = \begin{bmatrix} 30\angle -25^\circ \\ 0 \\ 0 \\ 0 \end{bmatrix}$$

A scientific calculator can be used to solve for I_1 and I_2 . The results are $I_1 = 5.821\angle -47.83^\circ$ A and $I_2 = 2.910\angle -47.83^\circ$ A.

16.20 Repeat Prob. 16.19 using PSpice.

Figure 16-20 is the PSpice circuit corresponding to the circuit of Fig. 16-19, with the inductor and capacitor values based on a frequency of $\omega = 1$ rad/s. Resistor R4 is inserted to prevent a capacitor (C1)

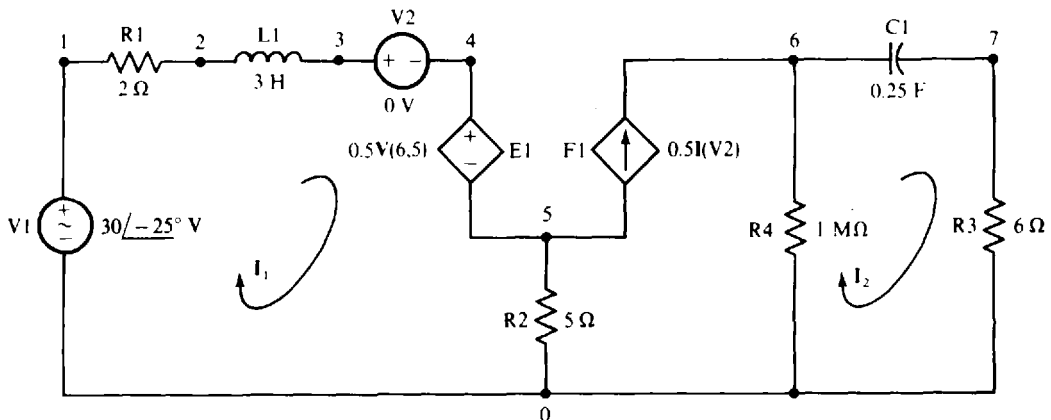

Fig. 16-20

from being in series with a current source (F1), since PSpice does not allow this. But the resistance of R4 is so large that the presence of this resistor will not significantly affect the answer. Dummy voltage source V2 is inserted, of course, to sense the controlling current for dependent current source F1.

Following is the corresponding circuit file along with the answers obtained from the output file when the circuit file is run with PSpice. The answers of $I_1 = 5.821/-47.83$ A and $I_2 = 2.910/-47.83$ A agree with the answers obtained in the solution to Prob. 16.19.

```

CIRCUIT FILE FOR THE CIRCUIT OF FIG. 16-20
V1 1 0 AC 30 -25
R1 1 2 2
L1 2 3 3
V2 3 4
E1 4 5 6 5 0.5
R2 5 0 5
F1 5 6 V2 0.5
C1 6 7 0.25
R3 7 0 6
R4 6 0 1MEG
.AC LIN 1 0.159155 0.159155
.PRINT AC IM(R1) IP(R1) IM(R3) IP(R3)
.END

FREQ          IM(R1)          IP(R1)          IM(R3)          IP(R3)
1.592E-01    5.821E+00     -4.783E+01     2.910E+00     -4.783E+01

```

16.21 Determine the branch currents I_1 , I_2 , and I_3 in the circuit of Fig. 16-21.

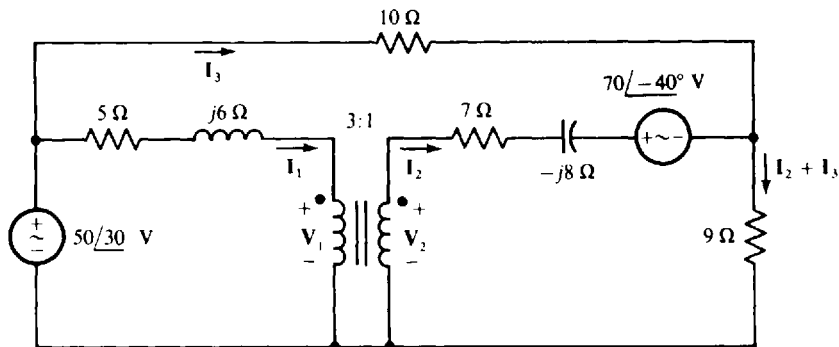

Fig. 16-21

Reflection cannot be used here because of the presence of the $10\text{-}\Omega$ resistor that along with the common ground provides a current path between the two winding circuits. For reflection to be applicable, the two windings must be only magnetically coupled. KVL can, however, be applied, and is best done around the two winding meshes and the outside loop. The resulting three equations will contain five variables, and must be augmented with the voltage and current transformer equations. These five equations are

$$\begin{aligned}
 (5 + j6)I_1 + V_1 &= 50/30^\circ \\
 -V_2 + (7 - j8)I_2 + 9(I_2 + I_3) &= -70/-40^\circ \\
 10I_3 + 9(I_3 + I_2) &= 50/30^\circ \\
 V_1 - 3V_2 &= 0 \\
 3I_1 - I_2 &= 0
 \end{aligned}$$

In matrix form these are

$$\begin{bmatrix} 5 + j6 & 0 & 0 & 1 & 0 \\ 0 & 16 - j8 & 9 & 0 & -1 \\ 0 & 9 & 19 & 0 & 0 \\ 0 & 0 & 0 & 1 & -3 \\ 3 & -1 & 0 & 0 & 0 \end{bmatrix} \begin{bmatrix} I_1 \\ I_2 \\ I_3 \\ V_1 \\ V_2 \end{bmatrix} = \begin{bmatrix} 50/30 \\ -70/-40 \\ 50/30 \\ 0 \\ 0 \end{bmatrix}$$

If a scientific calculator is used to obtain solutions, the results are $I_1 = 1.693/176.0^\circ$ A, $I_2 = 5.079/176.0^\circ$ A, and $I_3 = 4.818/13.80^\circ$ A.

16.22 Repeat Prob. 16.21 using PSpice.

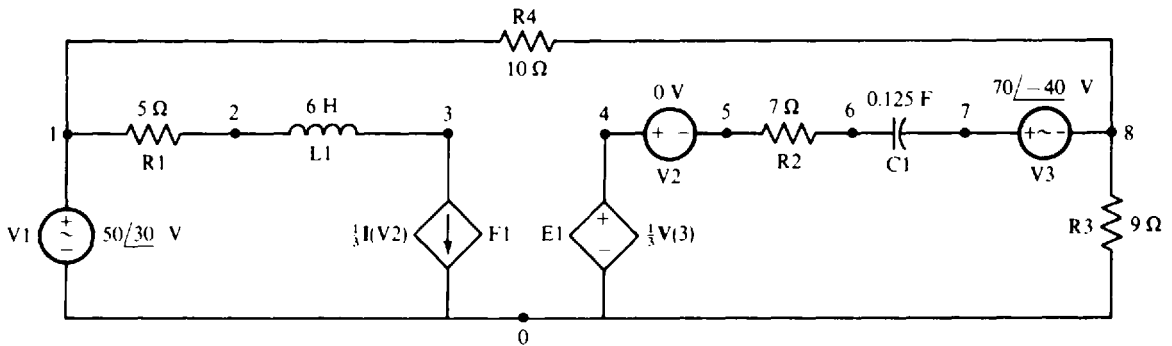

Fig. 16-22

Figure 16-22 shows the PSpice circuit corresponding to the circuit of Fig. 16-21. The inductor and capacitor values are based on a frequency of $\omega = 1$ rad/s. A dummy voltage source V2 has been inserted to sense the controlling current for the dependent current source F1. Following is the corresponding circuit file along with the answers obtained from the output file when this circuit file is run with PSpice. The answers agree with those obtained in the solution to Prob. 16.21.

CIRCUIT FILE FOR THE CIRCUIT OF FIG. 16-22

```
V1 1 0 AC 50 30
R1 1 2 5
L1 2 3 6
F1 3 0 V2 0.333333
E1 4 0 3 0 0.333333
V2 4 5
R2 5 6 7
C1 6 7 0.125
V3 7 8 AC 70 -40
R3 8 0 9
R4 1 8 10
.AC LIN 1 0.159155 0.159155
.PRINT AC IM(R1) IP(R1) IM(R2) IP(R2) IM(R4) IP(R4)
.END
```

FREQ	IM(R1)	IP(R1)	IM(R2)	IP(R2)	IM(R4)
1.592E-01	1.693E+00	1.760E+02	5.079E+00	1.760E+02	4.818E+00
FREQ	IP(R4)				
1.592E-01	1.380E+01				

- 16.23** An air-core transformer has primary and secondary currents of $i_1 = 0.2$ A and $i_2 = 0.4$ A that produce fluxes of $\phi_{m1} = 100 \mu\text{Wb}$, $\phi_{l1} = 250 \mu\text{Wb}$, and $\phi_{l2} = 300 \mu\text{Wb}$. Find ϕ_{m2} , M , L_1 , L_2 , and k if $N_1 = 25$ turns and $N_2 = 40$ turns.

By the mutual inductance formulas,

$$M = \frac{N_1 \phi_{m2}}{i_2} = \frac{N_2 \phi_{m1}}{i_1} \quad \text{from which} \quad \phi_{m2} = \frac{i_2 N_2 \phi_{m1}}{N_1 i_1} = \frac{0.4(40)(100)}{25(0.2)} = 320 \mu\text{Wb}$$

$$\text{Also} \quad M = \frac{N_1 \phi_{m2}}{i_2} = \frac{25(320 \times 10^{-6})}{0.4} = 20 \text{ mH}$$

From the self-inductance formulas,

$$L_1 = \frac{N_1(\phi_{m1} + \phi_{l1})}{i_1} = \frac{25(100 \times 10^{-6} + 250 \times 10^{-6})}{0.2} = 43.8 \text{ mH}$$

$$\text{and} \quad L_2 = \frac{N_2(\phi_{m2} + \phi_{l2})}{i_2} = \frac{40(320 \times 10^{-6} + 300 \times 10^{-6})}{0.4} = 62 \text{ mH}$$

The coefficient of coupling is

$$k = \sqrt{\frac{\phi_{m1}}{\phi_{l1} + \phi_{m1}} \times \frac{\phi_{m2}}{\phi_{l2} + \phi_{m2}}} = \sqrt{\frac{100 \times 10^{-6}}{250 \times 10^{-6} + 100 \times 10^{-6}} \times \frac{320 \times 10^{-6}}{300 \times 10^{-6} + 320 \times 10^{-6}}} = 0.384$$

$$\text{Alternatively,} \quad k = \frac{M}{\sqrt{L_1 L_2}} = \frac{20 \times 10^{-3}}{\sqrt{(43.8 \times 10^{-3})(62 \times 10^{-3})}} = 0.384$$

- 16.24** What is the greatest mutual inductance that an air-core transformer can have if its self-inductances are 0.3 and 0.7 H?

From $k = M/\sqrt{L_1 L_2}$ rearranged to $M = k\sqrt{L_1 L_2}$ and the fact that k has a maximum value of 1, $M_{\max} = \sqrt{0.3(0.7)} = 0.458$ H.

- 16.25** For each of the following, find the missing quantity either self-inductance, mutual inductance, or coefficient of coupling:

(a) $L_1 = 0.3$ H, $L_2 = 0.4$ H, $M = 0.2$ H

(b) $L_1 = 4$ mH, $M = 5$ mH, $k = 0.4$

(c) $L_1 = 30 \mu\text{H}$, $L_2 = 40 \mu\text{H}$, $k = 0.5$

(d) $L_2 = 0.4$ H, $M = 0.2$ H, $k = 0.2$

(a) $k = \frac{M}{\sqrt{L_1 L_2}} = \frac{0.2}{\sqrt{0.3(0.4)}} = 0.577$

(b) $k\sqrt{L_1 L_2} = M$ from which $L_2 = \frac{M^2}{L_1 k^2} = \frac{5^2}{4(0.4)^2} = 39.1$ mH

(c) $M = k\sqrt{L_1 L_2} = 0.5\sqrt{30(40)} = 17.3 \mu\text{H}$

(d) $L_1 = \frac{M^2}{L_2 k^2} = \frac{0.2^2}{0.4(0.2)^2} = 2.5$ H

- 16.26** An air-core transformer has an open-circuited secondary winding with 50 V across it when the primary current is 30 mA at 3 kHz. If the primary self-inductance is 0.3 H, find the primary voltage and the mutual inductance.

Since phasors are not specified or mentioned, presumably the electric quantities specified and wanted are rms. Because the secondary is open-circuited, $I_2 = 0$ A, which means that $\omega MI_2 = 0$ and $\omega L_2 I_2 = 0$ in the voltage equations. So, the rms primary voltage is

$$V_1 = \omega L_1 I_1 = 2\pi(3000)(0.3)(30 \times 10^{-3}) = 170 \text{ V}$$

Also, the secondary voltage equation is $V_2 = \omega MI_1$, from which

$$M = \frac{V_2}{\omega I_1} = \frac{50}{2\pi(3000)(30 \times 10^{-3})} = 88.4 \text{ mH}$$

- 16.27** An air-core transformer has an open-circuited secondary with 80 V across it when the primary carries a current of 0.4 A and has a voltage of 120 V at 60 Hz. What are the primary self-inductance and also the mutual inductance?

Because the secondary is open-circuited, there is no current in this winding and so no mutually induced voltage in the primary winding. As a consequence, the rms voltage and current of the primary are related by the primary winding reactance: $\omega L_1 = V_1/I_1$, from which

$$L_1 = \frac{V_1}{\omega I_1} = \frac{120}{2\pi(60)(0.4)} = 0.796 \text{ H}$$

With the open-circuited secondary carrying zero current, the voltage of this winding is solely the mutually induced voltage: $V_2 = \omega MI_1$, from which

$$M = \frac{V_2}{\omega I_1} = \frac{80}{2\pi(60)(0.4)} = 0.531 \text{ H}$$

- 16.28** Find the voltage across the open-circuited secondary of an air-core transformer when 35 V at 400 Hz is applied to the primary. The transformer inductances are $L_1 = 0.75$ H, $L_2 = 0.83$ H, and $M = 0.47$ H.

Because the secondary is open-circuited, $I_2 = 0$ A, which means that the rms primary voltage is $V_1 = \omega L_1 I_1$ and the rms secondary voltage is $V_2 = \omega MI_1$. The ratio of these equations is

$$\frac{V_2}{V_1} = \frac{\omega MI_1}{\omega L_1 I_1} \quad \text{from which} \quad V_2 = \frac{MV_1}{L_1} = \frac{0.47(35)}{0.75} = 21.9 \text{ V}$$

- 16.29** An air-core transformer with an open-circuited secondary has inductances of $L_1 = 20$ mH, $L_2 = 32$ mH, and $M = 13$ mH. Find the primary and secondary voltages when the primary current is increasing at the rate of 0.4 kA/s.

With the assumption of associated references,

$$v_1 = L_1 \frac{di_1}{dt} \pm M \frac{di_2}{dt} \quad \text{and} \quad v_2 = L_2 \frac{di_2}{dt} \pm M \frac{di_1}{dt}$$

In the first equation, di_2/dt is zero because of the open circuit, and di_1/dt is the specified 0.4 kA/s. So, $v_1 = (20 \times 10^{-3})(0.4 \times 10^3) = 8$ V. Similarly, the secondary voltage is $v_2 = \pm M di_1/dt = \pm(13 \times 10^{-3})(0.4 \times 10^3) = \pm 5.2$ V. Since the reference for v_2 is not specified, the sign of v_2 cannot be determined.

- 16.30** A transformer with a short-circuited secondary has inductances of $L_1 = 0.3$ H, $L_2 = 0.4$ H, and $M = 0.2$ H. Find the short-circuit secondary current I_2 when the primary current is $I_1 = 0.5$ A at 60 Hz.

Because of the short circuit,

$$V_2 = j\omega L_2 I_2 \pm j\omega M I_1 = 0 \quad \text{from which} \quad j\omega L_2 I_2 = \pm j\omega M I_1 \quad \text{and} \quad L_2 I_2 = \pm M I_1$$

Since only rms quantities are of interest, as must be assumed from the problem specification, the angles of I_1 and I_2 can be neglected and the \pm sign of \pm used, giving $L_2 I_2 = M I_1$. From this, the short-circuit secondary current I_2 is

$$I_2 = \frac{M I_1}{L_2} = \frac{0.2(0.5)}{0.4} = 0.25 \text{ A}$$

The same result would have been obtained by dividing $\omega M I_1$, the rms induced generator voltage, by ωL_2 , the reactance that the short-circuit secondary current I_2 flows through.

- 16.31** When connected in series, two windings of an air-core transformer have a total inductance of 0.4 H. With the reversal of the connections to one winding, though, the total inductance is 0.8 H. Find the mutual inductance of the transformer.

Because the windings are in series, the same current i flows through them during the inductance measurement, producing a voltage drop of $L_1 di/dt \pm M di/dt = (L_1 \pm M) di/dt$ in one winding and a voltage drop of $L_2 di/dt \pm M di/dt = (L_2 \pm M) di/dt$ in the other. If the windings are arranged such that i flows into the dotted terminal of one winding but out of the dotted terminal of the other, both mutual terms are negative. But if i flows into both dotted terminals or out of them, both mutual terms are positive. Since the $M di/dt$ terms have the same sign, either both positive or both negative, the total voltage drop is $(L_1 + L_2 \pm 2M) di/dt$. The $L_1 + L_2 \pm 2M$ coefficient of di/dt is the total inductance. Obviously, the larger measured inductance must be for the positive sign, $L_1 + L_2 + 2M = 0.8$ H, and the smaller measured inductance must be for the negative sign, $L_1 + L_2 - 2M = 0.4$ H. If the second equation is subtracted from the first, the result is

$$L_1 + L_2 + 2M - (L_1 + L_2 - 2M) = 0.8 - 0.4 = 0.4$$

from which $4M = 0.4$ and $M = 0.1$ H.

Consequently, a method for finding the mutual inductance of an air-core transformer is to connect the two windings in series and measure the total inductance, then reverse one winding connection and measure the total inductance. The mutual inductance is one-fourth of the difference of the larger measurement minus the smaller measurement. Obviously, the self-inductance of a winding can be measured directly if the other winding is open-circuited.

- 16.32** An air-core transformer has 3-mH mutual inductance and a 5-mH secondary self-inductance. A 5- Ω resistor and a 100- μ F capacitor are in series with the secondary winding. Find the impedance coupled into the primary for $\omega = 1$ krad/s.

The coupled impedance is $(\omega M)^2 Z_2$, where Z_2 is the total impedance of the secondary circuit. Here, $\omega M = 10^3(3 \times 10^{-3}) = 3 \Omega$ and

$$Z_2 = R + j\omega L + \frac{-j1}{\omega C} = 5 + j10^3(5 \times 10^{-3}) + \frac{-j1}{10^3(100 \times 10^{-6})} = 5 + j5 - j10 = 5 - j5 = 7.07 \angle -45^\circ \Omega$$

and so the coupled impedance is

$$\frac{(\omega M)^2}{Z_2} = \frac{3^2}{7.07 \angle -45^\circ} = 1.27 \angle 45^\circ \Omega$$

Notice that the capacitive secondary impedance couples into the primary circuit as an inductive impedance. This change in the nature of the impedance always occurs on coupling because the secondary circuit impedance is in the denominator of the coupling impedance formula. In contrast, there is no such change in reflected impedance with an ideal transformer.

16.33 A 1-kΩ resistor is connected across the secondary of a transformer for which $L_1 = 0.1$ H, $L_2 = 2$ H, and $k = 0.5$. Find the resistor voltage when 250 V at 400 Hz is applied to the primary.

A good approach is to first find ωMI_1 , which is the induced mutual secondary voltage, and then use it to find the voltage across the 1-kΩ resistor. Since both M and I_1 in ωMI_1 are unknown, they must be found. The mutual inductance M is

$$M = k\sqrt{L_1 L_2} = 0.5\sqrt{0.1(2)} = 0.224 \text{ H}$$

With M known, the coupled impedance can be used to obtain I_1 . This impedance is

$$\frac{\omega^2 M^2}{R_2 + j\omega L_2} = \frac{(2\pi \times 400)^2 (0.224)^2}{1000 + j(2\pi \times 400)(2)} = 61.6 \angle -78.7^\circ \Omega$$

The current I_1 is equal to the applied primary voltage divided by the magnitude of the sum of the coupled impedance and the primary winding impedance:

$$I_1 = \frac{250}{|j(2\pi \times 400)(0.1) + 61.6 \angle -78.7^\circ|} = \frac{250}{191} = 1.31 \text{ A}$$

Now, with M and I_1 known, the induced secondary voltage ωMI_1 can be found:

$$\omega MI_1 = (2\pi \times 400)(0.224)(1.31) = 735 \text{ V}$$

Voltage division can be used to find the desired voltage V_2 from this induced voltage. The voltage V_2 is equal to this induced voltage times the quotient of the load resistance and the magnitude of the total impedance of the secondary circuit:

$$V_2 = 735 \frac{1000}{|1000 + j2\pi(400)(2)|} = \frac{735 \times 10^3}{5.13 \times 10^3} = 143 \text{ V}$$

16.34 Find v for the circuit shown in Fig. 16-23a.

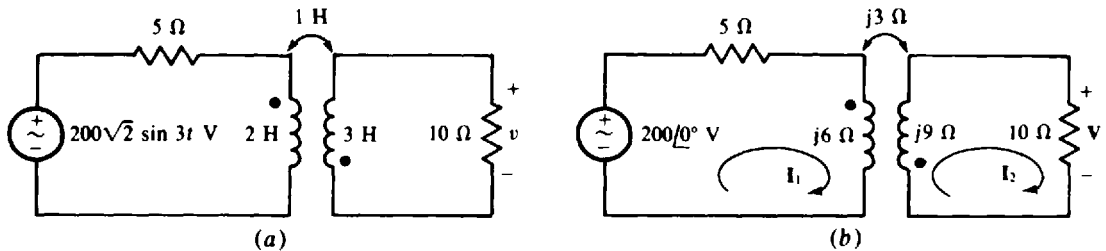

Fig. 16-23

The first step is the construction of the phasor-domain circuit shown in Fig. 16-23b. Next, the mesh equations are written:

$$\begin{aligned} (5 + j6)\mathbf{I}_1 + j3\mathbf{I}_2 &= 200 \\ j3\mathbf{I}_1 + (10 + j9)\mathbf{I}_2 &= 0 \end{aligned}$$

Notice that the mutual terms are positive because both \mathbf{I}_1 and \mathbf{I}_2 have reference directions into dotted terminals. By Cramer's rule,

$$\mathbf{I}_2 = \frac{\begin{vmatrix} 5 + j6 & 200 \\ j3 & 0 \end{vmatrix}}{\begin{vmatrix} 5 + j6 & j3 \\ j3 & 10 + j9 \end{vmatrix}} = \frac{-j3(200)}{(5 + j6)(10 + j9) - (j3)^2} = \frac{600 \angle -90^\circ}{5 + j105} = \frac{600 \angle -90^\circ}{105 \angle 87.3^\circ} = 5.71 \angle -177.3^\circ \text{ A}$$

And $\mathbf{V} = 10\mathbf{I}_2 = 57.1 \angle -177.3^\circ \text{ V}$. The corresponding voltage is

$$v = 57.1\sqrt{2} \sin(3t - 177.3^\circ) = -80.7 \sin(3t + 2.7^\circ) \text{ V}$$

16.35 Find \mathbf{I}_2 for the circuit shown in Fig. 16-24.

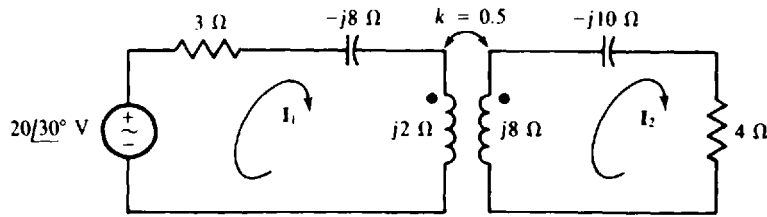

Fig. 16-24

Before mesh equations can be written, the magnitude ωM of $j\omega M$ must be determined. From multiplying both sides of $M = k\sqrt{L_1 L_2}$ by ω ,

$$\omega M = k\sqrt{(\omega L_1)(\omega L_2)} = 0.5\sqrt{2(8)} = 2 \Omega$$

Now the mesh equations can be written:

$$\begin{aligned} (3 - j8 + j2)\mathbf{I}_1 - j2\mathbf{I}_2 &= 20\angle 30^\circ \\ -j2\mathbf{I}_1 + (4 + j8 - j10)\mathbf{I}_2 &= 0 \end{aligned}$$

Notice that the mutual voltage terms have an opposite sign (negative) from that (positive) of the self-induced voltage terms because one current reference direction is into a dotted terminal and the other one is not. In matrix form, these equations are

$$\begin{bmatrix} 3 - j6 & -j2 \\ -j2 & 4 - j2 \end{bmatrix} \begin{bmatrix} \mathbf{I}_1 \\ \mathbf{I}_2 \end{bmatrix} = \begin{bmatrix} 20\angle 30^\circ \\ 0 \end{bmatrix}$$

from which $\mathbf{I}_2 = 1.32\angle -157.6^\circ = -1.32\angle 22.4^\circ \text{ A}$ can be obtained by using a scientific calculator.

16.36 What is the total inductance of an air-core transformer with its windings connected in parallel if both dots are at the same end and if the mutual inductance is 0.1 H and the self-inductances are 0.2 and 0.4 H?

Because of the mutual-inductance effects, it is not possible to simply combine inductances. Instead, a source must be applied and the total inductance found from the ratio of the source voltage to source current, which ratio is the input impedance. Of course a phasor-domain circuit will have to be used. For this circuit the most convenient frequency is $\omega = 1 \text{ rad/s}$, and the most convenient source is $\mathbf{I}_s = 1\angle 0^\circ \text{ A}$. The circuit is shown in Fig. 16-25. The transformer impedances should be obvious from the specified inductances and the radian frequency of $\omega = 1 \text{ rad/s}$. As shown, \mathbf{I}_1 of the $1\angle 0^\circ \text{ A}$ input current flows through the left-hand winding, leaving a current of $1\angle 0^\circ - \mathbf{I}_1$ for the right-hand winding.

The voltage drops across the windings are

$$\mathbf{V} = j0.2\mathbf{I}_1 + j0.1(1\angle 0^\circ - \mathbf{I}_1) \quad \text{and} \quad \mathbf{V} = j0.1\mathbf{I}_1 + j0.4(1\angle 0^\circ - \mathbf{I}_1).$$

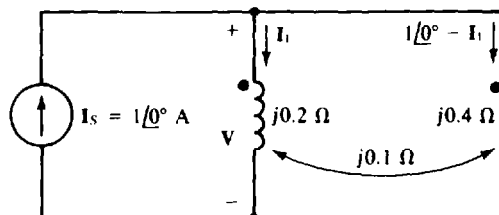

Fig. 16-25

The mutual voltage terms have the same signs as the self-induced voltage terms because both current reference directions are into dotted ends. Upon rearrangement and simplification, these equations become

$$-j0.1\mathbf{I}_1 + \mathbf{V} = j0.1 \quad \text{and} \quad j0.3\mathbf{I}_1 + \mathbf{V} = j0.4.$$

The unknown \mathbf{I}_1 can be eliminated by multiplying the first equation by 3 and adding corresponding sides of the equations. The result is

$$3\mathbf{V} + \mathbf{V} = j0.3 + j0.4 \quad \text{from which} \quad \mathbf{V} = \frac{j0.7}{4} = j0.175 \text{ V}$$

But
$$j\omega L_T = \frac{\mathbf{V}}{\mathbf{I}_s} = \frac{j0.175}{1/\underline{0^\circ}} = j0.175 \Omega$$

Finally, since $\omega = 1 \text{ rad/s}$, the total inductance is $L_T = 0.175 \text{ H}$.

16.37 Find i_2 for the circuit shown in Fig. 16-26a.

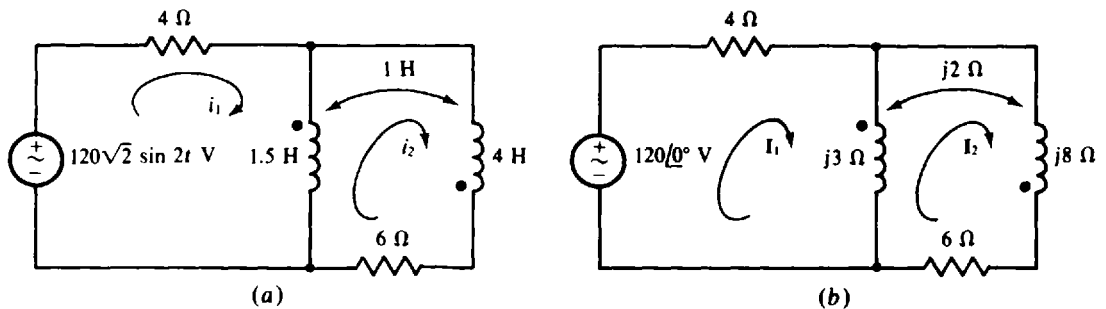

Fig. 16-26

The first step is the construction of the phasor-domain circuit shown in Fig. 16-26b, from which mesh equations can be written. These are

$$\begin{aligned} (4 + j3)\mathbf{I}_1 - j3\mathbf{I}_2 - j2\mathbf{I}_2 &= 120\angle 0^\circ \\ -j3\mathbf{I}_1 - j2\mathbf{I}_1 + [j3 + j8 + 6 + 2(j2)]\mathbf{I}_2 &= 0 \end{aligned}$$

In the first equation, the $4 + j3$ coefficient of \mathbf{I}_1 is, of course, the self-impedance of mesh 1, and the $-j3$ coefficient of \mathbf{I}_2 is the negative of the mutual impedance. The $-j2\mathbf{I}_2$ term is the voltage induced in the left-hand winding by \mathbf{I}_2 flowing in the right-hand winding. This term is negative because \mathbf{I}_1 enters a dotted terminal but \mathbf{I}_2 does not. In the second equation, the $-j3\mathbf{I}_1$ term is the mutual-impedance voltage, and $-j2\mathbf{I}_1$ is the voltage induced in the right-hand winding by \mathbf{I}_1 flowing in the left-hand winding. This term is negative for the same reason that $-j2\mathbf{I}_2$ is negative in the first equation, as has been explained. The $j3 + j8 + 6$ part of the coefficient of \mathbf{I}_2 is the self-impedance of mesh 2. The $2(j2)$ part of this coefficient is from a voltage $j2\mathbf{I}_2$ induced in each winding by \mathbf{I}_2 flowing in the other winding. It is positive because \mathbf{I}_2 enters undotted terminals of both windings.

These equations simplify to

$$\begin{aligned} (4 + j3)\mathbf{I}_1 - j5\mathbf{I}_2 &= 120 \\ -j5\mathbf{I}_1 + (6 + j15)\mathbf{I}_2 &= 0 \end{aligned}$$

By Cramer's rule,

$$\mathbf{I}_2 = \frac{\begin{vmatrix} 4 + j3 & 120 \\ -j5 & 0 \end{vmatrix}}{\begin{vmatrix} 4 + j3 & -j5 \\ -j5 & 6 + j15 \end{vmatrix}} = \frac{-(-j5)(120)}{(4 + j3)(6 + j15) - (-j5)^2} = \frac{j600}{4 + j78} = 7.68\angle 2.94^\circ \text{ A}$$

The corresponding current is

$$i_2 = 7.68\sqrt{2} \sin(2t + 2.94) = 10.9 \sin(2t + 2.94) \text{ A}$$

- 16.38** Find V for the circuit shown in Fig. 16-27. Then replace the $15\text{-}\Omega$ resistor with an open circuit and find V again.

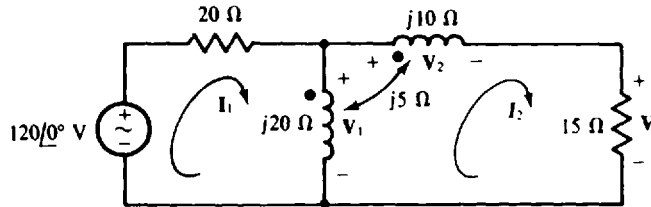

Fig. 16-27

The mesh equations are

$$\begin{aligned} (20 + j20)I_1 - j20I_2 + j5I_2 &= 120/0 \\ -j20I_1 + j5I_1 + [j20 + j10 + 15 - 2(j5)]I_2 &= 0 \end{aligned}$$

All the terms should be apparent except, perhaps, those for the mutually induced voltages. The $j5I_2$ in the first equation is the voltage induced in the vertical winding by I_2 flowing in the horizontal winding. It is positive because both I_1 and I_2 enter dotted terminals. The $j5I_1$ term in the second equation is the voltage induced in the horizontal winding by I_1 flowing in the vertical winding. It is positive for the same reason that $j5I_2$ is positive in the first equation. The $-2(j5)I_2$ term is the result of a voltage of $j5I_2$ induced in each winding by I_2 flowing in the other winding. It is negative because I_2 enters a dotted terminal of one winding, but not of the other. These equations simplify to

$$\begin{aligned} (20 + j20)I_1 - j15I_2 &= 120 \\ -j15I_1 + (15 + j20)I_2 &= 0 \end{aligned}$$

from which

$$I_2 = \frac{\begin{vmatrix} 20 + j20 & 120 \\ -j15 & 0 \end{vmatrix}}{\begin{vmatrix} 20 + j20 & -j15 \\ -j15 & 15 + j20 \end{vmatrix}} = \frac{-(-j15)(120)}{(20 + j20)(15 + j20) - (-j15)^2} = \frac{j1800}{125 + j700} = 2.53/10.1 \text{ A}$$

Finally,
$$V = 15I_2 = 15(2.53/10.1) = 38/10.1 \text{ V}$$

If the $15\text{-}\Omega$ resistor is removed, then $I_2 = 0 \text{ A}$ and V is equal to the sum of the voltage drops across the two windings. The only current that flows is I_1 , which is

$$I_1 = \frac{120/0}{20 + j20} = 4.24/-45 \text{ A}$$

Across the vertical winding, I_1 produces a self-inductive voltage drop of

$$V_1 = j20I_1 = j20(4.24/-45) = 84.8/45 \text{ V}$$

referenced positive on the dotted end. Across the horizontal winding, I_1 produces a mutually induced voltage of

$$V_2 = j5I_1 = j5(4.24/-45) = 21.2/45 \text{ V}$$

Like the other induced voltage, it also has a positive reference on a dotted end since part of the same flux produces it. (Actually, a changing flux produces the corresponding voltages v_1 and v_2 .) Finally, since the dotted ends of the two windings are adjacent, V is equal to the difference in the two winding voltages:

$$V = V_1 - V_2 = 84.8/45 - 21.2/45 = 63.6/45 \text{ V}$$

16.39 Repeat the first part of Prob. 16.38 using PSpice.

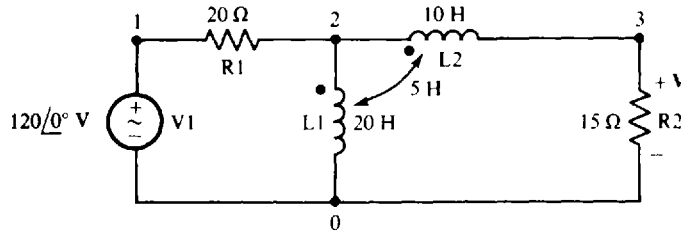

Fig. 16-28

Figure 16-28 shows the PSpice circuit corresponding to the phasor-domain circuit of Fig. 16-27. The inductance values are based on a frequency of $\omega = 1 \text{ rad/s}$, which is selected for convenience. The coefficient of coupling needed for the circuit file is $k = M/\sqrt{L_1 L_2} = 5/\sqrt{20 \times 10} = 0.353553$.

Following is the corresponding circuit file along with the answer from the output file obtained when PSpice is run with this circuit file. The answer of $V = 37.97/10.12 \text{ V}$ agrees to three significant digits with the first answer of Prob. 16.38.

CIRCUIT FILE FOR THE CIRCUIT OF FIG. 16-28

```
V1 1 0 AC 120
R1 1 2 20
L1 2 0 20
L2 2 3 10
K1 L1 L2 0.353553
R2 3 0 15
.AC LIN 1 0.159155 0.159155
.PRINT AC VM(R2) VP(R2)
.END
```

FREQ	VM(R2)	VP(R2)
1.592E-01	3.797E+01	1.012E+01

16.40 Determine the mesh currents in the circuit of Fig. 16-29.

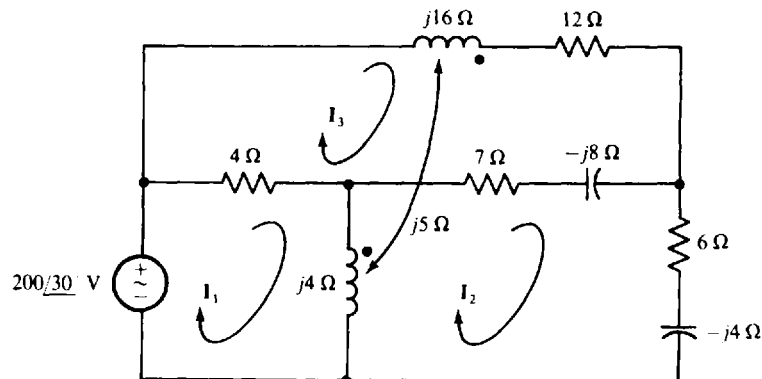

Fig. 16-29

The mesh equations are

$$\begin{aligned}(4 + j4)\mathbf{I}_1 - j4\mathbf{I}_2 - 4\mathbf{I}_3 &= 200/30 \\ -j4\mathbf{I}_1 + (j4 + 7 - j8 + 6 - j4)\mathbf{I}_2 - (7 - j8)\mathbf{I}_3 + j5\mathbf{I}_3 &= 0 \\ -4\mathbf{I}_1 - (7 - j8)\mathbf{I}_2 + (4 + j16 + 12 - j8 + 7)\mathbf{I}_3 + j5(\mathbf{I}_2 - \mathbf{I}_1) &= 0\end{aligned}$$

In the \mathbf{I}_1 mesh equation, the mutual term $-j5\mathbf{I}_3$ has a negative sign because \mathbf{I}_1 is directed into a dotted end of a transformer winding but \mathbf{I}_3 is not. In the \mathbf{I}_2 mesh equation, the mutual term $j5\mathbf{I}_3$ does not have a negative sign because both \mathbf{I}_2 and \mathbf{I}_3 have directions into undotted ends of the transformer windings. And in the \mathbf{I}_3 mesh equation, the mutual term is $j5(\mathbf{I}_2 - \mathbf{I}_1)$ because both \mathbf{I}_2 and \mathbf{I}_3 have directions into undotted ends of the transformer windings but \mathbf{I}_1 does not. When simplified and placed in matrix form, these equations are

$$\begin{bmatrix} 4 + j4 & -j4 & -4 - j5 \\ -j4 & 13 - j8 & -7 + j13 \\ -4 - j5 & -7 + j13 & 23 + j8 \end{bmatrix} \begin{bmatrix} \mathbf{I}_1 \\ \mathbf{I}_2 \\ \mathbf{I}_3 \end{bmatrix} = \begin{bmatrix} 200/30 \\ 0 \\ 0 \end{bmatrix}$$

The solutions to these equations can be obtained by using a scientific calculator. They are $\mathbf{I}_1 = 51.37/5.836^\circ$ A, $\mathbf{I}_2 = 10.06/44.79^\circ$ A, and $\mathbf{I}_3 = 16.28/16.87^\circ$ A.

16.41 Repeat Prob. 16.40 using PSpice.

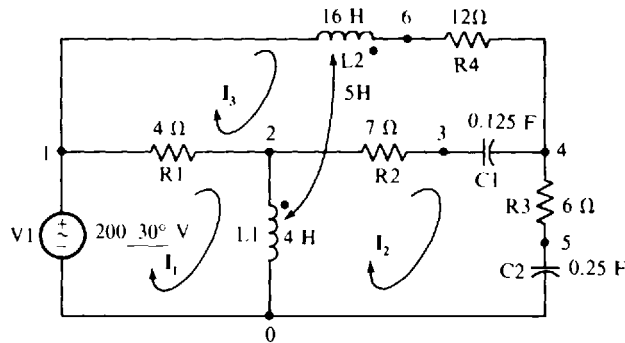

Fig. 16-30

Figure 16-30 shows the PSpice circuit corresponding to the phasor-domain circuit of Fig. 16-29 of Prob. 16.40. As usual, the inductances and capacitances are based on the frequency $\omega = 1$ rad/s. The coefficient of coupling needed for the circuit file is $k = M / \sqrt{L_1 L_2} = 5 / \sqrt{4 \times 16} = 0.625$.

Following is the corresponding circuit file along with the answers from the output file obtained when PSpice is run with this circuit file. The answers agree with those obtained in the solution to Prob. 16.40.

CIRCUIT FILE FOR THE CIRCUIT OF FIG. 16-30

```
V1 0 1 AC -200 30
R1 1 2 4
L1 2 0 4
R2 2 3 7
C1 3 4 0.125
R3 4 5 6
C2 5 0 0.25
L2 6 1 16
K1 L1 L2 0.625
R4 6 4 12
.AC LIN 1 0.159155 0.159155
.PRINT AC IM(V1) IP(V1) IM(R3) IP(R3) IM(R4) IP(R4)
.END
```

FREQ	IM(V1)	IP(V1)	IM(R3)	IP(R3)	IM(R4)
1.592E-01	5.137E+01	5.836E+00	1.006E+01	4.479E+01	1.628E+01
FREQ	IP(R4)				
1.592E-01	1.687E+01				

16.42 What is the turns ratio of a two-winding transformer that can be connected as an autotransformer of 500/350 kV?

As can be seen from Fig. 16-7, the lower voltage is the voltage across one winding, and the higher voltage is the sum of the winding voltages. So, for this transformer, one winding voltage rating is 350 kV and the other is $500 - 350 = 150$ kV. The turns ratio is, of course, equal to the ratio of these ratings: $a = 350/150 = 2.33$ or $a = 150/350 = 0.429$, depending upon which winding is the primary and which is the secondary.

16.43 Compare the winding currents of a fully loaded 277/120-V, 50-kVA two-winding transformer and an autotransformer with the same rating.

The high-voltage winding of the conventional transformer must carry $50\,000/277 = 181$ A, and the low-voltage winding must carry $50\,000/120 = 417$ A. So, one winding carries the source current and the other winding carries the load current. In contrast, and as shown in the circuit of Fig. 16-31, part of the autotransformer winding must carry only the difference in the source and load currents, which is $417 - 181 = 236$ A, as compared to the 417 A that the low-voltage winding of the conventional transformer must carry. Consequently, smaller wire can be used in the autotransformer, which results in a savings in the cost of copper. Also, the autotransformer can be smaller and lighter.

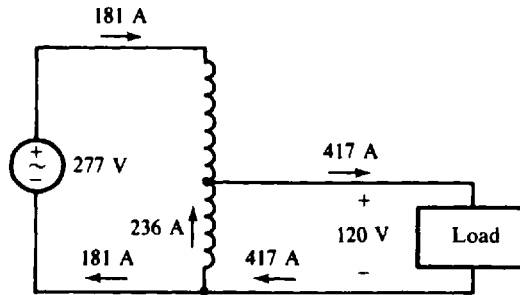

Fig. 16-31

16.44 A 12 470/277-V, 50-kVA transformer is connected as an autotransformer. What is the kVA rating if the windings are connected as shown in Fig. 16-7a? And what is this rating if the windings are connected as shown in Fig. 16-7b?

For either connection the maximum applied voltage is the sum of the voltage ratings of the windings: $12\,470 + 277 = 12\,747$ V. Since, for the connection shown in Fig. 16-7a, the source current flows through the low-voltage winding, the maximum input current is the current rating of this winding, which is $50\,000/277 = 181$ A. So, the kVA rating for this connection is $12\,747 \times 181 \text{ VA} = 2300 \text{ kVA}$. For the other connection, that illustrated in Fig. 16-7b, the source current flows through the high-voltage winding. Consequently, the maximum input current is the current rating of this winding, which is $50\,000/12\,470 = 4.01$ A, and the kVA rating is only $12\,747 \times 4.01 \text{ VA} = 51.1 \text{ kVA}$.

16.45 Find the three currents I_1 , I_2 , and I_3 for the circuit shown in Fig. 16-32.

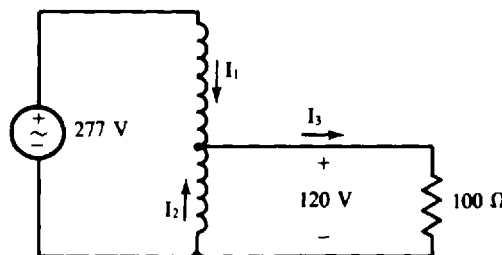

Fig. 16-32

The resistor current is obviously $I_3 = 120/100 = 1.2$ A. And the resistor receives $120 \times 1.2 = 144$ VA. Since this is also the voltamperes supplied by the source, then $277I_1 = 144$ and $I_1 = 144/277 = 0.52$ A. Last, from KCL applied at the transformer winding tap, $I_2 = I_3 - I_1 = 1.2 - 0.52 = 0.68$ A. Scalar addition can be used here since all three currents are in phase.

Supplementary Problems

- 16.46** In the transformer shown in Fig. 16-33, what is the direction of flux produced in the core by current flow into (a) terminal a, (b) terminal b, (c) terminal c, and (d) terminal d?

Ans. (a) Clockwise, (b) counterclockwise, (c) counterclockwise, (d) clockwise

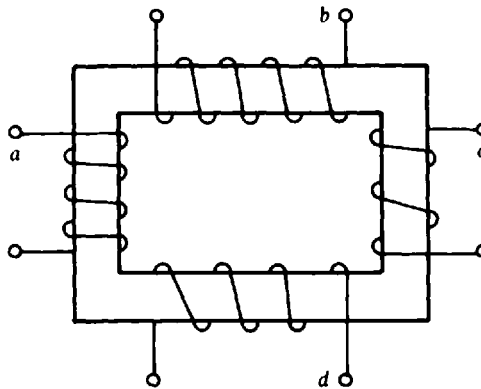

Fig. 16-33

- 16.47** Supply the missing dots for the transformers shown in Fig. 16-34.

Ans. (a) Dot on terminal d; (b) dot on terminal b; (c) dots on terminals b, c, and g.

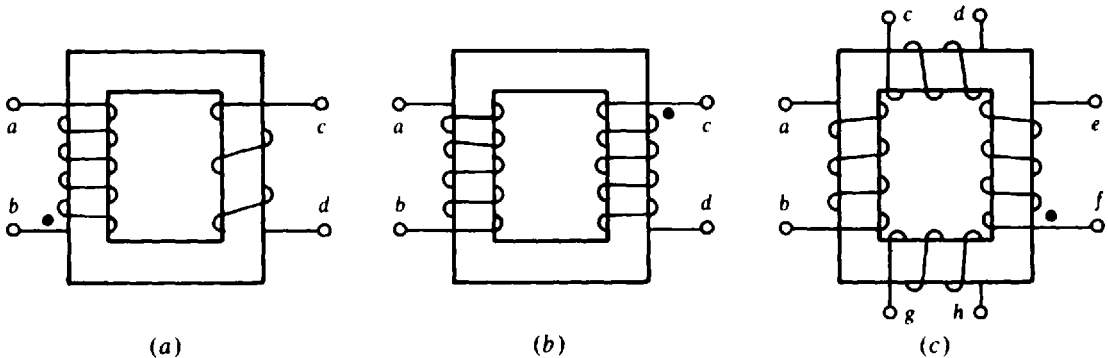

Fig. 16-34

- 16.48** What is the turns ratio of a power transformer that has a 6.25-A primary current at the same time that it has a 50-A secondary current?

Ans. $a = 8$.

- 16.49** Find the turns ratio of a power transformer that transforms the 12 470 V of a power line to the 480 V used in a factory.
Ans. $a = 26$.
- 16.50** What are the full-load primary and secondary currents of a 7200/120-V, 25-kVA power transformer? Assume that the 7200-V winding is the primary.
Ans. 3.47-A primary current and 208-A secondary current
- 16.51** A power transformer with a 13 200/480-V rating has a full-load primary current rating of 152 A. Find the transformer kVA rating and the full-load secondary current rating if the 480 V is the secondary voltage rating.
Ans. 2000 kVA, 4.18 kA
- 16.52** A 7200/120 V, 60-Hz transformer has 1620 turns on the primary. What is the peak rate of change of magnetic flux? (*Hint:* Remember that the voltage ratings are in rms.)
Ans. 6.29 Wb/s
- 16.53** An iron-core transformer has 3089 primary turns and 62 secondary turns. If the applied primary voltage is 13 800 V rms at 60 Hz, find the secondary rms voltage and the peak magnetic flux.
Ans. 277 V, 16.8 mWb
- 16.54** If a 27-turn transformer winding has 120 V rms applied, and if the peak coupling flux is 20 mWb, what is the frequency of the applied voltage?
Ans. 50 Hz
- 16.55** An iron-core transformer has 1620 primary turns and 54 secondary turns. A 10- Ω resistor is connected across the secondary winding. Find the resistor voltage when the primary current is 0.1 A.
Ans. 30 V
- 16.56** What should be the turns ratio of an output transformer that connects a 4- Ω speaker to an audio system that has an output resistance of 1600 Ω ?
Ans. $a = 20$
- 16.57** In the circuit shown in Fig. 16-35, what should a and X_C be for maximum average power absorption by the load impedance, and what is this power?
Ans. 3.19, -4.52Ω , 376 W

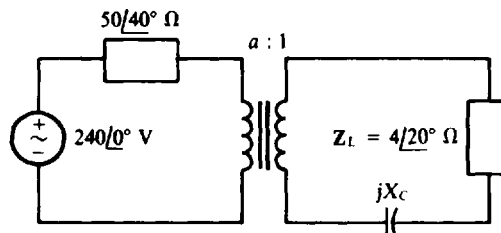

Fig. 16-35

16.58 Find i_1 , i_2 , and i_3 in the circuit shown in Fig. 16-36.

Ans. $i_1 = 4 \sin(3t - 36.9^\circ) \text{ A}$

$i_2 = 8 \sin(3t - 36.9^\circ) \text{ A}$

$i_3 = -24 \sin(3t - 36.9^\circ) \text{ A}$

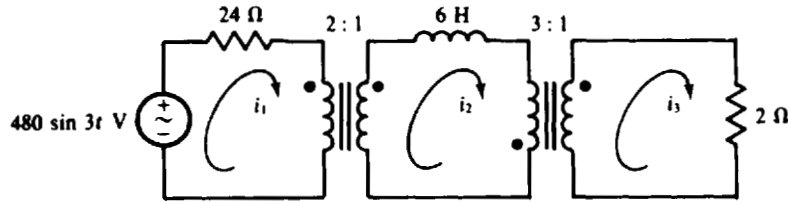

Fig. 16-36

16.59 Find V in the circuit shown in Fig. 16-37.

Ans. $-312/\underline{60.7^\circ} \text{ V}$

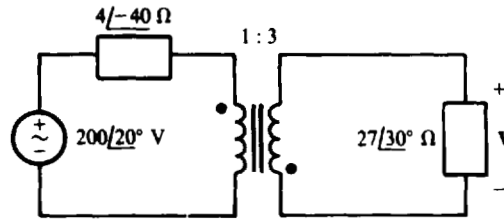

Fig. 16-37

16.60 Find I_1 , I_2 , and I_3 in the circuit shown in Fig. 16-38.

Ans. $I_1 = 1.49/\underline{-23.5^\circ} \text{ A}$, $I_2 = 4.46/\underline{-23.5^\circ} \text{ A}$, $I_3 = -8.93/\underline{-23.5^\circ} \text{ A}$

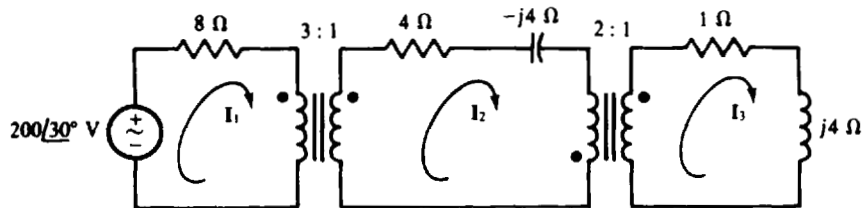

Fig. 16-38

16.61 What is v in the circuit shown in Fig. 16-39?

Ans. $-23.7 \sin(2t - 6.09^\circ) \text{ V}$

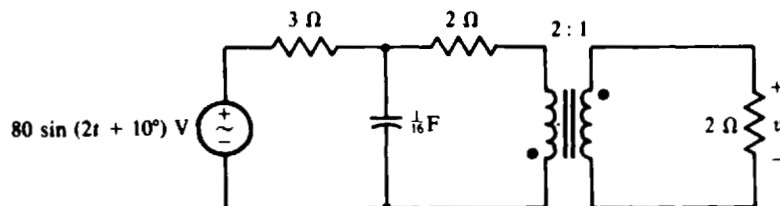

Fig. 16-39

16.62 Find I in the circuit shown in Fig. 16-40.

Ans. $2.28 \angle -39.7^\circ$ A

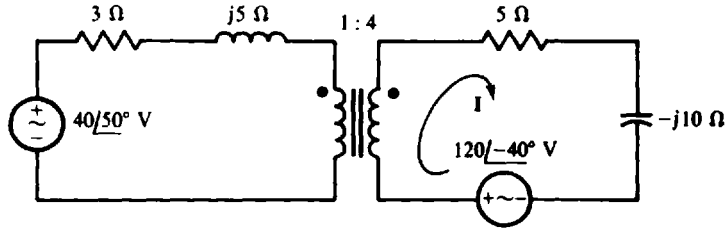

Fig. 16-40

16.63 For the following PSpice circuit file, construct a corresponding phasor-domain circuit diagram that contains an ideal transformer. Then use this diagram to calculate the answer that will appear in the output file when PSpice is run with this circuit file.

```

CIRCUIT FILE FOR PROB. 16.63
V1 1 0 AC 200 80
R1 1 2 8
L1 2 3 4
F1 3 0 V2 2
E1 0 4 3 0 2
V2 5 4
C1 5 6 6.25M
R2 6 0 60
.AC LIN 1 0.31831 0.31831
.PRINT AC VM(6) VP(6)
.END
    
```

Ans. $231.1 \angle -72.45^\circ$ V

16.64 Repeat Prob. 16.63 for the following PSpice circuit file.

```

CIRCUIT FILE FOR PROB. 16.64
V1 1 0 AC 12 30
R1 1 2 8
C1 2 3 20M
V2 3 4
E1 4 0 0 5 4
F1 5 0 V2 4
L1 5 6 1
R2 7 6 1
V3 7 0 AC 8 -20
.AC LIN 1 0.31831 0.31831
.PRINT AC IM(R2) IP(R2)
.END
    
```

Ans. $6.522 \angle -23.23^\circ$ A

16.65 Repeat Prob. 16.63 for the following PSpice circuit file.

```

CIRCUIT FILE FOR PROB. 16.65
V1 1 0 AC 16 20
R1 1 2 4
V2 2 3
E1 3 4 5 4 2
L1 4 0 5
F1 4 5 V2 2
C1 5 6 0.125
R2 6 0 6
R3 5 0 1MEG
.AC LIN 1 0.159155 0.159155
.PRINT AC VM(R2) VP(R2)
.END

```

Ans. $4.936/63.96^\circ$ V

16.66 An air-core transformer has a primary current of 0.2 A and a secondary current of 0.1 A that produce fluxes of $\phi_{11} = 40 \mu\text{Wb}$, $\phi_{m2} = 10 \mu\text{Wb}$, and $\phi_{12} = 30 \mu\text{Wb}$. Find ϕ_{m1} , L_1 , L_2 , M , and k if $N_1 = 30$ turns and $N_2 = 50$ turns.

Ans. $\phi_{m1} = 12 \mu\text{Wb}$, $L_1 = 7.8 \text{ mH}$, $L_2 = 20 \text{ mH}$, $M = 3 \text{ mH}$, $k = 0.24$

16.67 What is the greatest possible mutual inductance of an air-core transformer that has self-inductances of 120 and 90 mH?

Ans. 104 mH

16.68 For each of the following, find the missing quantity—either self-inductance, mutual inductance, or coefficient of coupling.

(a) $L_1 = 130 \text{ mH}$, $L_2 = 200 \text{ mH}$, $M = 64.5 \text{ mH}$

(b) $L_1 = 2.6 \mu\text{H}$, $L_2 = 3 \mu\text{H}$, $k = 0.4$

(c) $L_1 = 350 \text{ mH}$, $M = 100 \text{ mH}$, $k = 0.3$

Ans. (a) $k = 0.4$, (b) $M = 1.12 \mu\text{H}$, (c) $L_2 = 317 \text{ mH}$

16.69 An air-core transformer has an open-circuited secondary winding with 70 V induced in it when the primary winding carries a 0.3-A current and has a 120-V, 600-Hz voltage across it. What is the mutual inductance and the primary self-inductance?

Ans. $M = 61.9 \text{ mH}$, $L_1 = 106 \text{ mH}$

16.70 An air-core transformer with an open-circuited secondary has inductances of $L_1 = 200 \text{ mH}$, $L_2 = 320 \text{ mH}$, and $M = 130 \text{ mH}$. Find the primary and secondary voltages, referenced positive at the dotted terminals, when the primary current is increasing at the rate of 0.3 kA/s into the dotted terminal of the primary winding.

Ans. $v_1 = 60 \text{ V}$, $v_2 = 39 \text{ V}$

16.71 An air-core transformer has inductances of $L_1 = 0.3 \text{ H}$, $L_2 = 0.7 \text{ H}$, and $M = 0.3 \text{ H}$. The primary current is increasing into the dotted primary terminal at the rate of 200 A/s, and the secondary current is increasing into the dotted secondary terminal at the rate of 300 A/s. What are the primary and secondary voltages referenced positive at the dotted terminals?

Ans. $v_1 = 150 \text{ V}$, $v_2 = 270 \text{ V}$

16.72 An air-core transformer with a shorted secondary has a 90-mA short-circuit secondary current and a 150-mA primary current when 50 V at 400 Hz is applied to the primary. If the mutual inductance is 110 mH, find the self-inductances.

Ans. $L_1 = 199 \text{ mH}$, $L_2 = 183 \text{ mH}$

16.73 An air-core transformer with a shorted secondary has inductances of $L_1 = 0.6$ H, $L_2 = 0.4$ H, and $M = 0.2$ H. Find the winding currents when a primary voltage of 50 V at 60 Hz is applied.

Ans. $I_1 = 265$ mA, $I_2 = 133$ mA

16.74 A transformer has self-inductances of 1 and 0.6 H. One series connection of the windings results in a total inductance of 1 H. What is the coefficient of coupling?

Ans. $k = 0.387$

16.75 The transformer windings of a transformer are connected in series with dotted terminals adjacent. Find the total inductance of the series-connected windings if $L_1 = 0.6$ H, $L_2 = 0.4$ H, and $k = 0.35$.

Ans. 0.657 H

16.76 An air-core transformer has an 80-mH mutual inductance and a 200-mH secondary self-inductance. A 2-k Ω resistor and a 100-mH inductor are in series with the secondary winding. Find the impedance coupled into the primary for $\omega = 10$ krad/s.

Ans. $178 \angle -56.3^\circ \Omega$

16.77 Find V in the circuit of Fig. 16-41.

Ans. $-80 \angle -37.4^\circ$ V

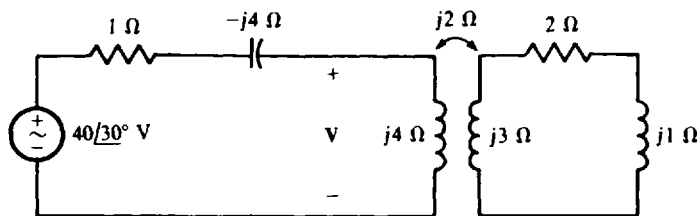

Fig. 16-41

16.78 A 6.8-k Ω resistor is connected across the secondary of a transformer having inductances of $L_1 = 150$ mH, $L_2 = 300$ mH, and $M = 64$ mH. What is the resistor current when 40 V at 10 krad/s is applied to the primary?

Ans. 2.33 mA

16.79 Find i in the circuit of Fig. 16-42.

Ans. $103 \sin(1000t - 73.1^\circ)$ mA

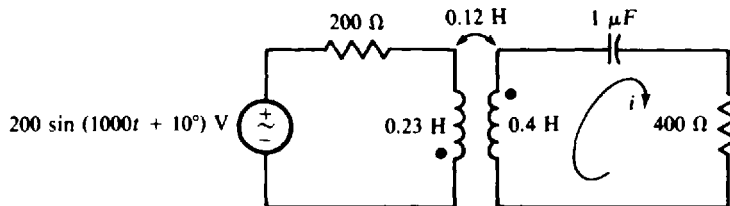

Fig. 16-42

16.80 What is the total inductance of the parallel-connected windings of an air-core transformer if the dots are at opposite ends and if the mutual inductance is 100 mH and the self-inductances are 200 and 400 mH?

Ans. 87.5 mH

16.81 Find i in the circuit of Fig. 16-43.

Ans. $24 \sin(2t - 76.6^\circ) \text{ A}$

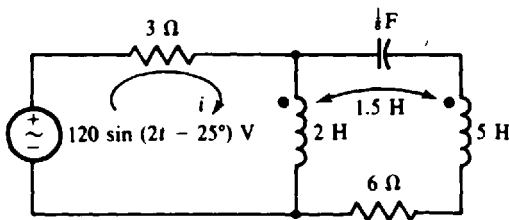

Fig. 16-43

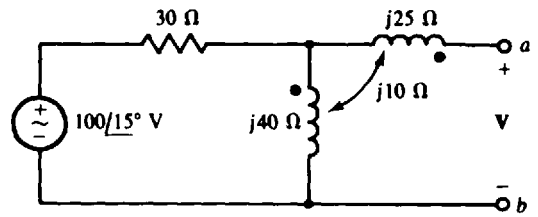

Fig. 16-44

16.82 Find V in the circuit of Fig. 16-44. Then switch the dot on one winding and find V again.

Ans. $100/51.9^\circ \text{ V}$, $60/51.9^\circ \text{ V}$

16.83 In the circuit shown in Fig. 16-44, place a short circuit across terminals a and b and find the short-circuit current directed from terminal a to terminal b .

Ans. $1.85/-4.44^\circ \text{ A}$

16.84 For the circuit shown in Fig. 16-44, what load connected to terminals a and b absorbs maximum power and what is this power?

Ans. $54.1/-56.3^\circ \Omega$, 83.3 W

16.85 Find I in the circuit of Fig. 16-45.

Ans. $7.38/39.4^\circ \text{ A}$

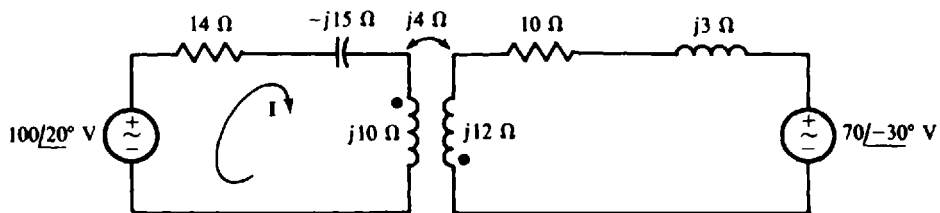

Fig. 16-45

16.86 Calculate the answer that will appear in the output file when PSpice is run with the following circuit file.

```

CIRCUIT FILE FOR PROB. 16.86
V1 1 0 AC 24 -50
R1 1 2 2
L1 2 0 2
L2 0 3 8
K1 L1 L2 0.5
R2 3 4 3
C1 4 0 0.25
.AC LIN 1 0.159155 0.159155
.PRINT AC IM(R1) IP(R1)
.END

```

Ans. $8.485/-78.74^\circ \text{ A}$

16.87 Calculate the answer that will appear in the output file when PSpice is run with the following circuit file.

```

CIRCUIT FILE FOR PROB. 16.87
V1 1 0 AC 50 75
R1 1 2 12
L1 2 0 2
L2 3 0 3.125
K1 L1 L2 0.4
R2 3 4 8
C1 4 5 0.025
V2 5 0 AC 30 -40
.AC LIN 1 0.31831 0.31831
.PRINT AC IM(R1) IP(R1)
.END
    
```

Ans. $3.657/\underline{53.20^\circ}$ A

16.88 Calculate the answer that will appear in the output file when PSpice is run with the following circuit file.

```

CIRCUIT FILE FOR PROB. 16.88
V1 1 0 AC 60 25
R1 1 2 20
L1 2 0 16
L2 0 3 4
K1 L1 L2 0.75
C1 3 4 0.2
R2 4 0 7
R3 1 4 11
.AC LIN 1 0.159155 0.159155
.PRINT AC VM(R3) VP(R3)
.END
    
```

Ans. $58.87/\underline{40.51^\circ}$ V

16.89 What is the turns ratio of a two-winding iron-core transformer that can be connected as a 277/120 V autotransformer?

Ans. $a = 1.31$ or $a = 0.764$

16.90 A 4800/240-V, 75-kVA power transformer is connected as an autotransformer. What is the kVA rating of the autotransformer for the connection shown in Fig. 16-7a? What is the kVA rating for the connection shown in Fig. 16-7b?

Ans. 1575 kVA, 78.75 kVA

16.91 Find the currents I_1 , I_2 , and I_3 in the circuit of Fig. 16-46.

Ans. $I_1 = 800$ A, $I_2 = 343$ A, $I_3 = 1.14$ kA

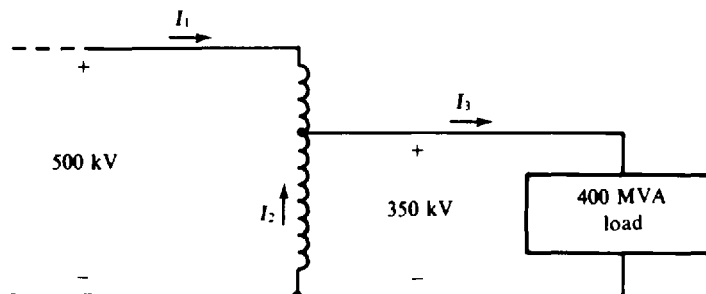

Fig. 16-46

Three-Phase Circuits

INTRODUCTION

Three-phase circuits are important because almost all electric power is generated and distributed three-phase. A three-phase circuit has an ac voltage generator, also called an *alternator*, that produces three sinusoidal voltages that are identical except for a phase angle difference of 120° . The electric energy is transmitted over either three or four wires, more often called *lines*. Most of the three-phase circuits presented in this chapter are *balanced*. In them, three of the line currents are identical except for a phase angle difference of 120° .

SUBSCRIPT NOTATION

The polarities of voltages in three-phase circuits are designated by double subscripts, as in V_{AB} . As may be recalled from Chap. 1, these subscripts identify the nodes that a voltage is across. Also, the order gives the voltage reference polarity. Specifically, the first subscript specifies the positively referenced node and the second subscript the negatively referenced node. So, V_{AB} is a voltage drop from node *A* to node *B*. Also, $V_{AB} = -V_{BA}$.

Double subscripts are also necessary for some current quantity symbols, as in I_{AB} . These subscripts identify the nodes between which I_{AB} flows, and the order of the subscripts specifies the current reference direction. Specifically, the current reference direction is from the node of the first subscript to the node of the second subscript. So, the current I_{AB} has a reference direction from node *A* to node *B*. Also, $I_{AB} = -I_{BA}$. Figure 17-1 illustrates the subscript convention for I_{AB} and also for V_{AB} .

Double subscript notation is also used for some impedances, as in Z_{AB} . The subscripts identify the two nodes that the impedance is connected between. But the order of the subscripts has no significance. Consequently, $Z_{AB} = Z_{BA}$.

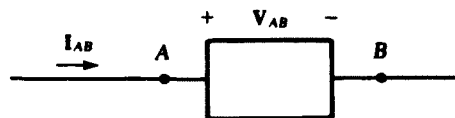

Fig. 17-1

THREE-PHASE VOLTAGE GENERATION

Figure 17-2a is a cross-sectional view of a three-phase alternator having a stationary stator and a counterclockwise rotating rotor. Physically displaced by 120° around the inner periphery of the stator are three sets of armature windings with terminals *A* and *A'*, *B* and *B'*, and *C* and *C'*. It is in these windings that the three-phase sinusoidal voltages are generated. The rotor has a field winding in which the flow of a dc current produces a magnetic field.

As the rotor rotates counterclockwise at 3600 r/min, its magnetic field cuts the armature windings, thereby inducing in them the sinusoidal voltages shown in Fig. 17-2b. These voltages have peaks at one-third of a period apart, or 120° apart, because of the 120° spatial displacement of the armature windings. As a result, the alternator produces three voltages of the same rms value, which may be as

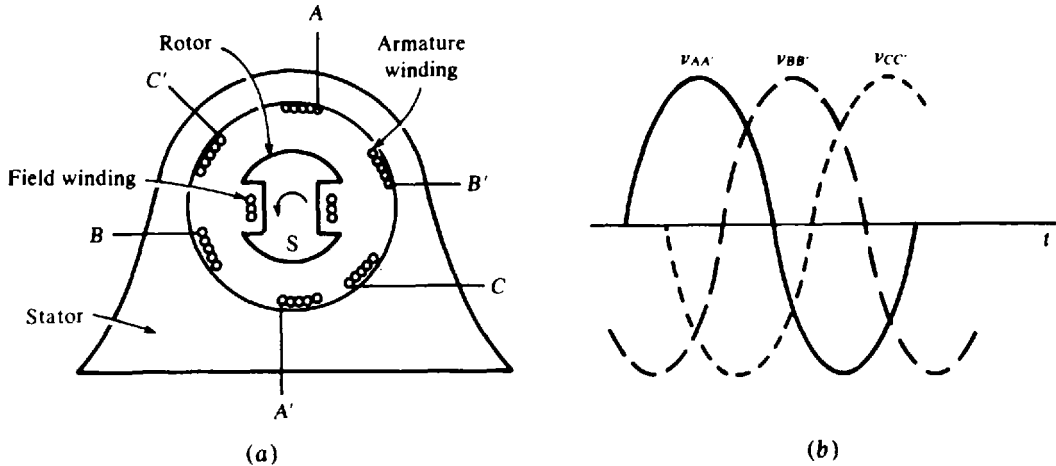

Fig. 17-2

great as 30 kV, and of the same frequency (60 Hz), but phase-shifted by 120°. These voltages might be, for example,

$$v_{AA'} = 25\,000 \sin 377t \text{ V}$$

$$v_{BB'} = 25\,000 \sin (377t - 120^\circ) \text{ V}$$

and

$$v_{CC'} = 25\,000 \sin (377t + 120^\circ) \text{ V}$$

If the voltages shown in Fig. 17-2b are evaluated at any one time, it will be found that they add to zero. This zero sum can also be shown by vector graphical addition of the phasors corresponding to these voltages. Figure 17-3a is a phasor diagram of the three phasors $V_{AA'}$, $V_{BB'}$, and $V_{CC'}$, corresponding to the generated voltages. These three phasors are added in Fig. 17-3b by connecting the tail of $V_{BB'}$ to the tip of $V_{AA'}$, and the tail of $V_{CC'}$ to the tip of $V_{BB'}$. Since the tip of $V_{CC'}$ touches the tail of $V_{AA'}$, the sum is zero. And since the sum of the phasor voltages is zero, the sum of the corresponding instantaneous voltages is zero for all times.

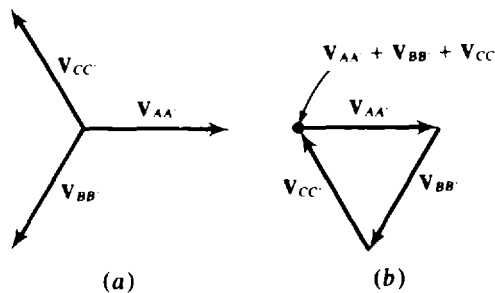

Fig. 17-3

In general, three sinusoids have a sum of zero if they have the same frequency and peak value but are phase-displaced by 120°. This is true regardless of what, if anything, that the sinusoids correspond to. In particular, it is true for currents.

GENERATOR WINDING CONNECTIONS

The ends of the generator windings are connected together to decrease the number of lines required for connections to loads. The primed terminals can be connected together to form the Y (wye) shown

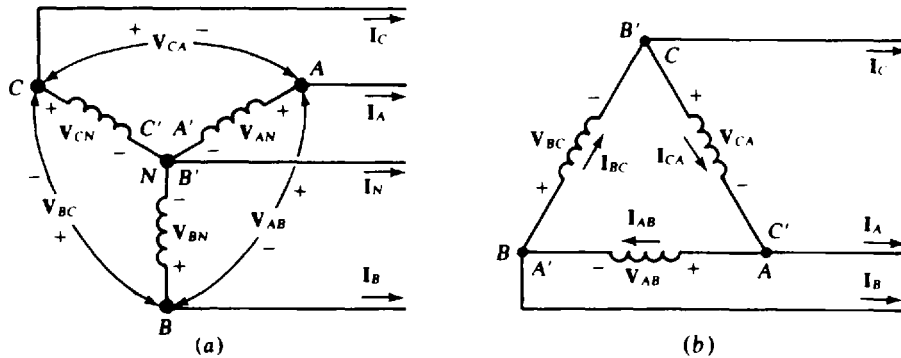

Fig. 17-4

in Fig. 17-4a, or primed terminals can be connected to unprimed terminals to form the Δ (delta) shown in Fig. 17-4b. The primed letters are included this once to show these connections. But since the terminals at which they are located also have unprimed letters, the primed letters are not necessary. These Y and Δ connections are not limited to generator windings but apply as well to transformer windings and load impedances. There are some practical reasons for preferring the Y connection for alternator windings, but both the Y and Δ connections are used for transformer windings and for load impedances. Incidentally, in circuit diagrams, sometimes circular ac generator symbols are used instead of the coil symbols.

In the Y connection shown in Fig. 17-4a, the primed terminals are joined at a common terminal marked N for *neutral*. There may be a line connected to this terminal, as shown, in which case there are four wires or lines. If no wire is connected to the neutral, the circuit is a three-wire circuit. The Δ connection illustrated in Fig. 17-4b inherently results in a three-wire circuit because there is no neutral terminal.

For the Y connection, the *line currents* are also the winding currents, also called *phase currents*. A line current is a current in one of the lines and by convention is referenced from the source to the load. A phase current is a current in a generator or transformer winding or in a single load impedance, which is also called a *phase* of the load.

A Y connection of windings or of impedances has two sets of voltages. There are the voltages V_{AN} , V_{BN} , and V_{CN} from terminals A , B , and C to the neutral terminal N . These are *phase voltages*. These differ from the *line-to-line voltages*, or just *line voltages*, V_{AB} , V_{BC} , and V_{CA} , across terminals A , B , and C . There are three other line voltages that have a 120° angle difference. These are V_{AC} , V_{BA} , and V_{CB} , which are the negatives of the other line voltages. In each set of line voltages, no two subscripts begin or end with the same letter. Also, no two pairs of subscripts have the same letters.

For the Δ shown in Fig. 17-4b, the line voltages are the same as the phase voltages. But the line currents I_A , I_B , and I_C differ from the phase currents I_{AB} , I_{BC} , and I_{CA} that flow through the windings. There is another suitable set of phase currents: I_{AC} , I_{BA} , and I_{CB} , which are the negatives of the currents in the first set.

PHASE SEQUENCE

The *phase sequence* of a three-phase circuit is the order in which the voltages or currents attain their maxima. For an illustration, Fig. 17-2b shows that $v_{AA'}$ peaks first, then $v_{BB'}$, then $v_{CC'}$, then $v_{AA'}$, etc., which is in the order of $\dots ABCABCAB \dots$. Any three adjacent letters can be selected to designate the phase sequence, but usually the three selected are ABC . This is sometimes called the *positive phase sequence*. If in Fig. 17-2a the labels of two windings are interchanged, or if the rotor is rotated clockwise instead of counterclockwise, the phase sequence is ACB (or CBA or BAC), also called the *negative phase sequence*. Although this explanation of phase sequence has been with respect to voltage peaking, phase sequence applies as well to current peaking.

Phase sequence can be related to the subscripts of voltage and current phasors. If, for example, V_{AN} has an angle 120° greater than that of V_{BN} , then v_{AN} must lead v_{BN} by 120° , and so the phase sequence must be ABC . Incidentally, the terms “lead” and “lag” are often applied to the voltage phasors as well as to the corresponding instantaneous voltages. For another example, if V_{CN} leads V_{BN} by 120° , then in the phase sequence the first subscript C of V_{CN} must be immediately ahead of the first subscript B of V_{BN} . Consequently, the phase sequence is CBA , or ACB , the negative phase sequence.

Phase sequence can be related to either the first or second subscripts of the line voltage phasors. This can be verified with an example. Figure 17-5a shows a phasor diagram of phase voltages V_{AN} , V_{BN} , and V_{CN} for an ABC phase sequence. Also included are terminals A , B , C , and N positioned such that lines drawn between them give the correct corresponding phasors. Drawn between terminals A , B , and C are a set of line voltage phasors: V_{AB} , V_{BC} , and V_{CA} , which are redrawn in the phasor diagram shown in Fig. 17-5b. Note that V_{AB} leads V_{BC} by 120° and that V_{BC} leads V_{CA} by 120° . On the basis of this leading, the order of the first set of subscripts is ABC , in agreement with the phase sequence. The order of the second set of subscripts is BCA , which is equivalent to ABC , also in agreement with the phase sequence. This order can also be found by using a reference point R on the phasor diagram, as shown. If the phasors are rotated *counterclockwise* about the origin, the first subscripts pass the reference point in the order of the phase sequence, as do the second subscripts.

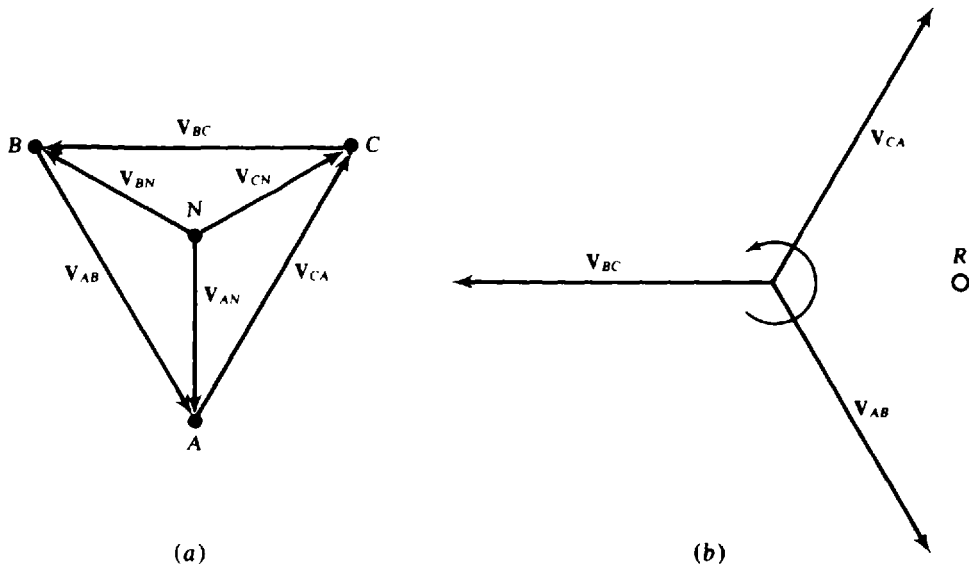

Fig. 17-5

In a similar manner it can be shown for a balanced circuit that the line current phasor subscripts correspond to the phase sequence order in the same way as explained for the voltage phasor subscripts. Also, the same is true for either the first or the second subscripts of the phase current phasors for a balanced Δ load. (A balanced Δ load has three equal impedances.)

BALANCED Y CIRCUIT

Figure 17-6 shows a *balanced Y circuit* that has a balanced Y load (a Y load of identical impedances) energized by a generator having Y-connected windings. Instead of generator windings, the windings could as well be the secondary windings of a three-phase transformer. A neutral wire connects the two neutral nodes.

A balanced three-phase circuit is easy to analyze because it is, in effect, three interconnected but separate circuits in which the only difference in responses is an angle difference of 120° . The general

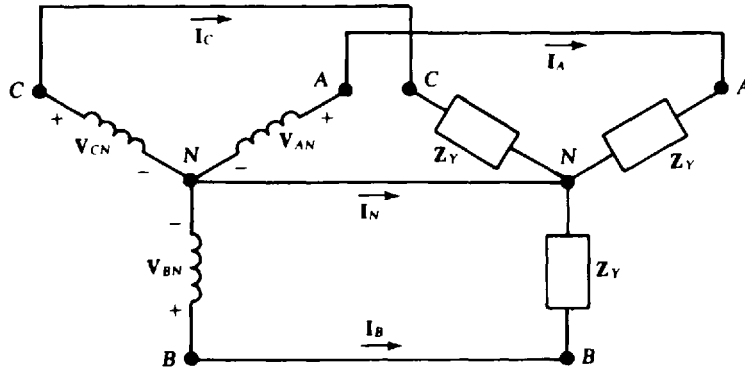

Fig. 17-6

analysis procedure is to find the desired voltage or current in one phase, and use it with the phase sequence to obtain the corresponding voltages or currents in the two other phases. For example, in the circuit shown in Fig. 17-6, the line current I_A can be found from $I_A = V_{AN}/Z_Y$. Then, I_B and I_C can be found from I_A and the phase sequence: They have the same magnitude as I_A , but lead and lag I_A by 120° as determined from the phase sequence.

Since the three currents I_A , I_B , and I_C have the same magnitude but a 120° angle difference, their sum is zero: $I_A + I_B + I_C = 0$. And from KCL, $I_N = -(I_A + I_B + I_C) = 0$ A. Because the neutral wire carries no current, it can be eliminated to change the circuit from a four-wire to a three-wire circuit. A further consequence of the zero neutral current is that *the two neutral nodes are at the same potential*, even without the neutral wire. In practice, though, it may be a good idea to have a small neutral wire to ensure balanced phase voltages in case the load impedances are not exactly the same.

The set of phase voltages and either set of line voltages for a balanced Y load have certain angle and magnitude relations that are *independent of the load impedance*. These relations can be obtained from one of the triangles shown in Fig. 17-5a. Consider the triangle formed by V_{BN} , V_{CN} , and V_{BC} . The largest angle is 120° , leaving $180 - 120 = 60^\circ$ for the other two angles. Since these two are opposite sides of equal length, they must be equal and so 30° each as shown in Fig. 17-7a. It can be seen that there is a 30° angle between line voltage V_{BC} and phase voltage V_{BN} , as is better shown in Fig. 17-7b. As should be evident from Fig. 17-5a, there is also a 30° angle difference between V_{AB} and V_{AN} and between V_{CA} and V_{CN} . In general, in the voltage phasor diagram for a balanced Y load, there is a 30° angle between each phase voltage and the nearest line voltage. This 30° can be either a lead or a lag, depending on the particular set of line voltages and also the phase sequence.

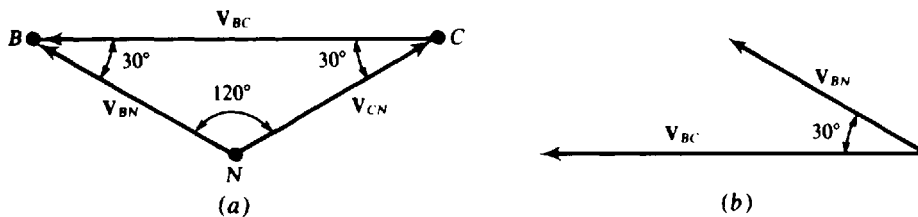

Fig. 17-7

Figure 17-8 has all the possible phasor diagrams that relate the Y phase voltages and the two sets of line voltages for the two phase sequences. Thus, all angle relations between the line and Y phase voltages can be determined from them. From the subscripts it should be apparent that Figs. 17-8a and b are for an ABC phase sequence and Figs. 17-8c and d are for an ACB phase sequence. Only relative angles are shown. For actual angles, the appropriate diagram would have to be rotated until any one phasor is at its specified angle, but this is seldom necessary.

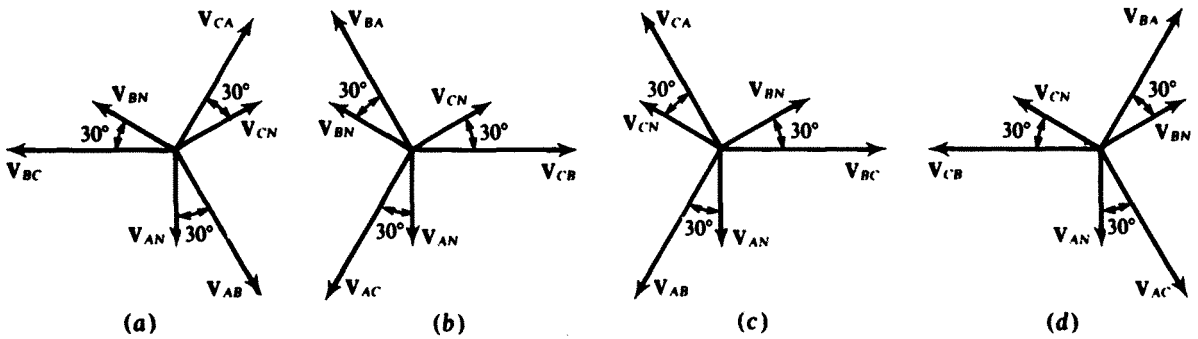

Fig. 17-8

There is also a relation between the magnitudes of the line and phase voltages. From Fig. 17-7a and the law of sines,

$$\frac{V_{BC}}{V_{BN}} = \frac{\sin 120}{\sin 30} = \frac{\sqrt{3}/2}{1/2} = \sqrt{3}$$

or $V_{BC} = \sqrt{3}V_{BN}$. In general, for a balanced Y load the line voltage magnitude V_L is $\sqrt{3}$ times V_p , the phase voltage magnitude: $V_L = \sqrt{3}V_p$.

Incidentally, in the description of a three-phase circuit the specified voltage should be assumed to be the rms line-to-line voltage.

BALANCED Δ LOAD

Figure 17-9 shows a balanced Δ load connected by three wires to a three-phase source. As a practical matter, this source is either a Y-connected alternator or, more probably, a Y- or Δ-connected secondary of a three-phase transformer. There is, of course, no neutral wire because a Δ load has only three terminals.

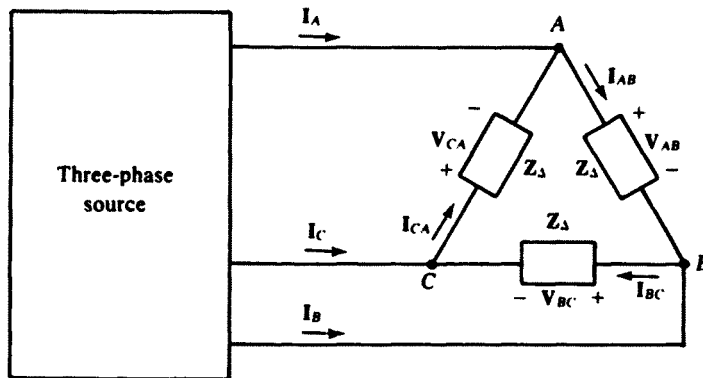

Fig. 17-9

The general procedure for finding the Δ phase currents is to first find one phase current and then use it with the phase sequence to find the other two. For example, the phase current I_{AB} can be found from $I_{AB} = V_{AB}/Z_{\Delta}$ and then I_{BC} and I_{CA} from I_{AB} and the phase sequence: These have the same magnitude as I_{AB} , but lead and lag I_{AB} by 120° as determined from the phase sequence.

The set of line currents and either set of phase currents for a balanced Δ have certain angle and magnitude relations that are independent of the load impedance. These can be found by applying KCL

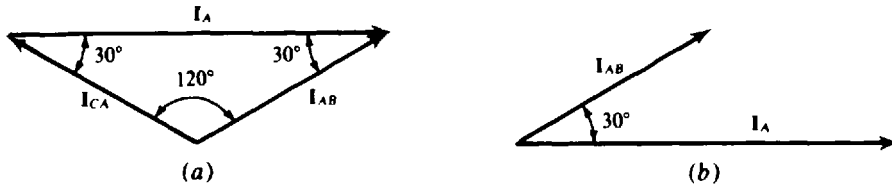

Fig. 17-10

at any terminal in the circuit shown in Fig. 17-9. If done at terminal *A*, the result is $I_A = I_{AB} - I_{CA}$. Figure 17-10a is a graphical representation of this subtraction for an *ABC* phase sequence. Since this is the same form of triangle as for the phase and line voltages of a balanced *Y* load, the results are similar: On a phasor diagram there is a 30° angle difference between each phase current and the nearest line current, as shown in Fig. 17-10b. This 30° can be either a lead or a lag, depending on the particular set of phase currents and on the phase sequence. Also, the line current magnitude I_L is $\sqrt{3}$ times I_p , the phase current magnitude: $I_L = \sqrt{3}I_p$.

Figure 17-11 has all the possible phasor diagrams that relate the line currents and the two sets of phase currents of balanced Δ loads for the two phase sequences. Thus all angle relations between the line and Δ phase currents can be determined from them. From the subscripts it should be evident that Figs. 17-11a and b are for an *ABC* phase sequence and that Figs. 17-11c and d are for an *ACB* phase sequence. Only relative angles are shown. For actual angles, the appropriate diagram would have to be rotated until any one phasor is at its specified angle, but this is seldom necessary.

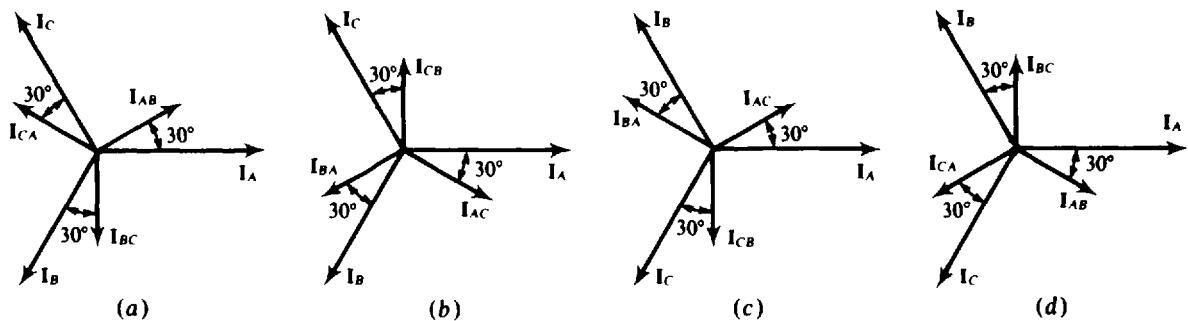

Fig. 17-11

PARALLEL LOADS

If a three-phase circuit has several loads connected in parallel, a good first step in an analysis is to combine the loads into a single *Y* or Δ load. Then, the analysis methods for a single *Y* or Δ load can be used. This combining is probably most obvious for two Δ 's, as shown in Fig. 17-12a. Being in parallel, corresponding phase impedances of the two Δ 's can be combined to produce a single equivalent Δ .

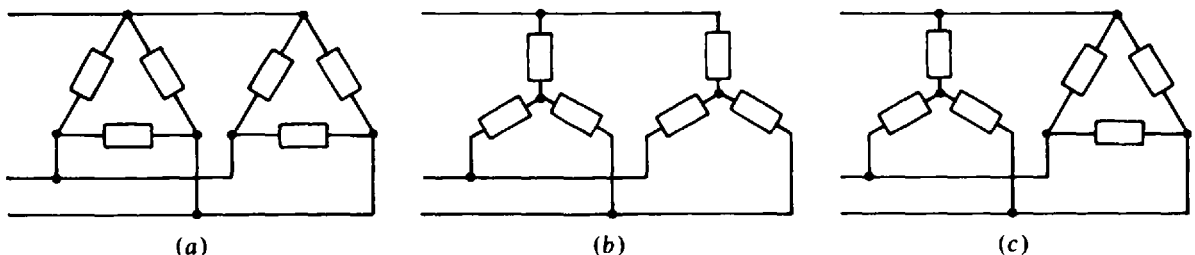

Fig. 17-12

If there are two Y loads, as shown in Fig. 17-12*b*, and if there is a neutral wire (not shown) connecting the two neutral nodes of the loads, corresponding phase impedances of the two Y's are in parallel and can be combined to produce a single equivalent Y. Even if there is no neutral wire, the corresponding phase impedances are in parallel provided that both Y loads are balanced because then both neutral nodes are at the same potential. If the loads are unbalanced and there is no neutral wire, corresponding impedances of the two Y's are *not* in parallel. Then, the two Y's can be transformed to two Δ 's, and these combined into a single equivalent Δ .

Sometimes a three-phase circuit has a Y load and a Δ load, as shown in Fig. 17-12*c*. If the loads are balanced, the Δ can be transformed to a Y and then the two Y's combined. If the loads are unbalanced, the Y can be transformed to a Δ and then the two Δ 's combined into a single equivalent Δ .

POWER

The average power absorbed by a balanced three-phase Y or Δ load is, of course, just three times the average power absorbed by any one of the phase impedances. For either a balanced Δ or a Y load, this is $P = 3V_p I_p \cos \theta$. The power formula is usually expressed in terms of the rms line voltage V_L and the rms line current I_L . For a Y load, $V_p = V_L/\sqrt{3}$ and $I_p = I_L$. And for a Δ load, $V_p = V_L$ and $I_p = I_L/\sqrt{3}$. With either substitution the result is the same:

$$P = \sqrt{3} V_L I_L \cos \theta$$

which is the formula for the total average power absorbed by either a balanced Y or Δ load. It is important to remember that θ is the load impedance angle and not the angle between a line voltage and line current.

Formulas for complex power S and reactive power Q can be readily found using the relations with average power presented in Chap. 15. For a balanced three-phase load, the result is

$$S = \sqrt{3} V_L I_L / \theta \quad \text{and} \quad Q = \sqrt{3} V_L I_L \sin \theta$$

Three-phase power factor correction is obtained with a balanced Y or Δ of capacitors, with each phase producing one-third of the required reactive power. Consequently, for each phase of a Δ the capacitance required is

$$C_{\Delta} = \frac{P[\tan(\cos^{-1} \text{PF}_i) - \tan(\cos^{-1} \text{PF}_f)]}{3\omega V_L^2}$$

But since for a Y the phase voltage is $V_L/\sqrt{3}$, the voltage factor in the denominator is $V_L^2/3$. So, the 3s divide out, with the result that

$$C_Y = \frac{P[\tan(\cos^{-1} \text{PF}_i) - \tan(\cos^{-1} \text{PF}_f)]}{\omega V_L^2}$$

Consequently, for a Y connection of power factor correction capacitors, the capacitance required in each phase is three times that required for a Δ . On the other hand, though, the breakdown voltage requirement is less for the Y-connected capacitors.

THREE-PHASE POWER MEASUREMENTS

If a three-phase load is balanced, the total average power absorbed can be measured by connecting a wattmeter into a single phase and multiplying the wattmeter reading by three. For this, the wattmeter current coil should be connected in series with a phase impedance and the wattmeter potential coil should be connected across this impedance. If the load is unbalanced, three measurements can be made, one in each phase.

Frequently, though, it is impossible to connect a wattmeter into a phase. This is true, for example, for the common three-phase electric motor that has just three wires extending from it. For such an application, the *two-wattmeter method* can be used, provided that there are just three wires to a load.

Figure 17-13 shows the wattmeter connections for the two-wattmeter method. Notice that the current coils are in series in two of the lines and that the respective potential coils are connected between these two lines and the third line. The \pm terminals are connected such that each wattmeter is connected as if to give an upscale reading for power absorbed by the load.

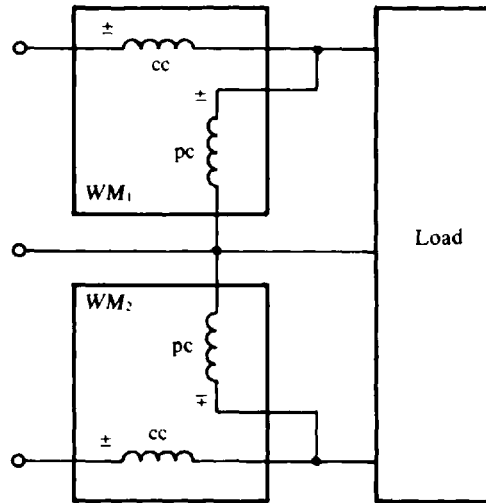

Fig. 17-13

It can be shown that the total average power absorbed by the load is equal to the *algebraic* sum of the two wattmeter readings. So, if one reading is negative, it is added, sign and all, to the other wattmeter reading. (Of course, it may be necessary to reverse a coil to obtain this reading.) This two-wattmeter method is completely general. The load does not have to be balanced. In fact, the circuit does not have to be three-phase or even sinusoidally excited.

From the line voltage and current phasors, it can be calculated that, for a balanced load with an impedance angle of θ , one wattmeter reading is $V_L I_L \cos(30^\circ + \theta)$ and the other is $V_L I_L \cos(30^\circ - \theta)$. The wattmeter with the $V_L I_L \cos(30^\circ + \theta)$ reading has a current coil in the line corresponding to the phase sequence letter that immediately precedes the letter of the line in which there is no current coil. If, for example, there is no current coil in line C, and if the phase sequence is *ABC*, then, since *B* precedes *C* in the phase sequence, the wattmeter with its current coil in line *B* has the $V_L I_L \cos(30^\circ + \theta)$ reading.

The impedance angle for the phase impedance of a balanced load can be found from the readings of wattmeters connected for the two-wattmeter method. There are six formulas that relate the tangent of the impedance angle to the power readings. The appropriate formula depends on the phase sequence and the lines in which the current coils are connected. If P_A , P_B , and P_C are the readings of wattmeters with current coils in lines *A*, *B*, and *C*, then, for an *ABC* phase sequence,

$$\tan \theta = \sqrt{3} \frac{P_A - P_B}{P_A + P_B} = \sqrt{3} \frac{P_B - P_C}{P_B + P_C} = \sqrt{3} \frac{P_C - P_A}{P_C + P_A}$$

For an *ACB* phase sequence, $\tan \theta$ equals the negative of these.

UNBALANCED CIRCUITS

If a three-phase circuit has an unbalanced load, none of the shortcuts for the analysis of balanced three-phase circuits can be used. Conventional mesh or loop analysis is usually preferable. If the load is an unbalanced Y with a neutral wire, then the voltage across each phase impedance is known, which means that each phase current can be readily found. The same is true for an unbalanced Δ load if there are no line impedances. Otherwise, it may be preferable to transform the Δ to a Y so that the line impedances are in series with the Y phase impedances.

PSpICE ANALYSIS OF THREE-PHASE CIRCUITS

PSpice applies to the analysis of a three-phase circuit, balanced or unbalanced, as to any ac circuit. There are, however, three special considerations. First, if a Y load has a series-connected capacitor in each phase and if there is no neutral wire, then PSpice will not complete an analysis because there is no dc path from the neutral node of this Y to the 0 node, assuming that this neutral node is not the 0 node. This problem is easily solved by inserting between these two nodes a resistor of extremely large resistance, thus providing the dc path without significantly affecting the analysis.

Second, a Δ - Δ circuit has no convenient node for the 0 node, which may or may not be important. If it is important, a balanced Y of resistors can be inserted and then the neutral node of this Y used for the 0 node. The resistance of each resistor should be large enough to avoid having the inserted Y affect the results.

Finally, PSpice will not analyze a circuit that has a Δ of voltage sources, inductors, or transformer windings, or a mixture of these. Inserting into this Δ a single resistor of negligibly small resistance will eliminate this problem as regards obtaining external voltages or currents. But if currents are of interest interior to a Δ of voltage sources, it is necessary to insert two other resistors to achieve balance. Otherwise, the obtained source currents will not even be approximately accurate.

Incidentally, for a Δ of voltage sources, one voltage source can be replaced by an open circuit to avoid having a loop of voltage sources. This deletion will not change the line voltages. It will, however, affect the currents flowing in the voltage sources, and so cannot be done if these currents are of interest. Similarly, for a three-phase transformer, if the windings are connected Δ - Δ , one primary winding and the corresponding secondary winding can be replaced by open circuits to avoid having loops of inductors. Electric utilities sometimes use two single-phase transformers in this manner to obtain three-phase transformer action. This is called an *open-delta installation*, and provides 57.7 percent of the capacity of a three-transformer bank. Utilities often use an open-delta installation when they know that the load will be increased in the future.

Solved Problems

- 17.1 What is the phase sequence of a balanced three-phase circuit in which $V_{AN} = 7200/\underline{20^\circ}$ V and $V_{CN} = 7200/\underline{-100^\circ}$ V? What is V_{BN} ?

Since V_{CN} lags V_{AN} by 120° , and the first subscripts are C and A, respectively, C follows A in the phase sequence. So, the phase sequence is ACB, the negative phase sequence. Of course, V_{BN} leads V_{AN} by 120° , but has the same magnitude: $V_{BN} = 7200/\underline{20^\circ + 120^\circ} = 7200/\underline{140^\circ}$ V.

- 17.2 What is the phase sequence of a balanced three-phase circuit in which $V_{BN} = 277/\underline{-30^\circ}$ V and $V_{CN} = 277/\underline{90^\circ}$ V? What is V_{AN} ?

Since V_{CN} leads V_{BN} by 120° , and the first subscripts are C and B , respectively, C leads B in the phase sequence, which must be CBA , or ACB , the negative phase sequence. Of course, V_{AN} has the same magnitude as V_{CN} , but has an angle that is 120° greater:

$$V_{AN} = 277/\underline{90} + 120 = 277/\underline{210} = 277/\underline{-150} \text{ V}$$

- 17.3** In a three-phase, three-wire circuit, find the phasor line currents to a balanced Y load in which each phase impedance is $Z_Y = 20/\underline{30} \Omega$. Also, $V_{AN} = 120/\underline{20} \text{ V}$, and the phase sequence is ABC .

The line current I_A can be found by dividing the phase voltage V_{AN} by the phase impedance Z_Y :

$$I_A = \frac{V_{AN}}{Z_Y} = \frac{120/\underline{20}}{20/\underline{30}} = 6/\underline{-10} \text{ A}$$

The other line currents can be determined from I_A and the phase sequence. They have the same magnitude as I_A , and for the specified ABC phase sequence, the currents I_B and I_C , respectively, lag and lead I_A by 120° . So,

$$I_B = 6/\underline{-10} - 120 = 6/\underline{-130} \text{ A} \quad \text{and} \quad I_C = 6/\underline{-10} + 120 = 6/\underline{110} \text{ A}$$

- 17.4** What is the phase sequence of a three-phase circuit in which $V_{AB} = 13\,200/\underline{-10} \text{ V}$ and $V_{BC} = 13\,200/\underline{110}^\circ \text{ V}$? Also, which line voltage has an angle that differs by 120° from the angles of these voltages?

The phase sequence can be found from the voltage angles and first subscripts. Since V_{BC} leads V_{AB} by 120° , and since the first subscripts are B and A , respectively, B is immediately ahead of A in the phase sequence. So the phase sequence must be BAC or equivalently, ACB , the negative phase sequence.

The third line voltage is either V_{CA} or V_{AC} because only A and C of ABC have not been used together in subscripts. The proper third line voltage—the voltage that has an angle differing by 120° from those of V_{AB} and V_{BC} —is V_{CA} since no two line voltages of a set can have subscripts that start with the same letter, as would be the case if V_{AC} were used. Thus, $V_{CA} = 13\,200/\underline{-130} \text{ V}$. This result is also obvious from Fig. 17-8c.

- 17.5** A balanced three-phase Y load has one phase voltage of $V_{CN} = 277/\underline{45} \text{ V}$. If the phase sequence is ACB , find the line voltages V_{CA} , V_{AB} , and V_{BC} .

From Fig. 17-8c, which is for an ACB phase sequence and the specified line voltages, it can be seen that the line voltage V_{CA} has an angle that is 30° less than that of V_{CN} . Its magnitude is, of course, greater by a factor of $\sqrt{3}$. So, $V_{CA} = 277\sqrt{3}/\underline{45} - 30 = 480/\underline{15} \text{ V}$. Also, $V_{AB} = 480/\underline{15} + 120 = 480/\underline{135} \text{ V}$, from the same figure or from the fact that V_{AB} has an angle that is 120° greater because its first subscript A is just ahead of the first subscript C of V_{CA} in the phase sequence ACB . Similarly, V_{BC} must lag V_{CA} by 120° : $V_{BC} = 480/\underline{15} - 120 = 480/\underline{-105} \text{ V}$.

- 17.6** What are the phase voltages for a balanced three-phase Y load if $V_{BA} = 12\,470/\underline{-35} \text{ V}$? The phase sequence is ABC .

From Fig. 17-8b, which is for an ABC phase sequence and the set of line voltages that includes V_{BA} , it can be seen that V_{BN} leads V_{BA} by 30° . Also, the magnitude of V_{BN} is less by a factor of $\sqrt{3}$. So,

$$V_{BN} = \frac{12\,470}{\sqrt{3}} / \underline{-35} + 30 = 7200/\underline{-5} \text{ V}$$

Also from this figure, or from the phase sequence and first subscript relation, V_{AN} leads V_{BN} by 120° , and V_{CN} lags it by 120° :

$$V_{AN} = 7200/\underline{-5} + 120 = 7200/\underline{115} \text{ V} \quad \text{and} \quad V_{CN} = 7200/\underline{-5} - 120 = 7200/\underline{-125} \text{ V}$$

- 17.7** A balanced three-phase, three-wire circuit with an ABC phase sequence has one line current of $\mathbf{I}_B = 20/\underline{40^\circ}$ A. Find the other line currents.

Because the circuit is balanced, all three line currents have the same magnitude of 20 A. And because the phase sequence is ABC , and A precedes B in the sequence, \mathbf{I}_A leads \mathbf{I}_B by 120° . For a similar reason, \mathbf{I}_C lags \mathbf{I}_B by 120° . Consequently,

$$\mathbf{I}_A = 20/\underline{40^\circ + 120^\circ} = 20/\underline{160^\circ} \text{ A} \quad \text{and} \quad \mathbf{I}_C = 20/\underline{40^\circ - 120^\circ} = 20/\underline{-80^\circ} \text{ A}$$

- 17.8** What is the \mathbf{I}_B line current in an unbalanced three-phase, three-wire circuit in which $\mathbf{I}_A = 50/\underline{60^\circ}$ A and $\mathbf{I}_C = 80/\underline{160^\circ}$ A?

By KCL, the sum of the three line currents is zero: $\mathbf{I}_A + \mathbf{I}_B + \mathbf{I}_C = 0$, from which $\mathbf{I}_B = -\mathbf{I}_A - \mathbf{I}_C = -50/\underline{60^\circ} - 80/\underline{160^\circ} = 86.7/\underline{-54.6^\circ}$ A.

- 17.9** A balanced Y load of $40\text{-}\Omega$ resistors is connected to a 480-V, three-phase, three-wire source. Find the rms line current.

Each line current is equal to the load phase voltage of $480/\sqrt{3} = 277$ V divided by the phase impedance of $40\ \Omega$: $I_L = 277/40 = 6.93$ A.

- 17.10** A balanced Y load of $50/\underline{-30^\circ}$ Ω impedances is energized by a 12 470-V, three-phase, three-wire source. Find the rms line current.

Each line current is equal to the load phase voltage of $12\ 470/\sqrt{3} = 7200$ V divided by the phase impedance magnitude of $50\ \Omega$: $I_L = 7200/50 = 144$ A.

- 17.11** Find the phasor line currents to a balanced Y load of impedances $\mathbf{Z}_Y = 50/\underline{25^\circ}$ Ω energized by a three-phase source. One phase voltage is $\mathbf{V}_{BN} = 120/\underline{30^\circ}$ V, and the phase sequence is ABC .

The line current \mathbf{I}_B can be found by dividing the phase voltage \mathbf{V}_{BN} by the phase impedance \mathbf{Z}_Y . Then the other line currents can be found from \mathbf{I}_B with the aid of the phase sequence. The line current \mathbf{I}_B is

$$\mathbf{I}_B = \frac{\mathbf{V}_{BN}}{\mathbf{Z}_Y} = \frac{120/\underline{30^\circ}}{50/\underline{25^\circ}} = 2.4/\underline{5^\circ} \text{ A}$$

Since the phase sequence is ABC , the angle of \mathbf{I}_A is 120° more than the angle of \mathbf{I}_B . Of course, the current magnitudes are the same: $\mathbf{I}_A = 2.4/\underline{5^\circ + 120^\circ} = 2.4/\underline{125^\circ}$ A. Similarly, the angle of \mathbf{I}_C is 120° less. So, $\mathbf{I}_C = 2.4/\underline{5^\circ - 120^\circ} = 2.4/\underline{-115^\circ}$ A.

- 17.12** In a three-phase, three-wire circuit, find the phasor line currents to a balanced Y load for which $\mathbf{Z}_Y = 60/\underline{-30^\circ}$ Ω and $\mathbf{V}_{CB} = 480/\underline{65^\circ}$ V. The phase sequence is ABC .

From Fig. 17-8b, the phase voltage \mathbf{V}_{CN} has an angle that is 30° greater than that of \mathbf{V}_{CB} and, of course, has a magnitude that is less by a factor of $1/\sqrt{3}$:

$$\mathbf{V}_{CN} = \frac{480/\underline{65^\circ + 30^\circ}}{\sqrt{3}} = 277/\underline{95^\circ} \text{ V}$$

The line current \mathbf{I}_C is

$$\mathbf{I}_C = \frac{\mathbf{V}_{CN}}{\mathbf{Z}_Y} = \frac{277/\underline{95^\circ}}{60/\underline{-30^\circ}} = 4.62/\underline{125^\circ} \text{ A}$$

Since A follows C in the phase sequence, \mathbf{I}_A lags \mathbf{I}_C by 120° : $\mathbf{I}_A = 4.62/\underline{125^\circ - 120^\circ} = 4.62/\underline{5^\circ}$ A. And because B precedes C in the phase sequence, \mathbf{I}_B leads \mathbf{I}_C by 120° :

$$\mathbf{I}_B = 4.62/\underline{125^\circ + 120^\circ} = 4.62/\underline{245^\circ} = 4.62/\underline{-115^\circ} \text{ A}$$

- 17.13** What is the phase sequence of a balanced three-phase circuit with a Δ load in which two of the phase currents are $\mathbf{I}_{BA} = 6\angle -30^\circ$ A and $\mathbf{I}_{CB} = 6\angle 90^\circ$ A? What is \mathbf{I}_{AC} ?

Since \mathbf{I}_{CB} , with a first subscript of C , has an angle 120° greater than that of \mathbf{I}_{BA} , which has a first subscript of B , the letter C precedes the letter B in the phase sequence. Thus the phase sequence must be ACB , the negative phase sequence. From this phase sequence, the current \mathbf{I}_{AC} , with a first subscript of A , has an angle that is 120° less than that of \mathbf{I}_{BA} . Of course, the magnitude is the same. So, $\mathbf{I}_{AC} = 6\angle -30^\circ - 120^\circ = 6\angle -150^\circ$ A.

- 17.14** Find the phase currents \mathbf{I}_{BC} , \mathbf{I}_{AB} , and \mathbf{I}_{CA} of a balanced three-phase Δ load to which one line current is $\mathbf{I}_B = 50\angle -40^\circ$ A. The phase sequence is ABC .

From Fig. 17-11a, which is for an ABC phase sequence and the specified set of Δ phase currents, it can be seen that \mathbf{I}_{BC} has an angle that is 30° greater than that of \mathbf{I}_B , and, of course, has a magnitude that is less by a factor of $1/\sqrt{3}$. Consequently,

$$\mathbf{I}_{BC} = \frac{50\angle -40^\circ + 30^\circ}{\sqrt{3}} = 28.9\angle -10^\circ \text{ A}$$

Also, from the same figure or from the fact that \mathbf{I}_{AB} has an angle that is 120° greater because its first subscript A is just ahead of the first subscript B of \mathbf{I}_{BC} in the phase sequence ABC , $\mathbf{I}_{AB} = 28.9\angle -10^\circ + 120^\circ = 28.9\angle 110^\circ$ A. Then \mathbf{I}_{CA} must have an angle that is 120° less than that of \mathbf{I}_{BC} . So, $\mathbf{I}_{CA} = 28.9\angle -10^\circ - 120^\circ = 28.9\angle -130^\circ$ A.

- 17.15** A balanced three-phase Δ load has one phase current of $\mathbf{I}_{BA} = 10\angle 30^\circ$ A. The phase sequence is ACB . Find the other phasor phase currents and also the phasor line currents.

The two other desired phase currents are those having angles that differ by 120° from the angle of \mathbf{I}_{BA} . These are \mathbf{I}_{AC} and \mathbf{I}_{CB} , as can be obtained from the relation of subscripts: No two currents can have the same first or second subscript letters, or the same two letters. This is also obvious from Fig. 17-11c. Since the phase sequence is ACB or negative, \mathbf{I}_{CB} must lead \mathbf{I}_{BA} by 120° because in the phase sequence the letter C , the first subscript letter of \mathbf{I}_{CB} , precedes the letter B , the first subscript letter of \mathbf{I}_{BA} . Also, Fig. 17-11c shows this 120° lead. Therefore, $\mathbf{I}_{CB} = 10\angle 30^\circ + 120^\circ = 10\angle 150^\circ$ A. Then \mathbf{I}_{AC} must lag \mathbf{I}_{BA} by 120° : $\mathbf{I}_{AC} = 10\angle 30^\circ - 120^\circ = 10\angle -90^\circ$ A.

From Fig. 17-11c, \mathbf{I}_A lags \mathbf{I}_{AC} by 30° , and since it has a magnitude that is greater by a factor of $\sqrt{3}$, $\mathbf{I}_A = 10\sqrt{3}\angle -90^\circ - 30^\circ = 17.3\angle -120^\circ$ A. Because the phase sequence is ACB , currents \mathbf{I}_B and \mathbf{I}_C , respectively, lead and lag \mathbf{I}_A by 120° :

$$\mathbf{I}_B = 17.3\angle -120^\circ + 120^\circ = 17.3\angle 0^\circ \text{ A} \quad \text{and} \quad \mathbf{I}_C = 17.3\angle -120^\circ - 120^\circ = 17.3\angle -240^\circ = 17.3\angle 120^\circ \text{ A}$$

- 17.16** What are the phasor line currents to a balanced three-phase Δ load if one phase current is $\mathbf{I}_{CB} = 10\angle 20^\circ$ A and if the phase sequence is ABC ?

From Fig. 17-11b, which is for an ABC phase sequence and the set of phase currents that includes \mathbf{I}_{CB} , it can be seen that \mathbf{I}_C leads \mathbf{I}_{CB} by 30° . Of course, its magnitude is greater by a factor of $\sqrt{3}$. So $\mathbf{I}_C = 10\sqrt{3}\angle 20^\circ + 30^\circ = 17.3\angle 50^\circ$ A. From the phase sequence, \mathbf{I}_B leads \mathbf{I}_C by 120° and \mathbf{I}_A lags it by 120° :

$$\mathbf{I}_B = 17.3\angle 50^\circ + 120^\circ = 17.3\angle 170^\circ \text{ A} \quad \text{and} \quad \mathbf{I}_A = 17.3\angle 50^\circ - 120^\circ = 17.3\angle -70^\circ \text{ A}$$

- 17.17** A 208-V three-phase circuit has a balanced Δ load of $50\text{-}\Omega$ resistors. Find the rms line current.

The rms line current I_L can be found from the rms phase current I_p , which is equal to the 208-V line voltage (and also phase voltage) divided by the $50\text{-}\Omega$ phase resistance: $I_p = 208/50 = 4.16$ A. The rms line current I_L is greater by a factor of $\sqrt{3}$: $I_L = \sqrt{3}(4.16) = 7.21$ A.

- 17.18** Find the phasor line currents to a balanced Δ three-phase load of impedances $\mathbf{Z}_A = 40\angle 10^\circ \Omega$ if one phase voltage is $\mathbf{V}_{CB} = 480\angle -15^\circ$ V and if the phase sequence is ACB .

A good first step is to find the phase current I_{CB} :

$$I_{CB} = \frac{V_{CB}}{Z_{\Delta}} = \frac{480/\underline{-15}}{40/\underline{10}} = 12/\underline{-25} \text{ A}$$

From Fig. 17-11c, which is for an ACB phase sequence and the set of phase currents that includes I_{CB} , the line current I_C lags I_{CB} by 30° . Of course, its magnitude is greater by a factor of $\sqrt{3}$. So

$$I_C = 12\sqrt{3}/\underline{-25 - 30} = 20.8/\underline{-55} \text{ A}$$

Since the phase sequence is ACB , the line currents I_A and I_B respectively lead and lag I_C by 120° :

$$I_A = 20.8/\underline{-55^\circ + 120^\circ} = 20.8/\underline{65} \text{ A} \quad \text{and} \quad I_B = 20.8/\underline{-55 - 120} = 20.8/\underline{-175} \text{ A}$$

- 17.19** A balanced Δ load of impedances $Z_{\Delta} = 24/\underline{-40^\circ} \Omega$ is connected to the Y-connected secondary of a three-phase transformer. The phase sequence is ACB and $V_{BN} = 277/\underline{50^\circ} \text{ V}$. Find the phasor line currents and load phase currents.

One approach is to find the corresponding Z_Y and use it to find I_B from $I_B = V_{BN}/Z_Y$. The next step is to use the phase sequence to obtain I_A and I_C from I_B . The last step is to use either Fig. 17-11c or d to obtain the phase currents from I_B . This is the approach that will be used, although there are other approaches just as short.

The corresponding Y impedance is $Z_Y = Z_{\Delta}/3 = (24/\underline{-40^\circ})/3 = 8/\underline{-40^\circ} \Omega$. And

$$I_B = \frac{V_{BN}}{Z_Y} = \frac{277/\underline{50^\circ}}{8/\underline{-40^\circ}} = 34.6/\underline{90^\circ} \text{ A}$$

Since the phase sequence is ACB , the line currents I_A and I_C respectively lag and lead I_B by 120° :

$$I_A = 34.6/\underline{90^\circ - 120^\circ} = 34.6/\underline{-30^\circ} \text{ A} \quad \text{and} \quad I_C = 34.6/\underline{90^\circ + 120^\circ} = 34.6/\underline{210^\circ} = 34.6/\underline{-150^\circ} \text{ A}$$

Either set of load phase currents can be found: I_{AB} , I_{BC} , and I_{CA} , or I_{BA} , I_{AC} , and I_{CB} . If the first set is selected, then Fig. 17-11d can be used, which has these currents for an ACB phase sequence. It can be seen that I_{AB} , I_{BC} , and I_{CA} lag I_A , I_B , and I_C respectively by 30° . The magnitude of each load phase current is, of course, $34.6/\sqrt{3} = 20 \text{ A}$. Thus,

$$I_{AB} = 20/\underline{-60^\circ} \text{ A} \quad I_{BC} = 20/\underline{60^\circ} \text{ A} \quad I_{CA} = 20/\underline{-180} = -20 \text{ A}$$

- 17.20** Find the rms line voltage V_L at the source of the circuit in Fig. 17-14. As shown, the rms load phase voltage is 100 V and each line impedance is $2 + j3 \Omega$.

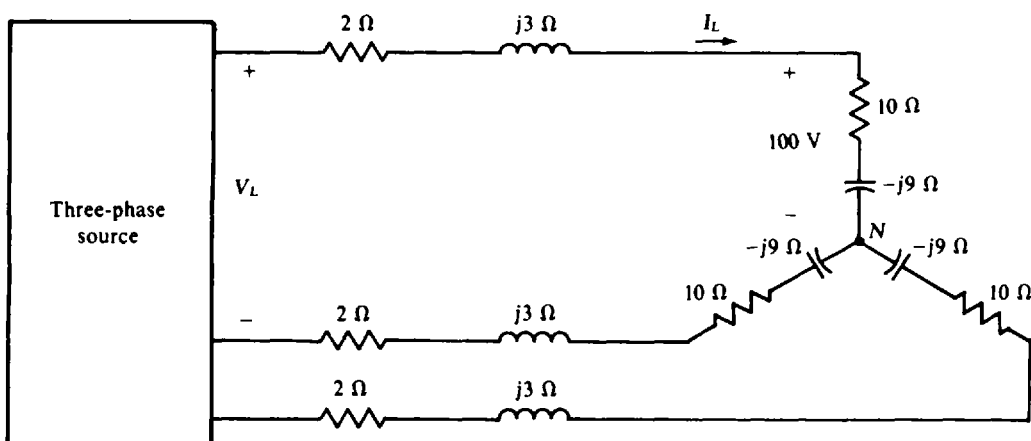

Fig. 17-14

The rms line current I_L can be used to find V_L . Of course, I_L is equal to the 100-V load phase voltage divided by the magnitude of the load phase impedance:

$$I_L = \frac{100}{|10 - j9|} = 7.43 \text{ A}$$

In flowing, this current produces a voltage drop from a source terminal to the load neutral terminal N , which drop is equal to the product of this current and the magnitude of the sum of the impedances that the current flows through. This voltage is

$$I_L |Z_{\text{line}} + Z_Y| = 7.43 |(2 + j3) + (10 - j9)| = 7.43 |12 - j6| = 7.43(13.42) = 99.7 \text{ V}$$

The line voltage at the source is equal to $\sqrt{3}$ times this: $V_L = \sqrt{3}(99.7) = 173 \text{ V}$.

- 17.21** Find the rms line voltage V_L at the source of the circuit in Fig. 17-15. As shown, the rms line voltage at the load is 100 V and each line impedance is $2 + j3 \Omega$.

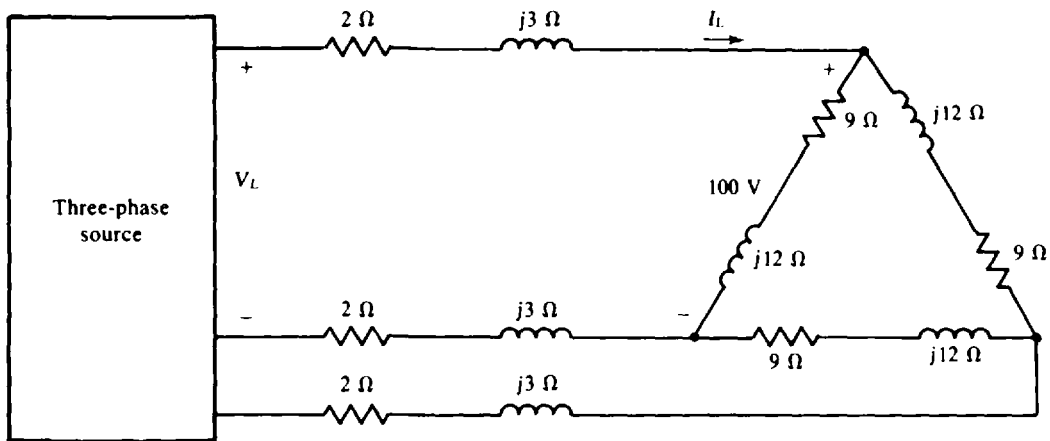

Fig. 17-15

Perhaps the best approach is to transform the Δ to an equivalent Y and then proceed as in the solution to Prob. 17.20. The equivalent Y impedance is $(9 + j12)/3 = 3 + j4 \Omega$. Since the line voltage at the load is 100 V, the line-to-neutral voltage for the equivalent Y load is $100/\sqrt{3} = 57.74 \text{ V}$. The rms line current I_L is equal to this voltage divided by the magnitude of the Y phase impedance:

$$I_L = \frac{57.74}{|3 + j4|} = \frac{57.74}{5} = 11.55 \text{ A}$$

In flowing, this current produces a voltage drop from a source terminal to the Y neutral terminal, which drop is equal to the product of this current and the magnitude of the sum of the impedances that the current flows through. The voltage is

$$I_L |Z_{\text{line}} + Z_Y| = 11.55 |(2 + j3) + (3 + j4)| = 11.55 |5 + j7| = 11.55(8.6) = 99.3 \text{ V}$$

And the line voltage at the source is equal to $\sqrt{3}$ times this: $V_L = \sqrt{3}(99.3) = 172 \text{ V}$.

- 17.22** A 480-V, three-phase, three-wire circuit has two parallel-connected balanced Δ loads, one of $5\text{-}\Omega$ resistors and the other of $20\text{-}\Omega$ resistors. Find the total rms line current.

Because the corresponding resistors of the Δ loads are in parallel, the resistances can be combined to produce an equivalent single Δ of $5 \cdot 20 = 4\text{-}\Omega$ resistors. The phase current of this Δ is equal to the line voltage divided by the 4Ω of resistance: $I_p = 480/4 = 120 \text{ A}$. And, of course, the line current is $\sqrt{3}$ times greater. So, $I_L = \sqrt{3}(120) = 208 \text{ A}$.

- 17.23** A 208-V, three-phase, three-wire circuit has two parallel-connected balanced Y loads, one of 6-Ω resistors and the other of 12-Ω resistors. Find the total rms line current.

Since the loads are balanced, the load neutral nodes are at the same potential even if there is no connection between them. Consequently, corresponding resistors are in parallel and can be combined. The result is a net resistance of $6 \parallel 12 = 4 \Omega$. This divided into the phase voltage of $208/\sqrt{3} = 120 \text{ V}$ gives the total rms line current: $I_L = 120/4 = 30 \text{ A}$.

- 17.24** A 600-V three-phase circuit has two parallel-connected balanced Δ loads, one of $40/\underline{30^\circ}$ -Ω impedances and the other of $50/\underline{-60^\circ}$ -Ω impedances. Find the total rms line current and also the total average absorbed power.

Being in parallel, corresponding Δ impedances can be combined to

$$\mathbf{Z}_{\Delta} = \frac{(40/\underline{30^\circ}) \parallel (50/\underline{-60^\circ})}{40/\underline{30^\circ} + 50/\underline{-60^\circ}} = \frac{2000/\underline{-30^\circ}}{64/\underline{-21.3^\circ}} = 31.2/\underline{-8.7^\circ} = 30.9 - j4.7 \Omega$$

The rms phase current for the combined Δ is equal to the line voltage divided by the magnitude of this impedance:

$$I_p = \frac{V_L}{Z_{\Delta}} = \frac{600}{31.2} = 19.2 \text{ A}$$

And the rms line current is $I_L = \sqrt{3}I_p = \sqrt{3}(19.2) = 33.3 \text{ A}$.

The total average power can be found using the phase current and resistance for the combined Δ :

$$P = 3I_p^2 R = 3(19.2)^2(30.9) = 34.2 \times 10^3 \text{ W} = 34.2 \text{ kW}$$

Alternatively, it can be found from the line quantities and the power factor:

$$P = \sqrt{3}V_L I_L \times \text{PF} = \sqrt{3}(600)(33.3) \cos(-8.7^\circ) = 34.2 \times 10^3 \text{ W} = 34.2 \text{ kW}$$

- 17.25** A 208-V three-phase circuit has two parallel-connected balanced loads, one a Δ of $21/\underline{30^\circ}$ -Ω impedances and the other a Y of $9/\underline{-60^\circ}$ -Ω impedances. Find the total rms line current and also the total average absorbed power.

The two loads can be combined if the Δ is transformed to a Y or if the Y is transformed to a Δ so that, in effect, the loads are in parallel. If the Δ is transformed to a Y, the equivalent Y has a phase impedance of $(21/\underline{30^\circ})/\sqrt{3} = 7/\underline{30^\circ} \Omega$. Since the circuit now has two balanced Y loads, corresponding impedances are in parallel and so can be combined:

$$\mathbf{Z}_Y = \frac{(7/\underline{30^\circ}) \parallel (9/\underline{-60^\circ})}{7/\underline{30^\circ} + 9/\underline{-60^\circ}} = \frac{63/\underline{-30^\circ}}{11.4/\underline{-22.13^\circ}} = 5.53/\underline{-7.87^\circ} = 5.47 - j0.76 \Omega$$

The rms line current is equal to the phase voltage of $V_p = 208/\sqrt{3} = 120 \text{ V}$ divided by the magnitude of the combined phase impedance:

$$I_L = \frac{V_p}{Z_Y} = \frac{120}{5.53} = 21.7 \text{ A}$$

Since this current effectively flows through the resistance of the combined Y, the total average power absorbed is

$$P = 3I_L^2 R = 3(21.7)^2(5.47) = 7.8 \times 10^3 \text{ W} = 7.8 \text{ kW}$$

Alternatively, the line voltage and current power formula can be used:

$$P = \sqrt{3}V_L I_L \times \text{PF} = \sqrt{3}(208)(21.7) \cos(-7.87^\circ) = 7.8 \times 10^3 \text{ W} = 7.8 \text{ kW}$$

- 17.26** A balanced Y of $20\angle 20^\circ\text{-}\Omega$ impedances and a parallel-connected balanced Δ of $42\angle 30^\circ\text{-}\Omega$ impedances are connected by three wires to the secondary of a three-phase transformer. If $V_{BC} = 480\angle 10^\circ\text{ V}$ and if the phase sequence is ABC , find the total phasor line currents.

A good approach is to obtain an equivalent single combined Y impedance, and also a phase voltage, and then find a line current by dividing this phase voltage by this impedance. The other line currents can be obtained from this line current by using the phase sequence. For this approach the first step is find the equivalent Y impedance for the Δ . It is $(42\angle 30^\circ)/3 = 14\angle 30^\circ\ \Omega$. The next step is to find a combined Y impedance Z_Y by using the parallel combination formula:

$$Z_Y = \frac{(20\angle 20^\circ)(14\angle 30^\circ)}{20\angle 20^\circ + 14\angle 30^\circ} = \frac{280\angle 50^\circ}{33.87\angle 24.1^\circ} = 8.27\angle 25.9^\circ\ \Omega$$

From Fig. 17-8a, which is for an ABC phase sequence, V_{BN} has an angle that is 30° less than that of V_{BC} and, of course, it has a magnitude that is less by a factor of $1/\sqrt{3}$:

$$V_{BN} = \frac{480\angle 10^\circ - 30^\circ}{\sqrt{3}} = 277\angle -20^\circ\ \text{V}$$

The line current I_B is equal to this voltage divided by the combined Y phase impedance:

$$I_B = \frac{V_{BN}}{Z_Y} = \frac{277\angle -20^\circ}{8.27\angle 25.9^\circ} = 33.5\angle -45.9^\circ\ \text{A}$$

From the phase sequence, the line currents I_A and I_C respectively lead and lag I_B by 120° : $I_A = 33.5\angle 74.1^\circ\ \text{A}$ and $I_C = 33.5\angle -165.9^\circ\ \text{A}$.

- 17.27** A balanced Δ load of $39\angle -40^\circ\text{-}\Omega$ impedances is connected by three wires, with $4\ \Omega$ of resistance each, to the secondary of a three-phase transformer. If the line voltage is 480 V at the secondary terminals, find the rms line current.

If the Δ is transformed to a Y, the Y impedances can be combined with the line resistances, and the line current found by dividing the magnitude of the total Y phase impedance into the phase voltage. The Y equivalent of the Δ has a phase impedance of

$$\frac{39\angle -40^\circ}{3} = 13\angle -40^\circ = 9.96 - j8.36\ \Omega$$

Being a Y impedance, this is in series with the line resistance and so can be combined with it. The result is

$$4 + (9.96 - j8.36) = 13.96 - j8.36 = 16.3\angle -30.9^\circ\ \Omega$$

And the rms line current is equal to the phase voltage of $480/\sqrt{3} = 277\text{ V}$ divided by the magnitude of this impedance: $I_L = 277/16.3 = 17\text{ A}$.

- 17.28** Find the average power absorbed by a balanced three-phase load in an ABC circuit in which $V_{CB} = 208\angle 15^\circ\text{ V}$ and $I_B = 3\angle 110^\circ\text{ A}$.

The formula $P = \sqrt{3}V_L I_L \times \text{PF}$ can be used if the power factor PF can be found. Since it is the cosine of the impedance angle, what is needed is the angle between a load phase voltage and current. With I_B known, the most convenient phase voltage is V_{BN} because the desired angle is that between V_{BN} and I_B . This approach is based on the assumption of a Y load, which is valid since any balanced load can be transformed to an equivalent Y. Figure 17-8b, which is for an ABC phase sequence, shows that V_{BN} leads V_{CB} by 150° , and so here has an angle of $15^\circ + 150^\circ = 165^\circ$. The power factor angle, the angle between V_{BN} and I_B , is $165^\circ - 110^\circ = 55^\circ$. So the average power absorbed by the load is

$$P = \sqrt{3}V_L I_L \times \text{PF} = \sqrt{3}(208)(3) \cos 55^\circ = 620\text{ W}$$

- 17.29** A three-phase induction motor delivers 20 hp while operating at an 85 percent efficiency and at a 0.8 lagging power factor from 480-V lines. Find the rms line current.

The current I_L can be found from the formula $P_{in} = \sqrt{3}V_L I_L \times \text{PF}$, in which P_{in} is the input power to the motor:

$$P_{in} = \frac{P_{out}}{\eta} = \frac{20 \times 745.7}{0.85} = 17.55 \times 10^3 \text{ W}$$

and

$$I_L = \frac{P_{in}}{\sqrt{3}V_L \times \text{PF}} = \frac{17.55 \times 10^3}{\sqrt{3}(480)(0.8)} = 26.4 \text{ A}$$

- 17.30** A three-phase induction motor delivers 100 hp while operating at an efficiency of 80 percent and a power factor of 0.75 lagging from 480-V lines. The power factor is to be improved to 0.9 lagging by inserting a Δ bank of power-factor correction capacitors. Determine the capacitance C_Δ required in each phase.

The input power to the motor is

$$P_{in} = \frac{P_{out}}{\eta} = \frac{100 \times 745.7}{0.8} \text{ W} = 93.2 \text{ kW}$$

So,

$$C_\Delta = \frac{(93.2 \times 10^3)[\tan(\cos^{-1} 0.75) - \tan(\cos^{-1} 0.9)]}{3(377)(480)^2} \text{ F} = 142.2 \mu\text{F}$$

- 17.31** In a 208-V three-phase circuit a balanced Δ load absorbs 2 kW at a 0.8 leading power factor. Find Z_Δ .

From $P = 3V_p I_p \times \text{PF}$, the phase current is

$$I_p = \frac{P}{3V_p \times \text{PF}} = \frac{2000}{3(208)(0.8)} = 4.01 \text{ A}$$

Since the line voltage is also the phase voltage, the magnitude of the phase impedance is

$$Z_\Delta = \frac{V_p}{I_p} = \frac{208}{4.01} = 51.9 \Omega$$

The impedance angle is the power factor angle: $\theta = -\cos^{-1} 0.8 = -36.9^\circ$. So the phase impedance is $Z_\Delta = 51.9 \angle -36.9^\circ \Omega$.

- 17.32** Given that $V_{AB} = 480 \angle 30^\circ \text{ V}$ in an ABC three-phase circuit, find the phasor line currents to a balanced load that absorbs 5 kW at a 0.6 lagging power factor.

From $P = \sqrt{3}V_L I_L \times \text{PF}$, the line current magnitude is

$$I_L = \frac{P}{\sqrt{3}V_L \times \text{PF}} = \frac{5000}{\sqrt{3}(480)(0.6)} = 10 \text{ A}$$

If, for convenience, a Y load is assumed, then from Fig. 17-8a, V_{AN} lags V_{AB} by 30° and so has an angle of $30^\circ - 30^\circ = 0^\circ$. Since I_A lags V_{AN} by the power factor angle of $\theta = \cos^{-1} 0.6 = 53.1^\circ$, I_A has an angle of $0^\circ - 53.1^\circ = -53.1^\circ$. Consequently, $I_A = 10 \angle -53.1^\circ \text{ A}$ and, from the ABC phase sequence,

$$I_B = 10 \angle -53.1^\circ - 120^\circ = 10 \angle -173.1^\circ \text{ A}$$

and

$$I_C = 10 \angle -53.1^\circ + 120^\circ = 10 \angle 66.9^\circ \text{ A}$$

- 17.33** A 480-V three-phase circuit has two balanced loads connected in parallel. One is a 5-kW resistive heater and the other an induction motor that delivers 15 hp while operating at an 80 percent efficiency and a 0.9 lagging power factor. Find the total rms line current.

A good approach is to find the total complex power S_T and then solve for I_L from $|S_T| = S_T = \sqrt{3}V_L I_L$, the apparent power. Since the heater is purely resistive, its complex power is $S_H = 5/0$ kVA. The complex power of the motor has a magnitude (the apparent power) that is equal to the input power divided by the power factor, and it has an angle that is the arccosine of the power factor:

$$S_M = \frac{15 \times 745.7}{0.8(0.9)} \angle \cos^{-1} 0.9 = 15.5 \times 10^3 / 25.8 \text{ VA} = 13.98 + j6.77 \text{ kVA}$$

The total complex power is the sum of these two complex powers:

$$S_T = S_H + S_M = 5 + (13.98 + j6.77) = 20.15/19.6 \text{ kVA}$$

Since the apparent power is $|S_T| = S_T = 20.15 \text{ kVA}$,

$$I_L = \frac{S_T}{\sqrt{3}V_L} = \frac{20.15 \times 10^3}{\sqrt{3}(480)} = 24.2 \text{ A}$$

- 17.34** If in a three-phase, three-wire, ABC circuit, $I_A = 10/\underline{-30}$ A, $I_B = 8/\underline{45}$ A, and $V_{AB} = 208/\underline{60}$ V, find the reading of a wattmeter connected with its current coil in line C and its potential coil across lines B and C . The \pm terminal of the current coil is toward the source, and the \pm terminal of the potential coil is at line C .

From the specified wattmeter connections, the wattmeter reading is equal to $P = V_L I_C \cos(\text{ang } V_{CB} - \text{ang } I_C)$. Of course, $V_L = 208 \text{ V}$. Also,

$$I_C = -I_A - I_B = -10/\underline{-30} - 8/\underline{45} = 14.3/\underline{-177.4} \text{ A}$$

From an inspection of Figs. 17-8a and b, it should be fairly apparent that V_{CB} leads V_{AB} by 60° and so here is $V_{CB} = 208/\underline{60} + 60 = 208/\underline{120}$ V. Therefore, the wattmeter reading is

$$P = 208(14.3) \cos [120 - (-177.4)] \text{ W} = 1.37 \text{ kW}$$

- 17.35** A balanced Y load of $25\text{-}\Omega$ resistors is energized from a 480-V, three-phase, three-wire, ABC source. Find the reading of a wattmeter connected with its current coil in line A and its potential coil across lines A and B . The \pm terminal of the current coil is toward the source, and the \pm terminal of the potential coil is at line A .

With the specified connections, the wattmeter has a reading equal to $P = V_L I_L \cos(\text{ang } V_{AB} - \text{ang } I_A)$, for which I_L and the angles of V_{AB} and I_A are needed. Since no phasors are specified in the problem statement, the phasor V_{AB} can be conveniently assigned a 0° angle: $V_{AB} = 480/0$ V. The current I_A can be found from the phase voltage V_{AN} and the phase resistance of 25Ω . Of course, V_{AN} has a magnitude of $480/\sqrt{3} = 277 \text{ V}$. Also, from Fig. 17-8a, it lags V_{AB} by 30° and so has an angle of $0 - 30 = -30^\circ$. Consequently, $V_{AN} = 277/\underline{-30}$ V and

$$I_A = \frac{V_{AN}}{R_Y} = \frac{277/\underline{-30}}{25} = 11.09/\underline{-30} \text{ A}$$

Since the magnitude of I_A is the rms line current,

$$P = V_L I_L \cos(\text{ang } V_{AB} - \text{ang } I_A) = 480(11.09) \cos [0 - (-30)] = 4.61 \times 10^3 \text{ W} = 4.61 \text{ kW}$$

Incidentally, this wattmeter reading is just half the total average power absorbed of $\sqrt{3}V_L I_L \times \text{PF} = \sqrt{3}(480)(11.09)(1) = 9220 \text{ W}$. As should be evident from the two-wattmeter formulas $V_L I_L \cos(30^\circ + \theta)$ and $V_L I_L \cos(30^\circ - \theta)$, this result is generally true for a purely resistive balanced load ($\theta = 0^\circ$) and a wattmeter connected as if it is one of the two wattmeters of the two-wattmeter method.

- 17.36** A balanced Δ load of $j40\text{-}\Omega$ inductors is energized from a 208-V, ACB source. Find the reading of a wattmeter connected with its current coil in line B and its potential coil across lines B and C . The \pm terminal of the current coil is toward the source, and the \pm terminal of the potential coil is at line B .

With the specified connections, the wattmeter has a reading equal to $P = V_L I_L \cos(\text{ang } \mathbf{V}_{BC} - \text{ang } \mathbf{I}_B)$, for which I_L and the angles of \mathbf{V}_{BC} and \mathbf{I}_B are needed. Since no phasors are specified, the phasor \mathbf{V}_{BC} can be conveniently assigned a 0° angle: $\mathbf{V}_{BC} = 208\angle 0^\circ$ V. Then $\mathbf{V}_{AB} = 208\angle -120^\circ$ V, as is apparent from the relation between the specified ACB phase sequence and the first subscripts. It follows that

$$\mathbf{I}_B = \mathbf{I}_{BC} - \mathbf{I}_{AB} = \frac{\mathbf{V}_{BC}}{Z_\Delta} - \frac{\mathbf{V}_{AB}}{Z_\Delta} = \frac{208\angle 0^\circ}{j40} - \frac{208\angle -120^\circ}{j40} = 9.01\angle -60^\circ \text{ A}$$

So the wattmeter reading is

$$P = V_L I_L \cos(\text{ang } \mathbf{V}_{BC} - \text{ang } \mathbf{I}_B) = 208(9.01) \cos [0^\circ - (-60^\circ)] = 937 \text{ W}$$

This reading has, of course, no relation to the average power absorbed by the load, which must be 0 W because the load is purely inductive.

- 17.37** A 240-V ABC circuit has a balanced Y load of $20\angle -60^\circ\text{-}\Omega$ impedances. Two wattmeters are connected for the two-wattmeter method with current coils in lines A and C . Find the wattmeter readings. Also, find these readings for an ACB phase sequence.

Since the line voltage magnitude and the impedance angle are known, only the line current magnitude is needed to determine the wattmeter readings. This current magnitude is

$$I_L = I_p = \frac{V_p}{Z_Y} = \frac{240}{20} \frac{\sqrt{3}}{2} = 6.93 \text{ A}$$

For the ABC phase sequence, the wattmeter with its current coil in line A has a reading of

$$P_A = V_L I_L \cos(30^\circ + \theta) = 240(6.93) \cos(30^\circ - 60^\circ) = 1440 \text{ W}$$

because A precedes B in the phase sequence and there is no current coil in line B . The other wattmeter reading is

$$P_C = V_L I_L \cos(30^\circ - \theta) = 240(6.93) \cos[30^\circ - (-60^\circ)] = 0 \text{ W}$$

Notice that one wattmeter reading is 0 W and the other is the total average power absorbed by the load, as is generally true for the two-wattmeter method for a balanced load with a power factor of 0.5.

For the ACB phase sequence, the wattmeter readings switch because C is before B in the phase sequence and there is no current coil in line B . So, $P_C = 1440 \text{ W}$ and $P_A = 0 \text{ W}$.

- 17.38** A 208-V circuit has a balanced Δ load of $30\angle 40^\circ\text{-}\Omega$ impedances. Two wattmeters are connected for the two-wattmeter method with current coils in lines A and B . Find the wattmeter readings for an ABC phase sequence.

The rms line current is needed for the wattmeter formulas. This current is $\sqrt{3}$ times the rms phase current:

$$I_L = \sqrt{3} I_p = \sqrt{3} \frac{V_p}{Z_\Delta} = \sqrt{3} \frac{208}{30} = 12 \text{ A}$$

Since there is no current coil in line C , and since B precedes C in the phase sequence, the reading of the wattmeter with its current coil in line B is

$$P_B = V_L I_L \cos(30^\circ + \theta) = 208(12) \cos(30^\circ + 40^\circ) = 854 \text{ W}$$

The other wattmeter reading is

$$P_A = V_L I_L \cos(30^\circ - \theta) = 208(12) \cos(30^\circ - 40^\circ) \text{ W} = 2.46 \text{ kW}$$

- 17.39** A balanced Y load is connected to a 480-V three-phase source. The two-wattmeter method is used to measure the average power absorbed by the load. If the wattmeter readings are 5 kW and 3 kW, find the impedance of each arm of the load.

Since the phase sequence and wattmeter connections are not given, only the magnitude of the impedance angle can be found from the wattmeter readings. From the angle-power formulas, this angle magnitude is

$$|\theta| = \tan^{-1} \left(\sqrt{3} \frac{5 - 3}{5 + 3} \right) = 23.4$$

The magnitude of the phase impedance Z_Y can be found from the ratio of the phase voltage and current. The phase voltage is $480/\sqrt{3} = 277$ V. The phase current, which is also the line current, can be found from the total power absorbed, which is $5 + 3 = 8$ kW:

$$I_p = I_L = \frac{P}{\sqrt{3}V_L \times \text{PF}} = \frac{8000}{\sqrt{3}(480)(\cos 23.4^\circ)} = 10.5 \text{ A}$$

From the ratio of the phase voltage and current, the magnitude of the phase impedance is $277/10.5 = 26.4 \Omega$. So the phase impedance is either $Z_Y = 26.4/\underline{23.4} \Omega$ or $Z_Y = 26.4/\underline{-23.4} \Omega$.

- 17.40** Two wattmeters both have readings of 3 kW when connected for the two-wattmeter method with current coils in lines *A* and *B* of a 600-V, *ABC* circuit having a balanced Δ load. Find the Δ phase impedance.

For an *ABC* phase sequence and current coils in lines *A* and *B*, the phase impedance angle is given by

$$\theta = \tan^{-1} \left(\sqrt{3} \frac{P_A - P_B}{P_A + P_B} \right) = \tan^{-1} \left(\sqrt{3} \frac{3 - 3}{3 + 3} \right) = \tan^{-1} 0 = 0$$

Because the load impedance angle is 0° , the load is purely resistive. The phase resistance is equal to the phase voltage of 600 V, which is also the line voltage, divided by the phase current. From $P = 3V_p I_p \cos \theta$,

$$I_p = \frac{P}{3V_p \cos \theta} = \frac{3000 + 3000}{3(600)(1)} = 3.33 \text{ A}$$

Finally,

$$R_\Delta = \frac{V_p}{I_p} = \frac{600}{3.33} = 180 \Omega$$

- 17.41** Two wattmeters are connected for the two-wattmeter method with current coils in lines *B* and *C* of a 480-V, *ACB* circuit that has a balanced Δ load. If the wattmeter readings are 4 kW and 2 kW, respectively, find the Δ phase impedance Z_Δ .

The phase impedance angle is

$$\theta = \tan^{-1} \left(\sqrt{3} \frac{P_C - P_B}{P_C + P_B} \right) = \tan^{-1} \left(\sqrt{3} \frac{2 - 4}{2 + 4} \right) = \tan^{-1} \left(-\frac{\sqrt{3}}{3} \right) = -30^\circ$$

The magnitude of the phase impedance can be found by dividing the phase voltage of 480 V, which is also the line voltage, by the phase current. From $P = 3V_p I_p \cos \theta$, the phase current is

$$I_p = \frac{P}{3V_p \cos \theta} = \frac{4000 + 2000}{3(480) \cos(-30^\circ)} = 4.81 \text{ A}$$

This divided into the phase voltage is the magnitude of the phase impedance. Consequently,

$$Z_\Delta = \frac{480}{4.81} \underline{-30^\circ} = 99.8 \underline{-30^\circ} \Omega$$

17.42 Two wattmeters are connected for the two-wattmeter method with current coils in lines *A* and *C* of a 240-V, *ACB* circuit that has a balanced Y load. Find the Y phase impedance if the two wattmeter readings are -1 kW and 2 kW, respectively.

The impedance angle is

$$\theta = \tan^{-1} \left(\sqrt{3} \frac{P_A - P_C}{P_A + P_C} \right) = \tan^{-1} \left(\sqrt{3} \frac{-1 - 2}{-1 + 2} \right) = \tan^{-1} (-3\sqrt{3}) = -79.1$$

The magnitude of the phase impedance can be found by dividing the phase voltage of $V_p = 240/\sqrt{3} = 139$ V by the phase current, which is also the line current. From $P = \sqrt{3} V_L I_L \cos \theta$, the line current is

$$I_L = I_p = \frac{P}{\sqrt{3} V_L \cos \theta} = \frac{-1000 + 2000}{\sqrt{3}(240) \cos(-79.1)} = 12.7 \text{ A}$$

So
$$Z_Y = \frac{139}{12.7} \angle -79.1 = 10.9 \angle -79.1 \ \Omega$$

17.43 A 240-V, *ABC* circuit has an unbalanced Δ load consisting of resistors $R_{AC} = 45 \ \Omega$, $R_{BA} = 30 \ \Omega$, and $R_{CB} = 40 \ \Omega$. Two wattmeters are connected for the two-wattmeter method with current coils in lines *A* and *B*. What are the wattmeter readings and the total average power absorbed?

From the wattmeter connections, the wattmeter readings are equal to

$$P_A = V_{AC} I_A \cos(\text{ang } V_{AC} - \text{ang } I_A) \quad \text{and} \quad P_B = V_{BC} I_B \cos(\text{ang } V_{BC} - \text{ang } I_B)$$

For the calculations of these powers, the phasors V_{AC} , V_{BC} , I_A , and I_B are needed. Since no angles are specified, the angle of V_{AC} can be conveniently selected as 0° , making $V_{AC} = 240 \angle 0^\circ$ V. For an *ABC* phase sequence, V_{CB} leads V_{AC} by 120° and so is $V_{CB} = 240 \angle 120^\circ$ V. But V_{BC} is needed:

$$V_{BC} = -V_{CB} = -240 \angle 120^\circ = 240 \angle 120^\circ - 180^\circ = 240 \angle -60^\circ \text{ V}$$

Also, V_{BA} lags V_{AC} by 120° and is $V_{BA} = 240 \angle -120^\circ$ V. The line currents I_A and I_B can be determined from the phase currents:

$$I_A = I_{AC} - I_{BA} = \frac{V_{AC}}{R_{AC}} - \frac{V_{BA}}{R_{BA}} = \frac{240 \angle 0^\circ}{45} - \frac{240 \angle -120^\circ}{30} = 11.6 \angle 36.6^\circ \text{ A}$$

$$I_B = I_{BA} - I_{CB} = \frac{V_{BA}}{R_{BA}} - \frac{V_{CB}}{R_{CB}} = \frac{240 \angle -120^\circ}{30} - \frac{240 \angle 120^\circ}{40} = 12.2 \angle -94.7^\circ \text{ A}$$

Now P_A and P_B can be determined:

$$P_A = V_{AC} I_A \cos(\text{ang } V_{AC} - \text{ang } I_A) = 240(11.6) \cos(0^\circ - 36.6^\circ) \text{ W} = 2.24 \text{ kW}$$

$$P_B = V_{BC} I_B \cos(\text{ang } V_{BC} - \text{ang } I_B) = 240(12.2) \cos[-60^\circ - (-94.7^\circ)] \text{ W} = 2.4 \text{ kW}$$

Notice that the two wattmeter readings are not the same, even though the load is purely resistive. The reason they are not the same is that the load is not balanced.

The total power absorbed is $P_A + P_B = 2.24 + 2.4 = 4.64$ kW. This can be checked by summing the V^2/R power absorptions by the individual resistors:

$$P_T = \frac{240^2}{45} + \frac{240^2}{30} + \frac{240^2}{40} \text{ W} = 4.64 \text{ kW}$$

17.44 For a four-wire, *ACB* circuit in which $V_{AN} = 277 \angle -40^\circ$ V, find the four phasor line currents to a Y load of $Z_A = 15 \angle 30^\circ \ \Omega$, $Z_B = 20 \angle -25^\circ \ \Omega$, and $Z_C = 25 \angle 45^\circ \ \Omega$.

The three phase currents, which are also three of the line currents, are equal to the phase voltages divided by the phase impedances. One phase voltage is the specified V_{AN} . The others are V_{BN} and V_{CN} .

From the specified ACB phase sequence, the voltages V_{BN} and V_{CN} respectively lead and lag V_{AN} by 120° : $V_{BN} = 277/80^\circ$ V and $V_{CN} = 277/-160^\circ$ V. So the phase currents are

$$\begin{aligned} I_A &= \frac{V_{AN}}{Z_A} = \frac{277/-40^\circ}{15/30^\circ} = 18.5/-70^\circ \text{ A} & I_B &= \frac{V_{BN}}{Z_B} = \frac{277/80^\circ}{20/-25^\circ} = 13.9/105^\circ \text{ A} \\ I_C &= \frac{V_{CN}}{Z_C} = \frac{277/-160^\circ}{25/45^\circ} = 11.1/-205^\circ = -11.1/-25^\circ \text{ A} \end{aligned}$$

By KCL the neutral line current is

$$I_N = -(I_A + I_B + I_C) = -(18.5/-70^\circ + 13.9/105^\circ - 11.1/-25^\circ) = 7.3/-5.53^\circ \text{ A}$$

- 17.45** For an ABC circuit in which $V_{AB} = 480/40^\circ$ V, find the phasor line currents to a Δ load of $Z_{AB} = 40/30^\circ \Omega$, $Z_{BC} = 30/-70^\circ \Omega$, and $Z_{CA} = 50/60^\circ \Omega$.

Each line current is the difference of two phase currents, and each phase current is the ratio of a phase voltage and impedance. One phase voltage is the given $V_{AB} = 480/40^\circ$ V. And from the given ABC phase sequence, the other phase voltages, V_{BC} and V_{CA} , respectively lag and lead V_{AB} by 120° : $V_{BC} = 480/-80^\circ$ V and $V_{CA} = 480/160^\circ$ V. So the phase currents are

$$\begin{aligned} I_{AB} &= \frac{V_{AB}}{Z_{AB}} = \frac{480/40^\circ}{40/30^\circ} = 12/10^\circ \text{ A} & I_{BC} &= \frac{V_{BC}}{Z_{BC}} = \frac{480/-80^\circ}{30/-70^\circ} = 16/-10^\circ \text{ A} \\ I_{CA} &= \frac{V_{CA}}{Z_{CA}} = \frac{480/160^\circ}{50/60^\circ} = 9.6/100^\circ \text{ A} \end{aligned}$$

And, by KCL, the line currents are

$$\begin{aligned} I_A &= I_{AB} - I_{CA} = 12/10^\circ - 9.6/100^\circ = 15.4/-28.7^\circ \text{ A} \\ I_B &= I_{BC} - I_{AB} = 16/-10^\circ - 12/10^\circ = 6.26/-51^\circ \text{ A} \\ I_C &= I_{CA} - I_{BC} = 9.6/100^\circ - 16/-10^\circ = 21.3/144.9^\circ = -21.3/-35.1^\circ \text{ A} \end{aligned}$$

As a check, the three line currents can be added to see if the sum is zero, as it should be by KCL. This sum is zero, but it takes more than three significant digits to show this convincingly.

- 17.46** In a three-wire, ABC circuit in which $V_{AB} = 480/60^\circ$ V, find the phasor line currents to a Y load of $Z_A = 16/-30^\circ \Omega$, $Z_B = 14/50^\circ \Omega$, and $Z_C = 12/-40^\circ \Omega$.

Since the Y load is unbalanced and there is no neutral wire, the load phase voltages are not known. And this means that the line currents cannot be found readily by dividing the load phase voltages by the load phase impedances, as in the solution to Prob. 17.44. A Y -to- Δ transformation is tempting so that the phase voltages will be known and the approach in the solution to Prob. 17.45 can be used. But usually this is considerably more effort than using loop analysis on the original circuit.

As shown in Fig. 17-16, loop analysis can be used to find two of the three line currents, here I_A and I_C . Of course, after these are known, the third line current I_B can be found from them by KCL. Note in Fig. 17-16 that the V_{CA} generator is not shown. It is not needed because the shown two generators illustrated supply the correct voltage between terminals A and C . Of course, as shown, V_{BC} lags the given V_{AB} by 120° because the phase sequence is ABC .

The loop equations are

$$\begin{aligned} (16/-30^\circ + 14/50^\circ)I_A + (14/50^\circ)I_C &= 480/60^\circ \\ (14/50^\circ)I_A + (12/-40^\circ + 14/50^\circ)I_C &= -480/-60^\circ \end{aligned}$$

which simplify to

$$\begin{aligned} (23/6.8)I_A + (14/50^\circ)I_C &= 480/60^\circ \\ (14/50^\circ)I_A + (18.4/9.4)I_C &= -480/-60^\circ \end{aligned}$$

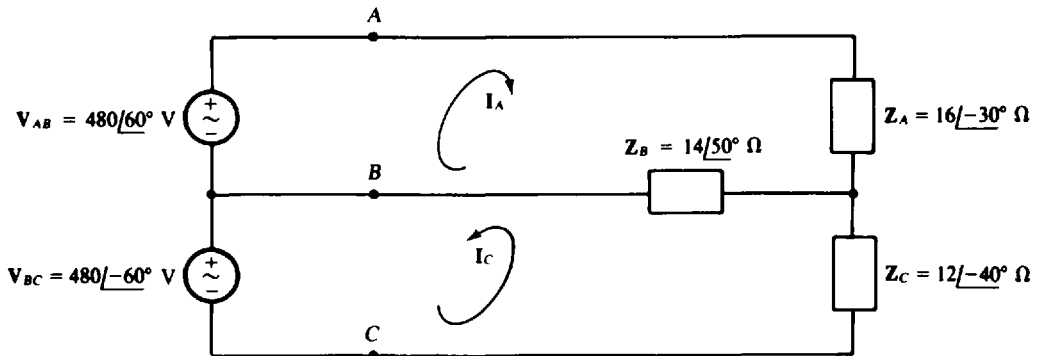

Fig. 17-16

By Cramer's rule,

$$I_A = \frac{\begin{vmatrix} 480/60^\circ & 14/50^\circ \\ -480/-60^\circ & 18.4/9.4^\circ \end{vmatrix}}{\begin{vmatrix} 23/6.8^\circ & 14/50^\circ \\ 14/50^\circ & 18.4/9.4^\circ \end{vmatrix}} = \frac{12.1 \times 10^3/36.2^\circ}{448/-9.6^\circ} = 26.9/45.8^\circ \text{ A}$$

$$I_C = \frac{\begin{vmatrix} 23/6.8^\circ & 480/60^\circ \\ 14/50^\circ & -480/-60^\circ \end{vmatrix}}{448/-9.6^\circ} = \frac{5.01 \times 10^3/149.6^\circ}{448/-9.6^\circ} = 11.2/159.2^\circ \text{ A}$$

Of course, by KCL,

$$I_B = -I_A - I_C = -26.9/45.8^\circ - 11.2/159.2^\circ = 24.7/-110^\circ \text{ A}$$

17.47 In the circuit of Fig. 17-16, include the third voltage generator V_{CA} and use PSpice to obtain the three generator currents I_{AB} , I_{BC} , and I_{CA} , as well as the line currents I_A , I_B , and I_C .

The PSpice circuit is shown in Fig. 17.17. Resistors R1, R2, and R3 of the same negligibly small resistance have been inserted to avoid having a loop of voltage sources, which PSpice will not accept. There is nothing especially significant about the node numbering or the particular choice of the 0 node. Since

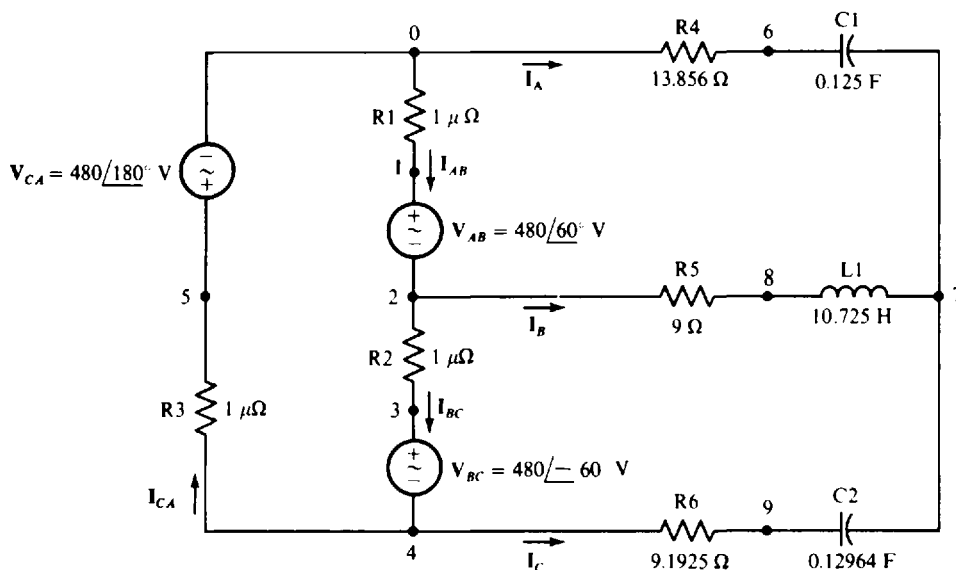

Fig. 17-17

inductances and capacitances must be specified instead of impedances, the load impedances have been converted to time-domain quantities, with the inductor and capacitor values based on a radian frequency of 1 rad/s. Then since $16/\underline{-30} \Omega = 13.856 - j8 \Omega$, the Z_A impedance is obtained with a resistor of 13.856Ω in series with a capacitor of $\frac{1}{8} = 0.125$ F. Similarly, because $14/\underline{50} \Omega = 9 + j10.725 \Omega$, the Z_B impedance is obtained with a $9\text{-}\Omega$ resistor in series with a 10.725-H inductor. And since $12/\underline{-40} \Omega = 9.1925 - j7.7135 \Omega$, the Z_C impedance is obtained with a $9.1925\text{-}\Omega$ resistor in series with a capacitor of $\frac{1}{7.7135} = 0.12964$ F capacitance.

Following is the corresponding PSpice circuit file and the output obtained when PSpice is run with this circuit file. This output, expressed in terms of the currents specified in the circuit of Fig. 17.17 are

$$\mathbf{I}_{AB} = 16.82 \underline{-122.5} \text{ A} \quad \mathbf{I}_{BC} = 9.102 \underline{94.47} \text{ A} \quad \mathbf{I}_{CA} = 11.00 \underline{27.67} \text{ A}$$

and

$$\mathbf{I}_A = 26.92 \underline{45.77} \text{ A} \quad \mathbf{I}_B = 24.70 \underline{-109.7} \text{ A} \quad \mathbf{I}_C = 11.18 \underline{159.2} \text{ A}$$

The line current values agree within three significant digits with those obtained in the solution to Prob. 17.46.

CIRCUIT FILE FOR THE CIRCUIT OF FIG. 17-17

```

R1  0 1  1U
VAB 1 2  AC  480 60
R2  2 3  1U
VBC 3 4  AC  480 -60
R3  4 5  1U
VCA 5 0  AC  480 180
R4  0 6  13.856
C1  6 7  0.125
R5  2 8  9
L1  8 7  10.725
R6  4 9  9.1925
C2  9 7  0.12964
.AC  LIN 1  0.159155  0.159155
.PRINT AC  IM(VAB)  IP(VAB)  IM(VBC)  IP(VBC)  IM(VCA)  IP(VCA)
.PRINT AC  IM(R4)   IP(R4)   IM(R5)  IP(R5)  IM(R6)  IP(R6)
.END

```

FREQ	IM(VAB)	IP(VAB)	IM(VBC)	IP(VBC)	IM(VCA)
1.592E-01	1.682E+01	-1.225E+02	9.102E+00	9.447E+01	1.100E+01

FREQ	IP(VCA)
1.592E-01	2.767E+01

FREQ	IM(R4)	IP(R4)	IM(R5)	IP(R5)	IM(R6)
1.592E-01	2.692E+01	4.577E+01	2.470E+01	-1.097E+02	1.118E+01

FREQ	IP(R6)
1.592E-01	1.592E+02

- 17.48** In the circuit shown in Fig. 17-18, in which each line has an impedance of $5 + j8 \Omega$, determine \mathbf{I}_A and \mathbf{I}_B .

The loop equations are

$$\begin{aligned} (5 + j8 + 15/\underline{-30} + 13/\underline{25} + 5 + j8)\mathbf{I}_A + (5 + j8 + 13/\underline{25})\mathbf{I}_B &= 208/\underline{40} \\ (5 + j8 + 13/\underline{25})\mathbf{I}_A + (5 + j8 + 10/\underline{45} + 13/\underline{25} + 5 + j8)\mathbf{I}_B &= -208/\underline{-80} \end{aligned}$$

In matrix form, these simplify to

$$\begin{bmatrix} 37.5/\underline{21.9} & 21.5/\underline{38.8} \\ 21.5/\underline{38.8} & 40.6/\underline{44.7} \end{bmatrix} \begin{bmatrix} \mathbf{I}_A \\ \mathbf{I}_B \end{bmatrix} = \begin{bmatrix} 208/\underline{40} \\ -208/\underline{-80} \end{bmatrix}$$

The solutions are $\mathbf{I}_A = 6.41 \underline{-9.14} \text{ A}$ and $\mathbf{I}_B = 5.11 \underline{94.1} \text{ A}$. Of course $\mathbf{I}_C = -\mathbf{I}_A - \mathbf{I}_B = 7.22 \underline{-146} \text{ A}$.

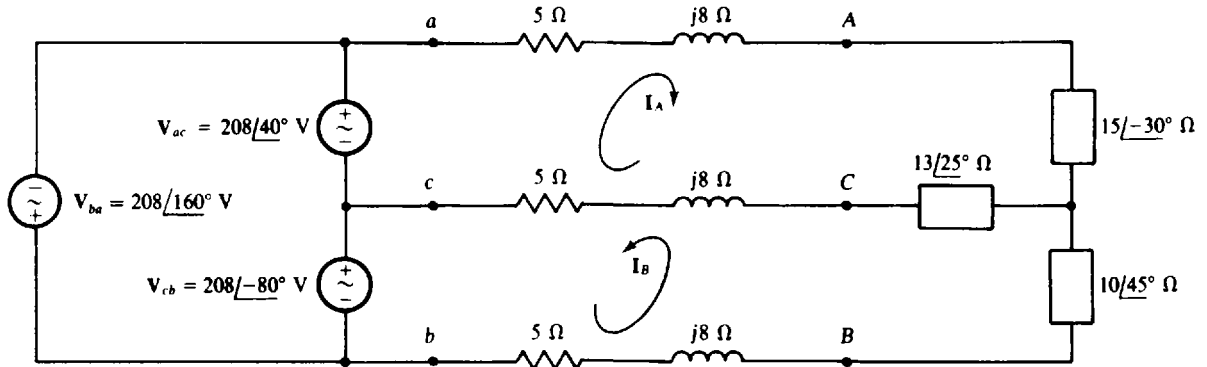

Fig. 17-18

Notice in Fig. 17-18 the use of lowercase letters at the source terminals to distinguish them from the load terminals, as is necessary because of the line impedances.

17.49 In a three-wire, *ACB* circuit in which one phase voltage at the Y-connected source is $V_{an} = 120/\underline{-30^\circ}$ V, determine the phasor line currents to a Δ load in which $Z_{AB} = 30/\underline{-40^\circ}\ \Omega$, $Z_{BC} = 40/\underline{30^\circ}\ \Omega$, and $Z_{CA} = 35/\underline{60^\circ}\ \Omega$. Each line has an impedance of $4 + j7\ \Omega$.

A good approach is to transform the Δ to a Y and then use loop analysis. The three Δ -to-Y transformation formulas have the same denominator of

$$Z_{AB} + Z_{BC} + Z_{CA} = 30/\underline{-40^\circ} + 40/\underline{30^\circ} + 35/\underline{60^\circ} = 81.3/\underline{22.4^\circ}$$

With this inserted, the transformation formulas are

$$Z_A = \frac{Z_{AB}Z_{CA}}{81.3/\underline{22.4^\circ}} = \frac{(30/\underline{-40^\circ})(35/\underline{60^\circ})}{81.3/\underline{22.4^\circ}} = \frac{1050/\underline{20^\circ}}{81.3/\underline{22.4^\circ}} = 12.9/\underline{-2.4^\circ}\ \Omega$$

$$Z_B = \frac{Z_{AB}Z_{BC}}{81.3/\underline{22.4^\circ}} = \frac{(30/\underline{-40^\circ})(40/\underline{30^\circ})}{81.3/\underline{22.4^\circ}} = \frac{1200/\underline{-10^\circ}}{81.3/\underline{22.4^\circ}} = 14.8/\underline{-32.4^\circ}\ \Omega$$

$$Z_C = \frac{Z_{CA}Z_{BC}}{81.3/\underline{22.4^\circ}} = \frac{(35/\underline{60^\circ})(40/\underline{30^\circ})}{81.3/\underline{22.4^\circ}} = \frac{1400/\underline{90^\circ}}{81.3/\underline{22.4^\circ}} = 17.2/\underline{67.6^\circ}\ \Omega$$

With the equivalent Y inserted for the Δ , the circuit is as shown in Fig. 17-19. Because of the *ACB* phase sequence, V_{bn} leads V_{an} by 120° and V_{cn} lags V_{an} by 120° , as shown.

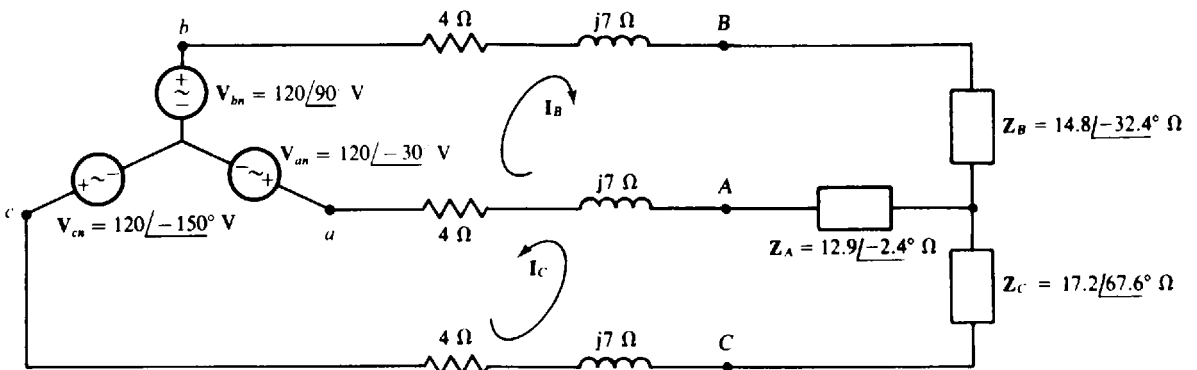

Fig. 17-19

The loop equations are

$$(4 + j7 + 14.8/\underline{-32.4^\circ} + 12.9/\underline{-2.4^\circ} + 4 + j7)\mathbf{I}_B + (4 + j7 + 12.9/\underline{-2.4^\circ})\mathbf{I}_C = 120/\underline{90^\circ} - 120/\underline{-30^\circ}$$

$$(4 + j7 + 12.9/\underline{-2.4^\circ})\mathbf{I}_B + (4 + j7 + 17.2/\underline{67.6^\circ} + 12.9/\underline{-2.4^\circ} + 4 + j7)\mathbf{I}_C = 120/\underline{-150^\circ} - 120/\underline{-30^\circ}$$

These simplify to

$$(33.8/\underline{9.41^\circ})\mathbf{I}_B + (18.1/\underline{20.9^\circ})\mathbf{I}_C = 208/\underline{120^\circ}$$

$$(18.1/\underline{20.9^\circ})\mathbf{I}_B + (40.2/\underline{46.9^\circ})\mathbf{I}_C = -208$$

The solutions are $\mathbf{I}_B = 5.4/\underline{84.2^\circ}$ A and $\mathbf{I}_C = 5.11/\underline{160^\circ}$ A. Of course $\mathbf{I}_A = -\mathbf{I}_B - \mathbf{I}_C$, from which $\mathbf{I}_A = 8.27/\underline{-58.9^\circ}$ A.

Supplementary Problems

- 17.50** What is the phase sequence of a Y-connected three-phase alternator for which $\mathbf{V}_{AN} = 7200/\underline{-130^\circ}$ V and $\mathbf{V}_{BN} = 7200/\underline{110^\circ}$ V? Also, what is \mathbf{V}_{CN} ?
- Ans.* ABC , $\mathbf{V}_{CN} = 7200/\underline{-10^\circ}$ V
- 17.51** Find the phase sequence of a balanced three-phase circuit in which $\mathbf{V}_{AN} = 120/\underline{15^\circ}$ V and $\mathbf{V}_{CN} = 120/\underline{135^\circ}$ V. Also, find \mathbf{V}_{BN} .
- Ans.* ABC , $\mathbf{V}_{BN} = 120/\underline{-105^\circ}$ V
- 17.52** For a three-phase, three-wire circuit, find the phasor line currents to a balanced Y load in which each phase impedance is $30/\underline{-40^\circ}$ Ω and for which $\mathbf{V}_{CN} = 277/\underline{-70^\circ}$ V. The phase sequence is ACB .
- Ans.* $\mathbf{I}_A = 9.23/\underline{90^\circ}$ A, $\mathbf{I}_B = 9.23/\underline{-150^\circ}$ A, $\mathbf{I}_C = 9.23/\underline{-30^\circ}$ A
- 17.53** Find the phase sequence of a three-phase circuit in which $\mathbf{V}_{BA} = 12\,470/\underline{-140^\circ}$ V and $\mathbf{V}_{AC} = 12\,470/\underline{100^\circ}$ V. Also, find the third line voltage.
- Ans.* ACB , $\mathbf{V}_{CB} = 12\,470/\underline{-20^\circ}$ V
- 17.54** What is the phase sequence of a three-phase circuit for which $\mathbf{V}_{BN} = 7.62/\underline{-45^\circ}$ kV and $\mathbf{V}_{CB} = 13.2/\underline{105^\circ}$ kV?
- Ans.* ACB
- 17.55** A balanced Y load has one phase voltage of $\mathbf{V}_{BN} = 120/\underline{130^\circ}$ V. If the phase sequence is ABC , find the line voltages \mathbf{V}_{AC} , \mathbf{V}_{CB} , and \mathbf{V}_{BA} .
- Ans.* $\mathbf{V}_{AC} = 208/\underline{-140^\circ}$ V, $\mathbf{V}_{CB} = 208/\underline{-20^\circ}$ V, $\mathbf{V}_{BA} = 208/\underline{100^\circ}$ V
- 17.56** What are the phase voltages for a balanced three-phase Y load if $\mathbf{V}_{CA} = 208/\underline{-125^\circ}$ V? The phase sequence is ACB .
- Ans.* $\mathbf{V}_{AN} = 120/\underline{25^\circ}$ V, $\mathbf{V}_{BN} = 120/\underline{145^\circ}$ V, $\mathbf{V}_{CN} = 120/\underline{-95^\circ}$ V
- 17.57** A balanced three-wire, ACB circuit has one line current of $\mathbf{I}_C = 6/\underline{-10^\circ}$ A. Find the other line currents.
- Ans.* $\mathbf{I}_A = 6/\underline{110^\circ}$ A, $\mathbf{I}_B = 6/\underline{-130^\circ}$ A
- 17.58** Find the \mathbf{I}_C line current in an unbalanced three-wire, three-phase circuit in which $\mathbf{I}_A = 6/\underline{-30^\circ}$ A and $\mathbf{I}_B = -4/\underline{50^\circ}$ A.
- Ans.* $\mathbf{I}_C = 6.61/\underline{113^\circ}$ A.

- 17.59** A balanced Y load of $100\text{-}\Omega$ resistors is connected to a 208-V, three-phase, three-wire source. Find the rms line current.
Ans. 1.2 A
- 17.60** A balanced Y load of $40/60\text{-}\Omega$ impedances is connected to a 600-V, three-phase, three-wire source. Find the rms line current.
Ans. 8.66 A
- 17.61** Find the phasor line currents to a balanced Y load of $45/-48\text{-}\Omega$ impedances. One phase voltage is $V_{CN} = 120/-65^\circ$ V, the phase sequence is *ACB*, and there are only three wires.
Ans. $I_A = 2.67/103^\circ$ A, $I_B = 2.67/-137^\circ$ A, $I_C = 2.67/-17^\circ$ A
- 17.62** For a three-phase, three-wire circuit, find the phasor line currents to a balanced three-phase Y load of $80/25\text{-}\Omega$ impedances if $V_{AB} = 600/-30^\circ$ V and the phase sequence is *ACB*.
Ans. $I_A = 4.33/-25^\circ$ A, $I_B = 4.33/95^\circ$ A, $I_C = 4.33/-145^\circ$ A
- 17.63** Find the phase sequence of a three-phase circuit in which two of the phase currents of a balanced Δ load are $I_{AB} = 10/50^\circ$ A and $I_{CA} = 10/170^\circ$ A. Also, find the third phase current.
Ans. *ABC*, $I_{BC} = 10/-70^\circ$ A
- 17.64** Find the phase currents I_{AC} , I_{CB} , and I_{BA} of a balanced three-phase Δ load to which one line current is $I_A = 1.4/65^\circ$ A. The phase sequence is *ACB*.
Ans. $I_{AC} = 0.808/95^\circ$ A, $I_{CB} = 0.808/-25^\circ$ A, $I_{BA} = 0.808/-145^\circ$ A
- 17.65** A balanced three-phase Δ load has one phase current of $I_{CA} = 4/-35^\circ$ A. If the phase sequence is *ABC*, find the phasor line currents and the other phasor phase currents.
Ans. $I_A = 6.93/175^\circ$ A $I_{AB} = 4/-155^\circ$ A
 $I_B = 6.93/55^\circ$ A $I_{BC} = 4/85^\circ$ A
 $I_C = 6.93/-65^\circ$ A
- 17.66** Find the phasor line currents to a balanced three-phase Δ load in which one phase current is $I_{BA} = 4.2/-30^\circ$ A. The phase sequence is *ACB*.
Ans. $I_A = -7.27$ A, $I_B = 7.27/-60^\circ$ A, $I_C = 7.27/60^\circ$ A
- 17.67** Find the rms value of the line currents to a balanced Δ load of $100\text{-}\Omega$ resistors from a 480-V, three-phase, three-wire source.
Ans. 8.31 A
- 17.68** Find the phasor line currents to a balanced three-phase Δ load of $200/-55\text{-}\Omega$ impedances if the phase sequence is *ABC* and if one phase voltage is $V_{CA} = 208/-60^\circ$ V.
Ans. $I_A = 1.8/-155^\circ$ A, $I_B = 1.8/85^\circ$ A, $I_C = 1.8/-35^\circ$ A
- 17.69** A balanced Δ load of $50/35\text{-}\Omega$ impedances is energized from the Y-connected secondary of a three-phase transformer for which $V_{AN} = 120/-10^\circ$ V. If the phase sequence is *ABC*, find the phasor line and load currents.
Ans. $I_A = 7.2/-45^\circ$ A $I_{AC} = 4.16/-75^\circ$ A
 $I_B = 7.2/-165^\circ$ A $I_{BC} = 4.16/-195^\circ$ A
 $I_C = 7.2/75^\circ$ A $I_{CB} = 4.16/45^\circ$ A

- 17.70** A balanced Y load with impedances of $8 + j6 \Omega$ is connected to a three-phase source by three wires, each of which has $3 + j4 \Omega$ of impedance. The rms load phase voltage is 50 V. Find the rms line voltage at the source.
Ans. 129 V
- 17.71** A balanced Δ load with impedances of $15 - j9 \Omega$ is connected to a three-phase source by three wires, each of which has $2 + j5 \Omega$ of impedance. The rms load phase voltage is 120 V. Find the rms line voltage at the source.
Ans. 150 V
- 17.72** A 600-V, three-phase, three-wire circuit has two parallel-connected balanced Δ loads, one of 30- Ω resistors and the other of 60- Ω resistors. Find the total rms line current.
Ans. 52 A
- 17.73** A 480-V, three-phase, three-wire circuit has two parallel-connected balanced Y loads, one of 40- Ω resistors and the other of 120- Ω resistors. Find the total rms line current.
Ans. 9.24 A
- 17.74** A 480-V three-phase circuit has two parallel-connected balanced Δ loads, one of $50 \angle 60^\circ \Omega$ impedances and the other of $70 \angle 50^\circ \Omega$ impedances. Find the total rms line current and the total average power absorbed.
Ans. 16.8 A, 13.3 kW
- 17.75** A 600-V three-phase circuit has two parallel-connected balanced loads, one a Δ of $90 \angle 40^\circ \Omega$ impedances and the other a Y of $50 \angle 30^\circ \Omega$ impedances. Find the total rms line current and the total average power absorbed.
Ans. 15.4 A, 15.4 kW
- 17.76** A balanced Y load of $30 \angle 30^\circ \Omega$ impedances and a parallel-connected balanced Δ load of $90 \angle -50^\circ \Omega$ impedances are connected by three wires to the secondary of a three-phase transformer. If $V_{BA} = 208 \angle -30^\circ$ V and the phase sequence is ACB, find the total phasor line currents.
Ans. $I_A = 7.88 \angle -140^\circ$ A, $I_B = 7.88 \angle -20^\circ$ A, $I_C = 7.88 \angle 100^\circ$ A
- 17.77** A balanced Δ load of $60 \angle 50^\circ \Omega$ impedances is connected to the secondary of a three-phase transformer by three wires that have $3 + j4 \Omega$ of impedance each. If the rms line voltage is 480 V at the secondary terminals, find the rms line current.
Ans. 11.1 A
- 17.78** Find the average power absorbed by a balanced three-phase load in an ACB circuit in which one line voltage is $V_{AC} = 480 \angle 30^\circ$ V and one line current to the load is $I_B = 2.1 \angle 80^\circ$ A.
Ans. 1.34 kW
- 17.79** A three-phase induction motor delivers 100 hp while operating at an 80 percent efficiency and a 0.7 lagging power factor from 600-V lines. Find the rms line current.
Ans. 128 A
- 17.80** A three-phase induction motor delivers 150 hp while operating at an efficiency of 75 percent and a power factor of 0.8 lagging from 480-V lines. A Y bank of power factor correction capacitors is to be inserted to improve the overall power factor to 0.9 lagging. Determine the capacitance required per phase.
Ans. 456 μ F
- 17.81** In a 480-V three-phase circuit, a balanced Δ load absorbs 5 kW at a 0.7 lagging power factor. Find the Δ phase impedance.
Ans. $96.8 \angle 45.6^\circ \Omega$

- 17.82** Given that $V_{AC} = 208\angle -40^\circ$ V in an ACB three-phase circuit, find the phasor line currents to a balanced load that absorbs 10 kW at a 0.8 lagging power factor.
Ans. $I_A = 34.7\angle -107^\circ$ A, $I_B = 34.7\angle 13^\circ$ A, $I_C = 34.7\angle 133^\circ$ A
- 17.83** A 600-V three-phase circuit has two parallel-connected balanced loads. One is a synchronous motor that delivers 30 hp while operating at an 85 percent efficiency and a 0.7 leading power factor. The other is an induction motor that delivers 50 hp while operating at an 80 percent efficiency and a 0.85 lagging power factor. Find the total rms line current.
Ans. 70.2 A
- 17.84** If $I_B = 20\angle 40^\circ$ A, $I_C = 15\angle -30^\circ$ A, and $V_{BC} = 480\angle -40^\circ$ V in a three-wire, ACB circuit, find the reading of a wattmeter connected with its current coil in line A and its potential coil across lines A and B . The \pm terminal of the current coil is toward the source, and the \pm terminal of the potential coil is at line A .
Ans. 13.6 kW
- 17.85** A balanced Y load of $50\text{-}\Omega$ resistors is connected to a 208-V, ACB , three-wire, three-phase source. Find the reading of a wattmeter connected with its current coil in line B and its potential coil across lines A and C . The \pm terminal of the current coil is toward the source, and the \pm terminal of the potential coil is at line A .
Ans. 0 W
- 17.86** A balanced Δ load with impedances of $9 + j12\ \Omega$ is connected to a 480-V, ABC source. Find the reading of a wattmeter connected with its current coil in line A and its potential coil across lines B and C . The \pm terminal of the current coil is toward the source, and the \pm terminal of the potential coil is at line C .
Ans. -21.3 kW
- 17.87** A 600-V three-phase circuit has a balanced Y load of $40\angle 30^\circ\text{-}\Omega$ impedances. Find the wattmeter readings for the two-wattmeter method.
Ans. 5.2 kW, 2.6 kW
- 17.88** A 480-V, ACB circuit has a balanced Y load of $30\angle -50^\circ\text{-}\Omega$ impedances. Two wattmeters are connected for the two-wattmeter method with current coils in lines B and C . Find the wattmeter readings.
Ans. $P_B = 4.17$ kW, $P_C = 770$ W
- 17.89** A 600-V, ACB circuit has a balanced Δ load of $60\angle 20^\circ\text{-}\Omega$ impedances. Two wattmeters are connected for the two-wattmeter method with current coils in lines B and C . Find the wattmeter readings.
Ans. $P_B = 6.68$ kW, $P_C = 10.2$ kW
- 17.90** A balanced Y load is connected to a 208-V three-phase source. The two-wattmeter method is used to measure the average power absorbed by the load. If the wattmeter readings are 8 kW and 4 kW, find the Y phase impedance.
Ans. Either $3.12\angle 30^\circ\ \Omega$ or $3.12\angle -30^\circ\ \Omega$
- 17.91** Two wattmeters both have readings of 5 kW when connected for the two-wattmeter method in a 480-V three-phase circuit that has a balanced Δ load. Find the Δ phase impedance.
Ans. $69.1\angle 0^\circ\ \Omega$
- 17.92** Two wattmeters are connected for the two-wattmeter method with current coils in lines A and B of a 208-V, ABC circuit that has a balanced Δ load. If the wattmeter readings are 6 kW and -3 kW, respectively, find the Δ phase impedance.
Ans. $8.18\angle 79.1^\circ\ \Omega$

- 17.93** Two wattmeters are connected for the two-wattmeter method with current coils in lines B and C of a 600-V, ABC circuit that has a balanced Y load. Find the Y phase impedance if the two wattmeter readings are 3 kW and 10 kW, respectively.
- Ans.* $20.3/\underline{-43^\circ} \Omega$
- 17.94** A 480-V, ACB circuit has an unbalanced Δ load consisting of resistors $R_{AC} = 60 \Omega$, $R_{BA} = 85 \Omega$, and $R_{CB} = 70 \Omega$. Two wattmeters are connected for the two-wattmeter method with current coils in lines A and C . What are the wattmeter readings?
- Ans.* $P_A = 4.63 \text{ kW}$, $P_C = 5.21 \text{ kW}$
- 17.95** For a four-wire, ABC circuit in which $V_{BN} = 208/\underline{65^\circ} \text{ V}$, find the four phasor line currents to a Y load of $Z_A = 30/\underline{-50^\circ} \Omega$, $Z_B = 25/\underline{38^\circ} \Omega$, and $Z_C = 35/\underline{-65^\circ} \Omega$.
- Ans.* $I_A = 6.93/\underline{-125^\circ} \text{ A}$, $I_B = 8.32/\underline{27^\circ} \text{ A}$, $I_C = 5.94/\underline{10^\circ} \text{ A}$, $I_N = 9.33/\underline{175^\circ} \text{ A}$
- 17.96** For an ACB circuit in which $V_{AC} = 600/\underline{-15^\circ} \text{ V}$, find the phasor line currents to a Δ load of $Z_{AC} = 150/\underline{-35^\circ} \Omega$, $Z_{BA} = 200/\underline{60^\circ} \Omega$, and $Z_{CB} = 175/\underline{-70^\circ} \Omega$.
- Ans.* $I_A = 1.8/\underline{-24.7^\circ} \text{ A}$, $I_B = 5.27/\underline{82.7^\circ} \text{ A}$, $I_C = 5.04/\underline{-117^\circ} \text{ A}$
- 17.97** In a three-wire, ACB circuit in which $V_{CB} = 208/\underline{-40^\circ} \text{ V}$, find the phasor line currents to a Y load of $Z_A = 10/\underline{30^\circ} \Omega$, $Z_B = 20/\underline{60^\circ} \Omega$, and $Z_C = 15/\underline{-50^\circ} \Omega$.
- Ans.* $I_A = 2.53/\underline{88.8^\circ} \text{ A}$, $I_B = 10.7/\underline{133^\circ} \text{ A}$, $I_C = 12.6/\underline{-54.8^\circ} \text{ A}$
- 17.98** In a three-wire, ACB circuit in which one source line voltage is $V_{bc} = 480/\underline{-30^\circ} \text{ V}$, find the phasor line currents to a Y load of $Z_A = 12/\underline{60^\circ} \Omega$, $Z_B = 8/\underline{20^\circ} \Omega$, and $Z_C = 10/\underline{-30^\circ} \Omega$. Each line has an impedance of $3 + j4 \Omega$.
- Ans.* $I_A = 15.2/\underline{-165^\circ} \text{ A}$, $I_B = 27.3/\underline{-33.9^\circ} \text{ A}$, $I_C = 20.9/\underline{113^\circ} \text{ A}$
- 17.99** In a three-wire, ABC circuit in which one source line voltage is $V_{ab} = 480/\underline{60^\circ} \text{ V}$, find the phasor line currents to a Δ load of $Z_{AB} = 40/\underline{-50^\circ} \Omega$, $Z_{BC} = 35/\underline{60^\circ} \Omega$, and $Z_{CA} = 50/\underline{40^\circ} \Omega$. Each line has an impedance of $8 + j9 \Omega$.
- Ans.* $I_A = 7.44/\underline{27.8^\circ} \text{ A}$, $I_B = 14/\underline{-112^\circ} \text{ A}$, $I_C = 9.64/\underline{97.8^\circ} \text{ A}$
- 17.100** Determine the answers that will be printed in the output file when PSpice is run with the following circuit file.

```

CIRCUIT FILE FOR PROB. 17.100
V1      1  0  AC  340  90
V2      2  0  AC  340 -30
V3      3  0  AC  340 -150
R1      1  4  1
L1      4  5  1
R2      2  6  1
L2      6  7  1
R3      3  8  1
L3      8  9  1
R4      5 10  6
C1     10  7  66.667M
R5      7 11  6
C2     11  9  66.667M
R6      9 12  6
C3     12  5  66.667M
.AC LIN 1 0.159155 0.159155
.PRINT AC VM(5) VP(5) IM(R4) IP(R4)
.END

```

Ans. $366.2/\underline{74.93^\circ} \text{ V}$, $39.26/\underline{173.1^\circ} \text{ A}$

Index

- ac (alternating current), 3, 194
- ac circuit, 194
- ac generator (alternator), 195, 384
- ac PSpice analysis, 268–269
- Admittance, 238
 - conductance of, 238
 - mutual, 267
 - self-, 267
 - susceptance of, 238
- Admittance diagram, 238
- Admittance triangle, 238
- Air-core transformer, 352
- Algebra, complex, 217–221
- Alternating current (ac), 3, 194
- Alternating current circuit, 194
- Alternator (ac generator), 195, 384
- Ampere, 2
- Analysis:
 - loop, 57, 266
 - mesh, 56, 265
 - nodal, 58, 267
- Angle, phase, 197
- Angular frequency, 195
- Angular velocity, 195
- Apparent power, 327
- Associated references, 5
- Autotransformer, 354
- Average power, 194, 324
- Average value of periodic wave, 198

- Balanced bridge, 87, 297
- Balanced three-phase load, 387, 389
- Branch, 31
- Bridge balance equation, 87, 297
- Bridge circuit, 86
 - capacitance comparison, 316
 - Maxwell, 317
 - Wheatstone, 86
- Buffer, 116

- Capacitance, 153
 - equivalent, 154
 - total, 154
- Capacitance comparison bridge, 316
- Capacitive circuit, 235
- Capacitive reactance, 200
- Capacitor, 153
 - energy stored, 155
 - sinusoidal response, 200
- Cascaded op amps, 116

- Charge, 1
 - conservation of, 2
 - electron, 1
 - proton, 1
- Choke, 175
- Circuit, 2
 - ac, 194
 - capacitive, 235
 - dc, 31
 - inductive, 235
 - phasor-domain, 232
 - three-phase, 384–414
 - time-domain, 232
- Coefficient of coupling, 353
- Coil, 175
- Color code, resistor, 20
- Complex algebra, 217–221
- Complex number:
 - angle, 219
 - conjugate, 219
 - exponential form, 219
 - magnitude, 219
 - polar form, 219
 - rectangular form, 218
- Complex plane, 218
- Complex power, 326
- Conductance, 17
 - of admittance, 238
 - equivalent, 33
 - mutual, 58
 - self-, 58
 - total, 33
- Conductivity, 18
- Conductor, 17
- Conjugate, 219
- Conservation of charge, 2
- Controlled source, 4
- Conventional current flow direction, 2
- Cosine wave, 197
- Coulomb, 2
- Coupled impedance, 354
- Coupling, coefficient of, 353
- Cramer's rule, 54
- Current, 2
 - ac, 3, 194
 - dc, 3
 - loop, 57
 - mesh, 56
 - phase, 386
 - short-circuit, 83, 295
- Current direction, 2
 - reference, 2

- Current division rule, 34, 239
- Current source, 3
 - controlled, 4
 - dependent, 4
 - independent, 4
 - Norton, 83, 295
- Cycle, 194

- dc (direct current), 3
- dc circuit, 31
- dc PSpice analysis, 136–140
- dc source, 4
- Delta (Δ) connection, 85, 296, 386
- Δ -Y transformation, 85, 296
- Dependent source, 4
 - PSpice, 138
- Derivative, 155
- Determinant, 54
- Dielectric, 153
- Dielectric constant, 154
- Digit grouping, 1
- Direct current (dc), 3
- Direct current circuit, 31
- Direction, current, 2
- Dot convention, 350
- Double-subscript notation, 3, 384
- Drop, voltage, 3
- Dual, 72

- Effective value, 198
- Efficiency, 5
- Electron, 1
- Electron charge, 2
- Energy, 3, 5
 - stored by a capacitor, 155
 - stored by an inductor, 177
- Equivalent circuit:
 - Norton's, 83, 295
 - Thévenin's, 82, 294
- Equivalent sources, 56, 265
- Euler's identity, 219
- Exponential form of complex number, 219

- Farad, 153
- Faraday's law, 175
- Ferromagnetic material, 174
- Flux:
 - leakage, 350
 - magnetic, 174, 349
 - mutual, 349
- Flux linkage, 175
- Frequency, 194
 - angular, 195
 - radian, 195

- General transformer equation, 358
- Generator:
 - ac, 195, 384
 - Δ -connected, 386
 - Y-connected, 385
- Giga-, 2
- Ground, 33
- Grouping of digits, 1

- Henry, 175
- Hertz, 194
- Horsepower, 5

- Ideal transformer, 350
- Imaginary number, 217
- Impedance, 234
 - coupled, 354
 - equivalent, 234
 - input, 235
 - mutual, 266
 - output, 303
 - reactance of, 235
 - reflected, 351, 354
 - resistance of, 235
 - self-, 266
 - Thévenin, 294
 - total, 234
- Impedance angle, 235
- Impedance diagram, 235
- Impedance plane, 235
- Impedance triangle, 236
- Independent source, 4
- Induced voltage, 175, 353
- Inductance, 175
 - equivalent, 176
 - mutual, 353
 - self-, 353
 - total, 176
- Inductive circuit, 235
- Inductive reactance, 199
- Inductor, 175
 - energy stored, 177
 - sinusoidal response, 199
- Inferred zero resistance temperature, 18
- Input impedance, 235
- Input resistance, 84
- Instantaneous current, 155
- Instantaneous power, 198, 324
- Instantaneous voltage, 155
- Insulator, 17
- Internal resistance, 20
- International System of Units (SI), 1
- Inverter, 114
- Ion, 2
- Iron-core transformer, 350

- Joule, 3
- Kilo-, 2
- Kilohm-milliampere method, 34
- Kilowatthour, 5
- Kirchhoff's laws:
 - current law (KCL), 32, 267
 - voltage law (KVL), 31, 265
- Lagging power factor, 325
- Lattice circuit, 86
- Leading power factor, 325
- Leakage flux, 350
- Line current, 386
- Line voltage, 386
- Linear circuit, 82
- Linear circuit element, 82
- Linear transformer, 352
- Load:
 - balanced, 387, 389
 - Δ -connected, 85, 296, 389
 - parallel three-phase, 390
 - unbalanced, 393
 - Y-connected, 85, 296, 387
- "Long time," 165
- Loop, 31
- Loop analysis, 57, 266
- Loop current, 57
- Magnetic flux, 174
- Matching, resistance, 84, 359
- Maximum power transfer theorem, 84, 295
- Maxwell bridge, 317
- Mega-, 2
- Mesh, 31
- Mesh analysis, 56, 265
- Mesh current, 56
- Mho, 17
- Micro-, 2
- Milli-, 2
- Millman's theorem, 84
- Model:
 - op amp, 112
 - PSpice op-amp, 139
 - transformer, 350
- Mutual admittance, 267
- Mutual conductance, 58
- Mutual flux, 349
- Mutual impedance, 266
- Mutual inductance, 353
- Mutual resistance, 57
- Nano-, 2
- Negative charge, 1
- Negative phase sequence, 386
- Network (*see* Circuit)
- Network theorem (*see* Theorem)
- Neutral, 386
- Neutron, 2
- Newton, 3
- Nodal analysis, 58, 267
- Node, 31
 - reference, 33
- Node voltage, 33
- Nominal value of resistance, 19
- Noninverting voltage amplifier, 115
- Norton's theorem, 83, 295
- Ohm, 17
- Ohm's law, 17
- Op amp: (*see* Operational amplifier)
- Open circuit, 20
- Open-circuit voltage, 82, 294
- Operational amplifier (op amp), 112
 - model, 112
 - open-loop voltage gain, 112
 - PSpice model, 139
- Operational-amplifier circuits, 112-135
 - buffer, 116
 - cascaded op amps, 116
 - inverter, 114
 - noninverting voltage amplifier, 115
 - voltage follower, 116
 - voltage-to-current converter, 116
- Oscillator, 157
- Output impedance, 303
- Output resistance, 82, 84
- Parallel connection, 21, 31
- Passive sign convention, 5
- Period, 158, 194
- Periodic quantity, 194
 - effective value, 198
- Permeability, 174
- Permittivity, 154
- Phase angle, 197
- Phase current, 386
- Phase difference, 197
- Phase relation, 197
- Phase sequence, 386
- Phase voltage, 386
- Phasor, 221
- Phasor diagram, 221
- Phasor-domain circuit, 232
- Pico-, 2
- Plane, complex, 218
- Polar form of complex number, 219
- Polarity, reference voltage, 4
- Polarity, voltage, 3
- Positive charge, 1
- Positive phase sequence, 386

- Potential drop, 3
- Potential rise, 3
- Power, 5, 324
 - apparent, 327
 - average, 194, 324
 - complex, 326
 - instantaneous, 198, 324
 - maximum transfer of, 84, 295
 - reactive, 326
 - real, 326
 - resistor, 19
 - three-phase, 391
- Power factor, 324
 - lagging, 325
 - leading, 325
- Power factor angle, 324
- Power factor correction, 327
- Power measurement:
 - single-phase, 325
 - three-phase, 391
 - two-wattmeter method, 334, 392
- Power triangle, 326
- Primary winding, 349
- Probe, 178
- Proton, 1
- PSpice analysis:
 - ac, 268–269
 - dc, 136–140
 - Probe, 178
 - transient, 177–179
 - three-phase circuits, 393
 - transformer circuits, 356

- Radian, 195
- Radian frequency, 195
- Rationalizing, 218, 219
- RC time constant, 156
- RC timer, 157
- Reactance:
 - capacitive, 200
 - of impedance, 235
 - inductive, 199
- Reactive factor, 326
- Reactive power, 326
- Real number, 217
- Rectangular form of complex number, 218
- Reference current direction, 2
- Reference node, 33
- Reference voltage polarity, 4
- References, associated, 5
- Reflected impedance, 351, 354
- Relative permeability, 175
- Relative permittivity, 154
- Resistance, 17
 - equivalent, 31
 - of impedance, 235
- Resistance (*cont.*):
 - input, 84
 - internal, 20
 - mutual, 57
 - nominal value, 19
 - output, 82, 84
 - self-, 57
 - Thévenin, 82
 - tolerance, 19
 - total, 31
- Resistance matching, 84, 359
- Resistivity, 17
- Resistor, 19
 - color code, 20
 - linear, 19
 - nonlinear, 19
 - sinusoidal response, 198
- Resonant frequency, 240
- Right-hand rule, 174, 349
- Rise, voltage, 3
- RL time constant, 177
- rms (root-mean-square) value, 199

- Secondary winding, 349
- Self-admittance, 267
- Self-conductance, 58
- Self-impedance, 266
- Self-inductance, 353
- Self-resistance, 57
- Semiconductor, 18
- Series connection, 21, 31
- Short circuit, 20
- Short-circuit current, 83, 295
- SI (International System of Units), 1
- Siemens, 17
- Sine wave, 194, 195
- Sinusoid, 197
 - average value, 198
 - effective value, 199
- Source:
 - ac, 194, 384
 - controlled, 4
 - current, 3
 - dc, 4
 - dependent, 4
 - equivalent, 56, 265
 - independent, 4
 - Norton, 83, 295
 - practical, 20
 - Thévenin, 82, 294
 - voltage, 4
- Source transformation, 56, 265
- SPICE program, 136
- Step-down transformer, 351
- Step-up transformer, 351
- Subscript notation:
 - current, 384

- Subscript notation (*cont.*):
 - voltage, 3, 384
- Superposition theorem, 84, 295
- Susceptance, 238

- Temperature coefficient of resistance, 19
- Tera-, 2
- Theorem:
 - maximum power transfer, 84, 295
 - Millman's, 84
 - Norton's, 83, 295
 - superposition, 84, 295
 - Thévenin's, 82, 294
- Thévenin's theorem, 82, 294
- Three-phase circuits, 384–414
 - balanced, 384, 387, 389
 - PSpice analysis, 393
 - unbalanced, 393
- Three-phase power, 391
- Three-phase power measurement, 391
- Time constant, 156
 - RC, 156
 - RL, 177
- Time-domain circuit, 232
- Time-varying voltages and currents, 155
- Timer, RC, 157
- Tolerance, resistance, 19
- Transformation:
 - Δ -Y, 85, 296
 - source 56, 265
- Transformation ratio, 350
- Transformers, 349–383
 - air-core, 352
 - ideal, 350
 - iron-core, 350
 - linear, 352
 - PSpice models, 356
 - step-down, 351
 - step-up, 351
- Transient, 156
- Transient PSpice analysis, 177–179
- Turns ratio, 350
- Two-wattmeter method, 334, 392

- Unbalanced three-phase circuit, 393
- Unit symbol, 1
- Units, SI, 1

- VAR, 326
- Volt, 3
- Voltage, 3
 - induced, 175, 353
 - node, 33
 - open-circuit, 82, 294
 - phase, 386
- Voltage difference, 3
- Voltage division rule, 32, 236
- Voltage drop, 3
- Voltage follower, 116
- Voltage polarity, 3
 - reference, 4
- Voltage rise, 3
- Voltage source, 4
 - controlled, 4
 - dependent, 4
 - independent, 4
 - Thévenin, 82, 294
- Voltage-to-current converter, 116
- Voltampere, 326
- Voltampere reactive, 326

- Watt, 5
- Wattmeter, 325
- Weber, 174
- Wheatstone bridge, 86
- Winding:
 - primary, 349
 - secondary, 349
- Work, 3

- Y (Wye) connection, 85, 296, 385
- Y- Δ transformation, 85, 296

This page intentionally left blank

SCHAUM'S INTERACTIVE OUTLINE SERIES

Schaum's Outlines and MathcadTM Combined...
The Ultimate Solution.

NOW AVAILABLE! Electronic, interactive versions of engineering titles from the Schaum's Outline Series:

- *Electric Circuits*
- *Electromagnetics*
- *Feedback and Control Systems*
- *Thermodynamics For Engineers*
- *Fluid Mechanics and Hydraulics*

McGraw-Hill has joined with MathSoft, Inc., makers of Mathcad, the world's leading technical calculation software, to offer you interactive versions of popular engineering titles from the Schaum's Outline Series. Designed for students, educators, and technical professionals, the *Interactive Outlines* provide comprehensive on-screen access to theory and approximately 100 representative solved problems. Hyperlinked cross-references and an electronic search feature make it easy to find related topics. In each electronic outline, you will find all related text, diagrams and equations for a particular solved problem together on your computer screen. Every number, formula and graph is interactive, allowing you to easily experiment with the problem parameters, or adapt a problem to solve related problems. The *Interactive Outline* does all the calculating, graphing and unit analysis for you.

These "live" *Interactive Outlines* are designed to help you learn the subject matter and gain a more complete, more intuitive understanding of the concepts underlying the problems. They make your problem solving easier, with power to quickly do a wide range of technical calculations. All the formulas needed to solve the problem appear in real math notation, and use Mathcad's wide range of built in functions, units, and graphing features. This interactive format should make learning the subject matter easier, more effective and even fun.

For more information about *Schaum's Interactive Outlines* listed above and other titles in the series, please contact

Schaum Division
McGraw-Hill, Inc.
1221 Avenue of the Americas
New York, New York 10020
Phone: 1-800-338-3987

To place an order, please mail the coupon below to the above address or call the 800 number.

Schaum's Interactive Outline Series using *Mathcad*[®]

(Software requires 80386/80486 PC or compatibles, with Windows 3.1 or higher, 4 MB of RAM, 4 MB of hard disk space, and 3 1/2" disk drive.)

<u>AUTHOR/TITLE</u>	<u>Interactive Software Only</u> (\$29.95 ea)	<u>Quantity Ordered</u>	<u>Software and Printed Outline</u> (\$38.95 ea)	<u>Quantity Ordered</u>
	<u>ISBN</u>		<u>ISBN</u>	
MathSoft, Inc./DiStefano: Feedback & Control Systems	07-842708-8	_____	07-842709-6	_____
MathSoft, Inc./Edminister: Electric Circuits	07-842710-x	_____	07-842711-8	_____
MathSoft, Inc./Edminister: Electromagnetics	07-842712-6	_____	07-842713-4	_____
MathSoft, Inc./Giles: Fluid Mechanics & Hydraulics	07-842714-2	_____	07-842715-0	_____
MathSoft, Inc./Potter: Thermodynamics For Engineers	07-842716-9	_____	07-842717-7	_____

NAME _____ ADDRESS _____

CITY _____ STATE _____ ZIP _____

ENCLOSED IS A CHECK MASTERCARD VISA AMEX (✓ ONE)

ACCOUNT # _____ EXP. DATE _____

SIGNATURE _____

MAKE CHECKS PAYABLE TO MCGRAW-HILL, INC. PLEASE INCLUDE LOCAL SALES TAX AND \$1.25 SHIPPING/HANDLING

Free Software

Pspice is a circuit simulator software package used to calculate the behavior of electrical circuits. Class instructors can receive complimentary evaluation versions for *both* the IBM-PC and Macintosh by submitting a request on company or educational letterhead to:

MicroSim Corporation
20 Fairbanks
Irvine, CA 92718
ATTN: Product Marketing Dept.

Duplication of the diskettes for your students is encouraged.