

# **WAVES, OPTICS AND MODERN PHYSICS**

## **A COURSE MATERIAL FOR PHY105**

**T.A. OTUNLA  
(Ph.D)**

**Physics Department  
University of Ibadan**

## **GENERAL INTRODUCTION AND COURSE OBJECTIVE**

Basic principles of Waves, Optics and Modern Physics are introduced in this text as they are taught in faculty of science, University of Ibadan. The topics that are covered under the course title are a quarter of all the topics that are taught at the 100 level.

The course starts by introducing the phenomena of waves: travelling and stationary. The concept of optics was introduced using appropriate ray diagrams. The ever-evolving models of atom were used to launch the topics that were covered under modern Physics. We concluded with the scintillating concepts of radioactivity. Various illustrations with the aids of diagrams, worked examples, practice exercises and applications were employed to explain the concepts and captivate the interest of all would be users of the text. My hope is that all our students will find the text useful, interesting, and comprehensive.

### **Course Curriculum Contents**

Types and properties of waves as applied to sound and light. Doppler effect. Superposition of waves, reflection and refraction of waves at plane and curved boundaries. Propagation of sound in gases, liquids and solids, and their properties. Optical refraction of light at plane and curved surfaces. Lens maker's formula. Properties of images formed by lenses. Application of lenses in optical instruments e.g. microscope, telescope, etc. Aberrations, polarization, interference, dispersion of light and light spectrum analysis.

The atomic structure, isotope, radioactivity, cathode ray and x-ray tubes.

3 Units, Required

## Table of Contents

### Study Session 1: Introduction to Waves

- 1.1 General Idea of Waves
- 1.2 Types and classification of Waves
- 1.3 Wave-forms
- 1.4 Equation of Wave
- 1.5 Principle of Superposition
- 1.6 Generation of Stationary Waves
- 1.7 Properties of Stationary Waves

### Study Session 2: Wave Speed and Transfer of Wave Energy on a String

- 2.1 Speed of Wave
- 2.2 Rate of Energy Transfer by Simple Harmonic Wave on Strings
- 2.3 Sundry Examples

### Study Session 3: Modes of Vibration and Periodic Sound Wave

- 3.1 Modes of Vibration of Stretched String
- 3.2 Resonance
- 3.3 Interference
- 3.4 Periodic Sound Waves
- 3.5 Intensity of Sound Wave
- 3.6 Hearing Limits and Sound Level
- 3.7 Properties of Sound and Musical Note

### Study Session 4: Doppler Effect

- 4.1 Doppler Effect in Sound
- 4.2 Stationary Source and Moving Observer
- 4.3 Stationary Observer and Moving Source
- 4.4 Moving Source and Moving Observer
- 4.5 Effect of Wind
- 4.6 Reflection of Waves

4.7 Source Moving at an Angle to the Observer

Study Session 5: Optics

5.1 Introduction to Optics

5.1 Refraction at Plane Surfaces

5.2 Law of Refraction

5.3 Equation of Refraction

Study Session 6: Applications of Equation of Refraction

6.1 Apparent Depth

6.2 Total Internal Reflection

6.3 Optical Fibre in Communication

6.4 Paths of Rays in the Fibre

Study Session 7: Properties of Images formed by Curved Surfaces

7.1 Convex (diverging) mirror

7.2 Concave (Converging) Mirror

7.3 Concave (Diverging) Lens

7.4 Convex (Converging) Lens.

7.5 Optical Formula

7.6 Sign Conventions in using optical formula

Study Session 8: Thin Lenses

8.1 Description of a thin Lens

8.2 The Lens-Makers' Formula for the Lenses

8.3 Power (P) of a Lens

8.4 Optical Instrument

- 8.5 Lens Aberration
- 8.6 Deviation and Dispersion
- 8.7 Dispersive Power

#### Study Session 9: Introduction to Atomic Models

- 9.1 Atomic Structure
- 9.3 Thomson's Model
- 9.4 Rutherford's Model
- 9.5 Equations of the Rutherford's Model
- 9.6 The Structure of Rutherford's Atomic Model
- 9.7 Limitations of Rutherford's Model
- 9.8 Discovery of Electron

#### Study Session 10: Hydrogen Spectrum and Bohr's Model of Atom

- 10.1 The Hydrogen Spectrum
- 10.2 Quanta
- 10.3 Bohr's Model
- 10.4 Electrons (matter) as Wave
- 10.5 Bohr's Quantum Condition
- 10.6 Bohr's Radii and Energies for Hydrogen Atom
- 10.7 Success and Limitations of Bohr's Model
- 10.8 Electron Cloud Model
- 10.9 Wave-Particle Duality of Light

#### Study Session 11: X-ray and Nuclear Stability

- 11.1 X-Ray Production
- 11.2 Properties of X-rays

### 11.3 Nuclear stability

#### Study Session 12: Radioactivity

##### 12.1 Types of Ionizing Radiation

##### 12.2 Radioactive Decay equation

##### 12.3 Activity

##### 12.4 Half-life

##### 12.5 Mean Life Time

PROPERTIES OF DLCU, IBADAN

**Study Session 1: Introduction to Waves**  
**Expected Duration: 1 week or 3 contact hours**

**Introduction**

In this session, you will learn about the meaning, types, and classifications of waves. You will also be able to express both the travelling and stationary waves in mathematical forms.

**Learning Outcomes**

When you have studied this session, you should be able to explain:

- 1.1 General Idea of Waves
- 1.2 Types and Classification of Waves
- 1.3 Wave-forms
- 1.4 Equation of Wave
- 1.5 Principle of Superposition
- 1.6 Generation of Stationary Waves
- 1.7 Properties of Stationary Waves

**1.1 General Idea of Waves**

A wave is a transfer of energy in a medium in the form of a disturbance that is periodic in space and time without any displacement of the medium. A common example is the disturbance that spread out when a stone is dropped inside a pond. Wave propagation is always characterized by vibrations of certain quantities (scalar or vector). In the case of a wave on a water surface, it is the water molecules (scalar quantity) that vibrate. A careful observation of the particles of the medium in which the wave is propagating will show that these particles (water elements) do not undergo any net motion from their equilibrium positions in the horizontal direction i.e. they do not move along with the wave. They however, oscillate about their equilibrium positions. This pattern of behavior is known as the waveform or wave profile.

## 1.2 Types and classification of Waves

Waves are of two main types: Mechanical and Electromagnetic waves.

Mechanical waves are waves that necessarily require media (solid, liquid, or gas) for their propagation; they cannot propagate in empty space (vacuum). Examples are sound wave, wave on a string, seismic wave etc.

Electromagnetic waves are waves that do not necessarily require material media for their propagation. They can propagate in free space. Examples are radio waves, x-rays, gamma rays, visible light. The vibrating quantities in electromagnetic waves are the electric and magnetic vectors (vector quantities). Waves can also be classified based on the direction of the vibrating quantities. When the direction of vibration (of the vibrating quantities) is perpendicular to the direction of wave propagation, the wave is known as a transverse wave; when the two directions are parallel, the wave is known as a longitudinal wave. All electromagnetic waves are transverse in nature. Sound wave is an example of longitudinal wave.

## 1.3 Wave-forms

The periodic vibration of some quantities in position and time as an evidence of wave propagation is given by a quantity known as wave function. For a transverse wave propagating (travelling) along the positive x-direction in the x-y plane, the wave function is represented mathematically as:

$$y(x, t) = f(x - vt) \quad 1.1$$

The wave function  $y(x, t)$  represents the y – coordinate (i.e. the transverse position) of any particle located at position x at any time t. Where v is the velocity of the wave, and t is time, f gives the shape of the wave.

Suppose the time t is fixed (take a snapshot of the pulse or wave), the wave function  $y(x)$ , also called wave-forms defines a curve representing the geometric shape of the wave at that time.

### Example 1.1

A pulse moving to the right along x axis is represented by the wave function:

$$y(x, t) = \frac{2}{(x - 3.0t)^2 + 1}$$

where x and y are measured in centimeters and t is measured in seconds. Find the expression for the wave function at  $t = 0$  and  $t = 1$



$$y(x, 0) = \frac{2}{x^2 + 1}$$

$$y(x, 1) = \frac{2}{(x-3)^2 + 1}$$

Some waves in nature exhibit a combination of transverse and longitudinal displacements of their vibrating quantities. Example is the travelling wave on the surface of deep water. Each particle of the water moves in nearly circular paths. Waves that travel out from a point under the earth's surface at which an earthquake occurs are combination of transverse and longitudinal. The longitudinal waves are the faster of the two, travelling at speeds in the ranges of 7 to 8 km/s near the surface. They are called P or primary or pressure waves. The slower transverse waves, called S or secondary or shear waves travel through the earth at 4 to 5 km/s near the earth. By recording the time interval between the arrival of these two types of waves using a network of seismograph located at fairly large distance away from the epicenter of the earthquake, the distance from the seismograph to the point of origin of the waves can be determined.

Note that P-waves and S- waves are example of seismic waves. Their speed also depends on the geology of the terrain.

#### 1.4 Equation of Wave

Suppose the quantities that vibrates undergo simple harmonic motion when the disturbance reach them and the disturbance is a transverse wave travelling along the positive x-direction in the x-y planes, the wave function is represents as:

$$y = A \sin(\omega t - \theta) \tag{1.2}$$

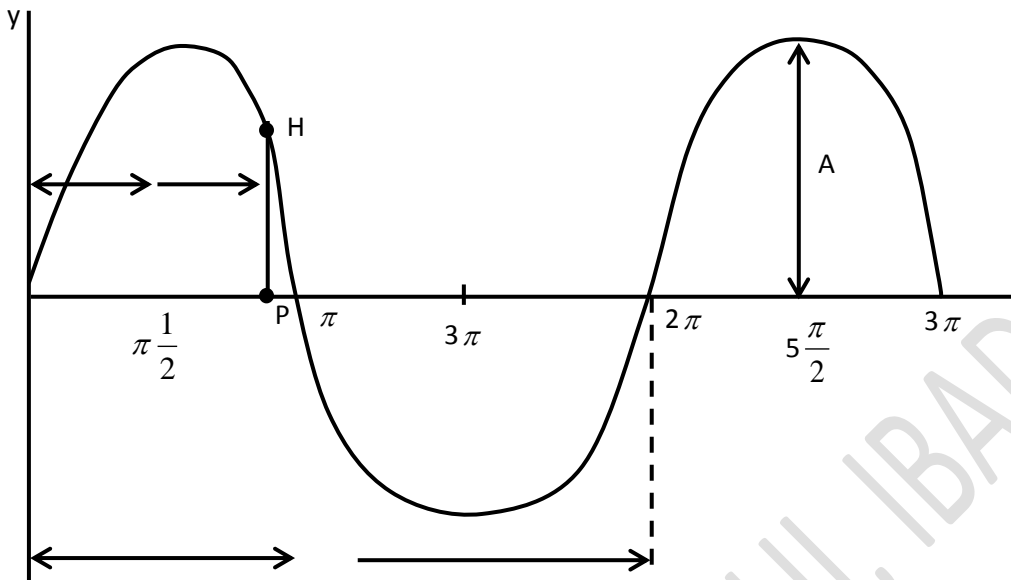

Figure 1.1: waveform

In the figure 1.1 above,  $A$  is amplitude (maximum displacement of the vibrating particle from equilibrium position).

$\lambda$  is the distance between two points (or particles) that are in phase. Two points (particles) are in phase when their directions and displacements from equilibrium positions are identical. A point and its immediate neighbor are out of phase.

Period,  $T$  is the time taken for a whole wave (i.e. one wavelength) to pass through a vibrating particle.

Frequency,  $f$  is the number of complete waves that pass through a vibrating particle in one second.

$$f = \frac{1}{T} \quad 1.3$$

$$v = \frac{\lambda}{T} = \lambda f \quad 1.4$$

$\omega$  is the angular frequency,

$$\omega = \frac{2\pi}{T} = 2\pi f = \frac{2\pi v}{\lambda} \quad 1.5$$

From figure 1.1 above, a point at distance one wavelength ( $1 \lambda$ ) from the origin has a phase difference of  $2 \pi$ . For a particle  $H$ , the phase difference at a distance from the origin is

$$\theta = \frac{x}{\lambda} \times 2\pi \quad 1.6$$

**Note:** Phase difference between two points that are in phase is an integer multiple of  $2 \pi$  while the distance between points in phase is an integer multiple of  $\lambda$

So, the displacement of a particle at a distance from origin is thus given as

$$y = A \sin \left( \frac{2\pi vt}{\lambda} - \frac{2\pi x}{\lambda} \right) \quad 1.7$$

$$y = A \sin \frac{2\pi}{\lambda} (vt - x) \quad 1.8$$

$$y = A \sin 2\pi \left( \frac{t}{T} - \frac{x}{\lambda} \right) \quad 1.9$$

we also define another quantity, wave number,  $k$ . It is similar to  $\omega$ .

$$k = 2 \pi / \lambda \quad 1.10$$

Its unit is rad/metre while that of  $\omega$  is rad/sec.

In terms of this quantities, equation 5 becomes

$$y = A \sin (\omega t - kx) \quad 1.11$$

for waves travelling in the positive x-direction. For waves travelling in the negative x-direction.

$$y = A \sin (kx - \omega t) \quad 1.12$$

Comparing eqn. (1.4) and (1.10), we shall define phase speed as

$$v = f\lambda = \frac{\lambda}{T} = \frac{\omega}{k} \quad 1.13$$

$$v = \frac{\omega}{k}$$

## 1.5 Principle of Superposition

The principle of superposition gives the combine effect at any point in a medium in which two waves are travelling. It states that the resultant displacement at any point is the sum of the separate displacements due to the two waves.

This can be illustrated using two waves (pulses) generated simultaneously at the two ends of stretched string.

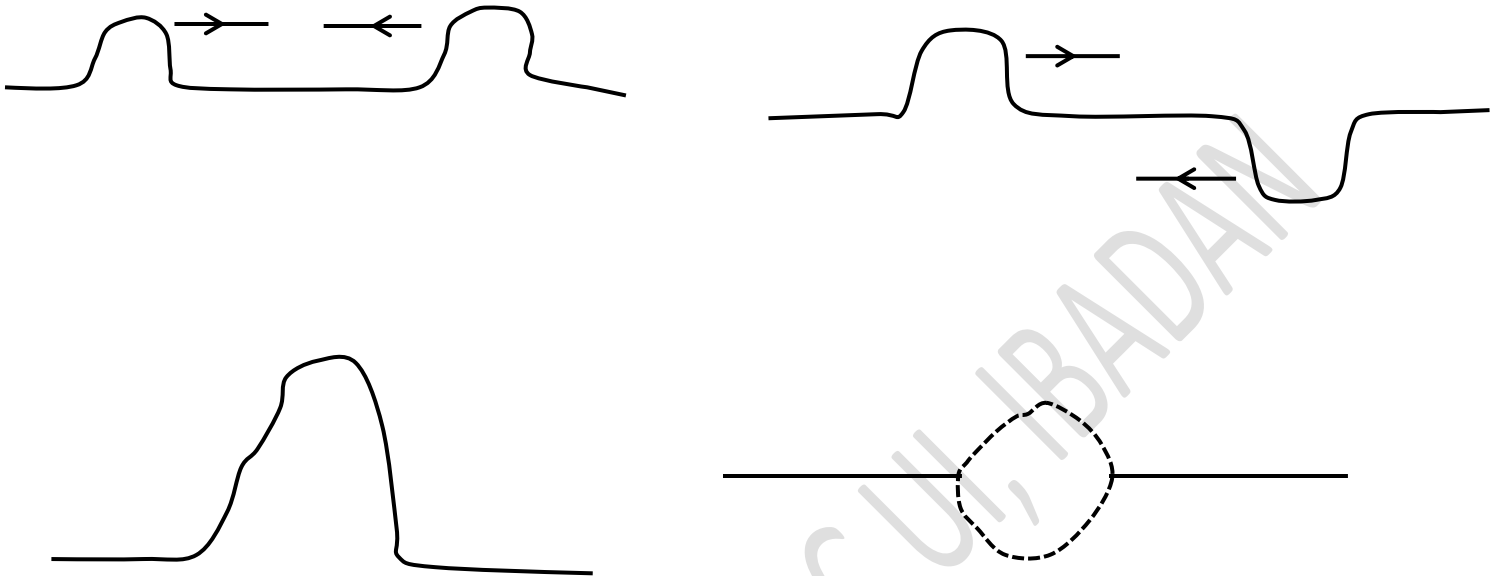
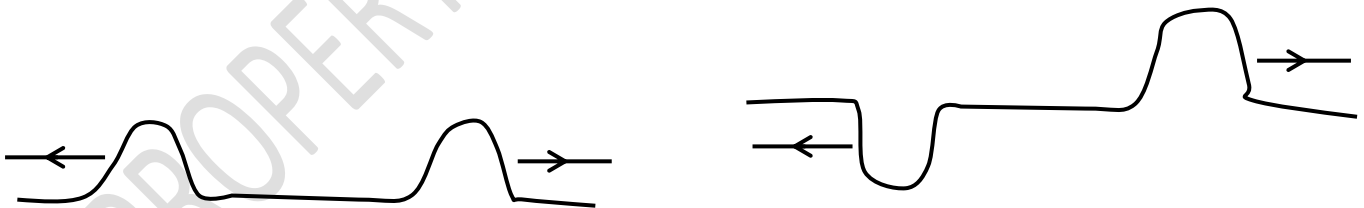
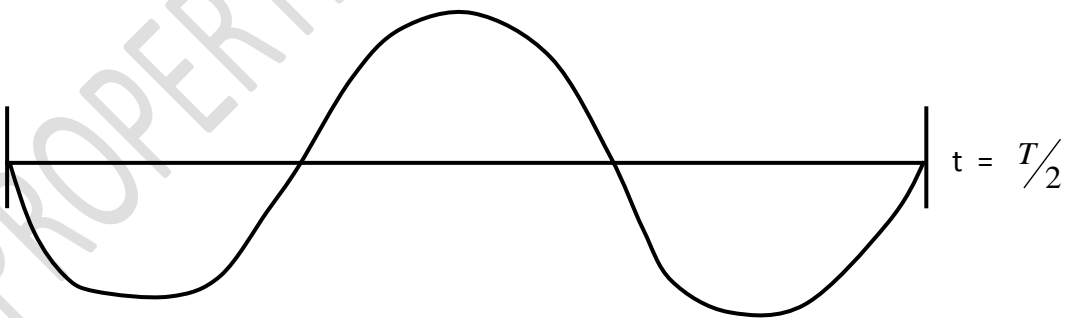
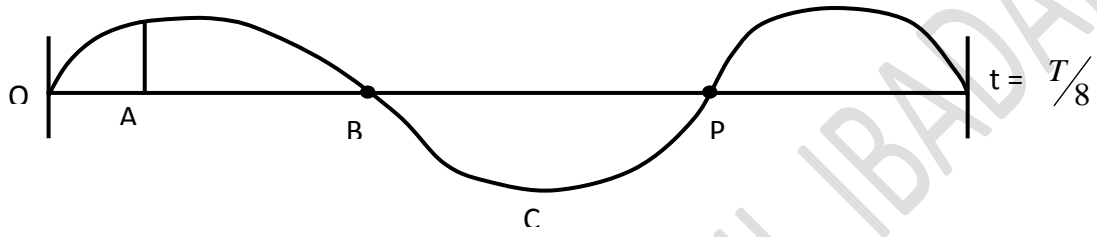
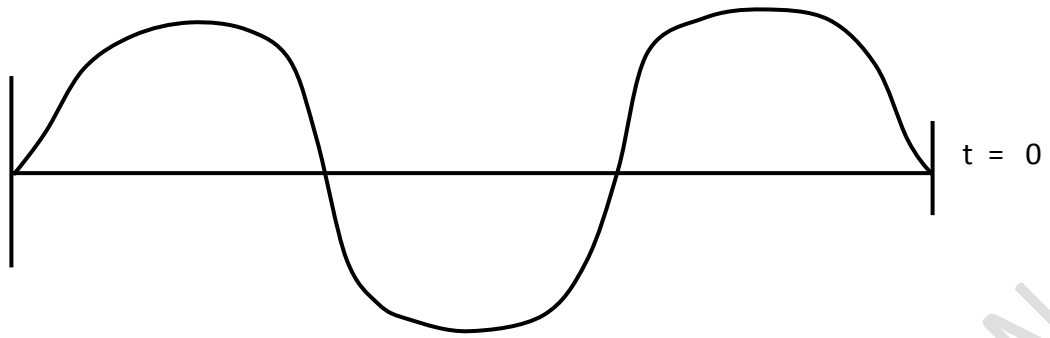

Figure 1.2: superposition of wave pulses

### 1.6 Generation of Stationary Waves

These are extended vibrations that store wave energy in a similar way as capacitor store electrical energy. They are formed when waves of the same amplitude and frequency moving in opposite directions superpose. This wave can set up a stretched string fixed at both ends. Progressive stages (in terms of time) in the motion of the standing wave are shown below.





## 1.7 Properties of Stationary Waves

- (1) There are points (particles) such as B which are permanently at rest (i.e. displacement is permanently zero). These points are called nodes of the stationary wave.
- (2) At points between successive nodes such as A, the vibrations are in phase. This is in contrast to progressive waves in which a point and its neighbor are always out of phase. For stationary wave, when a point is at its maximum displacement, all points are then at their maximum displacement. When a point (other than a node) has zero displacement, all points then have zero displacement.
- (3) Each point along the wave has a different amplitude of vibration from neighboring points. Points such as C which have the greatest amplitude are called antinodes. This again is in contrast with progressive wave in which all points have the same amplitude.
- (4) The wavelength is equal to the distance OP. The wavelength  $\lambda$  is twice the distance between successive nodes or successive antinodes. The distance between successive nodes or antinodes is  $\lambda/2$ . The distance between a node and a neighboring antinode is  $\lambda/4$ . This you need to memorized.

In summary, for progressive waves, phase changes from point to point while amplitude remain constant. For stationary wave, amplitude changes from point to point while phase remains constant. This fact alone can be used to obtain the equation of stationary waves but we choose to use the principle of superposition.

We consider two progressive waves, of the same amplitude and frequency, travelling in opposite directions. Suppose  $y_1 = a \sin(\omega t - kx)$  is a plane progressive wave travelling in positive x-direction while  $y_2 = a \sin(\omega t + kx)$  represents a wave of the same amplitude and frequency travelling in a negative x-direction.

The resultant displacement  $y$  is

$$y = y_1 + y_2 = a[\sin(\omega t - kx) + \sin(\omega t + kx)]$$

After some mathematical transformation

$$y = 2a \sin \omega t \cos kx$$

1.14

where  $2a \cos kx$  is the magnitude of amplitude vibration. The maximum value of the amplitude,  $2a$  occurs when  $\cos kx = 1$  or  $\cos \frac{2\pi x}{\lambda} = 1$

$$\text{i.e. } x = 0, \frac{\lambda}{2}, \lambda, \frac{3\lambda}{2} \quad 1.15$$

These points are antinodes. The amplitude has minimum value of zero when  $\cos kx = 0$

$$kx = \frac{\pi}{2}, \frac{3\pi}{2}, \frac{5\pi}{2} \dots\dots\dots$$

$$x = \frac{\lambda}{4}, \frac{3\lambda}{4}, \frac{5\lambda}{4} \quad 1.16$$

These points are nodes.

Before we considered different modes of vibrations, especially on a stretched string, let us briefly make detour to discuss the speed of wave (i.e. phase speed)

**SUMMARY**

In this unit you have been introduced to the concepts of travelling and stationary waves with the respect to its

- (i) definition, (ii) types, (iii) properties and, (iv) equations

## Study Session 2: Wave Speed and Transfer of Wave Energy on a String

Expected Duration: 1 week or 3 contact hours

### Introduction

In this session, the characteristics of waves in terms of its speed and energy will be described to you and you will also learn how to express them in mathematical forms.

### Learning Outcomes

When you have studied this session, you should be able to explain:

- 2.1 Speed of Wave
- 2.2 Rate of Energy Transfer by Simple Harmonic Wave on Strings
- 2.3 Sundry Examples

#### 2.1 Speed of Wave

A particle of a medium vibrating will set its neighbouring particles vibrating by exerting forces on them through the bonds that connect them. How fast this disturbance is transfer from one particle to another, otherwise known as wave speed depends on two properties of the medium.

**Density:** A dense medium has more mass per unit volume to set in motion and so responds sluggishly to a disturbance. In this case the vibrating particle has large number of neighbouring particle to give its force and therefore produce smaller acceleration.

**Stiffness:** If the bonds between particles are stiff then a small disturbance of one particle will result in a larger force on neighbouring particles, giving them greater acceleration and the disturbance is transfer rapidly.

Wave speed will be slow in a dense, weakly bonded medium and fast in a low-density, stiffly bonded one. Through dimensional analysis.

$$\text{Speed of mechanical wave} \propto \sqrt{\frac{\text{stiffness factor}}{\text{density factor}}}$$

The speed of different types of waves are given below:

Transverse wave on a string

$$v = \sqrt{\frac{T}{\mu}}$$

2.1



Longitudinal waves on a string

$$v = \sqrt{\frac{kl}{\mu}} \quad 2.2$$

Longitudinal waves (e.g. sound in a rod)

$$v = \sqrt{\frac{E}{\rho}} \quad 2.3$$

Longitudinal waves (e.g. sound in liquid)

$$v = \sqrt{\frac{B}{\rho}} \quad 2.4$$

Sound waves in a gas (e.g sound made by bat)

$$v = \sqrt{\frac{\gamma P}{\rho}} = \sqrt{\frac{\gamma RT}{M}} \quad 2.5$$

Ripples

$$v = \sqrt{\frac{2\pi\sigma}{\rho\lambda}} \quad 2.6$$

Surface waves in shallow water

$$v = \sqrt{gh} \quad 2.7$$

Surface waves in deep water

$$v = \sqrt{\frac{g\lambda}{2\pi}} \quad 2.8$$

Electromagnetic waves

$$c = \frac{1}{\sqrt{\epsilon_0\mu_0}} \quad 2.9$$

Where T is tension,  $\mu$  is mass per unit length, E is young modulus,  $\rho$  is density, B is bulk modulus, l is length of string, k is spring constant,  $\gamma$  is a dimensionless constant (=1.4 in air), P is pressure, R is gas constant, M is molar mass,  $\sigma$  is surface tension,  $\lambda$  is wavelength, g is gravitational field strength, h is depth,  $\epsilon_0$  and  $\mu_0$  is the permittivity and permeability of free space respectively.

## 2.2 Rate of Energy Transfer by Simple Harmonic Wave on Strings

Consider a sinusoidal wave travelling on a string. Suppose the source of the energy being transported by the wave is some external agent at the left end of the string. It sends pulses through the string by causing it to move up and down. We shall focus our attention on a segment of the string of length  $\Delta x$  and mass  $\Delta m$ . Each such segment moves with the same angular frequency  $\omega$  and amplitude,  $A$  vertically in simple harmonic motion (SHM).

For a particle undergoing SHM, the potential energy is

$$U = \frac{1}{2}ky^2 \quad 2.10$$

where  $y$  represents particle's displacement and  $\omega^2 = \frac{k}{m}$

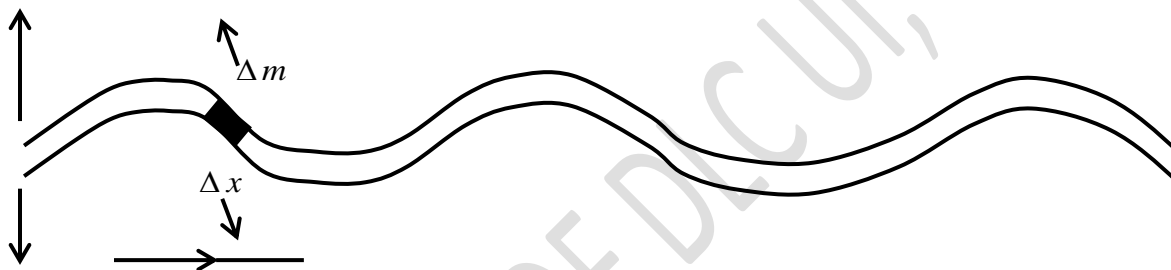

Figure 1.3: transfer of energy along a string

$$\text{Hence, } U = \frac{1}{2}m\omega^2y^2 \quad 2.11$$

If this eqn. is only applied to the segment of mass  $\Delta m$ , Potential Energy for the segment,

$$\Delta U = \frac{1}{2}(\Delta m)\omega^2y^2.$$

But mass per unit length for the string is  $\mu = \frac{\Delta m}{\Delta x}$

$$\text{So } \Delta U = \frac{1}{2}(\mu\Delta x)\omega^2y^2$$

As the length of the segment shrinks to zero,  $\Delta x \rightarrow dx$

$$\therefore dU = \frac{1}{2}(\mu dx)\omega^2y^2$$

If we replace displacement  $y$  by the wave function  $y = A\sin(kx - \omega t)$

$$dU = \frac{1}{2} \mu \omega^2 [A \sin(kx - \omega t)]^2 dx$$

$$= \frac{1}{2} \mu \omega^2 A^2 \sin^2(kx - \omega t) dx$$

At time  $t = 0$ ,

$$dU = \frac{1}{2} \mu \omega^2 A^2 \sin^2 kx dx$$

The total potential energy in one wavelength

$$U_\lambda = \int du = \int_0^\lambda \frac{1}{2} \mu \omega^2 A^2 \sin^2 kx dx$$

$$= \frac{1}{2} \mu \omega^2 A^2 \int_0^\lambda \sin^2 kx dx$$

$$= \frac{1}{2} \mu \omega^2 A^2 \left[ \frac{1}{2} x - \frac{1}{4k} \sin 2kx \right]_0^\lambda$$

$$= \frac{1}{2} \mu \omega^2 A^2 \left( \frac{1}{2} \lambda \right)$$

$$= \frac{1}{4} \mu \omega^2 A^2 \lambda \tag{2.12}$$

Since each segment of the string also has kinetic energy due to its motion, the total kinetic energy in one wavelength is given as

$$K_\lambda = \int dk = \frac{1}{4} \mu \omega^2 A^2 \lambda \tag{2.13}$$

The total energy in one wavelength of the wave

$$E_\lambda = U_\lambda + K_\lambda = \frac{1}{2} \mu \omega^2 A^2 \lambda \tag{2.14}$$

As the wave moves along the string, this amount of energy passes by a given point on the string during one period of the oscillation.

Thus, the power, or the rate of energy transfer associated with the wave.

$$P = \frac{E_\lambda}{\Delta t} = \frac{\frac{1}{2} \mu \omega^2 A^2 \lambda}{T} = \frac{1}{2} \mu \omega^2 A^2 \frac{\lambda}{T}$$

$$= \frac{1}{2} \mu \omega^2 A^2 \lambda f$$

$$= \frac{1}{2} \mu \omega^2 A^2 V$$

2.15

**The rate of energy transfer in any sinusoidal wave is proportional to the square of the angular frequency,  $\omega$  and the square of the amplitude,  $A$ .**

### 2.3 Sundry Examples

#### Example 2.1:

The equation of a transverse wave on a rope of weight 0.25N, length 130cm is given by

$$y(x, t) = 10 \sin \pi (0.01x + 2.00t)$$

where  $y$  and  $x$  are in cm and  $t$  is in seconds. Find the (i) amplitude (ii) frequency (iii) wavelength (iv) velocity of the wave (v) the maximum transverse speed of a particle in the rope and (vi) the maximum kinetic energy per unit length of the string (take  $g = 10\text{m/s}^2$ ).

#### Solution

Compare  $y(x, t) = 10 \sin \pi (0.01x + 2.00t)$

with

$$y(x, t) = A \sin (\omega t + kx).$$

$$y(x, t) = 10 \sin (0.01 \pi x + 2.00 \pi t)$$

(i)  $A = 10\text{cm}$

(ii)  $\omega = 2\pi f = 2\pi$

$$f = 1\text{Hz}.$$

$$\lambda = 200\text{cm}.$$

(iii)  $v = \lambda f$

$$v = 1 \times 200 = 200\text{cm/s}.$$

(iv) Speed,  $V$ ; of vibrating particles in the rope is

$$V = \left| \frac{dy}{dt} \right| = 20\pi \cos (0.01 \pi x + 2\pi t)$$

$$V_{\max} \text{ when } \cos (0.01 \pi x + 2\pi t) = 1$$

Hence,  $V_{\max} = 20\pi = 62.8\text{cm/s}.$

(v) Maximum kinetic energy per unit length

$$= \frac{1}{2} \mu V_{\max}^2$$

$$\text{But } \mu = \frac{M}{L} = \frac{0.25/10}{1.3} = 0.019 \text{ kg/m}$$

$$= \frac{1}{2} \times 0.019 \times (0.0628)^2$$

$$= 0.0037 \text{ J/m}$$

A stretched string for which  $\mu = 5.00 \times 10^{-2} \text{ kg/m}$  is under a tension of 80.0N. How much power must be supplied to the string to generate sinusoidal waves at a frequency of 60Hz and an amplitude of 6.00 cm.

$$V = \sqrt{\frac{T}{\mu}} = \sqrt{\frac{80}{5.00 \times 60^{-2}}} = 40.0 \text{ m/s}$$

$$\text{But } P = \frac{1}{2} \mu \omega^2 A^2 V$$

$$\text{where } \omega = 2\pi f = 2\pi \times 60 = 377 \text{ s}^{-1}$$

$$\therefore P = \frac{1}{2} \times 5.00 \times 10^{-2} \times 377^2 \times 6.00 \times 10^{-4} \times 40 = 512 \text{ J/s}$$

### Example 2.2:

A type of fish called dolphins uses sound wave to locate food. How much time passes between the moment the fish emits a sound pulse and the moment it receives its reflection and thereby detects a distance target 110 m away [ $B = 2.1 \times 10^9 \text{ N/m}^2$ ;  $\rho = 1.00 \times 10^3 \text{ kg/m}^3$ ]

Total distance covered by the sound wave = 2 x 110m.

$$t = \frac{x}{v} = \frac{220}{v}$$

$$v = \sqrt{\frac{B}{\rho}} = \sqrt{\frac{2.1 \times 10^9}{1 \times 10^3}} = 1.4 \text{ km/s}$$

$$t = \frac{220}{1400} = 0.016 \text{ s}$$

**Example 2.3:**

- 1(a) A uniform string of length 200cm and mass 6g is kept under a tension of 70 N in the horizontal direction. How long will take a transverse pulse to cross the whole length of the string?
- (b) If the string is replaced by another one of the same material but of double thickness and of length 70 cm, how should the tension be adjusted so that the wave will cross the entire length within the same time interval as in (a)
- (a) Velocity of transverse wave

$$v = \sqrt{\frac{T}{\mu}}$$

$$\text{where } T = 70, \mu = \frac{0.006}{2} \text{ kg/m} = 0.003 \text{ kg/m}$$

$$v = \sqrt{\frac{70}{0.003}} = 153 \text{ m/s}$$

Time to cross the string

$$t = \frac{\text{length}}{\text{velocity}} = \frac{2.00}{153} = 0.013 \text{ s}$$

- (b) Since the thickness is now doubled, the  $\mu$  has also doubled

$$\begin{aligned} \mu' &= 2 \times 0.003 \text{ kg/m} \\ &= 0.006 \text{ kg/m} \end{aligned}$$

$$v = \sqrt{\frac{T'}{\mu'}} = \sqrt{\frac{T'}{0.006}}$$

since time of cross is still 0.013s

$$v = \frac{0.7}{0.013} = 53.85 \text{ m/s}$$

So, the tension required,  $T'$

$$53.85 = \sqrt{\frac{T'}{0.006}}$$

$$T' = (53.85)^2 \times 0.006$$

$$17.40 \text{ N}$$

The tension in the string reduced to 17.40N

## SUMMARY

In this unit, you have been introduced to formulas for characterizing waves with respect to (i) wave speed in different media and (ii) energy on a vibrating string

### Self Assessment Question

1. One end of a uniform rope of length  $L$  is tied to the ceiling while a mass  $M$  is suspended from the other force end. A transverse wave is set up at the lower end. Show that the velocity of the wave increases up along the rope. Give the expression for the time taken for the wave to reach the fixed end.

## Study Session 3: Modes of Vibration and Periodic Sound Wave

**Expected Duration: 1 week or 3 contact hours**

### Introduction

In this session, you will learn how to express standing waves in different modes of vibration; resonance and interference will be introduced; and periodic sound waves and its properties will also be explained

### Learning Outcomes

When you have studied this session, you should be able to explain:

- 3.1 Modes of Vibration of Stretched String
- 3.2 Resonance
- 3.3 Interference
- 3.4 Periodic Sound Waves
- 3.5 Intensity of Sound Wave
- 3.6 Hearing Limits and Sound Level
- 3.7 Properties of Sound and Musical Note

### 3.1 Modes of Vibration of Stretched String

If a wire is stretched between two points  $P$ ,  $P$  and is plucked in the middle, a transverse wave travels along the wire and is reflected at the fixed end. A stationary wave is set up in the

wire. The possible modes of vibrations corresponding to fundamental frequency and the overtones are obtained as follows:

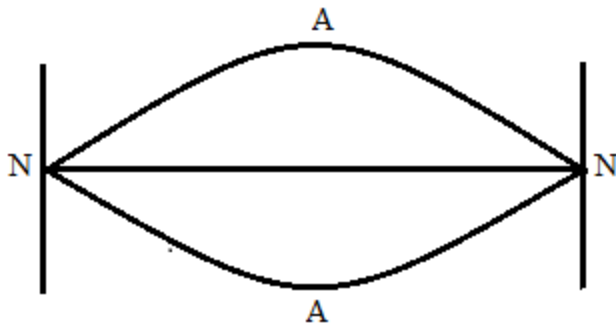

Figure 3.1: first harmonic

Hence

$$\lambda = \frac{\lambda}{2}$$

So  $\lambda = 2l$

The frequency of vibration  $f = \frac{v}{\lambda}$

$$f_o = \frac{v}{2l} \quad 3.1$$

But  $v = \sqrt{\frac{T}{\mu}}$

So  $f_o = \frac{1}{2l} \sqrt{\frac{T}{\mu}} \quad 3.2$

Other possible modes of vibration corresponding to the overtones are derived as follows:

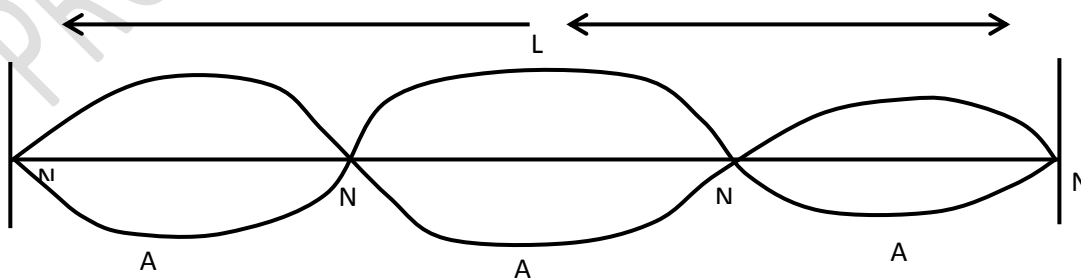



Figure 3.2: Generation of first overtone on a stretched string fixed at both ends

$$\lambda = \frac{3\lambda}{2}$$

$$\lambda = \frac{2l}{3}$$

$$f_1 = \frac{v}{\lambda} = \frac{v}{\frac{2l}{3}}$$

$$f_1 = \frac{3v}{2l} \tag{3.3}$$

So  $f_1 = 3f_o$  3.4

The possible overtones are odd multiple of fundamental frequency when the string is plucked in the middle. That is,

$$f_o, 3f_o, 5f_o, 7f_o \dots \tag{3.5}$$

Frequency of normal modes that exhibits an integer relationship (even or odd multiple of fundamental frequency) are called harmonic series. Oscillating systems such as drum exhibits normal modes of vibrations (i.e. they have overtones) but the frequencies are not related as integer multiple of a fundamental frequency.

### 3.2 Resonance

Resonance is a phenomenon that occurs when an external impulse or disturbance causes a medium to vibrate at one of its natural frequencies. Resonance frequency is the frequency of vibration of a medium which is equal to the frequency of the external impulse or disturbance. When a column of gas is set into series of oscillations it can emit a sound note at a certain frequency depending on how the oscillations take place.

#### Example

The fundamental frequency of a pipe, which is closed at both ends and contains hydrogen, is half of the one containing air which is opened at one end and closed at the other. If the open pipe is 25cm long and the gases are both at normal temperature and pressure (NTP), calculate the length of the closed pipe and the two fundamental frequencies (take the velocity of sound in air at NTP as 330m/s and in hydrogen as 1300m/s).

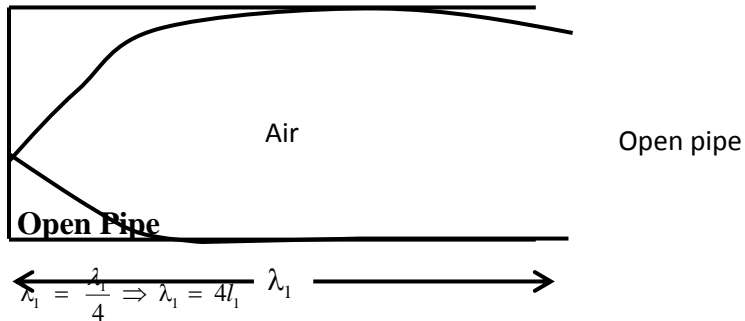
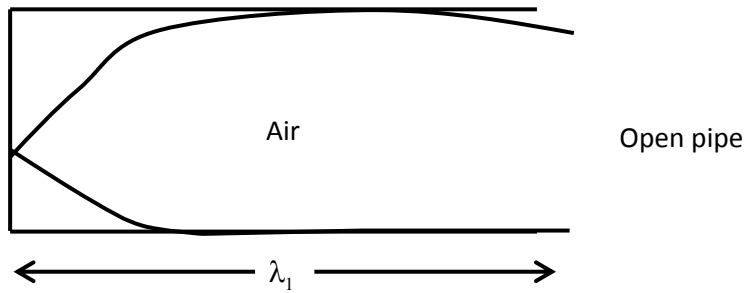

### Chosen Pipe

$$\lambda_2 = \frac{\lambda_2}{2} \Rightarrow \lambda_2 = 2L_2$$

$$f_{open} = \frac{v_{air}}{\lambda_1} = \frac{v_{air}}{4L_1}$$

$$f_{closed} = \frac{v_H}{\lambda_2} = \frac{v_H}{2L_2}$$

$$f_{closed} = \frac{1}{2} f_{open}$$

But  $f_{open} = 2f_{closed}$

$$f_{open} = \frac{v_{air}}{4L_1} = \frac{v_H}{L_2}$$

$$v_{air} = 330, v_H = 1300 \text{ and } L_1 = \frac{25}{100}$$

$$\text{So, } \frac{330}{4 \times 0.25} = \frac{1300}{L_2}$$

$$L_2 = 3.94 \text{ m}$$

### 3.3 Interference

When two or more waves of the same frequency overlap, the phenomenon of interference occurs. From the principle of superposition, two crests arriving together at a place produce constructive interference while a crest and a trough produce a destructive interference. Waves can be said to be coherent or incoherent. Waves are coherent when their sources are coherent. Such waves will have the same wavelength or frequency and at the same time be in phase.

When two coherent waves that have taken different paths meet and interfere constructively at a point, their path difference is zero or integral multiple of their wavelength i.e.

$$\text{Path difference} = n\lambda$$

If they interfere destructively, their path difference is an odd multiple of half wavelength (i.e.  $(2m+1)\lambda/2$ ) These are proves that the two waves were in phase at their source.

Example

Two small loudspeakers A, B, 1.00 m apart are connected to the same oscillator so that both emit sound waves of frequency 1700Hz in phase. A sensitive detector, moving parallel to the line AB along PQ 2.40m away, detects a maximum wave at P on the perpendicular bisector MP of AB and another maximum wave when it first reaches a point Q directly opposite B. Calculate the speed of the sound waves in air from these measurements.

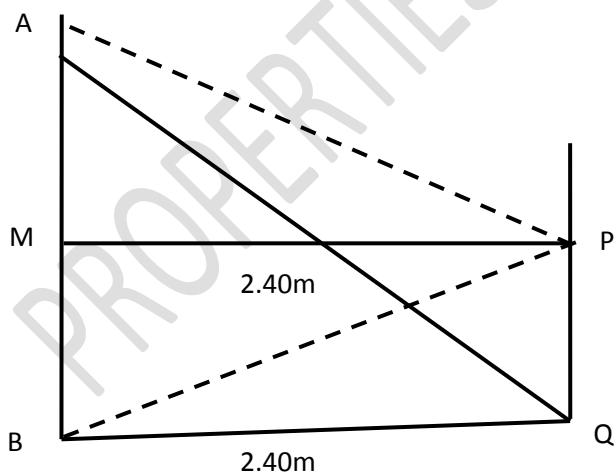

There are constructive interferences at P and Q.

Since  $AP = BP$ ,  $AP - BP = 0$ ,

Since Q is the first maximum after P.

$$AQ - BQ = \lambda$$

$$\sqrt{1^2 + 2.40^2} - 2.40 = \lambda$$

$$2.60 - 2.40 = \lambda$$

$$\sqrt{s} \lambda f = 0.2 \times 1700$$

$$= 340 \text{ m/s.}$$

### 3.4 Periodic Sound Waves

As sound travel through the air, the particles of the air vibrate to produce changes in density and pressure along the direction of motion of the wave. If the source of the sound waves vibrates sinusoidally, the pressure variations are also sinusoidal. The mathematical representation of the sinusoidal sound wave is very similar to that of sinusoidal waves on strings.

$$\Delta P = \Delta P_{\max} (kx - \omega t) \quad 3.6$$

$\Delta P$  is the variation in pressure.

$\Delta P_{\max}$  is the maximum change in pressure from normal atmospheric pressure).

$$\Delta P_{\max} = \rho v \omega S_{\max} \quad 3.7$$

Where  $v$  is the velocity of the wave in the medium,  $\rho$  is the density of the medium,  $\omega$  is the angular frequency and  $S_{\max}$  is the maximum position of the particles of the medium relative to equilibrium position.

### 3.5 Intensity of Sound Wave

This is defined as the rate at which the energy transported by the wave transfers through a unit area. A perpendicular to the direction of the wave propagation.

$$I = \frac{P}{A} \quad 3.8$$

In terms of pressure amplitude,

$$I = \frac{\Delta P_{ma}^2}{2\rho v} \quad 3.9$$

Consider a point source that emits sound waves uniformly in all directions. These types of waves are referred to as spherical waves.

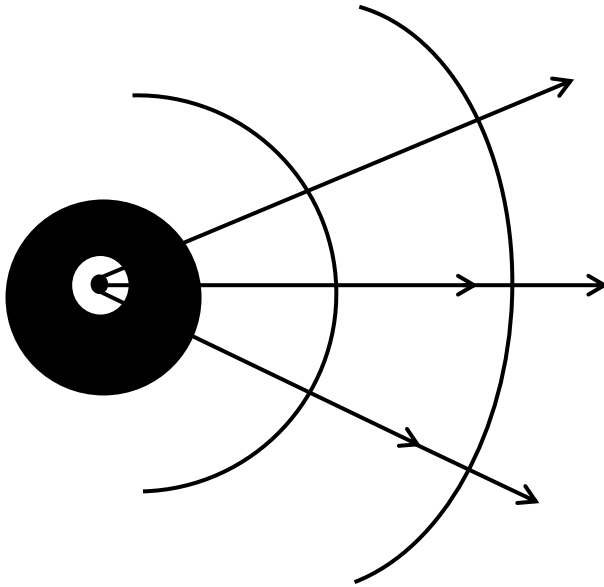

Figure 3.3: sound waves propagating from a source

Each arc represents a wave front (i.e. a surface where all the particles are vibrating in phase).

The wave intensity at a distance  $r$  from the source is

$$I = \frac{P_{ave}}{A} = \frac{P_{ave}}{4\pi r^2} \quad 3.10$$

This is an inverse-square law.

$P_{ave}$  is the average power emitted by the source.

### 3.6 Hearing Limits and Sound Level

Sound waves are divided into three categories that cover different frequency ranges.

- (1) Audible waves lie within the range of sensitivity of human ear (1 KH – 20 KHz).
- (2) Infrasonic waves – they have frequencies below audible range. Elephants communicate with one another over many kilometers of distance by using infrasonic waves.

- (3) Ultrasonic waves have frequencies above the audible range. Dogs can detect ultrasonic waves. You may be able to call your dog silently if you can emit sound with this range. It is also used in medical imaging.

Human ear can detect wide range of intensities of sound. The intensity of the faintest sounds (at a frequency of 1000Hz) is  $1.00 \times 10^{-12} \text{ W/m}^2$ . This sound is said to be at threshold of hearing.

The intensity of sound corresponding to the threshold of pain (at a frequency of 1000Hz) is  $1 \text{ W/m}^2$ .

. For ease of calculation a logarithmic scale is used to express sound level,  $\beta$

$$\beta \equiv 10 \log \left( \frac{I}{I_0} \right) \quad (\text{decibels } dB) \quad 3.11$$

$I_0$  is the reference intensity usually taken to be threshold of hearing.

$$I_0 = 1 \times 10^{-12} \text{ W/m}^2$$

$I$  is the intensity to which  $\beta$  corresponds.

What sound level corresponds to threshold of pain?

$$\begin{aligned} P &= 10 \log \left( \frac{1}{10^{-12}} \right) \\ &= 10 \log 10^{12} \\ &= 120 \text{ dB} \end{aligned}$$

### Example 3.1

Determine the pressure amplitude and displacement amplitude associated with faintest sound human ear can detect.

$$\begin{aligned} \Delta P_{\max} &= \sqrt{2\rho v I} \\ &= \sqrt{2(1.20) \times 343 \times 1 \times 10^{-12} \text{ W/m}^2} \\ &= 2.87 \times 10^{-5} \text{ N/m}^2 \\ &= 2.87 \times 10^{-5} \text{ N/m}^2 \end{aligned}$$

$$S_{\max} = \frac{\Delta P_{\max}}{\rho v \omega} = \frac{2.87 \times 10^{-5}}{1.2 \times 343 \times 2\pi \times 1000}$$

$$= 1.11 \times 10^{-11} M$$

### Example 3.2

A point source emits sound waves with an average power output of 100W. What is the intensity in 5.00 m from the source?

$$I = \frac{P_{ave}}{4\pi r^2} = \frac{100}{4\pi \times 5^2} = \frac{1}{\pi} W/m^2$$

### 3.7 Properties of Sound and Musical Note

A musical note is played on a string instruments (guitar, cello or piano) by distorting the string into a shape that corresponds to the desire harmonic. However, since this maneuver is always difficult to perform; other harmonics which are integer multiple of the desired harmonic are also excited. The predominant sound will correspond to the desire harmonic (it has the highest amplitude). Other harmonic will be heard in the background of the first or desired harmonic.

The frequency of the musical note (i.e. the first harmonic or fundamental frequency) can be varied for string instruments by varying either the tension or its length. For guitar or violin, the tension is adjusted by a screw or by tuning pegs located on the neck of the instrument. The fundamental frequency,  $f_o$  increases as Tension, T increases.

Once, the instrument is tuned, the frequency can be changed by moving the hand along the neck thereby changing the oscillating part of the string.  $f_o$  increases as length, L decreases.

$$f_o = \frac{1}{2l} \sqrt{\frac{T}{\mu}}$$

**Pitch** is a psychological reaction to a sound that allows the listener to place the sound on a scale of low or high frequency (bass to treble) whereas, **Loudness** is a psychological respond to a sound. It depends on both intensity and the frequency of sound. **As a rule:** A doubling in loudness is approximately equal to an increase in sound level by 10 dB.

**Quality or Timbre:** This is human perceptive response associated with various mixtures of harmonious that allow us to distinguish two instruments that are playing the same note.

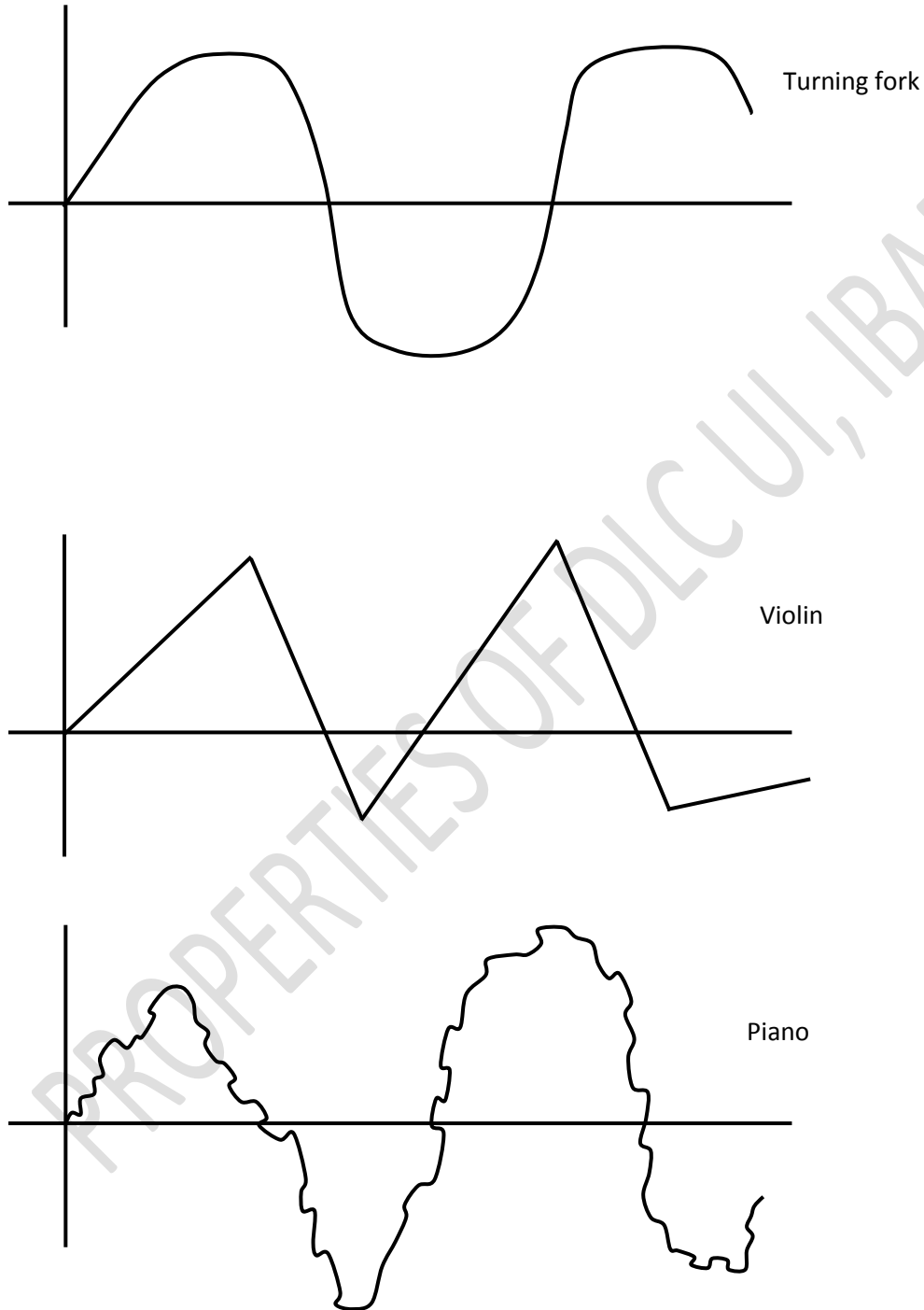

Figure 3.4: sketch of pattern of harmonics observed for tuning fork, violin and piano



The fundamental frequency (first harmonic) in the three instruments above is  $f_o$ . But violin could have harmonic that are  $f_o, 2f_o, 3f_o$  while piano has  $f_o, 2f_o, 4f_o, 6f_o$ . The quality of the sound produced by the two instruments will be different.

### Exercise 3.1

What happen when the string is plucked at a point  $\frac{1}{4}$  of the whole length? Derive the harmonics

### SUMMARY

In this unit you have been introduced to the concepts of modes of vibration, sound wave and properties with the respect to its

- (i) harmonics, (ii) overtones, (iii) resonance (iv) interference (v) hearing limits (vi) pitch (vii) loudness

### Self Assessment Question

Distinguish between : (i) harmonics and overtone (ii) resonance and interference and, (iii) loudness and pitch

## Study Session 4: Doppler Effect

**Expected Duration: 1 week or 3 contact hours**

### Introduction

In this session, you will be introduced to Doppler effect and how to set it up using different configurations of the source of sound and receiver

### Learning Outcomes

When you have studied this session, you should be able to explain:

- 4.1 Doppler Effect in Sound
- 4.2 Stationary Source and Moving Observer
- 4.3 Stationary Observer and Moving Source
- 4.4 Moving Source and Moving Observer
- 4.5 Effect of Wind
- 4.6 Reflection of Waves
- 4.7 Source Moving at an Angle to the Observer

#### 4.1 Doppler Effect in Sound

When there is a relative motion between the source of a wave and an observer of the wave, the observer receives an apparent frequency that differs from the original frequency. This phenomenon is known as the Doppler Effect.

#### 4.2 Stationary Source and Moving Observer

We consider the case of sound wave in which an observer O is moving and the source S of the sound is stationary. For simplicity, we assume that the air is also stationary and the observer moves directly toward the source. The observer moves with a speed towards a stationary point source ( $v_s = 0$ ).

Suppose the frequency and wavelength of the source are  $f$  and  $\lambda$  respectively and the velocity of sound wave is  $v$ . If the observer is stationary,  $f$  wave fronts will be detected per second (i.e.

$v_o = v_s = 0$  The observed frequency = source frequency.

When the observer moves toward the source, the speed of the waves relative to the observer is

$v' = v + v_o$  but  $\lambda$  is unchanged. The frequency heard by the observer is

$$f' = \frac{v'}{\lambda} = \frac{v + v_o}{\lambda}$$

But  $\lambda = \frac{v}{f}$

$$f' = \left( \frac{v + v_o}{\frac{v}{f}} \right) = \left( \frac{v + v_o}{v} \right) f$$

$$f' = \left( 1 + \frac{v_o}{v} \right) f$$

(This is the case of observer moving toward the source).

If the observer is moving away from the source, the speed of the wave relative to the observer is

$$v' = v - v_o .$$

The frequency heard by the observer is

$$f' = \left( 1 - \frac{v_o}{v} \right) f$$

(This is the case of observer moving away from the source).

So, in general when the observer moves with speed  $v$  relative to a stationary source, the frequency heard by the observer is

$$f' = \left(1 \pm \frac{v_o}{v}\right) f \quad 4.1$$

### 4.3 Stationary Observer and Moving Source

If the source  $S$  of a wave is stationary, the  $f$  wave fronts sent out in one second towards the observer  $O$  would occupy a distance  $v$  and  $\lambda = v/f$

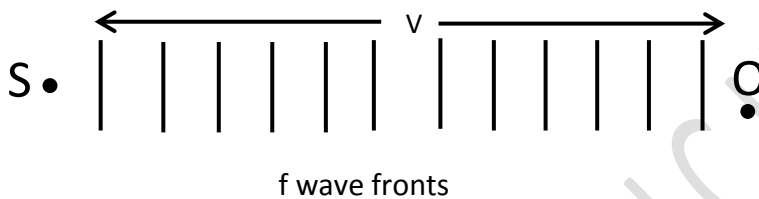

If the  $S$  moves with a speed  $v_s$  towards  $O$ , the  $f$  wave fronts sent out occupy a smaller distance  $v - v_s$ . Since  $S$  has moved a distance  $v_s$  per second towards  $O$ .

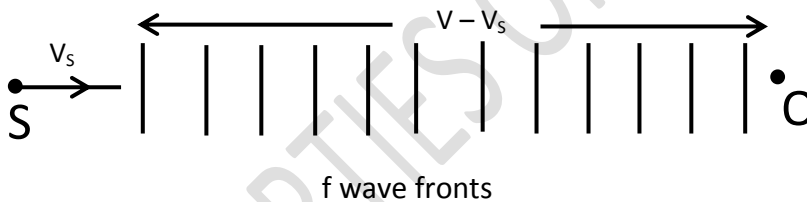

The wavelength  $\lambda'$  of the waves reaching  $O$  is now  $\frac{(v - v_s)}{f}$ .

The frequency heard by the observer is

$$f' = \frac{v}{\lambda'} = \frac{v}{\frac{v - v_s}{f}}$$

$$f' = \left(\frac{v}{v - v_s}\right) f \quad 4.2$$

For source moving away from the observer

$$f' = \left( \frac{v}{v + v_s} \right) f$$

So, in general when the source S moves with velocity  $v_s$  relative to the observer.

$$f' = \left( \frac{v}{v + v_s} \right) f \quad 4.3$$

#### 4.4 Moving Source and Moving Observer

By combining equation (1) and (2), the observed frequency is obtained as

$$f' = \left( \frac{v \pm v_o}{v \mp v_s} \right) f \quad 4.4$$

The upper signs (*i.e.*  $+v_o$  and  $-v_s$ ) refer to motion of one toward the other, and the lower equations (*i.e.*  $-v_o$  and  $+v_s$ ) refer to motion of one away from the other.

#### 4.5 Effect of Wind

To simplify the discussion, we have treated the medium in which the sound is propagating (air) as being stationary. Suppose there is a wind of velocity  $v_w$  in the direction of the line SO joining the source S to the observer O. Since the air has a velocity  $v_w$  relative to the ground, and the velocity of sound relative to the air is  $v$ , the velocity of the waves relative to the ground is  $v + v_w$  if the wind is blowing in the same direction as SO. So, we replace  $v$  in our previous expression for  $f'$  by  $v + v_w$ . If the wind is blowing in opposite direction to SO, the velocity  $v$  is replaced by  $v - v_w$ .

##### Example 4.1

A car, sounding a horn producing a note of 500Hz, approaches and then passes a stationary observer, O at a steady speed of  $20\text{ms}^{-1}$ . Calculate the change in pitch of the note heard by O (velocity of sound =  $340\text{m/s}$ ).

$$f' = \left( \frac{v \pm v_o}{v \mp v_s} \right) f$$

$v_o = 0$  (Stationary observer)

$$f' = \left( \frac{v}{v \pm v_s} \right) f$$

Source S approaching the observer O: use upper sign in the denominator

That is,

$$f' = \left( \frac{v}{v - v_s} \right) f$$

Substituting the numerical values,

$$\begin{aligned} f' &= \left( \frac{340}{340 - 20} \right) 500 \\ &= 531 \text{ Hz} \end{aligned}$$

Source S moving away from observer O: use the lower sign in the denominator

$$f'' = \left( \frac{v}{v + v_s} \right) f$$

$$f'' = \left( \frac{340}{340 + 20} \right) 500$$

$$f'' = 472 \text{ Hz}$$

$$\text{Change in pitch} = \frac{f''}{f'} = \frac{472}{531} = 0.9$$

#### 4.6 Reflection of Waves

Consider a source of sound A approaching a fixed reflector R such as a wall or bridge, for example. The reflected waves then appear to travel from R to A as if they came from the mirror image A' of A in R.

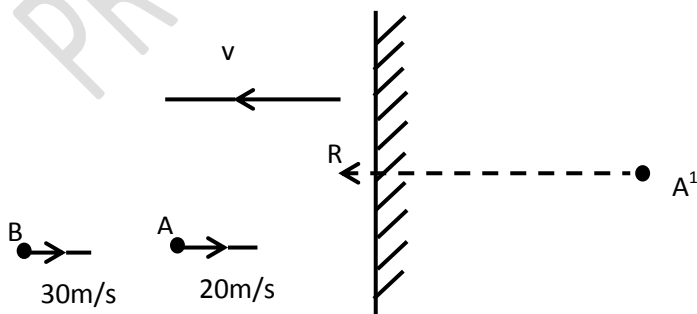

Suppose a car A approaches R with a velocity of 20m/s when sounding a note of 1000Hz from its horn, and that another car B behind A is travelling towards A with a velocity of 30m/s. Calculate the apparent frequency of the note heard from R and that of the note heard from A by the driver in B.

$$f' = \left( \frac{v \pm v_o}{v \mp v_s} \right) f$$

$$f' = \left( \frac{v + v_o}{v - v_s} \right) f$$

As observer B is approaching R  
A' is also approaching B).

$$f'_R = \left( \frac{v + v_o}{v - v_s} \right) f$$

Substituting the numerical values

$$= \left( \frac{340 + 30}{340 - 20} \right) \times 1000$$

$$= 1156\text{Hz}$$

To find  $f'_A$

As B is approaching A, A is moving away from B.

$$f'_A = \left( \frac{v + v_o}{v + v_s} \right) f$$

$$= \left( \frac{340 + 30}{340 + 20} \right) \times 1000$$

$$= 1028\text{Hz}$$

#### Exercise 4.1

1. A boy sitting on a swing which is moving to an angle of  $30^\circ$  from the vertical is blowing a whistle which has a frequency of 1.0 KHz. The whistle is 2.0m from the point of

support of the swing. A girl stands in front of the swing. Calculate the maximum and minimum frequency she will hear (speed of sound = 330m/s,  $g = 9.8\text{m/s}^2$ ).

2. A whistle is whirled in a circle of 1m radius transverses the circular path twice per second. An observer is situated outside the circle but in its plane. What is the measured interval between the highest and lowest pitch observed if the velocity of sound is  $332\text{m/s}^2$ .

#### 4.7 Source Moving at an Angle to the Observer

When the source moves at an angle to the line joining the source and observer, the apparent frequency changes continuously. Suppose the source is moving along AB with a velocity  $v_s$  while the observer is stationary at O.

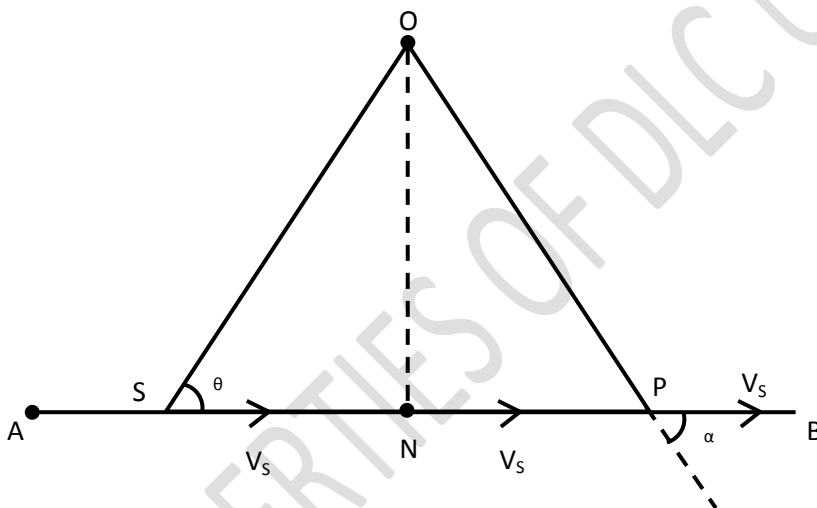

At S, the component of  $v_s$  along OS is  $v_s \cos \theta$  and is toward O.

$$\text{From, } f' = \left( \frac{v \pm v_o}{v \mp v_s} \right) f$$

$$v_o = 0$$

$$v_s = v_s \cos \theta$$

$$f' = \left( \frac{v}{v - v_s \cos \theta} \right) f$$

$$f' > f$$

At point P, the component of  $v_s$  along OP away from O, is  $v_s \cos \alpha$

$$\therefore f'' = \left( \frac{v}{v + v_s \cos \alpha} \right) f$$

$$f'' < f$$

When the source reaches N, the foot of the perpendicular from O to AB, the velocity  $v_s$  is perpendicular to ON and does not have any component towards observer. If the waves reach O shortly after, the observer hear a frequency of;

$$f''' = \left( \frac{v \pm 0}{v \pm 0} \right) f$$

$$f''' = f$$

Before the source S reaches N, it however emits waves that reach O with velocity  $v$ . If S reaches N at the same instant as the waves reaches O, the observer hears the note corresponding to the instant when the source was at S.

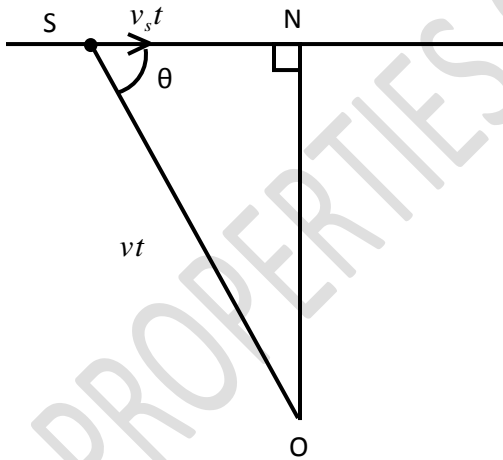

In this case  $SN = v_s t$  and  $SO = vt$  where  $t$  is time interval. Therefore,

$$\theta = \frac{v_s t}{vt} = \frac{v_s}{v}$$

The frequency of the note heard by O when S just reached N.

$$f' = \left( \frac{v}{v - v_s \cos \theta} \right) f$$



Substituting for  $\cos \theta$ ,

$$f' = \left( \frac{v}{v - v_s \frac{v_s}{v}} \right) f$$

$$f' = \left( \frac{v^2}{v^2 - v_s^2} \right) f$$

### SUMMARY

In this unit you have been introduced to the concepts of Doppler effect between a source of sound and receiver with the respect to moving

- (i) source (ii) receiver (iii) source and receiver (iv) source and receiver at an angle to each other

### Self Assessment Question

1. A boy sitting on a swing which is moving to an angle of  $30^\circ$  from the vertical is blowing a whistle which has a frequency of 1.0 KHz. The whistle is 2.0m from the point of support of the swing. A girl stands in front of the swing. Calculate the maximum and minimum frequency she will hear (speed of sound = 330m/s,  $g = 9.8\text{m/s}^2$ ).
2. A whistle is whirled in a circle of 1m radius transverses the circular path twice per second. An observer is situated outside the circle but in its plane. What is the measured interval between the highest and lowest pitch observed if the velocity of sound is  $332\text{m/s}$ .

### Study Session 5: Optics

**Expected Duration: 1 week or 3 contact hours**

#### Introduction

In this session, you will be introduced optics and its properties. Refraction, a property of optics will be given some detail treatment

## Learning Outcomes

- 5.1 Introduction to Optics
- 5.1 Refraction at Plane Surfaces
- 5.2 Law of Refraction
- 5.3 Equation of Refraction

### 5.1 Introduction to Optics

This is the study of the visible part of electromagnetic waves spectrum commonly referred to as light.

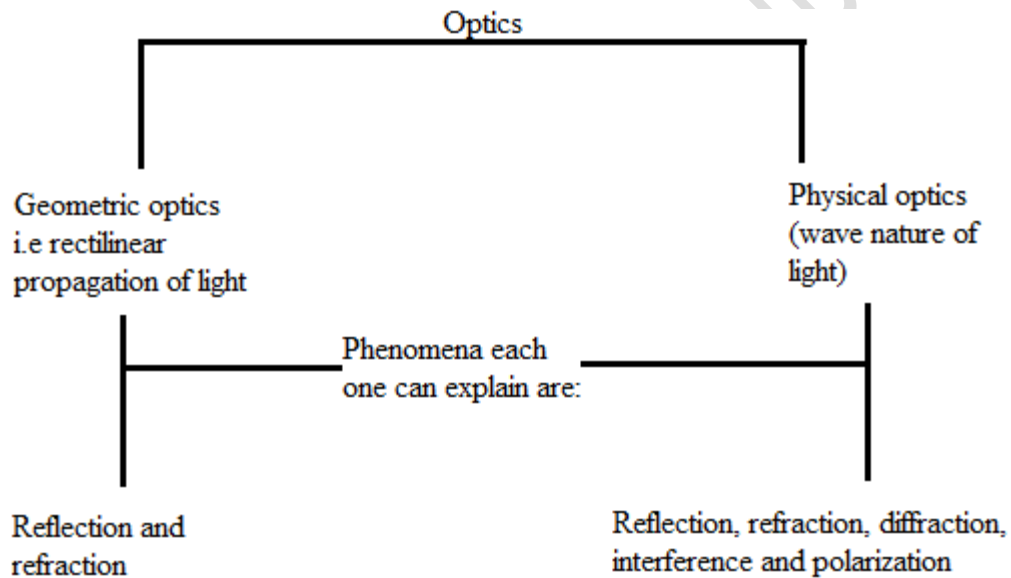

### 5.1 Refraction at Plane Surfaces

When light wave moves from one medium to another, the velocity and wavelength change and these changes may cause the light direction to change.

## 5.2 Law of Refraction

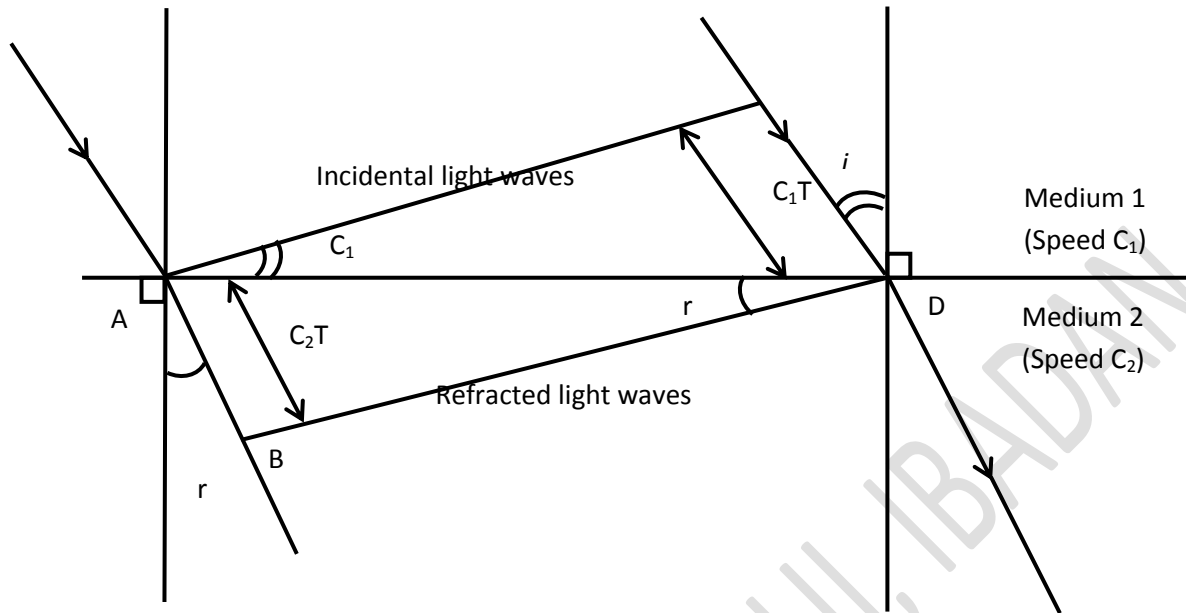

The diagram shows light travelling from one medium (in which its velocity is  $C_1$ ) across a boundary to another (in which its velocity is  $C_2$ ).

The wave fronts are all one cycle apart, so the distance moved during that time will be  $C_1T$  in medium 1 and  $C_2T$  in medium 2, where  $T$  is the period of the wave. The part of the light wave that has just hit the medium at  $A$  will move to  $B$  while the part at  $C$  will to  $D$ . Since the wave fronts ( $AC$  and  $BD$ ) are always perpendicular to the rays ( $AB$  and  $CD$ ), two simple right-angled triangles are formed and these can be used to relate the incident and refracted angles ( $i$  and  $r$ ) respectively.

$$\sin i = \frac{C_1 T}{AD} \text{ (triangle } ACD)$$

$$\sin r = \frac{C_2 T}{AD} \text{ (triangle } ABD)$$

Eliminating  $AD$ ,

$$\frac{\sin i}{\sin r} = \frac{C_1}{C_2}$$

The ratio of the sine of incident to refracted angles is equal to the ratio of the velocities of the light wave in the two media. This ratio is a constant known as refractive index  $n_2$  that is

$${}_1\eta_2 = \frac{\sin i}{\sin r} = \frac{C_1}{C_2} \quad 5.1$$

To obtain an absolute refractive index of  $\eta$ , for a medium ray,  $p$ , a ray travelling in a vacuum and then refracted in the medium is considered. That is

$$\eta_p = \frac{\text{velocity of light in a vacuum, } c}{\text{velocity of light in the medium, } v} \quad 5.2$$

From the principle of the reversibility of light, a ray travelling from medium 2 to 1 will retrace its path but in the opposite direction. The incident and refracted rays are then swapped and the refractive index,

$${}_2\eta_1 = \frac{1}{{}_1\eta_2}$$

**Note:** when  $C_1 = C_2$ ; there is no refraction and

when  $C_1 > C_2$ ;  ${}_1\eta_2 > 1$

the light rays move towards the normal, also

when  $C_1 < C_2$   ${}_1\eta_2 < 1$ ,

the light rays move away from the normal.

### 5.3 Equation of Refraction

Three media air( $a$ ), glass ( $g$ )and water ( $w$ )are lying one on top of another. A light ray passes through them as shown in the diagram below. Show that the refractive indice (i)

$g\eta_w = g\eta_a \times a\eta_w$  (ii) the refraction in water takes place as if the glass was not there.

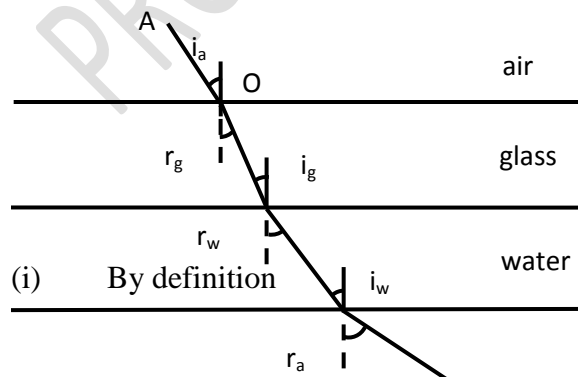

$${}^g\eta_w = \frac{\sin i_g}{\sin r_w}$$

Multiply with  $1 = \frac{\sin i_a}{\sin i_a}$

That is,

$$\frac{\sin i_g}{\sin r_w} = \frac{\sin i_g}{\sin i_a} \times \frac{\sin i_a}{\sin r_w}$$

But  $r_g = i_g$  and  $r_w = i_w$  (alternate angles are always equal)

$$\frac{\sin i_g}{\sin r_w} = \frac{\sin r_g}{\sin i_a} \times \frac{\sin i_a}{\sin r_w}$$

$$\frac{\sin r_g}{\sin i_a} = {}^g\eta_a \quad \text{and} \quad \frac{\sin i_a}{\sin r_w} = {}^a\eta_w$$

$$\therefore g\eta_w = g\eta_a \times a\eta_w$$

(ii)  $\frac{\sin i_a}{\sin r_g} = a\eta_g$

$$\sin i_a = a\eta_g \sin r_g \tag{5.3}$$

$$= a\eta_g \sin i_g \tag{5.4}$$

(alternate angles)

$$\frac{\sin i_w}{\sin r_a} = w\eta_a = \frac{1}{a\eta_w}$$

$$\sin r_a = a\eta_w \sin i_w \tag{5.5}$$

$$\sin i_a = a\eta_w \sin i_w \tag{5.6}$$

since

$$i_a = r_a \text{ (alternate angles)}$$

$$\therefore \sin i_a = a\eta_g \sin r_g = a\eta_w \sin i_w$$

In terms of absolute refractive index 5.7

$$\eta_a \sin i_a = \eta_g \sin i_g = \eta_w \sin i_w$$

Since  $\eta_a = 1$

Hence,

$$\eta_a \sin i_a = \eta_w \sin i_w$$

**The relation in equation (4) shows that when a ray is refracted from one medium to another, the boundaries being parallel,**

$$\eta \sin i = \text{constant} \qquad 5.8$$

Applications of this equation are (i) in the issue apparent depth commonly observed and (ii) optical fibre used in internet connections, which we shall consider all these after this exercise

### **SUMMARY**

In this unit you have been introduced to the concept of optics with respect to its (i) types, (ii) properties, (iii) law and equation of refraction on plane surfaces

### **Self Assessment Question**

Explain the formation of multiple images in mirrors

## **Study Session 6: Applications of Equation of Refraction**

**Expected Duration: 1 week or 3 contact hours**

### **Introduction**

In this session, you will be introduced to two applications of optics

### **Learning Outcomes**

When you have studied this session, you should be able to explain:

- 6.1 Apparent Depth
- 6.2 Total Internal Reflection
- 6.3 Optical Fibre in Communication
- 6.4 Paths of Rays in the Fibre

### **6.1 Apparent Depth**

An object such a pin inside a medium such as water or glass appears nearer the surface than is actually the case. This is due to refraction of light.

Consider an object O at a distance below the surface of a medium such as water or glass of refractive index  $\eta$ . A ray OM from O perpendicular to the surface passes straight through into the air along NS. A ray ON very close to OM is refracted at N into the air away from the normal, in a direction NT, and an observer viewing O directly overhead sees it in the position I.

Taking the angle of incidence in the glass to be  $i$  and the angle of refraction in the air as  $r$ . Then, since  $\eta \sin i = \text{constant}$  (equation 5.8), we have

$$\eta \sin i = 1 \times \sin r \quad 6.1$$

where  $\eta$  is the refractive index of the medium and 1 is the index for air.

From  $\triangle MNO$ ,  $\sin i = \frac{MN}{ON}$

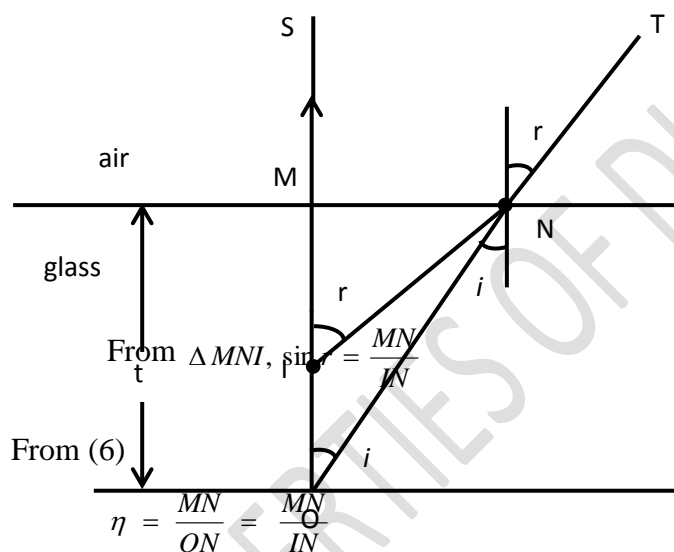

$$\therefore \eta = \frac{DN}{IN} \quad 6.2$$

Since the observer is directly above O, the rays ON, IN are very close to the normal OM. Hence, approximately.

$$ON = OM \text{ and } IN = IM$$

From (7)

$$\eta = \frac{ON}{IN} = \frac{OM}{IM} \quad 6.3$$

Since the real depth of the object O is OM and its apparent depth is IM.

Hence, equation (8) becomes

$$\eta = \frac{\text{real depth}}{\text{apparent depth}} \quad 6.4$$

Let real depth,  $OM = t$ , then, the apparent depth,  $IM = \frac{t}{\eta}$ . The displacement  $OI$  of the object, denoted by  $d$  is

$$d = \text{real depth} - \text{apparent depth}$$

That is,

$$d = t - \frac{t}{\eta}$$

$$d = t \left( 1 - \frac{1}{\eta} \right) \quad 6.5$$

### Example 6.1

A glass cylinder of refractive index 1.5 whose base is 5 cm thick contained water of refractive index 0.75 to depth of 3. To an observer looking from above, what is the apparent displacement of a coin placed under the cylinder.

$$\begin{aligned} \text{For glass, } d &= t \left( 1 - \frac{1}{\eta} \right) \\ &= 5 \left( 1 - \frac{1}{1.5} \right) \end{aligned}$$

$$\begin{aligned} \text{For water, } d &= t \left( 1 - \frac{1}{\eta} \right) \\ &= 3 \left( 1 - \frac{1}{3/4} \right) \end{aligned}$$

### 6.2 Total Internal Reflection

Before we take further example on equation(2.6). Let us quickly discuss the phenomenon of total internal reflection. It occurs when light travels from one medium to another which is optically less dense. That is, a medium which has a smaller refractive index. It can occur when light travels from glass to air, or from glass to water.



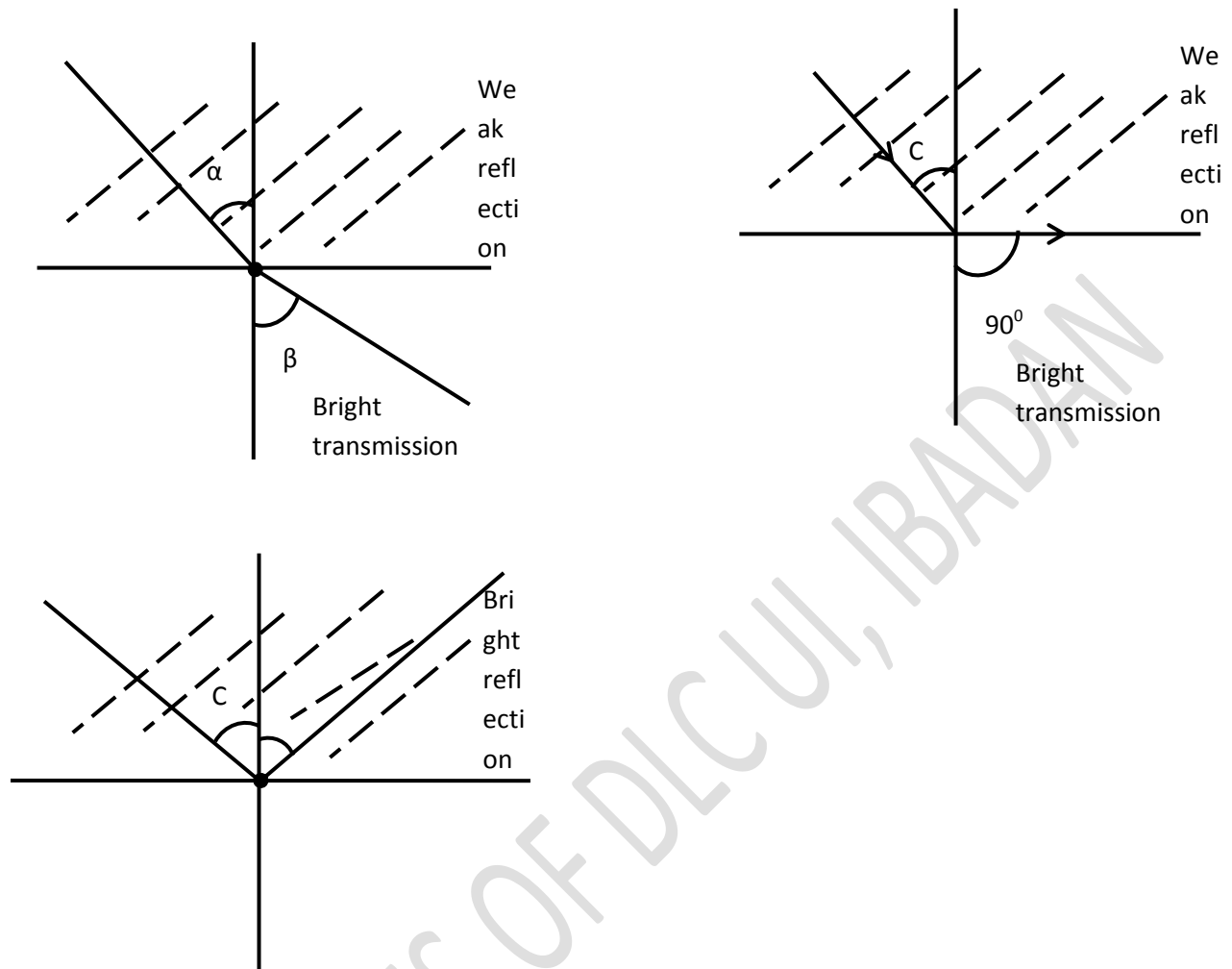

Critical angle is the angle of incidence in glass (optically dense medium) in which the angle of refraction in air (or optically less dense medium) is  $90^\circ$ . At an angle of incidence slight greater than critical angle, total internal reflection occurs in glass. Ok, let us now move to the next example

### 6.3 Optical Fibre in Communication

Light signals can travel along a very fine long glass fibres of roughly the same diameter as a human hair. This information has revolutionized the way data is transferred. This glass fibre, actually referred to as optical fibres have replaced the copper cables previously used in telecommunications.

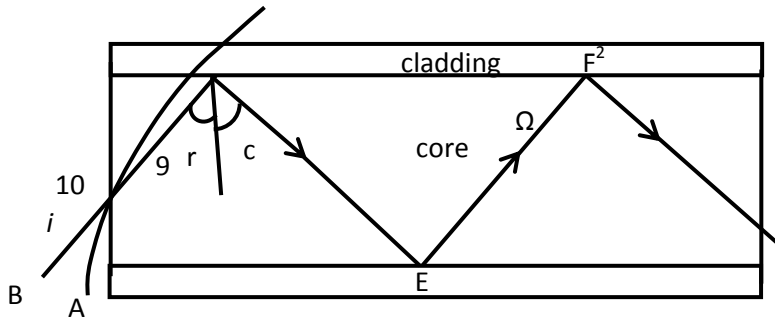

The fibre is a very fine glass rod of diameter about  $125 \mu\text{m}$  ( $125 \times 10^{-6} \text{m}$ ). After manufacture it has a central glass core surrounded by a glass coating or cladding of smaller refractive index than the core. The fibres are classified as mono-mode fibre and multimode fibre.

- (a) The **mono-mode fibre** has a very narrow core of diameter about  $5 \mu\text{m}$  ( $5 \times 10^{-6} \text{m}$ ) or less, and so the cladding is relatively big fig. (a)
- (b) The multimode fibre has a core of relatively large diameter such as  $50 \mu\text{m}$ . In one form of multimode fibre, the core has a constant refractive index  $\eta_1$  such as 1.52 from its outer to the boundary with the cladding, fig. (b). The refractive index then changes to a lower value  $\eta_2$  such as 1.48 which remains constant throughout the cladding. This is called a step-index multimode fibre, in the sense that the refractive index ‘steps’ from 1.52 to 1.48 at the boundary with the cladding.

A much more efficient fibre is the graded index multimode in which the refractive index decreases smoothly from the centre to the outer surface of the fibre.

#### 6.4 Paths of Rays in the Fibre

A ray OA entering one end at O of a step-index fibre at a large angle of incidence is refracted into the core along OP and then refracted along PQ into the cladding. At Q, the fibre surface, the ray passes into the air. In this case only a very small amount of light, due to reflection, passes along the fibre.

With a smaller angle of incidence, ray such BO is refracted in the core along OD and meets the boundary between the core and cladding at their critical angle C. In this case, using equation(5), that is.  $\eta \sin i = \text{constant}$

$$\eta_1 \sin c = \eta_2 \sin 90 = \eta_2$$

Where  $\eta_1 < \eta_2$

$$\sin c = \frac{\eta_2}{\eta_1}$$

The ray OD is totally reflected at D along DE, where it again meets the core-cladding boundary at the critical angle. At E, it is totally reflected along EF. Thus, a ray entering at one end of a fibre can travel along the fibre by multiple reflections with a fairly high light intensity.

The maximum angle of incidence in air for which all the light is totally reflected at the core-cladding fibre is the angle I in figure (c). To calculate I, use equation (5) again

$$1 \sin i = \eta_1 \sin r \quad (\text{air to core}) \quad 6.6$$

$$\eta_1 \sin c = \eta_2 \sin 90 = \eta_2 \quad (\text{core to cladding boundary}) \quad 6.7$$

$$r = 90^\circ - c, \text{ so}$$

$$\sin r = \cos c$$

$$\text{From (9), } \cos c = \frac{\sin i}{\eta_1};$$

$$\text{From (10), } \sin c = \frac{\eta_2}{\eta_1};$$

Using the trigonometric rule:  $\sin^2 c + \cos^2 c = 1$

$$\frac{\eta_2^2}{\eta_1^2} + \frac{\sin^2 i}{\eta_1^2} = 1;$$

$$\therefore \sin i = \pm \sqrt{\eta_1^2 - \eta_2^2} \quad 6.8$$

## SUMMARY

In this unit you have been introduced to applications of some concepts in optics such

- (i) apparent depth
- (ii) optical fibre

## Self Assessment Question

Explain the concept of total internal reflection

## Study Session7: Properties of Images formed by Curved Surfaces

**Expected Duration: 1 week or 3 contact hours**

### Introduction

In this session, you will be introduced to image formation by curved surfaces

### Learning Outcomes

When you have studied this session, you should be able to explain:

- 7.1 Convex (diverging) mirror
- 7.2 Concave (Converging) Mirror
- 7.3 Concave (Diverging) Lens
- 7.4 Convex (Converging) Lens.
- 7.5 Optical Formula
- 7.6 Sign Conventions in using in using optical formula

#### 7.1 Convex (diverging) mirror

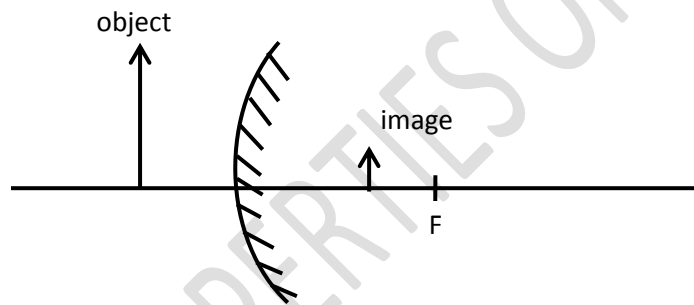

The images have common properties

- (i) Diminished (ii) Virtual (iii) Erect.

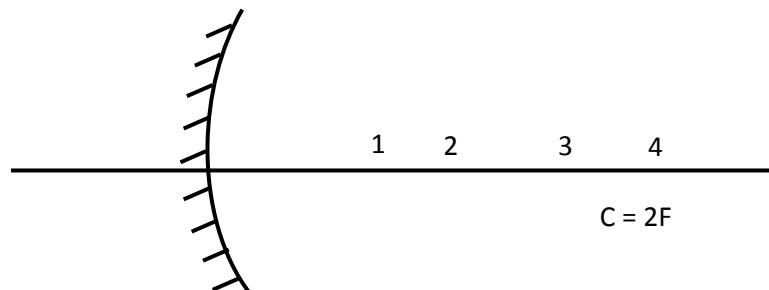

## 7.2 Concave (Converging) Mirror

Properties depend on the position of the object. Consider the objects at the positions in indicated in the diagram.

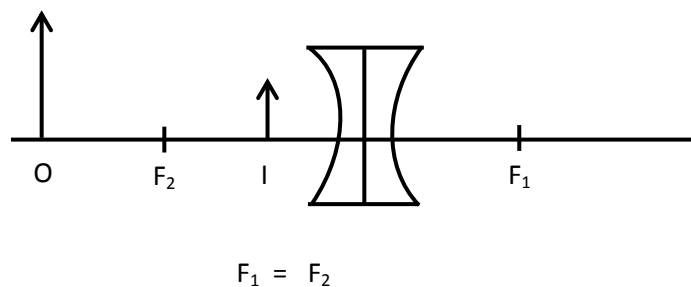

When the object is at position 1, the image is magnified, virtual and erect. When the object is at 2, the image is formed at infinity. At 3, the image formed beyond the centre of curvature (i.e.  $C = 2f$ ) and it is real and diminished. At 4, the image is at C, real and same size as object (i.e. magnification = 1).

$$\text{Magnification} = \frac{\text{image size}}{\text{object size}} = \frac{\text{image distance}}{\text{object distance}} = \frac{\text{image height}}{\text{object height}} \quad 7.1$$

## 7.3 Concave (Diverging) Lens

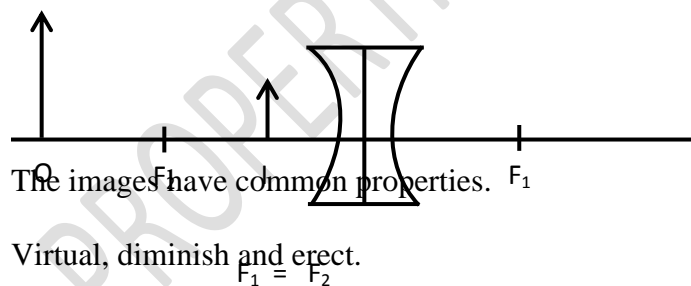

The images have common properties.

Virtual, diminished and erect.

## 7.4 Convex (Converging) Lens.

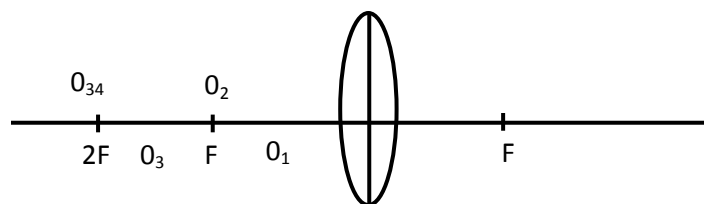

Suppose  $I_1$ ,  $I_2$ ,  $I_3$  and  $I_4$  are images due to  $O_1$ ,  $O_2$ ,  $O_3$  and  $O_4$  respectively in the figure above.

$I_1$  is virtual, erect, magnitude

$I_2$  is at infinity

$I_3$  is real, inverted, magnitude and somewhere beyond  $2F$ .

$I_4$  is real, inverted, and same size and object.

### 7.5 Optical Formula

$$\frac{1}{u} + \frac{1}{v} = \frac{1}{f} \quad 7.2$$

$$m = \frac{v}{u} \quad 7.3$$

Where  $u$  is object distance,  $v$  is image distance,  $f$  is focal length and  $m$  is magnification.

### 7.6 Sign Conventions in using in using optical formula

- (i) Virtual images distance has negative sign.
- (ii) The focal length of both convex mirror and concave lenses is negative by convention.

#### Example:

An object is placed at a distance of  $10c$  m from the pole of a converging (concave) mirror, the virtual image of the object has a magnification of 3.

- (i) Calculate the focal length of the mirror.
- (ii) Calculate the position of the object that will give a real image of the same magnification.

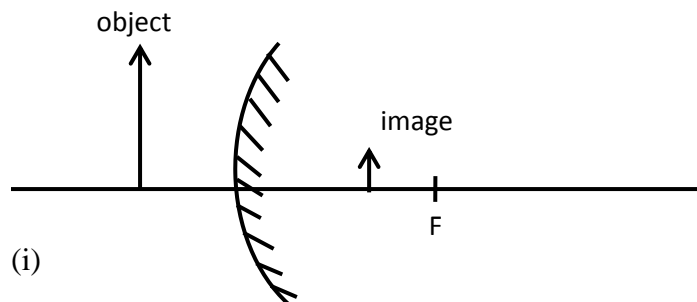

(i)

$$u = 10$$

$$m = \frac{v}{u} = 3$$

Real is positive

$$\frac{1}{u} + \frac{1}{v} = \frac{1}{f}$$

Virtual image distance is negative

$$\frac{1}{10} - \frac{1}{30} = \frac{1}{f}$$

$$\frac{1}{f} = 15\text{cm}$$

(ii)

$v = 3u$  ..... *Real Image*

$$f = 15\text{cm}$$

$$\frac{1}{u} + \frac{1}{3u} = \frac{1}{15}$$

$$\frac{4}{3u} = \frac{1}{15}$$

$$u = 20\text{cm}$$

### SUMMARY

In this unit you have been introduced to the properties of image formed by curved surfaces such as (i) concave mirror and lens (ii) convex mirror and lens

### Self Assessment Question

An object is placed at a distance 20cm away from the pole of a diverging mirror. A plane mirror placed at a distance 16cm from the object forms an image of the object which coincides with the image of the same object formed by the diverging mirror. Calculate the focal length of the diverging mirror.

PROPERTIES OF DLCCU, IBADAN



## Study Session 8: Thin Lenses

**Expected Duration: 1 week or 3 contact hours**

### Introduction

In this session, you will be introduced to some other characteristics of geometric optics

### Learning Outcomes

When you have studied this session, you should be able to explain:

- 8.1 Description of a thin Lens
- 8.2 The Lens-Makers' Formula for the Lenses
- 8.3 Power (P) of a Lens
- 8.4 Optical Instrument
- 8.5 Lens' Aberration
- 8.6 Derivation and Dispersion
- 8.7 Dispersive Power

#### 8.1 Description of a thin Lens

A thin lens is the one which has the two focal length equidistant from the optical centre.

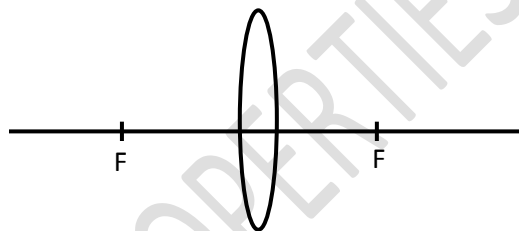

#### 8.2 The Lens-Makers Formula for the Lenses

The lens makers formula for calculating the focal length of a thin lens placed in a medium is given as:

$$\frac{1}{f} = \left( \frac{\eta_g}{\eta_m} - 1 \right) \left( \frac{1}{R_1} + \frac{1}{R_2} \right) \quad 8.1$$

where  $f$  is the focal length of the lens.

$n_g$  is the refractive index of the glass material from which the lens is made.

$n_m$  is the refractive index of the medium in which the lens is placed.

$R_1$  and  $R_2$  are radii of curvature of the lens surfaces (positive for a convex surface and negative for concave surface)

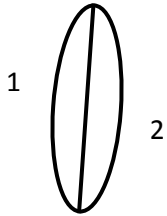

Here the two surface are convex  $R_1$  is positive and  $R_2$  is also positive

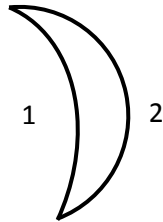

Here  $R_1$  is negative because it is concave and  $R_2$  is positive because it is convex

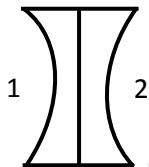

Here the two surface are concave  $R_1$  is positive and  $R_2$  is also negative

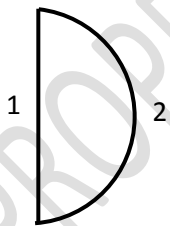

Here  $R_1$  is infinity and  $R_2$  is positive

### 8.3 Power (P) of a Lens

This is defined as the reciprocal of the focal length of the lens when the focal length is measured in metre (SI) unit.

$$P = \frac{1}{f}$$

8.2

The ability of a lens to form a sharp image is referred to as the power of a lens. The S.I. unit of this power is Dioptré. A lens with short focal length forms a sharp image compare the one with long focal length.

### Example 8.1

A lens is required to have a power of  $-2$  dioptré. The lens is made from crown glass ( $n = 1.52$ ), and the convex front has a radius of curvature of  $35\text{cm}$ . Calculate the radius of curvature of the rear surface

$$\frac{1}{f} = \left( \frac{n_g}{n_m} - 1 \right) \left( \frac{1}{R_1} + \frac{1}{R_2} \right)$$

$$-2 = \left( \frac{1.52}{1} - 1 \right) \left( \frac{1}{0.35} + \frac{1}{R_2} \right)$$

$$R_2 = -0.149$$

### Exercise 8.1

A lens of power  $+5$  Dioptré is placed  $50\text{cm}$  from a concave mirror of radius of curvature  $20\text{cm}$ . Light rays parallel to the axis fall on the lens. Calculate the positions of all the points on the axis (between the lens and the mirror) at which the light rays will be focused.

### 8.4 Optical Instrument

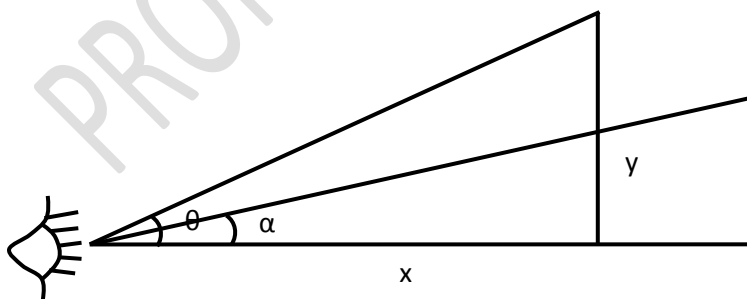

Where  $\alpha$  is the angle subtended by eye and  $\theta$  is the glancing angle

When  $\alpha < \theta$ , the object appears smaller

Angular size of an object,  $M_{\theta} = \frac{\text{size of object}}{\text{distance of object}}$

$$M_{\theta} = \frac{y}{x}$$

$M_{\theta}$  is small for small object.

The smaller the value of  $M_{\theta}$ , the less the ability of the eye to see the object. We can increase  $M_{\theta}$  either by causing the size of the object to increase or by causing its distance from the eye to decrease.

The optical instrument which serve the purpose of increasing the size of an object is known as a microscope, while the one which makes the object appear closer to the observer is known as a telescope.

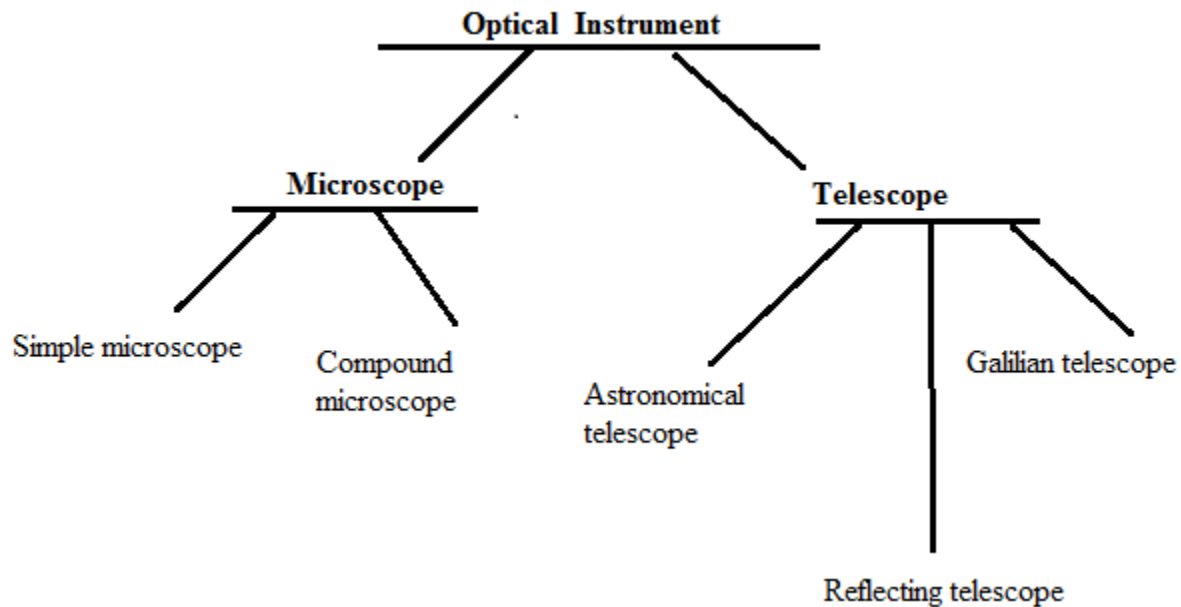

## Microscope

Simple Microscope (Magnifying Lens)

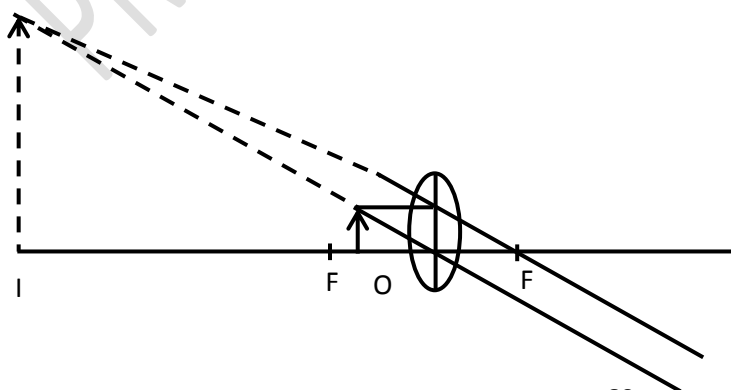

## Compound Microscope

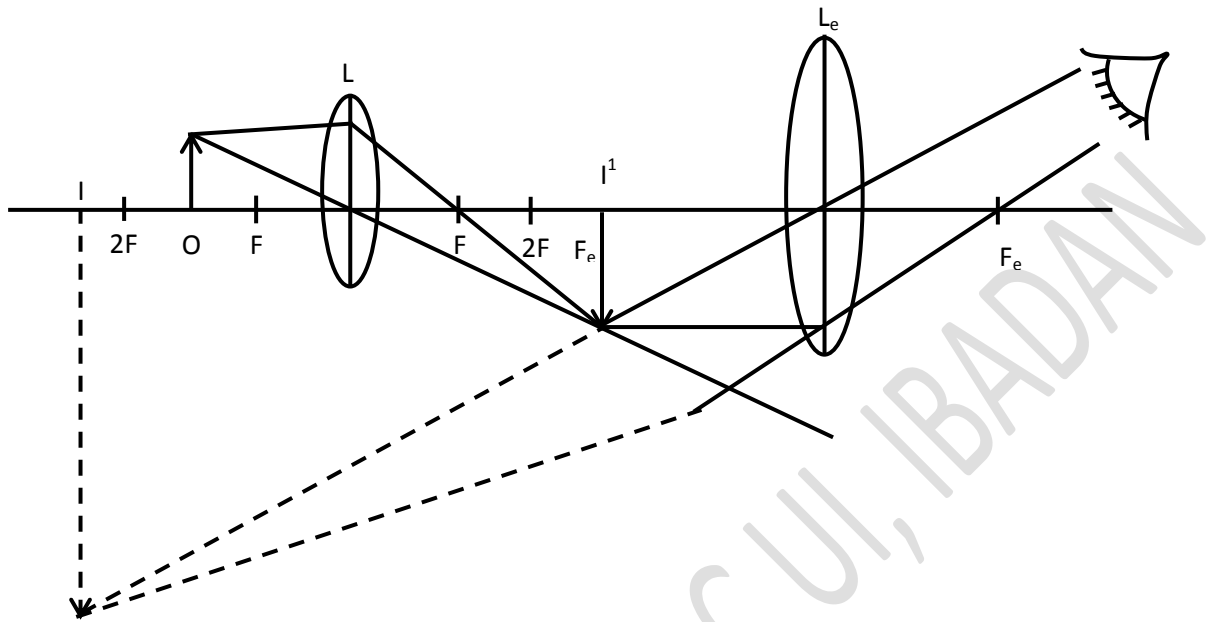

Where  $O$  is the object

$I'$  is image of object lens  $l_o$

$I''$  is image of eye lens  $l_e$

Let the object height be  $l$ , and  $M_o$ , the magnification of  $l_o$ ,  $M_e$  is magnification of  $l_e$

$$M_o = \frac{I'}{l},$$

$$I' = M_o l$$

and

$$M_e = \frac{I''}{I'}$$

$$I'' = M_e I'$$

Total magnification,  $M$

$$M = \frac{I''}{l} = \frac{M_e}{I'/M_o}$$

$$\therefore M = M_o M_e$$

## Telescope: Astronomical Telescope

$$f_o > f_e$$

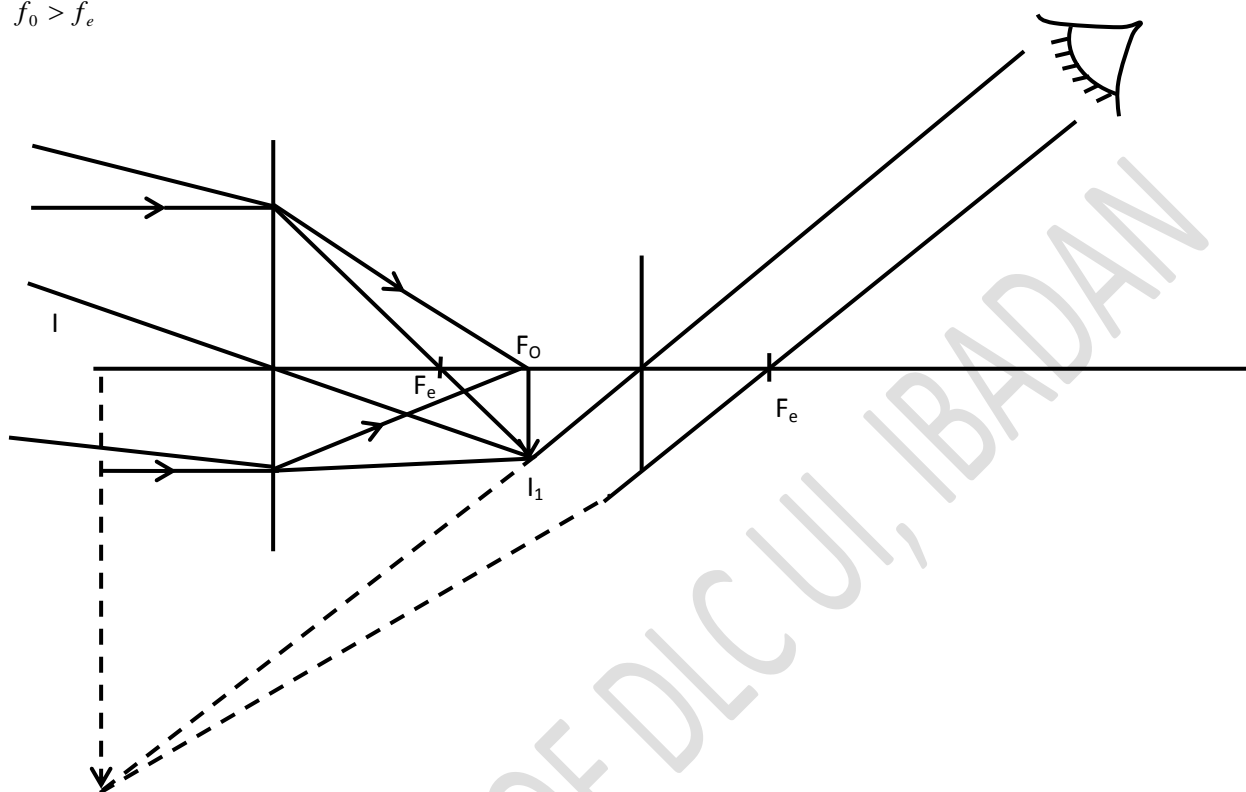

### 8.5 Lens' Aberration

Aberration is the inability of a lens to form sharp images of an object. There are two major types viz: (i) spherical aberration (ii) chromatic aberration.

**Spherical Aberration:** The inability of a lens to bring to a common focus parallel rays that are close and those that are not close to the principal axis of the lens.

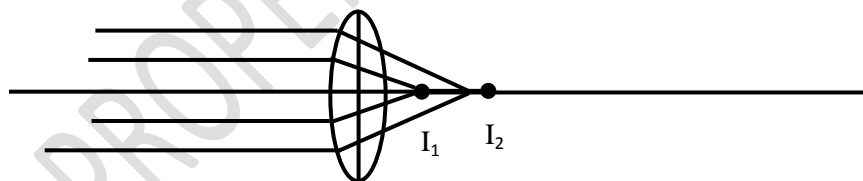

In this case a blurred image is formed

Spherical aberration is prevented by using an opaque material with a central aperture to cover the lens surface. This will allow only rays that are close to the principal axis to enter the lens.

**Chromatic Aberration:** This is inability of a lens to bring to a common focus light rays of different frequencies or wavelengths.

It is prevented by grinding glass materials of different refractive indices to make a lens. The reciprocal of the focal length of the resulting lens is equal to the sum of the reciprocals of the focal lengths of the constituting materials.

## 8.6 Deviation and Dispersion

A narrow beam of visible light passing through a glass prism will bend toward the normal on entering and away from the normal on leaving. These two refractors cause the light to deviate from its original path. Also, the refractive index for light in glass changes with frequencies so that higher frequencies (e.g. blue) were deviated more than lower frequencies (e.g. red). This means that, light (light waves) of different frequencies travel at different speeds when passing through a dispersive medium. The waves are therefore, refracted by different degrees depending on their frequencies . Hence, what we see is the spectrum of colours of different frequencies. This separation of frequencies is called **dispersion**.

## 8.7 Dispersive Power

Red and blue are the extreme colours in the visible in the spectrum of light. The dispersive power,  $\omega$  of a particular material such as glass for these two colours is defined by the ratio.

$$\omega = \frac{\eta_b - \eta_r}{\eta - 1} \quad 8.3$$

where  $\eta_b$  and  $\eta_r$  are the refractive index for blue and red respectively and  $\eta$  is the refractive index of the glass for yellow light.

### Example

For a certain crown glass  $\eta_b = 1.52$ ,  $\eta_r = 1.510$  and  $\eta = 1.517$ . Calculate the dispersive power

$$\omega = \frac{\eta_b - \eta_r}{\eta - 1} = 0.02$$

## SUMMARY

In this unit you learnt (i) how to use lens-makers' formula, (ii) applications of lenses in optical instrument (iii) lens aberration and (iv) dispersion of light

### Self Assessment Question

1. Read sight defects and their corrections using lens.
2. The refractive index of glass for the red light is 1.510 and that of blue 1.521. Light from the hydrogen lamp is incident at angle  $30^\circ$  on glass-air boundary. Calculate the angle of refraction for the red and blue light (Hint:  $n_a \sin i_a = n_g \sin i_g$ )



## Study Session 9: Introduction to Atomic Models

### Introduction

In this session, you will be introduced to different models of atom

### Learning Outcomes

When you have studied this session, you should be able to explain:

- 9.1 Atomic Structure
- 9.3 Thomson's Model
- 9.4 Rutherford's Model
- 9.5 Equations of the Rutherford's Model
- 9.6 The Structure of Rutherford's Atomic Model
- 9.7 Limitations of Rutherford's Model
- 9.8 Discovery of Electron

### Expected Duration: 1 week or 3 contact hours

#### 9.1 Atomic Structure

Atomic structure are explained using models. These models are used to help understand the properties of matter. If they do that successfully they are good models. As scientists learnt more about the physical and chemical properties of matter they modify the current model to explain the new observations. A real good model allows the scientists to make productions and test them in experiments. It is wrong to think that old models are wrong while the latest ones are right. In one sense, they are all right in that they can explain certain concept. In another sense, they are all wrongs because of their limitations. Each model is most appropriate in a particular situation so the most important thing to understand about a model is its limitations.

## 9.2 Mechanical Atomic Model

This explain atom as the smallest indivisible particle of an element. This model can explain chemical combinations (e.g. law of constant proportion, law of multiple proportion, Gay-lussals law) and the kinetic theory..

## 9.3 Thomson's Model

Thomson's discovery of the electron in 1897 ended the idea of the 'uncultable or indivisible atom.' He showed that electrons have a tiny mass (about  $1/1840$  of the mass of hydrogen ion) and present in atoms of all elements. He suggested a model in which the bulk of the atom consists of a positive material, in which electrons are embedded. In this model the negative charge of the electrons balances the positive charge in the rest of the atom, and the structure is held together by electrostatic forces. Ions are formed when atoms gain or lose electrons. This model, in addition to explaining all of the same thing as mechanical model can also explain electrovalent bonding in terms of electrical forces. Lack of detail about atomic structure makes it however to fail in tackling the problems of atomic spectral and radioactivity.

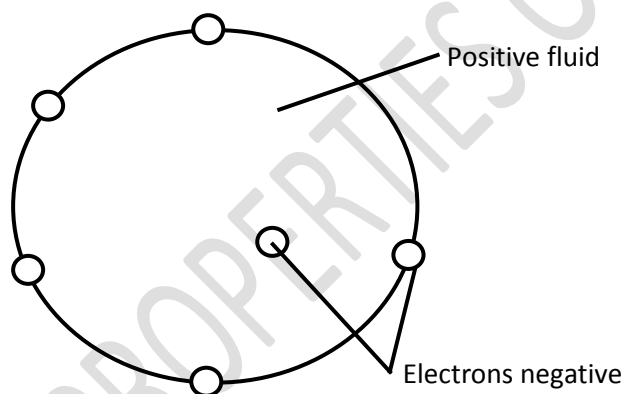

**Figure 9.1: Thormson's Atomic Model**

## 9.4 Rutherford's Model

Rutherford in his famous experiment by two of his research students (Geiger and Marsden) direct collimated (parallel) beams of alpha particles at very thin pieces of gold foil (figure 1.2 ) expecting the alpha particles to penetrate with a very small angular deflection granting any deflection at all (fig. 1.3), because they knew how

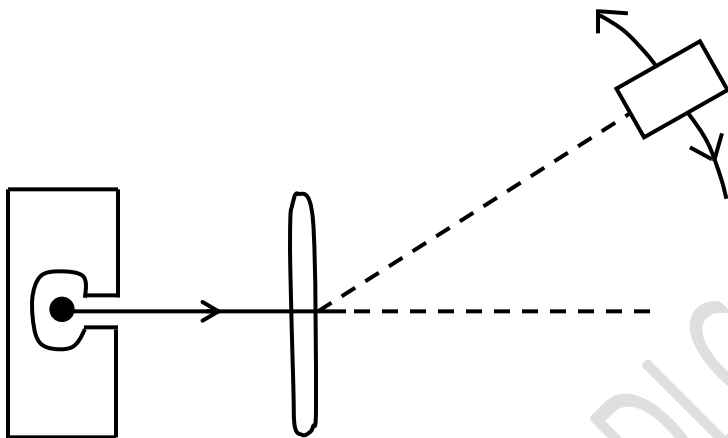

Figure 9.2: Bombardment of gold-foil with alpha particles

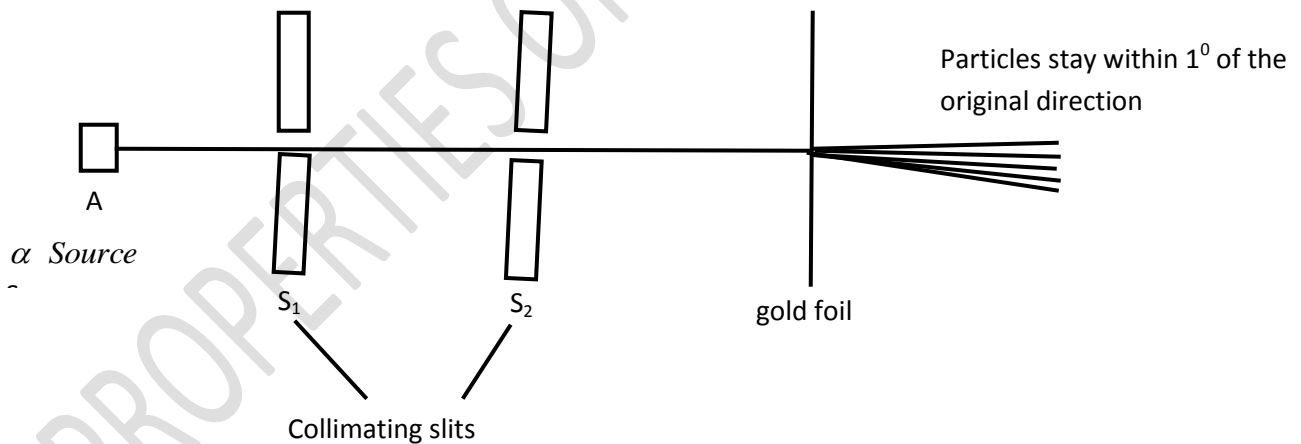

Figure 9.3: Alpha particles passing through the gold foil within 1° of the original direction

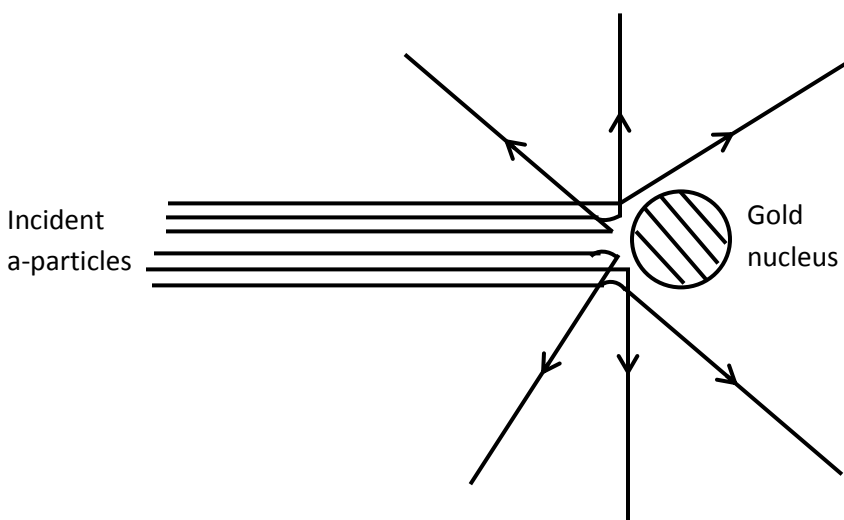

Figure 9.4: Few of the alpha particles were scattered by the gold foil at large angles

well alpha particles penetrated air and various thickness of absorbers. They obtained the following result by measuring the rate of arrival of alpha particles at different scattering angles.

- (1) The vast majority of the alpha-particles did penetrate the foil with little or no deflection (figure 9.3)
- (2) A few were deflected through large angles (figure 9.4)
- (3) A very small proportion  $\approx 1/18000$  bounced back off the foil.

These results certainly meant that atoms were not uniform as Thomson had suggested: If they were all the alpha - particles will behave as shown in figure 9.3. Those that bounced back must have been repelled by something with large mass and also of high charge. Rutherford called this 'something' Nucleus. Rutherford made the following conclusions from his experiment.

- (1) Most of atom is virtually empty space (a very small ratio alpha particles were deflected at large angle).
- (2) At the centre of atom is a nucleus, which has most of the mass of the atom and all of its positive charge.
- (3) Electrons orbit the nucleus much like planets orbit the sun and bond to the nucleus by an electrostatic attraction.
- (4) Alpha particles scatter from the nucleus because of the electrostatic repulsion between like charges.

By directing beam of collimated alpha particle on foils made from different elements, it was confirmed that the number of charges on the nucleus increases with the atomic number of

the element in the periodic table. Hydrogen has a single positive charge on the nucleus; helium has two and so on. Nucleus seems to be made up of smaller particles some of which are positively charged. However, although a helium nucleus has double the charge of a hydrogen nucleus, it has four times its mass, so helium nucleus is not just two hydrogen nuclei that stick together. This positively charged particles are called proton.

Rutherford suggested that the nucleus might contain yet another particle to make up the mass. This particle would have about the same mass as a proton and no electric charge. It was named the neutron.

and, it was finally discovered by another. Rutherford's student, James Chadwick. Protons and neutron collectively made up the nucleus.

Rutherford derived a mathematical equation based on the assumptions above predict how the alpha particles would be scattered from the foil.

### 9.5 Equations of the Rutherford's Model

The nearest distance the alpha particle comes to the nucleus in the Rutherford's experiment, also known as distance of closest approach or the impact parameter  $b$  is related to the scattering angle  $\theta$  by the formula.

$$\text{Cot} \left( \frac{\theta}{2} \right) = \frac{4\pi \epsilon_0 b T}{Z e^2} \quad 1.1$$

where  $T$  is kinetic energy of the alpha particle

$e$  is electronic charge

$z$  is atomic number of the target material (gold).

The number of alpha particle scattered through an angle  $\theta$  in one minute is given by the equation.

$$N(\theta) = \frac{7.9 \times 10^{-24}}{T^2 \sin^4(\theta/2)} \quad 1.2$$

#### Example 9.1:

Calculate the impact parameter for a beam of alpha particles whose scattering angle is  $46^\circ$  and kinetic energy of 10 eV given that atomic number of gold is 79

$$b = \frac{Z e^2 \text{Cot}(\theta/2)}{4\pi \epsilon_0 T} = \frac{79 \times (1.6 \times 10^{-19})^2 \times \text{Cot}(46/2) \times 9 \times 10^9}{10 \times 1.6 \times 10^{-19}} = 2.68 \times 10^{-8} \text{ m}$$

**The following are some other useful terminology.**

**Nuclide:** a particular type nucleus, e.g. carbon – 12, uranium – 235 etc

**Isotopes:** nuclei of the same element with different number of neutrons e.g. carbon – 12 and carbon – 14.

**Alpha Particle:** a molecular nucleus ejected in radioactive decay.

**Ion:** charged atom.

### 9.6 The Structure of Rutherford's Atomic Model

The structure of a nuclide can be written as  ${}^A_Z X$  where A is mass number and z is atomic number (or number of proton). Number of neutron,  $N = A - Z$ . Adding the orbiting electrons to the picture, Rutherford's planetary atom is given the sketch below:

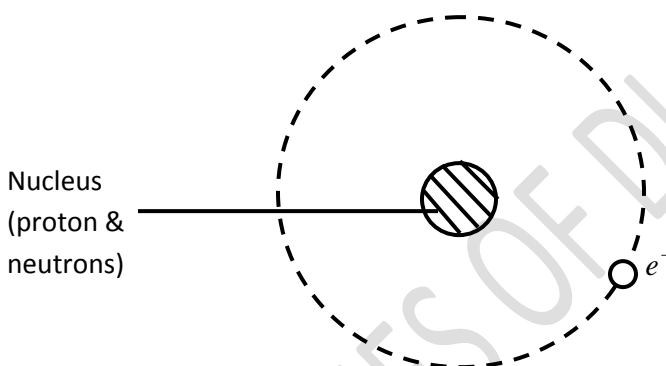

Figure 9.5: Rutherford's Planetary Atomic Model

If this were to be drawn to scale for Helium – 4, the electrons will be several hundred metres away.

### 9.7 Limitations of Rutherford's Model

According to Maxwell's theory, all accelerating charges should radiate. Electrons orbiting nucleus have centripetal acceleration.

1. So as the electrons revolve round the nucleus they radiate their energy away. Such electrons will therefore draw closer to the nucleus until they are captured by the nucleus and the atom collapsed.

2. If the electrons are radiating energies continuously then all matter ought to give a continuous spectrum whether it is cold or hot, charged or neutral but this is not so.
3. The model could not explain the existence of the line spectra when an electron in an atom makes a transition.

## 9.8 Discovery of Electron

Crookes in an attempt to produce low pressure in sealed glass tubes began to use very narrow tubes to conduct electricity at low pressures. A pattern of glowing gas observed in the glass. He also noticed that the glass behind the anode also glow (Figure 9.6). It was assumed that the glass must have been hit by stream of rays from cathode. This ray was initially called cathode ray.

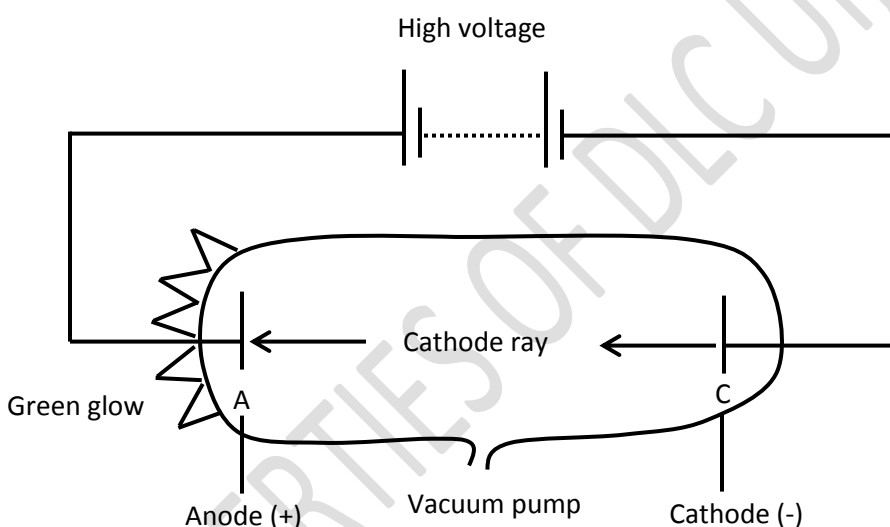

Figure 9.6: Crooke's tube

J. S. Thompson carried out some experiments on this ray to see if they were negatively charged. He was able to establish the following:

1. cathode rays transfer energy, momentum, and mass (they turned a light paddle placed in their path).
2. cathode rays transfer negative charge (i.e. they are deflected toward a positive plate).
3. the charge-to-mass ratio  $e/m$  (i.e. specific charge) of cathode rays is much larger than that for hydrogen ions.

4. cathode rays have the same proportions whatever gas is used in the tube, whatever metal is used as the anode.

Thompson's hypothesis reveals that cathode rays are charged particles and are present in atoms of every element (1, 2 & 4). The specific charge ( $e/m$ ) for cathode rays was found to be 1840 times greater than that of hydrogen ion. Assuming each cathode ray carried a charge equal to that of hydrogen ion (the smallest known charge), the mass of each charged particle must be about  $\frac{1}{18400}$  times that of hydrogen ion. By this argument, Thompson concluded that this charged particle otherwise known as electron is a subatomic. Nowadays, cathode ray (electrons) are produced through the process known as **thermionic emission**. It is similar to evaporation. Cathode is heated to increase the thermal energy of its electrons. This enables them to leave the surface more easily. These free electrons are accelerated in electric field between the cathode and anode. A hole is bored in the anode for the electron to stream into a near vacuum. The whole device is called electron gun.

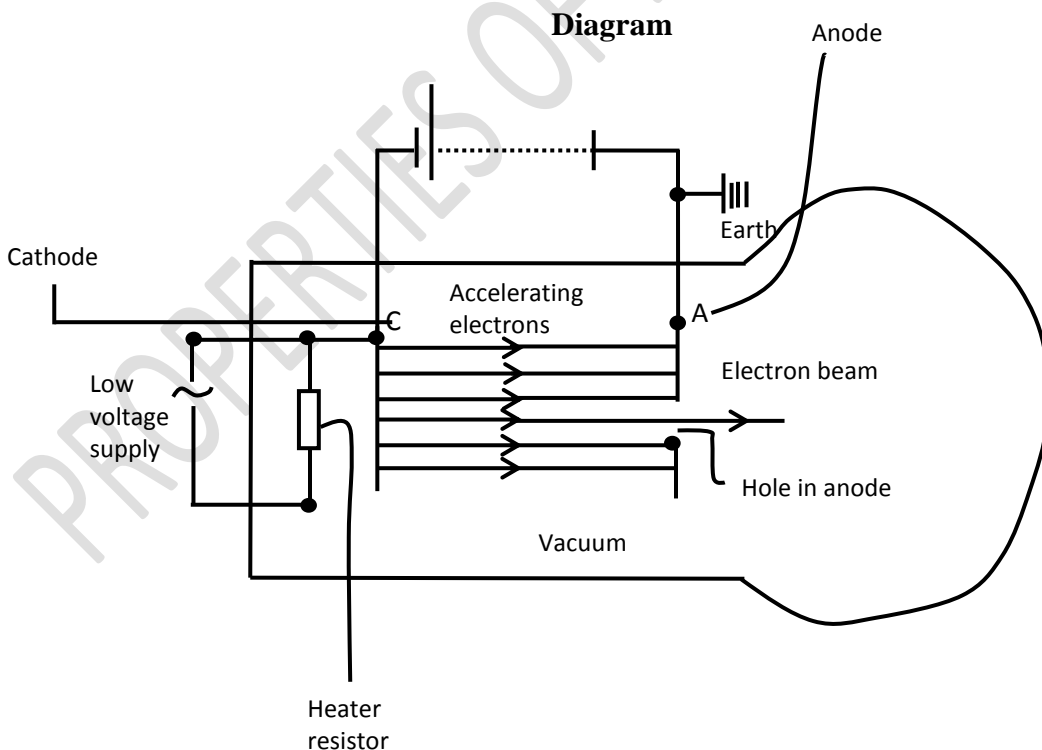

Figure 9.7: Electrons beam



### Exercise

Compare and contrast evaporation and thermionic emission

What are the other methods by which electrons can be made to leave the surface of metal?

The speed with which the electrons emerge from the hole in the anode depends on the potential difference  $V$  between the cathode and anode. Assuming that electrons leaving the cathode by thermionic emission have negligible speeds. Calculate the electron speed for accelerating voltage of  $V = 1000V$ .

Work done on an electron as it moves from cathode to anode is

$$W = eV$$

The electron is in a vacuum so this work creates kinetic energy.

$$\frac{1}{2}mv^2 = eV$$

$$v = \sqrt{\frac{2eV}{m}}$$

For accelerating voltage of  $1000V$ , the electron velocity is,

$$v = 1.9 \times 10^7 \text{ m/s.}$$

This is about 6% of the speed of light ( $c$ ). If the accelerating voltage is much higher, the value of  $v$ , will be closed to  $c$ . Equation \*\*\*\* will not be valid in such situation.

**The large value of Specific charge ( $e/m$ ) is a crucial piece of evidence that confirmed that cathode rays consists of streams of subatomic, negative charged particles (electrons).**

Specific charge ( $e/m$ ) can be measured in a deflection tube by balancing electric and magnetic forces on moving electrons as they pass through a region of crossed electric and magnetic field.

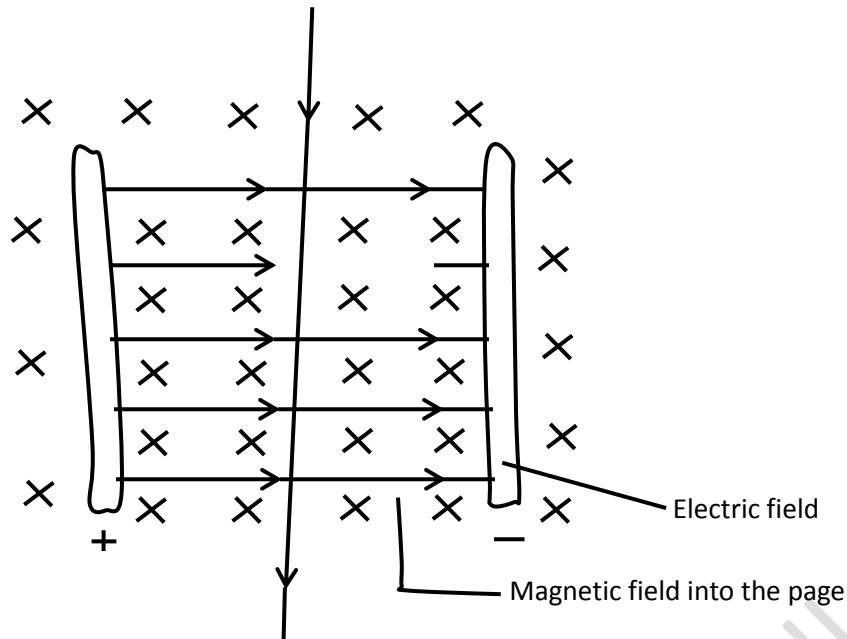

Figure 9.8: electrons passing through a crossed field of electric and magnetic fields

The electrostatic force on the electron

$$F_{es} = eE$$

where  $E$  is electric field intensity and  $e$  is the electric charge i.e.  $F_{es}$  is acting in opposite direction to the lines of electric field.

The magnetic force,

$$F_m = Bev$$

where  $B$  is magnetic field strength,  $v$ , is electron velocity. The direction of  $F_m$  is given by Fleming's left-hand rule.

If these force are equal and opposite to one another, electron beam is undeflected, and

$$eE = Bev$$

$$v = \frac{E}{B}$$

But from previous example

$$v = \sqrt{\frac{2eV}{m}}$$

Equating (1) and (2)

$$v^2 = \frac{2eV}{m} = \frac{E^2}{B^2}$$

$$\text{Hence } \frac{e}{m} = \frac{E^2}{2V B^2}$$

If the electric field is between parallel plates separated by a distance  $d$  with a potential difference  $V_p$  between them, then  $|E| = \frac{V_p}{d}$

$$\text{so that } \frac{e}{m} = \frac{V_p^2}{2V B^2 d^2}$$

everything on the right hand can be measured,  $V$  and  $V_p$  with voltmeter,  $d$  with ruler, magnetic field is usually set up using Helmholtz coils with magnetic field strength given by

$$B = \frac{0.72 \mu_0 NI}{r}$$

where  $N$  is the no. of turns in the coil,  $I$  is current in the coil and  $r$  is the radius of the coil.

### SUMMARY

In this unit you have been introduced to different types of atomic models with respect to (i) mechanical, (ii) Thomson and (iii) Rutherford models. Discovery of electron was also discussed

### Self Assessment Question

1. An electron beam is accelerated through a potential difference of 250V. The electrons then enter a region of uniform magnetic field, perpendicular to the beam, of strength 0.02 T.
  - (a) Calculate the speed and kinetic energy of the electrons when they leave the electrons gun.
  - (b) If the anode and cathode are separated by 1.6cm, calculate the acceleration of an electron between these electrodes.
  - (c) An electric field is now applied so that the electrostatic force opposes the magnetic force on the electrons and the beam goes straight. Calculate the size of the electric field.
2. Calculate the magnetic field strength required to deflect electrons into a circle of radius 8cm if the accelerating voltage in the electron gun is 400V.
3. Outline the properties of cathode rays.
4. Uses of Cathode Rays

## Study Session 10: Hydrogen Spectrum and Bohr's Model of Atom

### Introduction

In this session, you will be introduced to the concept of quantization of atom

**Expected Duration: 1 week or 3 contact hours**

### Learning Outcomes

When you have studied this session, you should be able to explain:

- 10.1 The Hydrogen Spectrum
- 10.2 Quanta
- 10.3 Bohr's Model
- 10.4 Electrons (matter) as Wave
- 10.5 Bohr's Quantum Condition
- 10.6 Bohr's Radii and Energies for Hydrogen Atom
- 10.7 Success and Limitations of Bohr's Model
- 10.8 Electron Cloud Model
- 10.9 Wave-Particle Duality of Light

#### 10.1 The Hydrogen Spectrum

Each element is known to display a unique spectrum which serves to 'fingerprint' it. For gases and vapour at low pressures the spectrum is a line spectrum consisting of distinct lines of various colours.

Investigation on hydrogen, the simplest element, reveal that the lines in the spectrum are grouped into five distinct series identified as the Lyman, Balmer, Pascher, Brackett and Pfund series. The lines in each series get closer together in the short wavelength end of the spectrum converging towards a limit.

obtaining an empirical formula for

For the **visible region** of the spectrum, Balmer succeeded in the wave number  $\bar{K}$  of the lines in the series as

$$\bar{K} = \frac{1}{\lambda} = R_H \left[ \frac{1}{2^2} - \frac{1}{n^2} \right], n = 3, 4, 5, 6, \dots$$

where  $\lambda$  is the wavelength and  $R_H$  is a constant

Similar formulas obtained by other authors are given below.

For the Lyman series (in the **ultra-violet region**)

$$\bar{K} = \frac{1}{\lambda} = R_H \left[ \frac{1}{n^2} - \frac{1}{n^2} \right], n = 2, 3, 4, \dots$$

For Pascher series (in the infrared region)

$$\bar{K} = \frac{1}{\lambda} = R_H \left[ \frac{1}{3^2} - \frac{1}{n^2} \right], n = 4, 5, 6, \dots$$

For the Brackett series (in the infrared region)

$$\bar{K} = \frac{1}{\lambda} = R_H \left[ \frac{1}{4^2} - \frac{1}{n^2} \right], n = 5, 6, 7, \dots$$

For the Pfund series (in the deep infrared region)

$$\bar{K} = \frac{1}{\lambda} = R_H \left[ \frac{1}{5^2} - \frac{1}{n^2} \right], n = 6, 7, 8, \dots$$

## 10.2 Quanta

All hot bodies radiate. A black body is an ideal radiator. The spectrum of radiation from a black body is shown below.

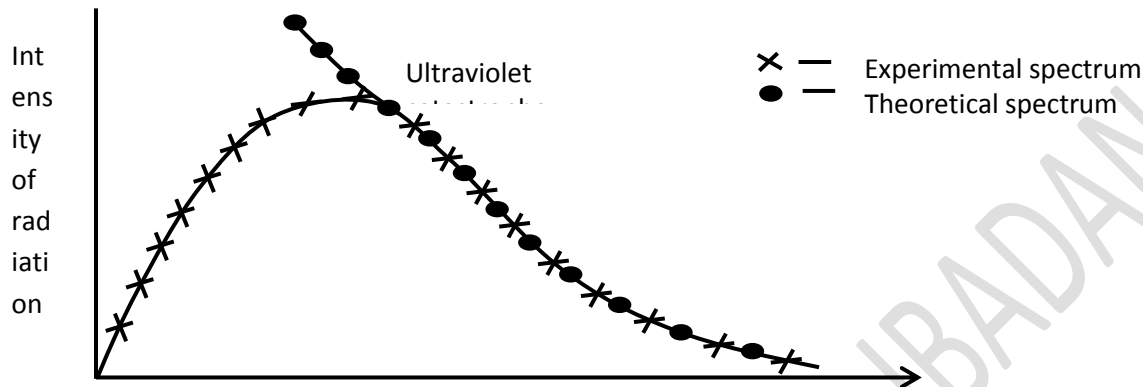

Figure 10.1: spectrum of radiation from blackbody

The spectrum of radiation from experiments was well known by nineteenth century physicists, the problem was to derive the spectrum from Mechanics and electromagnetism (which, at that time, are physics concepts that could explain 'everything'). The equations they got could only fit the long wavelength end of the spectrum. At the short wavelength end, their equations predicted that infinite amount of energy would be radiated (fig). This was called ultraviolet catastrophe.

The theory of this classical physics assumed that thermal energy is distributed among atoms, making them to oscillate and this will result in emission of electromagnetic waves.

Max Planck solved the problem and got an accurate equation for the spectrum by assuming that the oscillators responsible for the radiation only have discrete energies.

$$E = nhf \quad n = 0, 1, 2, \dots$$

The oscillator of frequency  $f$  can only have zero energy or multiple of a fixed amount (quantum),  $hf$ ,  $h = 6.626 \times 10^{-34} \text{ Js}$  is known as Planck constant. The shorter wavelengths correspond to higher frequencies. Oscillators responsible to radiation in the shorter wavelength of the spectrum need more energy to be activated. Since thermal energy is randomly distributed, the chance that those higher frequencies oscillator will get enough energy to start vibrating

compare with those with low frequency is much smaller. Thus, if energy is quantized, the higher frequencies are turned off and their intensities drop down to zero rapidly.

### 10.3 Bohr's Model

Bohr modified Rutherford's model by adding Max Planck's quantum conditions as follows:

1. Electrons occupy permissible (i.e. allowed) orbits around the nucleus of an atom. Each of the orbit corresponds to certain radius and energy. The possible energy levels and corresponding principal quantum numbers,  $n = 1, 2, 3, \dots$  are shown in the (Figure 10.2).

The energy increases upwards as the levels come closer to each other. Atomic collapse is prevented because there are no allowed states between these energy levels and because the lowest, or ground state is not at zero energy. An electron at any of these levels does not radiate.

2. When electron jumps from a higher to a lower energy level (or orbit), it emits radiation in definite amounts (i.e. in quanta). Also, electron absorbs radiation when it jumps from a lower to a higher energy level. The atom is said to be in an excited state. The electron stays momentary (about  $10^{-8}$ s) at this excited state before taking a jump (a dive) to any lower allowed energy levels (Figure 10.2)

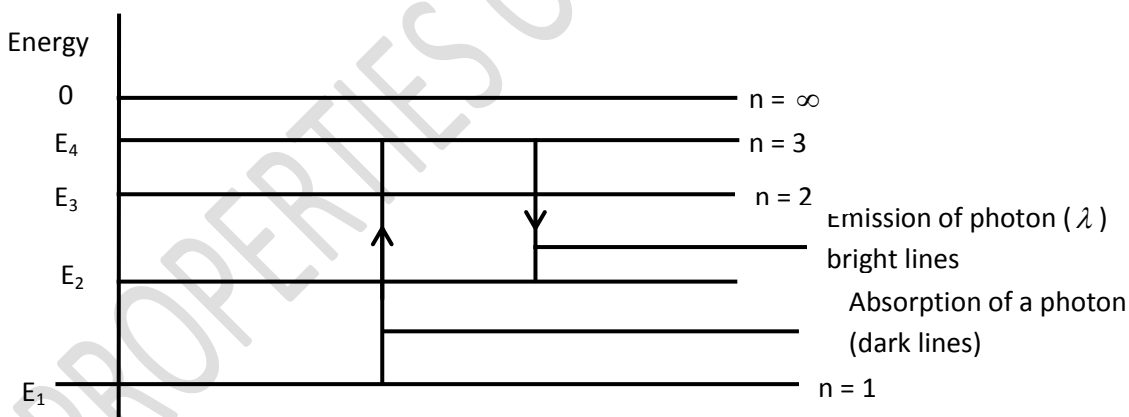

Figure 10.2: electronic transition

For this quantum jump

$$\Delta E = \text{photon energy} = hf$$

$$f = \frac{\Delta E}{h}$$

$$\text{where } \lambda = \frac{c}{f} = \frac{hc}{\Delta E}$$

Atoms of a particular element have a characteristic structure of energy level so that there are only certain energy jumps the electrons can make. This implies that the photons emitted from atoms have certain well-defined wavelengths. For instance, if a gas of atoms is excited, by whatever means, it emits a characteristic line spectrum. This is a distinct and bright line of definite wavelength on a dark background.

3. The angular momentum is conserved (constant) in these allowed or permissible orbits.

$$\text{The angular momentum, } L = mvr = \frac{nh}{2\pi}$$

where  $m$  = mass,  $v$  = velocity,  $r$  = radius of the orbit,  $n$  = an integer,  $h$  = planck's constant. Note that  $n$ ,  $h$  and  $\pi$  are constants. This will be explained shortly but let me quickly make a detour to discuss the work of Prince L.V.P.R de Broglie, who treated electron (a subatomic particle) as wave.

#### 10.4 Electrons (matter) as Wave

Prince L.V.P.R de Broglie proposed that electrons like light might also have a wave-like character. The de Broglie argument ran roughly like this suppose

- (1) Wave-like properties of light are fixed by a wavelength,  $\lambda$
- (2) Particle-like properties are fixed by a linear momentum,  $P$ .

This can be linked for a photon by using Einstein's mass energy relation and his formula for photon energy.

$$\text{Photon energy, } E = hf = mc^2$$

$$\text{Photon momentum, } P = mc$$

$$\text{So, } p = \frac{hf}{c} = \frac{h}{\lambda}$$

$$\text{Or, } \lambda = \frac{h}{p}$$

Davisson and G.P. Thompson (the son of J. J. Thompson) carried out experiment to show that electrons can be diffracted in the same way that x-ray (an electromagnetic wave) of the same de



Broglie wavelength is diffracted. De Broglie got Nobel Price in 1929 for his work. while Davisson and G.P. Thompson shared 1937 Nobel Prize for their experimental work also.

### Exercise 10.1

What is the de Broglie wavelength of an electron which has been accelerated through a potential difference of 1000V?

### 10.5 Bohr's Quantum Condition

If electrons in atoms can act like waves, they might behave like standing waves that are formed on a string stretched and fixed at both ends when plucked. Only certain wavelengths 'fit' the string and reinforce, others cancel out. This leads to a set of discrete frequencies that give fundamental frequency and harmonics of the string. These fundamental frequency and harmonics of electron waves form the ground state and excited states respectively.

In Bohr's circular orbits, the condition for electron wave to reinforce as standing waves is simply that their wavelength fit the circumference of the orbit a whole number of times. The principal quantum number  $n$  is the number of complete waves that fit the circumference of the orbit.

Hence, Bohr's quantum condition states that:

$$2\pi r = n\lambda$$

$$\lambda = \frac{h}{p} = \frac{h}{mv}$$

$$2\pi r = \frac{nh}{mv}$$

But angular momentum,  $L = mvr$

Hence,  $L = mvr = nh/2\pi$

This is Bohr's third condition

### 10.6 Bohr's Radii and Energies for Hydrogen Atom

Bohr quantized hydrogen atom by assuming that electron moves in a circular orbit of radius  $r$ .

The electrical force between the proton and electron is balanced by centripetal force.

$$\text{i.e. } \frac{m_e v^2}{r} = \frac{e^2}{4\pi\epsilon_0 r^2} \dots\dots\dots (1)$$

From Bohr's postulate

$$m_e v r = \frac{\pi h}{2\pi} \dots\dots\dots (2)$$

Eliminating  $v$  from (1) and (2)

$$r = \frac{\epsilon_0 h^2 n^2}{\pi m_e e^2} \dots\dots\dots (3)$$

$r$  is the radii of the permitted orbits in hydrogen atom. The value of  $r$  for  $n = 1$  is called first Bohr radius.

$$r = 0.529 \times 10^{-20} n^2 \dots\dots\dots (4)$$

The first Bohr radius =  $0.529 \times 10^{-10} = 0.529 \text{ \AA}$

The potential energy of electron (-e) at dist  $r$  from proton (+e)

$$E_p = \frac{-e^2}{4\pi \epsilon_0 r} \dots\dots\dots (5)$$

The kinetic energy of the electron is

$$E_k = \frac{1}{2} m_e v^2 = \frac{e^2}{8\pi \epsilon_0 r} \dots\dots\dots (6)$$

The total energy of the electron is

$$E = E_p + E_k = \frac{-e^2}{8\pi \epsilon_0 r} \dots\dots\dots (7)$$

Eliminate  $r$  in (7) by using (3)

$$E_n = \frac{-m_e e^4}{8 \epsilon_0^2 h^2 n^2} \dots\dots\dots (8)$$

$n = 1, 2, 3, \dots$

The energy  $E_1$  corresponding to  $n=1$  is called the ground state energy, and is the numerically the energy required to ionize a hydrogen atom.

$$E_n = \frac{-k}{n^2} \dots\dots\dots (9)$$

$$E_1 = -k = -13.6 \text{ eV} \dots\dots\dots (10)$$

The possible frequencies which a hydrogen atom can radiate when the electron jumps from a higher level  $E_{n1}$  to a lower level  $E_{n2}$  are therefore given by

$$hf = E_{n2} - E_{n1} \dots\dots\dots (11)$$

That is,

$$f = \frac{m_e e^4}{8\epsilon_0^2 h^3} \left[ \frac{1}{n_1^2} - \frac{1}{n_2^2} \right] \dots\dots\dots(12)$$

$$\bar{K} = \frac{1}{\lambda} = \frac{f}{c} = \frac{m_e e^4}{8\epsilon_0^2 h^3 c} \left[ \frac{1}{n_1^2} - \frac{1}{n_2^2} \right]$$

$$\bar{K} = \frac{1}{\lambda} = \frac{f}{c} = R_H \left[ \frac{1}{n_1^2} - \frac{1}{n_2^2} \right] \dots\dots\dots(13)$$

where  $R_H$ , Rydberg constant, it has the numerical value of  $1.0973731 \times 10^7 \text{ m}^{-1}$ . Equation 13 is of the same form as Balmer's empirical formula. Bohr's predicted the existence of other hydrogen series which were later observed.

**Example 10.1**

An electron in a hydrogen atom makes a transition from the ground level to the third level. If the energy for the ground level is -13.6 eV, calculate the (a) energy for the third level. (b). excitation energy (c). frequency of emitted photon

(a).  $E_3 = \frac{E_1}{n^2} = \frac{-13.6}{3^2} = -1.51 \text{ eV}$

(b). Excitation energy =  $E_3 - E_1 = -1.51 - (-13.6) = 12.09 \text{ eV}$

(c).  $E = hf$

$$f = \frac{E}{h} = \frac{12.09 \times 1.6 \times 10^{-19}}{6.63 \times 10^{-34}} = 2.92 \times 10^{15} \text{ Hz}$$

**Example 10.2**

If electrons of energy (i). 6.0 eV, (ii). 16.0 eV collide with the atoms of hydrogen in the ground state, how much energy will the electrons retain in each case?

**Solution**

(i). The energy required for the first excited state is  
 $-3.39 \text{ eV} - (-13.6 \text{ eV}) = 10.21 \text{ eV}$

Since 6.0 eV is less than this minimum energy required for transition, no transition can occur. The colliding electrons retain their energy, and the collision is perfectly elastic.

(ii). The colliding electron in this case can retain a maximum of  $16.0 \text{ eV} - 13.6 \text{ eV} = 2.4 \text{ eV}$

The ionization energy is numerically equal to 13.6 eV for hydrogen. Since 16.0 eV exceeds this value, transition from  $n = 1$  to  $n = 2$  atom absorbs  $-3.39 - (-13.6)$ , that is 10.21 eV and the colliding electron retains 5.79 eV. For transition from  $n = 1$  to  $n = \infty$

### 10.7 Success and Limitations of Bohr's Model

#### Success

1. It offers explanation for the structure of the hydrogen atom.
2. It offers explanation for the existence of line spectral of the hydrogen atom.
3. provides evidence for the existence of energy level in the atom.

#### Limitations

1. It could not interpret the details of spectra of complex atoms because he used a simple atom of hydrogen for his model.
2. There is no theoretical basis for selecting the allowed orbits or states.
3. The radius of an orbit could not be checked experimentally.
4. The motion of the nucleus was not considered.

### 10.8 Electron Cloud Model

In this model, the electrons are observed to form cloud around the nucleus in definite orbits. The actual electron arrangement around the atom has theoretically observed using wave mechanical concept. This model gives better results than Bohr's model.

In this model, each electron does not have a definite orbit. However, there is the highest probability that the electron will be found at the radius of the Bohr orbit.

#### Limitations

1. It is abstract
2. It involves difficult mathematics (wave mechanics).

### 10.9 Wave-Particle Duality of Light

Thomas Young, Davisson and G.P. Thompson had shown that light and electron could be diffracted (more recently a whole atom) and their wavelength wave measured. However, photoelectric effect could not be explained using wave theory. It needed Einstein's photon

hypothesis, a particle a continuous wave. Going by the augment of De Broglie, the dilemma is called wave-particle duality.

### **SUMMARY**

In this unit you learnt about quantization of atom with respect to Bohr model and Planck law. The concept wave-matter duality and various types of hydrogen spectral were also introduced

### **Self Assessment Question**

List all the limitations of each atomic model

PROPERTIES OF DLC UI, IBADAN

## Study Session 11: X-ray and Nuclear Stability

**Expected Duration: 1 week or 3 contact hours**

### Introduction

In this session, you will be introduced to production and properties X-ray. Nuclear stability will also be treated

### Learning Outcomes

When you have studied this session, you should be able to explain:

- 11.1 X-Ray Production
- 11.2 Properties of X-rays
- 11.3 Nuclear stability

#### 11.1 X-Ray Production

When electron beams in the cathode rays tube crashes into something, most of the electrons' kinetic energy is changed to thermal energy and photons of electromagnetic radiation as the electrons decelerate. The thermal energy raised the temperature of the target. The X-ray is the highly penetrating photon of electromagnetic radiation produced when electrons in a cathode rays tube accelerates through a potential difference in excess of 1KV and are slowed down or stopped by an obstacle

X-ray will have its maximum energy when all the kinetic energy of electron beam is given to or converted to a photon. Since this energy cannot be greater than the energy the electron has just before the collision. There will be a maximum frequency and a minimum wavelength associated with the X-ray that is produced. The continuous spectral of x-ray given off with wavelength having any value from this minimum up is called Bremsstrahlung or braking radiation.

X-ray was discovered accidentally by Roentgen 1895 while studying cathode rays in a cold cathode ray tube (Crooke's tube). The cold cathode X-ray tube developed by Roentgen has been replaced by the Coolidge tube shown in figure 11.1. This is a hot-cathode tube operating at a very high voltage ( $\approx 1000$  KV).

The electron released from the heated cathode is accelerated by this extra-high tension voltage to strike the target. Intense heat is generated in the target during the impact, therefore, a material with a high melting point (i.e tungsten) is used. The heat in the target is conducted away in small X-ray tube models with the aids of a large copper block and radiated away by the cooling fins. In large models of the X-ray tube, the copper block is cooled by circulating water through a pipe embedded in it.

One advantage that Coolidge tube has over Roentgen is that the X-ray intensity and hardness (penetrating power) can be controlled separately by varying the heater current and the accelerating voltage respectively. The X-ray tube generates X-ray photons more efficiently if the accelerating electrons are brought suddenly to rest by the target. Therefore, the target materials must be one of high density. Tungsten is commonly used as the target on account of its high density and high melting point.

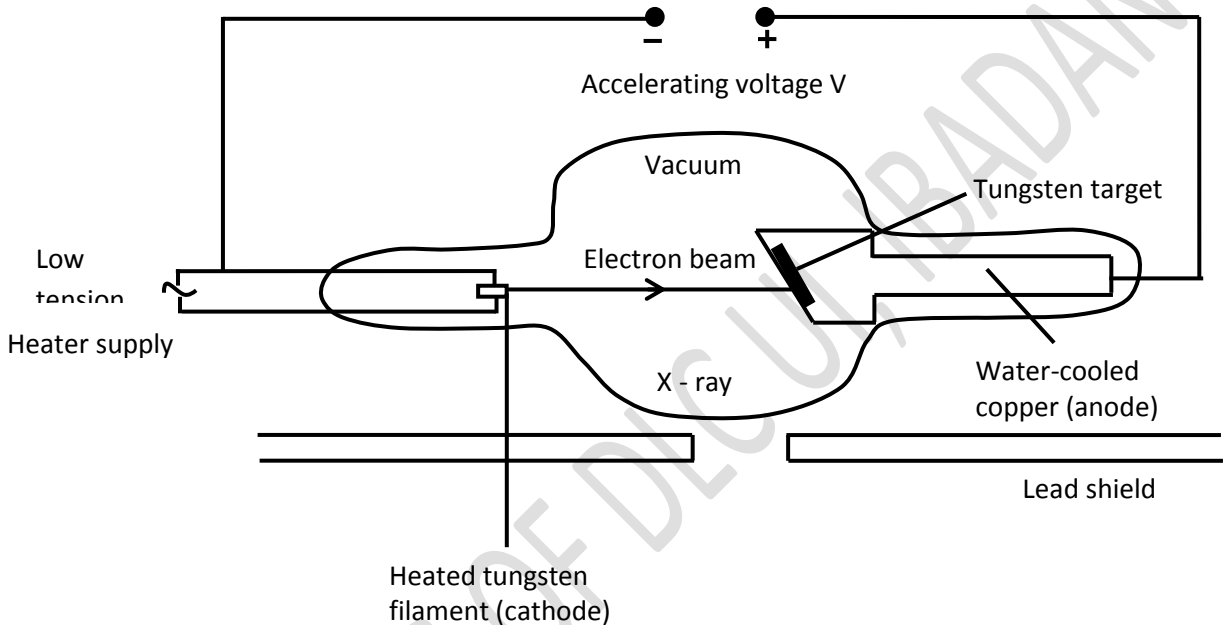

Figure 11.1: X-ray tube

## 11.2 Properties of X-rays

1. They affect photographic plates
2. They cause some materials to glow
3. They travel in straight lines (i.e. they produced well-defined shadows)
4. They penetrate low density media (e.g flesh, wood etc)  
This forms the basis for their usage as diagnostic tools in medicine and industry
5. They produce intense ionization and therefore can cause damage to tissues over-exposed to them
6. They can be diffracted by crystal lattice
7. They are not deflected by either electric or magnetic fields
8. In vacuum (i.e empty space) X-rays travels at the speed of light
9. They can release secondary electrons when beamed on metals. This phenomenon is known as photoelectric effect which is also exhibited by ultra-violet radiation

### Example

Calculate the minimum wavelength of X-rays emitted for an x-ray tube in which the accelerating voltage is 80 KV.

K.E of cathode rays = photon energy + heat produced during collision

$$K.E = hf + E_H$$

But  $E_H = 0$  when  $\lambda_{min}$

$$eV = hf$$

$$f = \frac{hc}{\lambda} = eV$$

$$\lambda_{min} = \frac{hc}{eV} = \frac{3.0 \times 10^8}{1.6 \times 10^{-19}} \times \frac{6.6 \times 10^{-34}}{80 \times 1000} = 1.5 \times 10^{-11} \text{ m}$$

### 11.3 Nuclear stability

The nucleus is at the centre of an atom and contains nucleons— proton and neutron. The force binding the nucleons together is known as the nuclear force. It is a short-range attractive force which overrides the coulomb force of repulsion between any two like charges like protons. Nuclear force decreases as particle size increases and it vanishes when particle size exceeds  $5.0 \times 10^{-15} \text{ m}$ . Nucleons then tend to pull apart and is said to be unstable. Heavy elements therefore stand the risk of nuclear instability on account of their long nuclear diameters. All elements with atomic number greater than 82 have unstable nuclei. Since there are light elements that are unstable, there must be some other factors other than their nuclear diameters which determine nuclear instability.

### SUMMARY

In this unit you are introduced to X-rays with respect to its (i) production and (ii) properties. Nuclear stability was also introduced

#### Self Assessment Question

1. The voltage across an x-ray tube is 200 kilovolt. The minimum wavelength of X-rays produced is  $5.0 \times 10^{-12} \text{ m}$ . What minimum percentage of the energy of cathode rays is lost as heat due to collisions with the anode target?
2. The electrons striking the inside surface of a TV tube have been accelerated through a potential difference of 20 KV. How are you protected from these X-rays when you watch the TV?



## Study Session 12: Radioactivity

**Expected Duration: 1 week or 3 contact hours**

### Learning Outcomes

#### Introduction

In this session, you will be introduced to radioactivity with respect to its types, equations, half-life and mean life

When you have studied this session, you should be able to explain:

- 12.1 Types of Ionizing Radiations
- 12.2 Radioactive Decay equation
- 12.3 Activity
- 12.4 Half-life
- 12.5 Mean Life Time

#### 12.1 Types of Ionizing Radiations

This is the process by which unstable nuclear undergo spontaneous disintegration by emitting ionizing radiation until they attain stability. The radiations commonly emitted in this process are named alpha ( $\alpha$ ), beta ( $\beta$ ) and gamma ( $\gamma$ ) radiations.

Alpha particles are the most strongly ionized while gamma radiation is the least. The more strongly ionizing a radiation is, the more the more easily it dissipates its energy when passing through a material and the more easily it can be stopped.

Radioactivity is not affected by physical and environmental conditions like temperature and pressure (i.e. it is not a transformation due to phase change). It does not also depend on chemical bonding.

Both  $\alpha$  and  $\beta$  are charged particles. A beta particle is a type of fast electron ( ${}^{-1}_0e$ ) emitted from the nucleus of an atom when a neutron changes to proton. That is,

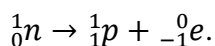

An alpha particle is a helium nuclide ( $He^{2+}$ ). That is, a helium atom that has lost its two electrons. That is,

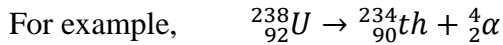
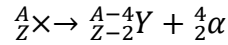

Gamma rays electromagnetic waves with frequencies greater than those of x-rays. They accompany  $\beta$  and  $\alpha$  decay. The  $\alpha$  and  $\beta$  decays leave the nuclei in excited state. Gamma is necessary for atoms to return to its ground state. That is

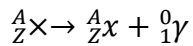

## 12.2 Radioactive Decay equation

Based on the following assumptions:

- (i). Decay is completely random.
- (ii). the rate of decay is directly proportional to the number of unstable nuclei present, a mathematical equation,

$$N(t) = N_0 e^{-\lambda t}$$

was obtained. Where  $N_0$  is number of initial populations of unstable nuclei,  $N(t)$  is number of nuclei that remains,  $\lambda$  is decay constant, it is a measure of how fast the disintegration takes place and  $t$ , is time. The statistical prediction based on this exponential model (**equation**) will be accurate if it is applied to a large population. Otherwise, the uncertainties significantly increase for small population

## 12.3 Activity

This is defined as the number of disintegrations per unit seconds

That is,

$$A(t) = \left| \frac{dN(t)}{dt} \right|$$

From  $N(t) = N_0 e^{-\lambda t}$

$$\frac{dN(t)}{dt} = \lambda e^{-\lambda t}$$

$$A(t) = \left| \frac{dN(t)}{dt} \right| = \lambda N_0 e^{-\lambda t}$$

11.1

But  $N_0 e^{-\lambda t} = N(t)$

Hence

$$A(t) = \left| \frac{dN(t)}{dt} \right| = \lambda N(t)$$

At time  $t=0$ ,  $A(t=0) = \lambda N(t=0) = \lambda N_0$

$$A_0 = \lambda N_0$$

From equation 11.1

$$A(t) = A_0 e^{-\lambda t}$$

Thus, the activity,  $A(t)$ , also satisfies the decay equation. The S.I unit of the activity is Becquerel (Bq).  $1\text{Bq}=1$  disintegration per second.

Another unit is Curie (Ci).  $1\text{Ci}=3.7 \times 10^{10}\text{Bq}$ .

## 12.4 Half-life

This is the time taken by a radioactive material (i.e a large number of unstable nuclei) to decay to half of its original amount. In another sense, it is the time at the end of which half of the radioactive material have decayed.

$$N(t) = N_0 e^{-\lambda t}$$

$$\text{when } t = T_{1/2}, N(t) = \frac{N_0}{2}$$

$$\frac{N_0}{2} = N_0 e^{-\lambda T_{1/2}}$$

$$\frac{1}{2} = e^{-\lambda T_{1/2}}$$

$$\ln\left(\frac{1}{2}\right) = \ln e^{-\lambda T_{1/2}}$$

$$-\ln 2 = -\lambda T_{1/2}$$

$$T_{1/2} = \frac{\ln 2}{\lambda} = \frac{0.693}{\lambda}$$

## 12.5 Mean Life Time

Mean life time( $\tau$ ): this is the time it takes a radioactive material to decay to  $1/e$  of its original amount or the average time a single nucleus of radioactive materials exists before undergoing disintegration. Mean life time is also known as life expectance

$$N(t) = N_0 e^{-\lambda t}$$

$$\text{when } t = \tau, N(t) = \frac{N_0}{e}$$

$$\frac{N_0}{e^1} = N_0 e^{-\lambda \tau}$$

$$\frac{1}{e^1} = e^{-\lambda \tau}$$

$$\ln\left(\frac{1}{e}\right) = \ln e^{-\lambda \tau}$$

$$-\ln e = -\lambda \tau \ln e$$

$$-1 = -\lambda \tau$$

$$\tau = \frac{1}{\lambda}$$

$T_{k/l}$  is defined as the time taken for a radioactive material to disintegrate to  $l/k$  of its original amount. Where  $l$  and  $k$  are integer and  $k < l$

$$N(t) = N_0 e^{-\lambda t}$$

$$\text{when } t = T_{k/l}, N(t) = \frac{k}{l} N_0$$

$$\frac{k}{l} N_0 = N_0 e^{-\lambda T_{k/l}}$$

$$\frac{k}{l} = e^{-\lambda T_{k/l}}$$

$$\ln \frac{k}{l} = \ln e^{-\lambda T_{k/l}}$$

## 12.6 Sundry Examples

### Example 12.1

Two radioactive elements P and Q initially have the same masses. If their half-lives are 10 and 5 years respectively, what is the ratio of their masses (P:Q) after 20 years?

Let initial masses of P and Q be M

$T_{\frac{1}{2}}$  for P is 10 years

∴ The mass of P after 20 years is,

$$M \xrightarrow{10 \text{ years}} \frac{M}{2} \xrightarrow{20 \text{ years}} \frac{M}{4}$$

∴ The mass of Q after 20 years is,

$$M \xrightarrow{5 \text{ years}} \frac{M}{2} \xrightarrow{10 \text{ years}} \frac{M}{4} \xrightarrow{15 \text{ years}} \frac{M}{8} \xrightarrow{20 \text{ years}} \frac{M}{16}$$

$$\therefore \text{the ratio } P:Q = \frac{M}{4} : \frac{M}{16} = 4:1$$

**Example 12.2:**

A radioactive substance has a half-life of 25hrs. How long would it take a certain quantity of the substance left somewhere at time t=0 to decay to 20% of its original quantity?

$$N(t) = N_0 e^{-\lambda t}$$

at t = 0, quantity of radioactive substance is  $N_0$

$$\text{at } t = ?, N(t) = \frac{20}{100} N_0 = \frac{N_0}{5}$$

$$\frac{N_0}{5} = N_0 e^{-\lambda t}$$

$$\frac{1}{5} = e^{-\lambda t}$$

$$\text{but } \lambda = \frac{0.693}{T_{\frac{1}{2}}}$$

$$\lambda = \frac{0.693}{25}$$

$$\text{hence, } \frac{1}{5} = e^{-\frac{0.693}{25}t}$$

$$-\ln 5 = -\frac{0.693}{25}t$$

$$\ln 5 = \frac{0.693}{25}t$$

$$t = \frac{25 \ln 5}{0.693} = 58.06 \text{ hrs}$$

### Example 12.3

Living wood contains radioactive  $^{14}\text{C}$  which is in equilibrium with  $^{14}\text{C}$  in the atmosphere. A 1.00Kg sample of Carbon from living wood gives an average of 255 disintegrations per second/Kg.

A sample of  $2.00 \times 10^{-22}$  Kg of Carbon from the wood of an ancient building gives an average of 270 disintegrations per minute/Kg. The half-life of  $^{14}\text{C}$  is 5570yrs. Calculate the age of the building in years.

The ancient building wood has the same activity as the living wood when it was also a living wood.

$$\text{i. e. } A(t = 0) = A_0 = 255 \text{ per second/Kg}$$

The present activity of the ancient wood

$$A(t) = 270 \text{ /min/Kg}$$

$$A(t) = \left( \frac{270}{60 \times 2 \times 10^{-2}} \right) \text{ /sec/Kg}$$

$$\text{since } T_{\frac{1}{2}} \text{ of } ^{14}\text{C} = 5570 \text{ yrs}$$

$$\lambda = \frac{0.693}{5570} = 1.2442 \times 10^{-4}$$

$$A(t) = A_0 e^{-\lambda t}$$

$$\frac{270}{60 \times 2 \times 10^{-2}} = 255 e^{-\frac{0.693}{5570}t}$$

$$\frac{270}{60 \times 2 \times 10^{-2} \times 255} = e^{-\frac{0.693}{5570}t}$$

$$\frac{60 \times 2 \times 10^{-2} \times 255}{270} = e^{\frac{0.693}{5570}t}$$

$$1.133 = e^{1.2442 \times 10^{-4}t}$$

$$t = \frac{\ln 1.133}{1.2442 \times 10^{-4}}$$

$$t = 1005.74 \text{ yrs}$$

#### Example 12.4

The half-life of  $^{226}\text{Ra}$  is 1620 yrs.

- How long will it take for 9/10 of a given sample of radium to decay?
- How many disintegrations will occur in 5g of the element in 1 day?

(NB. Atomic weight of  $^{226}\text{Ra}$  is 226 Kg/Kmol; Avogadro's number  $N_a$  is  $6.02 \times 10^{26}$  atoms/Kmol)

- If 9/10 of the atom decayed, then 1/10 is left.

Let the time the material has to decay to 1/10 of its original amount be  $T_{1/10}$ .

$$N(t) = N_0 e^{-\lambda t}$$

$$\frac{1}{10} N_0 = N_0 e^{-\lambda T_{1/10}}$$

$$-\ln 10 = -\lambda T_{\frac{1}{10}}$$

$$T_{\frac{1}{10}} = \frac{\ln 10}{\lambda}$$

$$\text{but, } T_{\frac{1}{2}} = \frac{0.693}{\lambda}$$

$$1620 = \frac{0.693}{\lambda}$$

$$\lambda = \frac{0.693}{1620} \text{y}^{-1} = 4.2778 \times 10^{-4} \text{y}^{-1}$$

$$T_{\frac{1}{10}} = \frac{\ln 10}{4.2778 \times 10^{-4}} = \frac{2.3026}{4.2778 \times 10^{-4}} = 5383 \text{yrs}$$

b) 226Kg of  $^{226}\text{Ra}$  contains  $6.02 \times 10^{26}$  atoms.

$$1 \text{kg of } ^{226}\text{Ra} = \frac{6.02 \times 10^{26}}{226} \text{ atoms}$$

$$5 \text{g i.e. } 0.005 \text{kg} = \frac{6.02 \times 10^{26}}{226} \times 0.005 \text{ atoms} = N(t)$$

Activity i.e. disintegration per unit time

$$A(t) = \lambda N(t) = 4.2778 \times 10^{-4} \text{y}^{-1} \times \frac{6.02 \times 10^{26}}{226} \times 0.005$$

$$A(t) = \frac{4.2778 \times 10^{-4}}{365} \times \frac{6.02 \times 10^{26}}{226} \times 0.005$$

$$A(t) = 1.561 \times 10^{16} \text{ disintegrations/day}$$

## SUMMARY

In this unit you are introduced to radioactivity with respect its (i) definition, (ii) types and (iii) equations



**Self Assessment Question**

Two radioactive substances P and Q each of mass 250g were properly mixed together at time  $t=0$ . P has a half-life of 30.0hrs. Exactly 3 days later, the masses of the mixture (both P and Q) was found to be 150g. What would be the mass of this mixture after another one day?

(Note: The substances could not react with each other)

PROPERTIES OF DLCU, IBADAN