

# MAC 111

# INTRODUCTION TO MASS COMMUNICATION

---



**NATIONAL OPEN UNIVERSITY OF NIGERIA**

Download more at [Learnclax.com](http://Learnclax.com)



**MAC 111**  
**INTRODUCTION TO MASS COMMUNICATION**

Course Developer/Writer	Joseph Obe Department of Mass Communication Covenant University, Ota, Nigeria
Course Editor	Dr. Victor Ayedun - Aluma Department of Mass Communication University of Lagos
Programme Leader	Christine .I. Ofulue, Ph.D School of Arts and Social Sciences National Open University of Nigeria
Course Coordinator	Chidinma H. Onwubere School of Arts and Social Sciences National Open University of Nigeria



## **NATIONAL OPEN UNIVERSITY OF NIGERIA**

National Open University of Nigeria  
Headquarters  
14/16 Ahmadu Bello Way  
Victoria Island  
Lagos

Abuja Office:  
No.5 Dar-es-Salaam Street  
Off Aminu Kano Crescent  
Wuse II, Abuja  
Nigeria.

e-mail: [centralinfo@nou.edu.ng](mailto:centralinfo@nou.edu.ng)

URL: [www.nou.edu.ng](http://www.nou.edu.ng)

Published by  
National Open University of Nigeria

Printed 2008

ISBN: 978-058-725-X

All Rights Reserved

<b>CONTENTS</b>	<b>PAGE</b>
Introduction .....	1
What You will Learn in this Course.....	1
Course Aims .....	1
Course Objectives .....	2
Working through this Course .....	2
Course Materials .....	2
Study Units .....	3
Textbooks and References .....	4
The Assignment File .....	4
Tutor-Marked Assignment .....	4
Final Examination and Grading .....	5
Course Marking Scheme.....	5
Overview of Course/Presentation Schedule .....	5
How to Get the Most from this Course .....	6
Facilitators/Tutors and Tutorials .....	8
Summary .....	8

## **Introduction**

The code of this course is **MAC 111** while the title is **INTRODUCTION TO MASS COMMUNICATION**. This is a course that ushers you into the discipline of mass communication and gives you a concise and appreciable understanding of the concept of mass communication and its position and role in the society. The course is packaged on a global scale with a view to positioning the students on a pedestal that would make them at par with any entrant into the field of mass communication anywhere in the world. However, some examples used are typically Nigerian in orientation and setting.

Every attempt is made here to balance the print and electronic dimensions of the discipline. Most of the course contents are packaged with the understanding that most of the readers are not professionals in the field of communication but rather beginners who are mostly first year undergraduates and are entirely new in the discipline.

This course guide gives you the required information about this course which includes the course structure, aims and objectives of the course, how you will be assessed and examined and time schedule for each of the assignment and other course related activities.

## **What You will Learn in this Course**

This course is written for students who need to learn basic concept in the discipline of mass communication. You will acquire the basic knowledge about the communication field. The course equally empowers you to join intellectual discourse on the nature, functions and effects of mass communication in the society.

By this course, students will gain the basic understanding of mass communication as a form of human communication and the functions and components of its various media.

## **Course Aims**

The course aims at empowering every beginner in the field of mass communication with the rudimentary knowledge of the complex nature of mass communication, its media and adjunct. Besides, the course aims at exposing the students to the process, nature and forms of mass communication as a subset of human communication.

## **Course Objectives**

At the end of the course, you should be able to:

1. Be fully exposed to the rudiments and basics of mass communication as a subset of human communication.
2. Be acquainted with the contents and characteristics of various types of media of mass communication as well as its adjunct.
3. Have been exposed to various forms, models, elements and nature of mass communication.

## **Working through this Course**

To successfully complete this course, you are strongly advised to read the study units provided as a course material and recommended texts. The recommended texts will give you broader perspective and good understanding of the course. You are also required to do the self assessment exercises which you will find under every unit of this course.

You will be required to submit written assignments listed under the Tutor-Marked Assignment (TMA) section of this course material. The TMA shall constitute your Continuous Assessment for the course. You will be told which of them to be submitted at a particular time.

At the end of the course, you will be required to write a final examination. The course should take about 15 weeks in total to complete.

## **Course Materials**

The major materials you will need for this course are:

1. Course Guide
2. Study Units broken down into twenty (20) of four modules
3. Assignments File
4. Relevant textbooks including the recommended ones
5. You may be required to read newspapers and magazines, and monitor news and programmes on TV and radio

## Study Units

MAC 111 is a three – unit course, packaged in four modules of twenty (20) units. The modules and units are listed below:

### **Module 1    Fundamentals of Communication**

- Unit 1        Understanding the Concept of Communication and Mass Communication
- Unit 2        Nature and Characteristics of Communication
- Unit 3        Elements of the Communication Process
- Unit 4        Models of Communication
- Unit 5        Theories of Mass Communication
- Unit 6        Functions of Mass Communication

### **Module 2    Forms and Context of Communication**

- Unit 1        Verbal Communication
- Unit 2        Non-Verbal Communication
- Unit 3        Intra and Interpersonal Communication
- Unit 4        Group and Public Communication
- Unit 5        Cross Culture/International Communication

### **Module 3    Media of Communication**

- Unit 1        Print Media: Books, Newspaper, Magazine etc
- Unit 2        Book Publishing
- Unit 3        Broadcast Media: Television and Radio
- Unit 4        Narrowcast media: Film and Cinema, Cable Television.
- Unit 5        Online Media: Online Newspapers and Magazines, Internet Radio etc

### **Module 4    Adjunct/Impact of the Mass Media**

- Unit 1        Concept, Development and Functions of Public Relations
- Unit 2        Concept, Development and Functions of Advertising
- Unit 3        Effects of the Mass Media on the Society
- Unit 4        Media Effects Theories

**Textbooks/References**

Baran, S.J. (2002). *Introduction to Mass Communication*. New York: McGraw Hill.

Berko, W. & W. (1989). *Communicating*. New Jersey: Prentice Hall.

Bitner, R. (1989). *Mass Communication: An Introduction*. New Jersey: Prentice Hall.

Defleur, M.L. & Dennis E (1994). *Understanding Mass Communication*. Boston: Houghton Mifflin.

Hybels, S. & Weaver I. (2001). *Communicating Effectively*. Boston: McGraw Hill.

Sambe, J.A. (2005). *Introduction to Mass Communication Practice in Nigeria*. Ibadan: Spectrum Books.

**The Assignment File**

Assessment file will be made available to you. In the file, you will find details of the work you must submit to your tutor for marking. There are two aspects of the assessment of this course: the tutor marked and the written examination. The marks you obtain in these two areas will make up your final marks. The assignment must be submitted to your tutor for formal assessment in accordance with deadlines. The works you submit to your tutor as assignment will count for 30% of your total score.

**Tutor-Marked Assignment**

You will have to submit a specified number of the (TMAs). Every unit in this course has a tutor0marked assignment. You will be assessed on four of them but the best three performances from the (TMAs) will be used for your 30% grading. When you have completed each assignment, send it together with a Tutor Marked Assignment form, to your tutor. Make sure each assignment reaches your tutor on or before the deadline for submissions. If for any reason, you cannot complete your work on time, contact your tutor for a discussion on the possibility of an extension. Extensions will not be granted after the due date unless under exceptional circumstances.



## Final Examination and Grading

The final examination will be a test of three hours. All areas of the course will be examined. Find time to read the units all over before your examination. The final examination will attract 70% of the total course grade. The examination will consist of questions, which reflect the kinds of self assessment exercises and tutor-marked assignment you have previously encountered. And all aspects of the course will be assessed. You should use the time between completing the last unit, and taking the examination to revise the entire course.

## Course Marking Scheme

The following table sets out how the actual course marking is broken down.

Assessment	Marks
Four assignments (the best four of all the assignments submitted for marking).	Four assignments, each marked out of 10%, but highest scoring three selected, thus totalling 30%
Final Examination	70% of overall course score.
<b>Total</b>	<b>100% of course score.</b>

## Course Overview and Presentation Schedule

Unit	Title of work	Weeks Activity	Assignment
<b>Module 1</b>			
1	Understanding the Concept of Mass Communication	Week 1	Assignment 1
2	Nature and Characteristics of Communication	Week 2	Assignment 2
3	Elements of the Communication Process	Week 3	Assignment 3
4	Models of Communication	Week 4	Assignment 4
5	Theories of Mass Communication	Week 5	Assignment 5
6	Functions of Mass Communication	Week 6	Assignment 6
<b>Module 2</b>			
1	Verbal Communication	Week 7	Assignment 7
2	Non-verbal Communication	Week 8	Assignment 8
3	Intra and Interpersonal Communication	Week 9	Assignment 9
4	Group and Public	Week 10	Assignment 10

	Communication		
5	Cross Culture/ International Communication	Week 11	Assignment 11
<b>Module 3</b>			
1	Print Media: Books, Newspaper, Magazine, etc.	Week 12	Assignment 12
2	Broadcast Media: Television & Radio.	Week 13	Assignment 13
3	Narrowcast Media: Film, Cinema, Cable Television.	Week 14	Assignment 14
4	Online Media: Online Newspapers, Magazines Internet Radio etc.	Week 14	Assignment 15
<b>Module 4</b>			
1	Concept. Development and Functions of PR	Week 14	Assignment 16
2	Concept. Development and Functions of Advertising	Week 15	Assignment 17
3	Book Publishing	Week 15	Assignment 18
4	Media Effects	Week 15	Assignment 19
	<b>Revision</b>	<b>1</b>	
	<b>Examination</b>	<b>1</b>	
	<b>Total</b>	<b>17</b>	

### How to Get the Most from this Course

In distance learning, the study units replace the university lecture. This is one of the great advantages of distance learning; you can read and work through specially designed study materials at your own pace, and at a time and place that suits you best. Think of it as reading the lecture instead of listening to the lecturer. In the same way a lecturer might give you some reading to do, the study units tell you where to read, and which are your text materials or set books. You are provided with exercises to do at appropriate points, just as a lecturer might give you an in-class exercise. Each of the study units follows a common format. The first item is an introduction to the subject matter of the unit, and how a particular unit is integrated with the other units and the course as a whole. Next to this is a set of learning objectives. These objectives let you know what you should be able to do by the time you have completed the unit. These learning objectives are meant to guide your study. The moment a unit is finished, you must go back and check whether you have achieved the objectives. If this is made a habit, then you will significantly improve your chances of passing the course. The main body of the unit guides you through the required reading from other sources. This will usually be either from your set books or from a

Reading section. The following is a practical strategy for working through the course. If you run into any trouble, telephone your tutor. Remember that your tutor's job is to help you. When you need assistance, do not hesitate to call and ask your tutor to provide it.

1. Read this Course Guide thoroughly, it is your first assignment.
2. Organize a Study Schedule. Design a 'Course Overview' to guide you through the Course. Note the time you are expected to spend on each unit and how the Assignments relate to the units. Whatever method you choose to use, you should decide on and write in your own dates and schedule of work for each unit.
3. Once you have created your own study schedule, do everything to stay faithful to it. The major reason students fail is that they get behind with their course work. If you get into difficulties with your schedule, please, let your tutor know before it is too late to help.
4. Turn to Unit I, and read the introduction and the objectives for the unit.

## 5.

- Assemble the study materials. You will need your set books in the unit you are studying at any point in time. As you work through the unit, you will know what sources to consult for further information.
6. Keep in touch with your study centre. Up-to-date course information will be continuously available there.
7. Keep in mind that you will learn a lot by doing the assignment carefully and well before the relevant due dates. The assignments have been designed to help you meet the objectives of the course and, therefore, will help you pass the examination. Submit all assignments not later than the due date.
8. Review the objectives for each study unit to confirm that you have achieved them. If you feel unsure about any of the objectives, review the study materials or consult your tutor.
9. When you are confident that you have achieved a unit's objectives, you can start on the next unit. Proceed unit by unit through the course and try to pace your study so that you keep yourself on schedule.

10. When you have submitted an assignment to your tutor for marking, do not wait for its return before starting on the next unit. Keep to your schedule. When the assignment is returned, pay particular attention to your tutor's comments, both on the tutor-marked assignment form and also the written comments on the ordinary assignments.
11. After completing the last unit, review the course and prepare yourself for the final examination. Check that you have achieved the unit objectives (listed at the beginning of each unit) and the course objectives (listed in the Course Guide).

### **Facilitators/Tutors and Tutorials**

Information relating to the tutorials will be provided at the appropriate time. Your tutor will mark and comment on your assignments, keep a close watch on your progress and on any difficulties you might encounter and provide assistance to you during the course. You must take your tutor-marked assignments to the study centre well before the due date (at least two working days are required). They will be marked by your tutor and returned to you as soon as possible.

Do not hesitate to contact your tutor if you need help. Contact your tutor if:

- you do not understand any part of the study units or the assigned readings
- you have difficulty with the exercises
- you have a question or problem with an assignment or with your tutor's comments on an assignment or with the grading of an assignment.

You should try your best to attend the tutorials. This is the only chance to have face-to-face contact with your tutor and ask questions which are answered instantly. You can raise any problem encountered in the course of your study. To gain the maximum benefit from course tutorials, prepare a question list before attending them. You will learn a lot from participating in discussion actively.

### **Summary**

This course guide has provided an overview of what to expect in the course of this study. It is hoped that you will find it very useful. Wishing you the very best in the course.



Course Code	MAC 111
Course Title	Introduction to Mass Communication
Course Developer/Writer	Joseph Obe Department of Mass Communication Covenant University, Ota, Nigeria
Course Editor	Dr. Victor Ayedun - Aluma Department of Mass Communication University of Lagos
Programme Leader	Christine .I. Ofulue, Ph.D National Open University of Nigeria
Course Coordinator	Chidinma H. Onwubere National Open University of Nigeria



**NATIONAL OPEN UNIVERSITY OF NIGERIA**

National Open University of Nigeria  
Headquarters  
14/16 Ahmadu Bello Way  
Victoria Island  
Lagos

Abuja Office:  
No.5 Dar-es-Salaam Street  
Off Aminu Kano Crescent  
Wuse II, Abuja  
Nigeria.

e-mail: [centralinfo@nou.edu.ng](mailto:centralinfo@nou.edu.ng)  
URL: [www.nou.edu.ng](http://www.nou.edu.ng)

Published by  
National Open University of Nigeria

Printed 2008

ISBN: 978-058-725-X

All Rights Reserved

<b>CONTENTS</b>	<b>PAGE</b>
<b>Module 1    Fundamentals of communication .....</b>	<b>1</b>
Unit 1    Understanding the concept of Communication and Mass Communication .....	1
Unit 2    Nature and Characteristics of Communication .....	11
Unit 3    Elements of the Communication Process .....	20
Unit 4    Models of Communication .....	27
Unit 5    Theories of Mass Communication .....	35
Unit 6    Functions of Mass Communication .....	60
<b>Module 2    Forms and Context of Communication .....</b>	<b>73</b>
Unit 1    Verbal Communication .....	73
Unit 2    Non-Verbal Communication .....	80
Unit 3    Intra and Interpersonal Communication .....	89
Unit 4    Group and Public Communication .....	102
Unit 5    Cross Culture/International Communication.....	109
<b>Module 3    Media of Communication.....</b>	<b>115</b>
Unit 1    Print Media: Books, Newspaper, Magazine .....	115
Unit 2    Book Publishing .....	127
Unit 3    Broadcast Media: Television and Radio .....	139
Unit 4    Narrowcast Media: Film and Cinema, Cable Television.....	155
Unit 5    Online Media: Online Newspapers and Magazines, Internet Radio.....	167
<b>Module 4    Adjunct/Impact of the Mass Media .....</b>	<b>178</b>
Unit 1    Concept, Development and Functions of Public Relations.....	178
Unit 2    Concept, Development and Functions of Advertising .....	193
Unit 3    Effects of the Mass Media on the Society.....	202
Unit 4    Media Effects Theories.....	207





## **MODULE 1      FUNDAMENTALS OF COMMUNICATION**

Unit 1	Understanding the Concept of Communication and Mass Communication
Unit 2	Nature and Characteristics of Communication
Unit 3	Elements of the Communication Process
Unit 4	Models of Communication
Unit 5	Theories of Mass Communication
Unit 6	Functions of Mass Communication

### **UNIT 1      UNDERSTANDING THE CONCEPT OF COMMUNICATION AND MASS COMMUNICATION**

#### **CONTENTS**

1.0	Introduction
2.0	Objectives
3.0	Main Content
3.1	What is Communication?
3.1.1	Understanding Communication
3.2	Functions of Communication
3.2.1	Functional Meaning of Communication
3.3	What is Mass Communication?
3.4	Features of Mass Communication
3.5	Between Mass Communication and Human Communication
4.0	Conclusion
5.0	Summary
6.0	Tutor-Marked Assignment
7.0	References/Further Readings

#### **1.0      INTRODUCTION**

This introductory unit examines five items that address issues surrounding the understanding of the concept of communication. They are:

1. Various Definitions of Communication
2. Various Definitions of Mass Communication
3. Functions of Communication
4. Features of Mass Communication
5. Difference between Mass Communication and Human Communication

## 2.0 OBJECTIVES

At the end of this unit, you should be able to:

- define Communication, either in your own words or by other scholars who are grounded in the field
- define Mass Communication
- identify the main features of communication
- explain the basic functions of mass communication
- distinguish mass communication from human communication.

## 3.0 MAIN CONTENT

### 3.1 What is Communication?

Communication is a common phenomenon that cuts across the daily activities of human being. As food and water are very important to man's survival so is communication. It is always a unique feature that differentiates the living from the dead. Obilade (1989) defines communication as a process that involves the transmission of message from a sender to the receiver.

A group of Nigerian Communication Scholars namely Babatunde Folarin, Dayo Soola, Isaac Ode, Frank Ugboajah variously define communication as follows:

- Any means by which a thought is transferred from one person to another (Folarin 2003).
- The process by which any person or a group shares and impacts information with/to another person(or group) so that both people(or groups) clearly understand one another (Soola 2000).
- Not just giving of information, it is the giving of understandable information and receiving and therefore, the transferring of a message to another party so that it can be understood and acted upon (Ode 1999).
- The process which involves all acts of transmitting messages to channels which link people to the languages and symbolic codes which are used to transmit such messages. It is also the means by which such messages are received and stored. It includes the rules, customs and conventions which define and regulate human relationships and events (Ugboajah 2001).

In its simplest form, however, Communication is the transmission of a message from a source to a receiver...or the process of creating shared meaning (Baran 20004:4)

### 3.1.1 Understanding Communication

It has been shown that there exists various definitions for communication, as there are different disciplines. While some definitions are human centred, others are not. For example, communication system may incorporate computers, as well as less sophisticated reproducing devices such as photocopiers. A photocopier may see communication as meaning different thing from the way a marketer perceives it. Similarly, a gospel preacher may think communication is something, which is of course different from what a journalist thinks it is.

Therefore, there is no single definition of communication agreed upon by scholars. Psychologists, sociologists, medical practitioners, philosophers and communication specialists, all define communication based on their orientations and perspectives.

Psychologists define communication as "the process by which an individual (the communicator) transmits stimuli (usually verbal symbols) to modify the behaviour of the other individuals (communicates)." This definition describes what many extension workers and change agents hope to achieve. Sociologists see communications "as the mechanism through which human relations exist and develop." Some people define communication rather narrowly, saying "communication is the process whereby one person tells another something through the written or spoken word." This definition, from a book written by a journalist, seems reasonable for those in that field. So, there are definitions of communication as there are various disciplines.

Communication is from a Latin word- *COMMUNIS*, which means *common* or *shared understanding*. Communication therefore is a purposeful effort to establish *commonness* between a source and receiver (Schramn 1965). Whatever is being shared could be associated with knowledge, experience, thought, ideas, suggestion, opinions, feelings etc. We will define communication here as the process of exchanging or sharing information, ideas and feeling between the sender and the receiver.

Communication is very central to all human activities; this is because everything we do and do not, communicate. Man's interaction with other human beings is a result of communication. Communication is the key around which human life revolves.

Communication is also innate – every man is born with the ability, from childhood, we learn to communicate by crying, smiling, kicking etc.

Communication is dynamic, ongoing and ever changing. Communication is made up of activities of interrelated elements which continue to function in the communication process. The fact is that the word communication is encompassing, ambiguous and pervasive. These three words capture the universal nature of communication and make everyone think they know something about communication.

### **SELF ASSESSMENT EXERCISE 1**

- A. All living animals communicate. Do you agree? Justify your position.
- B. What makes human communication different from that of other animals?

## **3.2 Functions of Communication**

Communication performs diverse kinds of functions. We will look at the following functions:

### **1. Social Interaction**

Human interaction is possible because we can communicate. We relate with friends, parents, colleagues, etc because we share codes that make us understand each other. Without communication this will not be possible.

### **2. Business and Trade**

Communication provides opportunity to transact business and engage in trade. We are able to make known what we are offering for sales and what we want to buy. We also negotiate the prices, mode of delivery etc. through communication

### **3. Exchange of Ideas and Spread of Knowledge**

We express freely our ideas, opinions and feelings on issues affecting us. We also share knowledge as we engage in discussion and write books. In classroom situation, a teacher is able to impart knowledge into students through communication.

#### **4. Social-Political Development**

Development is made possible through communication. Communication helps to mobilise people to work together for their social and political development.

#### **5. Social-Cultural Integration**

Communication enables exchange of culture and values. Through music, interaction in communities, we are able to learn one another's cultures and blend for harmonious co-habitation.

### **3.2.1 Functional Meaning of Communication**

Communication could be defined based on its perceived functions. Severin and Tankard (1980) highlight some of the basic differences in the way communication has been perceived. They grouped these into three major areas:

- i. Definitions that stress sharing
- ii. Definitions that stress intentional influence and
- iii. Definitions that include any kind of influence or response (with or without intent)

#### **Definitions that Stress Sharing**

A number of scholars defined communication in relation to its etymology hence, communication is seen as a concept of sharing or making common. One of such definitions is Cheryl et al (1982) which says that it is "the process of sharing thoughts, ideas and feelings with each other in commonly understandable ways". Similarly, Bennett (1976) refers to communication as the process of sharing meaning through the use of symbols.

#### **Definitions that Stress Intentional Influence**

Another school of thought suggests that communication is mainly dependent on persuasion. Horne et al (1965) lend credence to this when they stated that "communication is the process through which a person motivates and influences others to control and modifying their behaviours". Keegan (1980) refers to communication as "all forms of information transfer and persuasion concerning a product".

**Definition that include any kind of influence or response (with or without intent)**

These definitions could also be referred to as “all inclusive” definitions. As Lederman (1977) puts it: Communication is a word used to refer to multitude of activities in which people engage such as talking, touching, writing, looking etc”. Luthans (1985) opines that “communication means the flow of material information, perception and understanding between various parts and members of an organization”.

A second look at the aforementioned functional definitions would show that each of them serves some useful purposes despite their inherent weaknesses. For instance, the belief that the essence of communication is based on persuasion may be true in some cases but definitely not in every situation. When a piece of public service announcement is made in the broadcast media or print media, the goal may not necessarily be to persuade the public into believing the message but simply to inform them. However, this does not mean that, we don't have occasions when communication is designed mainly to persuade the listeners or reading public. This is true of advertisement and public relations activities.

From the fore-going, we can conclude here that, communication can serve a number of different functions like information, education, entertainment, persuasion, and so on.

**SELF ASSESSMENT EXERCISE 2**

Give your own definition of communication based on your perceived functions.

**3.3 What is Mass Communication?**

Mass Communication is a means of disseminating information or message to large, anonymous, and scattered heterogeneous masses of receivers who may be far removed from the message sources through the use of sophisticated equipment. In other words, communication is the sending of message through a mass medium to a large number of people.

Mass Communication represents the creation and sending of a homogeneous message to a large heterogeneous audience through the media. Mass communication studies the uses and effects of the media by many as opposed to the study of human interaction as in other communication contexts.

Stanley Baran defines Mass Communication as the process of creating shared meaning between the mass media and their audience. Also, John Bittner defines Mass Communication as messages communicated through a mass medium to a large number of people.

One needs to underscore the underlying fact that what is common in every definition of mass communication anywhere in the world is that it is communicated through a mass medium. In other words, for any message to be regarded as being mass communicated, it must be disseminated through a mass medium like Radio, Television, Newspaper and Magazine.

Mass Communication can also be defined as a device by which a group of people working together transmits information to a large heterogeneous and anonymous audience simultaneously. It is a process by which information originates from the source to the receiver, having been thoroughly filtered and transmitted through a channel ( Sambe 2005:29).

### **SELF ASSESSMENT EXERCISE 3**

What makes Mass Communication to be Mass Communication?

#### **3.4 Features of Mass Communication**

Mass Communication is distinguished from other kinds of communication by a number of features or characteristics. They are:

1. Mass Medium
2. Presence of Gatekeepers
3. Delayed Feedback
4. Limited Sensory Channels
5. Impersonal Vs Personal Communication

#### **Mass Medium**

For a medium to be regarded as mass in communication it must have acquired fifty million adopters (Kaye & Medoff 2005). Radio, Television, internet etc are examples of media which are regarded as mass media because they can reach out to no fewer than fifty million audience at a time. In mass communication, messages reach far beyond the immediate proximity of the sender and could even get to the uttermost part of the world.

## Presence of Gatekeepers

In mass communication, sent messages do not reach the audience in raw form. Messages are usually 'treated'. The implication of this is that there is usually no guarantee that what the message receivers get is exactly the message sent by the source.

In mass media organizations, the gatekeepers are usually the reporters, sub-editors, editors, producers, writers, etc. The concept of gatekeeper was first coined by Kurt Lewin who describes gatekeepers as individuals or groups of persons who govern the travels of news items in the communication channels.

Gatekeepers could also be defined as any person or formally organized group directly involved in relaying or transferring information from one individual to another through a mass medium. A gatekeeper can be a film producer who cuts a scene from the original script, a network censor who deletes a scene from a prime – time show because it is perceived as being too sexually explicit, a director who determines what segment of film to use in a documentary, a newspaper executive who determines the topic for an editorial, or any other individual in the processing or control of messages disseminated through mass media (Bittner 1989:12).

In actual sense, a gatekeeper does three major functions:

1. **Limiting** the information through editing before dissemination.
2. **Expanding** the amount of information by injecting additional views or angles.
3. **Reorganizing or Reinterpreting** the information gathered before disseminating it.

## Delayed Feedback

Unlike in interpersonal communication where reply/feedback is made almost instantly, the feedback in mass communication is always delayed, say for a day, week or month. Burgoon et al 1978 cited in Folarin 1994 says "Feedback is often limited, delayed and indirect". Mass Communicators are usually subject to additional feedback in form of criticism in other media, such as a television critic writing a column in a newspaper (Baran 2004:7). In other words, feedback in mass communication is not instant. It is mostly through letters to the editor or telephone calls or personal calls on the media

Stanley Baran coined the term 'delayed inferential feedback' when he said that television executives do not usually wait for feedbacks on



what they must do not to improve programming but only infer using the rating measured by the number of viewers.

### **Limited Sensory Channels**

This feature has to do with the fact that mass medium limits the number of sensory channels upon which audience can draw. In other words, mass communication only enables one to use his or her sense of sight and hearing since one can only see the visual picture and hear the voice of the speaker on the broadcast station. This is unlike in a face- to- face communication where the audience can shake hands or hug the politicians and as such, have no limitation to the sensory channels.

### **Impersonal and Personal Communication**

Unlike in face – to – face communication where communication is personal, participants in mass communication are usually strangers and, hence messages are more impersonal.

### **SELF ASSESSMENT EXERCISE 4**

What are the distinguishing attributes of Mass Communication?

### **3.5 Between Mass Communication and Human Communication**

Simply put, Human Communication is a dynamic process of sharing information between individuals. It encompasses all kinds of communication that involves man. It must be pointed out that mass communication is part of human communication. It is one of the three major parts of human communication. The other parts being interpersonal and intrapersonal communication.

The easiest way to distinguish mass communication from other parts of human communication is to highlights the unique features inherent in mass communication, which had been discussed earlier in this unit.

### **SELF ASSESSMENT EXERCISE 5**

- A. Mass Communication is a subset of human Communication. Discuss.
- B. Draw out the dichotomy between Mass Communication and Human Communication.

## **4.0 CONCLUSION**

Communication traverses every facet of human life. Without communication nothing can be done. In other words, communication holds the foundation of every human society. It is the process of exchanging, transmitting, transferring, expressing or importing ideas, sentiments, attitudes, feelings, meanings, information or opinion between individuals, groups or organizations. (Sambe 2005:2).

## **5.0 SUMMARY**

In this unit, we have been able to establish that communication is an essential part of human life and that human communication and mass communication are integral part of communication, hence we cannot study any of them in isolation of the concept of communication. We also attempted an overview of the concept of communication, mass communication and human communication, as well as the similarities and differences between them. The unit also highlighted the features that distinguish mass communication from other forms of communication.

## **6.0 TUTOR-MARKED ASSIGNMENT**

Write a three – page essay on why you chose to study Mass Communication as against Human Communication in the University. If given the opportunity, would you prefer to study human communication and not mass communication or you still prefer to study mass communication?

## **7.0 REFERENCES/FURTHER READINGS**

Baran, S.J. (2002). *Introduction to Mass Communication*. New York: McGraw Hill.

Bitner, R. (1989). *Mass Communication: An Introduction*. New Jersey: Prentice Hall.

Sambe J.A. *Introduction to Mass Communication Practice in Nigeria*. Ibadan: Spectrum Books Limited.

## **UNIT 2 NATURE AND CHARACTERISTICS OF COMMUNICATION**

### **CONTENTS**

- 1.0 Introduction
- 2.0 Objectives
- 3.0 Main Content
  - 3.1 Nature of Communication
  - 3.2 Characteristics of Communication
  - 3.3 Attributes of Communication
- 4.0 Conclusion
- 5.0 Summary
- 6.0 Tutor-Marked Assignment
- 7.0 References/Further Readings

### **1.0 INTRODUCTION**

This unit assumes that students have acquired a considerable knowledge of the concept of communication, as dealt with in unit 1. This unit delves more into communication under two main subheadings:

1. Nature of mass communication
2. Characteristics of mass communication

### **2.0 OBJECTIVES**

At the end of this unit, you should be able to:

- discuss the inherent nature of communication
- specifically highlight and discuss in great details the characteristics of communication.

### **3.0 MAIN CONTENT**

#### **3.1 Nature of Communication**

Having established the basic concept of communication in unit 1 as the process of sharing meanings or transmitting meanings to individuals, one needs to reiterate here that for human beings, the process of communication is both vital and fundamental. It is vital and fundamental so far as all human societies – primitive to modern – are founded on man's ability to transmit his intentions, desires, feelings, knowledge and experiences from person to person. It is vital as the ability to communicate with others enhances an individual's chances of survival

while inability to do so is generally regarded as a serious form of personal pathology (Sambe 2005:28).

Mass communication got its origin from the fundamental process of human communication that enables man-to-man discussion and communicative interactions. This was done chiefly through verbal and written cues. With the emerging trends in electronic engineering, people are increasingly aware of how to communicate to many people at the same time – ‘one to many’. This ‘one-to-many’ concept is the peculiar nature of mass communication. A man in the broadcast studio somewhere in Lagos, Nigeria can communicate to billions of people across the globe simultaneously. The President of the Federal Republic of Nigeria can sit down in Aso Rock and speak to 140 million Nigerians at the same time. This is mass communication in practice. Broadcast journalists cast news to an audience of millions at the same time; newspaper editors write on issues of public importance to be read the next day by all concerned. These are all mass communication in practice. This unique way of communicating to countless number of people at the same time is a unique nature of mass communication. It is very peculiar because no other form of communication has this attribute.

This brings us to three distinguishing features of mass communication.

They are:

- a. nature of audience
- b. the communication experience
- c. the communicator

### **Nature of Audience**

By nature, mass communication audience has four peculiar features.

They are:

- a) large
- b) heterogeneous
- c) anonymous
- d) simultaneous

### **Large**

The large nature of the audience of mass communication makes it very difficult to address mass communication messages to specific audience or group of people. This presupposes the fact that messages that undergo

mass communication process must be directed to very many people, like the ones sent through mass media of radio, TV, newspapers etc.

It must be pointed out that messages meant for very few people or specific individuals are not regarded as mass communication. For instance, a love letter sent from a boy to his lover girl; a GSM conversation between two or more people (as in conference call) or telegrams do not belong to the mass communication family. This is because such messages could be regarded as either one-to-one or one-to-few as against mass communication which is one-to-many.

### **Heterogeneous**

By heterogeneous, we mean mass communication messages cannot be segregated. It cannot be directed towards certain people without others hearing it. Every human being, irrespective of age, creed, sex, wealth and affluence get the messages at the same time. Biblically speaking, mass communication message is not a respecter of any man. It does not have regard for positions, and class. It is for all.

### **Anonymity**

Messages sent in mass communication are not to be received by a named receiver. It is addressed to whom it may concern. In other words, he who receives the messages is not known to the sender. It is assumed that messages in mass communication are sent to nobody, everybody and somebody.

### **Simultaneity**

This holds that messages of mass communication are at the disposal of the audience at the **same time** or **simultaneously**, or **instantly**. The word 'disposal' is used because, even though the message is available to one, the audience might decide not to expose himself to the message almost immediately, the audience might delay his exposure to such messages for different reasons. This message is often associated with the print media of mass communication like newspapers, magazines and books. A reader might decide not to read the pages of a book almost immediately. The same way someone who got the delivery of fresh news on a daily newspaper early in the morning might delay reading such news till bed time.

Hence, the simultaneity in mass communication audience is mostly applicable to messages sent via the broadcast media, but the fact is that everybody is disposed to such message instantaneously.

### **The Communication Experience**

The idea here is that mass communication messages are rapid, public and transient. It is public in that the content is for public good; it is not directed to only selected few but the general public and that the messages are sent for the consumption of every member of the public.

Mass communication messages by nature are rapid because the messages get to audience almost immediately. With the aid of new communication technologies, it takes seconds to pass across the globe.

The messages are said to be transient because of its fast 'moving' nature. The messages are meant to be consumed almost immediately. The newscaster does not wait for anybody to be ready before he casts the news, nor does he need to wait until the listener is ready before continuing his job. In the broadcast media of mass communication, listeners have the opportunity to hear the messages once.

### **Nature of Communicator**

This talks about the particular medium through which the message will pass through. The media is managed by media organisations and run by experts. The various media of mass communication have features peculiar to each and every one of them as they operate within a complex organisation that may require great expense.

### **SELF ASSESSMENT EXERCISE 1**

Would you regard a tutorial facilitator in a study centre of National Open University of Nigeria who uses microphone to communicate to a fairly small number of students as a mass communicator? Give convincing reasons for your position.

### **3.2 Characteristics of Mass Communication**

Although some scholars tend to mix characteristics of mass communication with features of mass communication as discussed in unit 1, but painstaking attempts have been made here to bring out specific characteristics of mass communication. They include:

- a) Impersonality
- b) Portability and mobility
- c) Transportability/proximity
- d) Fidelity
- e) Permanency
- f) Cost
- g) Universality

## **Impersonality**

Messages of mass communication have remained impersonal since there is no “personal” touch or warmth of a medium. The impersonality of mass communication is informed by the need to reach large, diverse and scattered audiences almost at the same time.

## **Portability and Mobility**

These two terms are mostly used interchangeably to describe the character of mass communication. Portability has to do with the fact that messages of mass communication are handy and that the medium through which the messages are passing could be carried from one place to another.

Mobility refers to the ease with which a medium’s paraphernalia (facilities) of production can be moved from one place to another. One way of distinguishing between the two terms is to note that portability concerns the receiver and the geographical location of message consumption while mobility relates to the source and place of production.

It needs to be pointed out, however, that while miniaturization of radio has made it portable and much easier to be carried around, mobility has been greatly hampered by bureaucratic nature of media management as well as by media laws of access in the country.

## **Transportability/Proximity**

By proximity, we mean the power of the medium of mass communication to carry the recipient over to the scene of an event. For instance, people in a place like Ota in Nigeria could watch live a football match in far away Adelaide, Australia. In other words, the medium of mass communication is able to “take” a recipient to the scene of an event without the recipient stepping out of his bedroom.

## **Fidelity**

One good advantage of today’s electronics especially, TV is hi-fidelity. Most times, the logo Hi-fi is printed on electronic products to show that the electronics device is capable of giving the audience a near the original form of the figure that is being transmitted

Fidelity refers to the exactitude with which a medium reproduces the original physical dimensions of images of the messages being sent across. The original dimension includes:

- a) Verbal symbols
- b) Picture symbols
- c) Colour
- d) Sound and
- e) Motion.

In actual sense, only television and film can reproduce all the five dimensions, while radio can only produce speech and sound exactly. Print media can reproduce pictures, symbols and colors.

With the emergency of flat screen television and home theatre, fidelity of the medium is becoming higher by day. It must be pointed out that aside television; internet communication can reproduce all the five dimensions with higher fidelity than that of Television.

### **Cost**

Every medium of mass communication requires one to pay before sending messages through it. A full colour page advert in an average Nigeria newspaper costs no less than N150, 000 while a 60 second slot in NTA costs one an average of N100, 000. Depending on the medium being used, the cost of mass communication messages is on the relatively high side. This is solely because of the reach of the medium.

### **Universality**

This refers to the extensiveness or commonness of a medium. A person does not need to be literate in a particular language before he listens to a radio programme or a watch television programme in that native language.

### **Permanency**

This refers to the period for which a medium can hold its message thereby making the message reviewable. Unlike in the electronic media which are transitory in nature, a reader of a book, newspapers and magazines can read and re-read what is there, because what is in the print media products may be there for a long term if not permanent.

Sambe (2005:35) highlighted the elements of the characteristics of media of mass communication as follows:

- a) Emphasis
- b) Fidelity
- c) Circulation
- d) Reproduction
- e) Feedback
- f) Support



## **SELF ASSESSMENT EXERCISE 2**

Most television users around the world, especially in Nigeria now prefer to use flat screen television and home theatre electronics gadgets in their home. What specific characteristic of the media of mass communication is responsible for such growing interest?

### **3.3 Attributes of Communication**

As contained in Folarin (2002), Micheal Burgoon and Micheal Ruffner pointed out five attributes of communication; added to that are other six by Bert Bradly. They are briefly presented below:

#### **1. Transactional**

Communication is transactional because both the source and the receiver are having an impact on one other.

#### **2. Affective**

Our emotional responses affect the way we communicate with others and the way others communicate with us. This makes communication affective.

#### **3. Personal**

This means that the meanings attached to communication exist in the participants and not in the non-verbal symbols we employ in communicating. But each participant is able to understand the other because of the codes of verbal and non-verbal symbols that they share.

#### **4. Consummatory**

This means that communication provides satisfaction to the communicator.

#### **5. Instrumental**

Communication can be used as a tool to control our environment and to affect or influence other people.

#### **6. Dynamic**

Communication is not static. It involves changes and effects as the elements interact.

**7. Continuous**

There is no beginning and no end to communication in a person's life.

**8. Complex**

It occurs at many levels and reflects many influences.

**9. Irreversible**

Once a message is sent, it cannot be withdrawn. Communication process cannot be turned back.

**10. Non-sequential**

The elements in the communication process are not rigidly patterned, as in a linear or circular manner.

**11. Unrepeatable**

A given communication act cannot be recreated.

**SELF ASSESSMENT EXERCISE 3**

One of the attributes of communication is that given communication act cannot be recreated. How would you justify this statement using both the radio and newspaper as two different instances?

**4.0 CONCLUSION**

By virtue of its nature, communication takes place in three ways, namely Mass (one-to-many), interpersonal (one-to-one), and computing (many-to-one) with a fourth communication mode, many-to-many, emerging. On the Internet, everyone can be a producer or a receiver, individuals can receive and send personal or mass messages, and information can be provided by many and accessed by many as a mass audience or stored for individuals to select and retrieve.

**5.0 SUMMARY**

In this unit, we have been able to establish that communication has peculiar nature and characteristics. The characteristics include Impersonality, Portability and Mobility, Transportability/Proximity, Fidelity, Permanency, Cost and Universality. A team of scholars equally combined about eleven items to be attributes of communication, which include Transactional, Affective, Personal, Consummatory,

Instrumental, Dynamic, Continuous, Complex, Irreversible, Non-sequential and Unrepeatable

## **6.0 TUTOR–MARKED ASSIGNMENT**

Take a cursory look at the nature, characteristics and attributes of communication discussed in this unit. Do they all apply to all forms of communication? If no, group them as they apply to forms of communication. For instance, ‘large nature of audience’ as an attribute belongs to mass communication and not inter personal communication.

## **7.0 REFERENCES/FURTHER READINGS**

Baran, S.J. (2002). *Introduction to Mass Communication*. New York: McGraw Hill.

Bitner, R. (1989). *Mass Communication: An Introduction*. New Jersey: Prentice Hall.

Sambe J.A. (2005). *Introduction to Mass Communication Practice in Nigeria*. Ibadan: Spectrum Books Limited

Uyo, A. O. (1989). *Mass Communication Media: Classification and Characteristics*. New York: Civilities, 1987.

## **UNIT 3    ELEMENTS    OF    THE    COMMUNICATION PROCESS**

### **CONTENTS**

- 1.0 Introduction
- 2.0 Objectives
- 3.0 Main Content
  - 3.1 Process of Communication
  - 3.2 Elements of the Communication Process
  - 3.3 Analysis of the Communication Process
- 4.0 Conclusion
- 5.0 Summary
- 6.0 Tutor-Marked assignment
- 7.0 References/Further Readings

### **1.0 INTRODUCTION**

This unit takes a vivid look at the process of communication as well as the elements involved in the communication process. It equally takes a look at the analysis of the communication process.

### **2.0 OBJECTIVES**

At the end of this unit, you should be able to:

- identify and explain what it takes for good communication to take place
- Identify and explain elements of the communication process
- determine various factors that influence the elements of the communication process.

### **3.0 MAIN CONTENT**

#### **3.1 Process of Communication**

Communication as a process is dynamic, recursive, on-going, continuous and cyclical. There is no recognisable beginning and end, neither is there a rigid sequence of interaction. But we may try to identify how the process begins.

- **Stimulation**

This is the point at which the source sees the need to communicate. He receives stimulus that triggers him to communicate.

- **Encoding**

The source processes the message he want to communicate into a form that will be understandable to the receivers. This may be a feeling, opinion, experiment etc.

- **Transmission**

The message is passed across to the receiver through a chosen medium or channel.

- **Reception**

The receiver gets the message that is sent from the source

- **Decoding**

The message is processed, understood and interpreted by the receiver.

- **Response**

This is the reaction of the receiver to the message received, in form of feedback

The process of communication can be well understood by the models that have been designed to explain the process. This is explained later under models of communication.

James, Ode and Soola (1990:4 cited in Sambe 2005:3) state that the communication process involves an action, reaction and interaction. By **Action**, it refers to the initiative taken by a sender or source to share information, observation or opinion with others. This could be done through writing, speaking, drawing or gesturing.

By **Reaction**, it means a response to the action taken by the sender. The kind of response determines whether or not the receiver is willing to be a party to the communication encounter, and sets the tone or atmosphere for it. Reaction in a communication process may come by way of reply, rejoinder, answer, acknowledgement, retort or defence.

By **Interaction**, it means that communication is the spontaneous reciprocity of messages between a sender and a receiver. It is the stage of exchange of messages between two or more persons sharing common experiences, codes or symbols. Interaction as a process of communication creates an overlap of field of experience between a source and a recipient. With this, they are tuned to each other physically,

mentally or psychologically, and provide a basis to carry on the encounter (interaction) meaningfully and successfully.

### **SELF ASSESSMENT EXERCISE 1**

Communication is not a singular deed, but a set of co-ordinated, interlinked deeds. Explain.

## **3.2 Elements of the Communication Process**

We can identify about seven elements that are involved in the communication process. They are:

### **1. Stimulus**

This is the impulse that triggers off the communication exchange. It takes place at the ideation stage of communication. We can also call it the reason one has for communicating, which may be to inform, educate, entertain etc.

### **2. Source**

This is the person who begins the communication process. He is the one triggered by the stimulus and from him begins the communication activity. He could be referred to as the initiator, encoder or sender. He is the initiator because he begins the communication process. As the encoder, he packages the message in a way that it can be communicated and as the sender when he passes across the message by himself.

### **3. Message**

This could be the idea, feelings, information, thought, opinion, knowledge or experience etc. that the source/sender wants to share.

### **4. Medium/Channel**

Medium and channel are generally used interchangeably. But here, a distinction is made between the two. Medium could be regarded as the form adopted by the sender of the message to get it to the receiver. It could be oral or written form. The channel then is the pathway, route or conduit through which the message travels between the source and the receiver e.g. the channel of radio, television, newspaper, telephone etc. Channel provides a link that enables the source and the receiver to communicate. It may also be seen in terms of the five physical senses-sight, sound, touch, taste and smell-through which messages can be sent, received, understood, interpreted and acted upon.

## 5. Receiver

This is the person to whom the message is sent. He is the target audience or the recipient of the message. All the source/sender's effort to communicate is to inform or affect the attitude of the receiver. That is why communication must be receiver-centred.

## 6. Feedback

This is the response or reaction of the receiver to the message sent. Communication is incomplete without feedback. It confirms that the message is well received and understood. Feedback guides the source in communication process and helps him to know when to alter or modify his message if not properly received. A feedback is positive when it shows that the message has been well received and understood and it could be negative when it shows that the intended effect has not been achieved

## 7. Noise

Noise is interference that keeps a message from being understood or accurately interpreted. It is a potent barrier to effective communication. Noise may be in different forms:

- I. **Physical Noise:** This comes from the environment and keeps the message from being heard or understood. It may be from loud conversations, side-talks at meetings, vehicular sounds, sounds from workmen's tools etc.
- II. **Psychological Noise:** This comes from within as a result of poor mental attitude, depression, emotional stress or disability.
- III. **Physiological Noise:** Results from interference from the body in form of body discomforts, feeling of hunger, tiredness etc
- IV. **Linguistic Noise:** This is from the source's inability to use the language of communication accurately and appropriately. It may be a grammatical noise manifested in form of defects in the use of rules of grammar of a language, and faulty sentence structure. It may be semantic as in the wrong use of words or use of unfamiliar words, misspelling, etc. And it could also be phonological manifested in incorrect pronunciation.

## SELF ASSESSMENT EXERCISE 2

When is a communication message said to be completed? Why is feedback in Mass Communication said to be delayed?

### 3.3 Analysis of the Communication Process

When we attempt to find the meaning of the basic constituents of a communication situation, it becomes clear that *process* is the key to how humans communicate. For example, you are in a large assembly hall awaiting the arrival of a featured speaker. You turn to the person next to you and begin to converse. In this situation you have immediately established a *dyadic* ("two-way") communication relationship, with the source and receiver interdependent. One defines the other. You may be the immediate source whereas the other person serves as receiver or vice versa. An interpersonal communication situation is set up between the two of you.

Suppose you want to establish communication contact with your neighbour. You feel the need; the message is transmitted by your central nervous system to your speech mechanism. At that point the part of the brain responsible for speech produces a message that expresses your purpose. You say, "Hello, my name is Sam." Once this message has been transmitted through time and space (the only way, so far, that we can adequately communicate with each other), the receiver's decoder goes to work. In a sense, this may be viewed as the reverse operation by the speech mechanism in the brain. Thus, if there is no interference at the hearing level and none at the decoding level, the response should be indicative that the expression "Hello, my name is Sam" had a social-contact meaning for the receiver. A typical response might be "And I'm Susan." The miracle of communication has occurred again. Analytically, we notice in this example that the constituents were all present in the process--the source, the message, the channel, and the receiver. Although the source and receiver alternated and the messages from the two communicators were different, the channel--sound waves through the air--remained the same. Conceivably, one or both of the communicators could have written the message in a note rather than have spoken it.

Communication worked in this instance, but it does not work in all instances. For example, if you do not know what you want to say, your encoding mechanism cannot be instructed to transmit a message. A further difficulty may arise from the way you perceive another individual in relation to yourself. Suppose you thought that you held a higher social or economic status. Your encoder might transmit something like "Good day, I am Dr. Manners." Suppose you wanted to



lay the groundwork for future contact. Your encoder might transmit "Hi, I'm Sam," a less intimidating statement than the preceding one.

Another problem inherent in the communication process is the possibility that the encoder, deficient in some way, might substitute the wrong sounds in the process of transmission. Your message could come out, "Hello, my game is Ham." This could lead to embarrassment. But if the receiver's decoding system were faulty, she might hear, "Hello, my what a dame!" Or the communication channel might be overloaded with hundreds of other people speaking simultaneously throughout the assembly hall, and Susan would not hear you. One other possibility is that the cultural norms of Susan's society might not permit her to respond to a stranger. Your communication would be ineffective.

Although we have discussed a fairly uncomplicated situation, the process analysis approach to communication provides a frame of reference for looking at the most complex communication situations, whether interpersonal or mass.

### **SELF ASSESSMENT EXERCISE 3**

Highlight and briefly discuss the major challenges that are militating against the communication process

## **4.0 CONCLUSION**

The source is oftentimes referred to as the chief communicator because without it nothing is done in the communication process. The source is influenced by its communication skill, knowledge level, socio-cultural context and attitude. Equally, the medium is important. Marshall McLuhan argues that the medium is the message. A message of the same content and quality that passes through CNN and NTA will definitely have different meaning and impact on the audience. However, the choice of medium is determined by availability of the medium to the communicator, cost of using the medium, choice, and audience of the medium, credibility of the medium in terms of respect and integrity and adaptability to message being disseminated.

## **5.0 SUMMARY**

This unit has explored the nitty gritty of the communication process, vis-a-vis, the process and the elements. The unit equally attempted a thorough analysis of the communication process, with particular emphasis on the factors that influence the communication process.

## 6.0 TUTOR-MARKED ASSIGNMENT

What is the impact of the medium on messages communicated? Will a message communicated through CNN be much more impactful than that communicated through NTA? Give convincing reasons for your answer.

## 7.0 REFERENCES/FURTHER READINGS

Baran, S.J. (2002). *Introduction to Mass Communication*. New York: McGraw Hill.

Bitner, R. (1989). *Mass Communication: An Introduction*. New Jersey: Prentice Hall.

Sambe J.A.. *Introduction to Mass Communication Practice in Nigeria*. Ibadan: Spectrum Books Limited

## **UNIT 4 MODELS OF COMMUNICATION**

### **CONTENTS**

- 1.0 Introduction
- 2.0 Objectives
- 3.0 Main Content
  - 3.1 Aristotle and Lasswell Models
  - 3.2 Shannon and Weaver's Model
  - 3.3 Schramm
  - 3.4 HUB Model
- 4.0 Conclusion
- 5.0 Summary
- 6.0 Tutor-Marked Assignment
- 7.0 References/Further Readings

### **1.0 INTRODUCTION**

This unit exposes students to the variety of ways through which communication could be conceptualized and examined. The models mentioned in this unit are named after their originators. In this unit, students shall see how the models could be used to understand the concept of communication better. Specifically, the models are categorized under the following:

- 1) Aristotle and Lasswell Models
- 2) Shannon and Weaver's Model
- 3) Schramm
- 4) HUB Model

### **2.0 OBJECTIVES**

At the end of this unit, you should be able to:

- explain the various models used in understanding or interpreting the concept and process of communication
- apply such models to particular situations and issues surrounding the field of communication.

### **3.0 MAIN CONTENT**

A model is a symbolic representation that shows how elements of a structure or system relate for analysis and discussion purposes. Communication models help to explain the process of communication.

### 3.1 Aristotle's Model

Aristotle, writing 300 years before the birth of Christ, provided an explanation of oral communication that is still worthy of attention. He called the study of communication "**rhetoric**" and spoke of three elements within the process. He provided us with this insight: Rhetoric falls into three divisions, determined by the three classes of listeners to speeches. Of the three elements in speech-making — speaker, subject, and person addressed — it is the last one, the hearer, that determines the speech's end and object. Here, Aristotle speaks of a communication process composed of a speaker, a message and a listener. Note, he points out that the person at the end of the communication process *holds the key to whether or not communication takes place*.

#### LASSWELL'S MODEL

Harold Lasswell (1948), in proposing a convenient way to describe communication, came out with the model which was expressed in terms of the basic elements of the communication process. According to Lasswell, communication occurs when:

- a source sends a message
- through a medium
- to a receiver
- producing some effect

Lasswell proposed a verbal model to describe the process through which communication works. The model requires answer to the following questions:

- Who
- Says what
- In which channel
- To whom
- With what effect?

The point in Lasswell's comment is that *there must be an "effect" if communication takes place*. If we have communicated, we've "motivated" or produced an effect. It is also interesting to note that Lasswell's version of the communication process mentions four parts — who, what, channel, whom. Three of the four parallel parts mentioned by Aristotle — speaker (who), subject (what), person addressed (whom). Only channel has been added.

## SELF ASSESSMENT EXERCISE 1

Identify and discuss the major difference between Aristotle and Lasswell's Model?

### 3.2 Shannon and Weaver's Model

Claude Shannon developed this model while trying to know what happens to "information bits" as they travel from the source to the receiver in telephone communication. In the process, he isolated the key elements of the Communication process, but missed out feedback which was later added by his colleague, Warren Weaver.

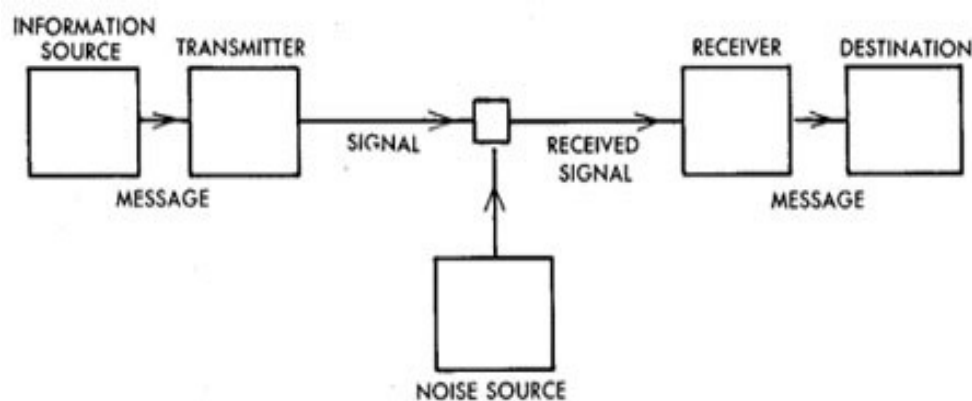

*Figure 1: SHANNON AND WEAVER'S MODEL*

The elements include:

- a) The Communication: All communication are composed of chains or systems; and a system or chain is no stronger than its weakest link.
- b) The information and communication source: The entity (individual, group or organisation) that originates the message.
- c) The Message: The information itself, which may be verbal or non-verbal, visual, auditory, or tactile.
- d) The Transmitter: The person, establishment (or equipment) that encodes and transmits the message on behalf of the source; the transmitter may be the source.
- e) The Channel: The avenue through which the message is transmitted to the receiver.
- f) The Destination: the central nervous system (e.g. the human brain) where the message is processed for final use.

- g) Noise: This is anything added to the information signal but not intended by the information source, and therefore causing distortion in the message.

Shannon and Weaver attempted to do two things:

- 1) reduce the communication process to a set of mathematical formulas and
- 2) discuss problems that could be handled with the model.

Shannon and Weaver were not particularly interested in the sociological or psychological aspects of communication. Instead, they wanted to devise a communication system with as close to 100 percent efficiency as possible.

The "noise" concept introduced by Shannon and Weaver can be used to illustrate "semantic noise" that interferes with communication. You will note that the Shannon and Weaver diagram has essentially the same parts as the one formulated by Aristotle. It's true the parts have different names, and a fourth component — in this case the transmitter — is included.

## **SELF ASSESSMENT EXERCISE 2**

How complementary is the efforts of Warren Weaver to the initial efforts of Claude Shannon in their bid to know what happens to "information bits" as they travel from the source to the receiver in telephone communication.

### **3.3 Schramm's Model**

This model made a clear case for delayed feedbacks in mass communication.

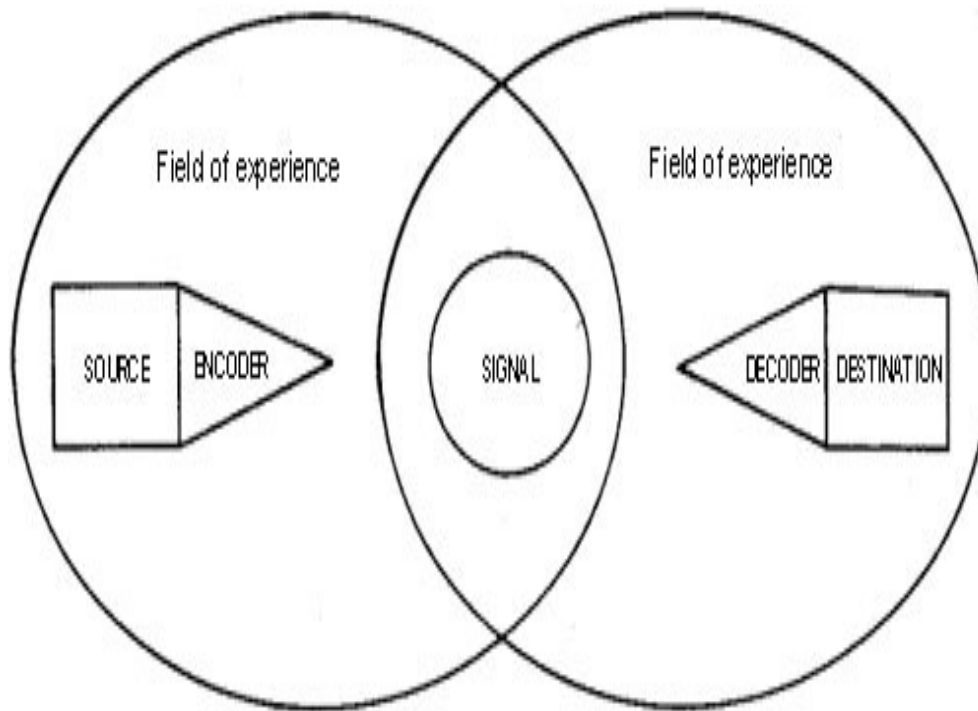
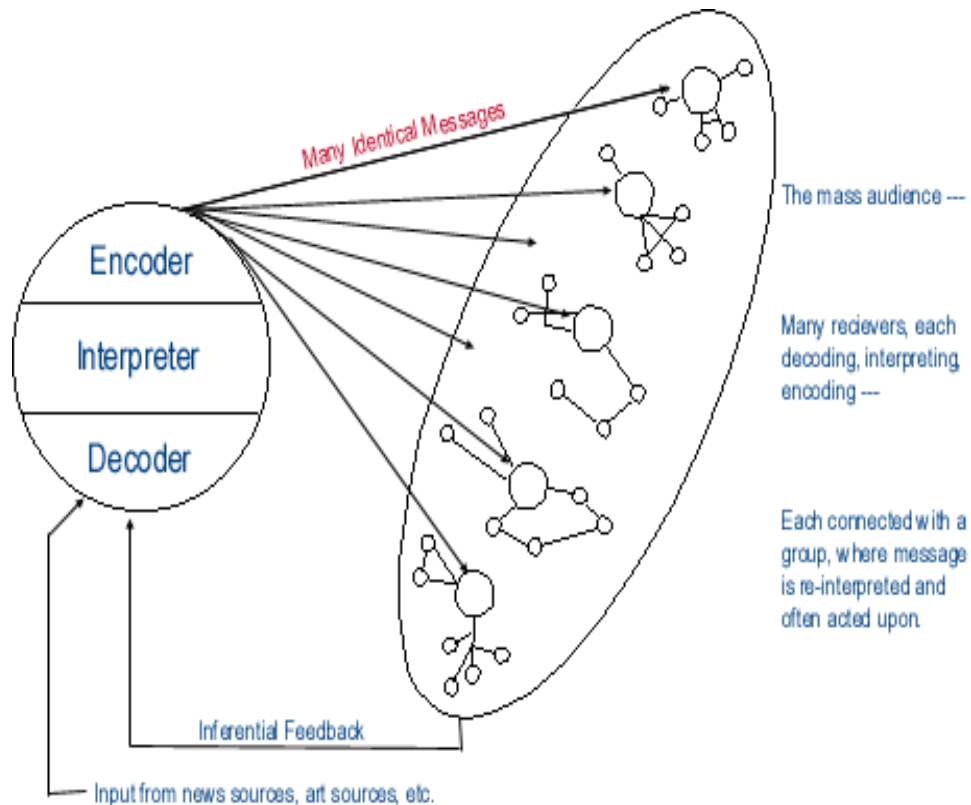

**Fig. 2 SCHRAMM'S MODEL OF MASS COMMUNICATION**

Wilbur Schramm, a well-known communications theorist, developed a straightforward communications model. In Schramm's model he notes, as did Aristotle, that communication always requires three elements — the source, the message and the destination. Ideally, the source encodes a message and transmits it to its destination via some channel, where the message is received and decoded.

However, taking the sociological aspects involved in communication into consideration, Schramm points out that for understanding to take place between the source and the destination, they must have something in common. *If the source's and destination's fields of experience overlap, communication can take place.* If there is no overlap, or only a small area in common, communication is difficult, if not impossible.

Schramm also formulated a model that explains the process involved in mass communication.



**Fig. 3 SCHRAMM'S MODEL OF MASS COMMUNICATION 2**

The figure above depicts in graphical manner the particular aspects of the mass communication process. This model is different from other models of mass communication in that while the original model has 'message', the mass communication model offers 'many identical messages.' Besides, the model specifies 'feedback'. The feedback is represented by a dotted line labeled *delayed inferential feedback*. (Baran 2002)

### SELF ASSESSMENT EXERCISE 3

Schramm's model of communication posits that communication is interactive and interpretive. Discuss

### 3.4 The Hub Model

Hiebert, Ungurait and Bohn designed the model. It shows mass communication process as circular, dynamic and ongoing. It pictures communication as a process similar to the series of actions that take place when one drops a pebble into a pool. The pebble causes a ripple which expands outward until it reaches the shore and then bounces backward to the centre. The content of communication {an idea or event} is like a pebble dropped into the pool of human affairs. So, many



factors affect the message as it ripples out to its audience and bounces back.

The model pictures communication, codes, gatekeepers, media, regulators, filters and audiences as concentric circles through which the content {or message} must pass. Feedback is the echo that bounces back to communication while noise and amplification can both affect the message and the feedback as they travel these steps in the process.

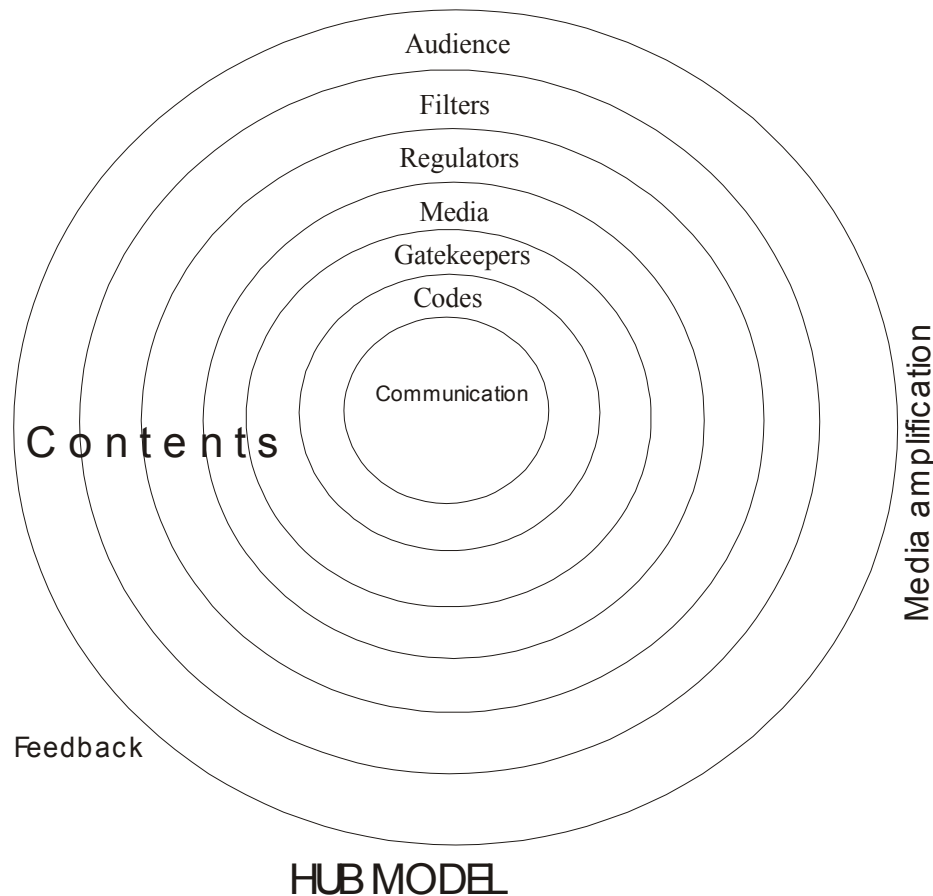

**Fig. 4: HUB model of communication**

#### **SELF ASSESSMENT EXERCISE 4**

Give a detailed explanation of the concentric analogy used in the HBU model

#### **4.0 CONCLUSION**

Communication models are designed to better explain communication theories and concepts. Models are communication tools that illustrate communication behaviour. They range from the very simple to the very

complex. The underlying ideas represented by these models are not anything new or hard to understand. They are simply the common sense realities of communication revealed in a diagram (Black, Bryant & Thompson 1998:22)

## **5.0 SUMMARY**

This unit has examined some models of communication and established the fact that these models are used to better understand the process of communication. Models examined include: Aristotle model, Lasswell model, Shannon and Weaver's Model, Schramm model and the HUB model. The unit equally examined the weaknesses and strength of each of the models and attempted to use them to better explain the process of communication.

## **6.0 TUTOR-MARKED ASSIGNMENT**

Examine the various models discussed in this unit, what are their weaknesses and strength? Make a case for your favourite model and give reasons for your choice.

## **7.0 REFERENCES/FURTHER READINGS**

Black, Bryant & Thompson (1998). *Introduction to Media Communication*. Boston: McGraw Hill.

Bitner, R. (1989). *Mass Communication: An Introduction*. New Jersey: Prentice Hall.

Sambe J.A. (2005). *Introduction to Mass Communication Practice in Nigeria*. Ibadan: Spectrum Books Limited.

## **UNIT 5 THEORIES OF MASS COMMUNICATION**

### **CONTENTS**

1.0 Introduction

2.0 Objective

3.0 Main Content

3.1 Understanding Theory

3.2 Normative Theories

3.3 Mass Society Theories (All-Powerful Media Effect)

3.4 Social Scientific Approach (Limited Effects Theories)

3.5 Theories of Media, Culture and Society

3.6 Active Audience -Uses and Gratification Theory

3.7 Media Violence. Children and Effects

3.8 Common Sense Theories

4.0 Conclusion

5.0 Summary

6.0 Tutor-Marked Assignment

7.0 References/Further Readings

### **1.0 INTRODUCTION**

Theory is a conceptual representation or explanation of phenomenon. They are stories about how and why events occur. Kurt Lewin defines theory as a way of explaining the ordering and occurrence of various events. It can also be defined as a set of systematic generalizations based on scientific observation and leading to further empirical observation. (Severin and Tankard (Jnr.) 1982).

### **2.0 OBJECTIVE**

This unit exposes students to various mass communication theories, their origins, methods and uses. Students should be able to identify a theory that goes along with specific research studies in order to develop a theoretical framework for such.

### **3.0 MAIN CONTENT**

#### **3.1 Understanding Theory**

##### **3.1.1 Characteristics of Theory**

These are some of the characteristics of theory and they could also be seen as criteria for a good theory.

### **A) Scientific Criteria**

- (1) Intellectual Rigour: - Every theory is a product of careful analysis and giving great attention to details. This process ensures that they are testable, verifiable or systematic.
- (2) Dynamism: - Theories are subject to change; they are seldom constant because they can be modified or completely repudiated when new facts emerge.
- (3) Predictive power: Theories enable us to make predictions but those predictions are rarely ever realized with exactitude. Theory is step behind reality.
- (4) Economy: A good theory explains many cases with a few statements and with few exceptions, if any.
- (5) Explanatory Power: ability of a theory to be used to explain a puzzling phenomenon
- (6) Internal Consistency: There should be no contradiction in the process. The processes involved should agree with one another.
- (7) Heuristic Potential: Should help to see a new thing or new things; or should be useful for solving problems.
- (8) Practical Utility. Theories have usefulness to reality. They can be used to solve real life problems and issues

### **B) Aesthetic/Humanistic Criteria**

- 1) Fresh (New) understanding of the human condition.
- 2) Societal value- capacity to stimulate or generate change/clarification of values.
- 3) Aesthetic appeal- capacity to capture our interest/imagination or pique our curiosity.
- 4) Community agreement- acceptance and support by a “community” of (like-minded) scholars.
- 5) Capacity for social reforms. Ability to carry out useful reforms and changes in the society. The changes are mostly socio-economic in nature.

### **3.1.2 Why Study Theories?**

Theories help to manage realities. Kurt Lewin says that theories enable us to put facts in perspective, and to predict what will happen, even before the events we are theorising about get completed. According to Kaplan, a theory enables us to make sense out of a disturbing situation. e.g. Detectives (Police) always formulate a theory to unravel a case, say murder case. We also study theories in order to derive intellectual satisfaction.

### 3.1.3 How Theories are arrived at

Theories are derived through a process known as scientific method. The process includes:

1. **Conceptualisation:** This is the definition of the subject of inquiry. You may call it a topic of research.
2. **Operationalisation:** This involves translation of general concepts into specific variables and specification of the procedure adopted in research. (From problem statement to generalisation)
3. **Observation:** This is the careful study (observation) of the specified variables from available data, using any modes of research.
4. **Analysis:** This involves extracting meaning from the facts observed. This must be done objectively.
5. **Testing:** Here, the results of analysis are used to test the hypothesis or research questions raised in a study.
6. **Generalisation:** The findings from the test are used to make some generalisations, regarding the subject of inquiry.
7. **Theory:** Theories are formulated from the generalisation made as a result of our analysis and testing.
8. **Law:** Theory eventually leads to law after it has been repeatedly tested without being disproved or substantially modified. Laws are difficult to come by in social sciences because we study human organisation and behaviour, which are capricious.

From the foregoing it can be seen that theory and research are closely linked.

### 3.1.4 Relationship between Theory and Research

It is already seen from the above that theory and research are closely related through the scientific method. Both theory and research may be seen as two sides of the same coin. Any scientific assertion needs to have both logical and empirical support; that is, it must make sense and align with observations in the real world. Theory provides the logical support while research provides the empirical (observation) support.

### SELF ASSESSMENT EXERCISE 1

What is the end product of research?

### **3.2 Normative Theory**

This is a type of theory that describes an ideal way for media systems to be structured and operated. Normative theories do not describe things as they are nor do they provide scientific explanations; instead, they describe the way things shall be if some ideal values or principles are to be realised. They help to explain the way in which social communication rules impinge on mass media structures, conventions and performance, and highlight the consequences of non-convergence between societal communication principles and mass communication principles. They include:

#### **3.2.1 Authoritarian Media Theory**

This is the oldest of the press theories. It is an idea that placed all forms of communication under the control of a governing elite or authorities. Authorities justified their control as a means to protect and preserve a divinely ordained social order. It actually began in 16<sup>th</sup> century Europe—a period when feudal aristocracies exercised arbitrary power over the lives of most people. It derived from State's philosophy of absolutism, in which recognition of truth was entrusted to only a small number of 'sages' who are able to exercise leadership in a top-down approach.

It advocates the complete domination of media by a government for the purpose of forcing the media to serve the government; and the media were forbidden to criticise the government or its functionaries. The media in an authoritarian system are not allowed to print or broadcast anything which could undermine the established authority, and any offense to the existing political values is avoided. The authoritarian government may go to the extent of punishing anyone who questions the state's ideology.

The fundamental assumption of the authoritarian system is that the government is infallible. Media professionals are therefore not allowed to have any independence within the media organization. Also foreign media are subordinate to the established authority, in that all imported media products are controlled by the state. Authoritarian media still operate today in countries where the press is largely owned or controlled by government (mostly repressive government).

The instruments of authoritarian control include, repressive legislation and decrees, heavy taxation, direct or subtle control of staffing and of essential production inputs like newsprints, prior censorship and

suspension of production. The relationship between the state and the media in an authoritarian system can be illustrated as such:



**N.B: Gvt means Government**

### 3.2.2 Libertarian Media Theory (Free Press Theory)

Libertarian thought emerged out of the authoritarian theory, when some social movements, including Protestant Reformation, demanded greater freedom for individuals over their own lives and thoughts. It prescribes that an individual should be free to publish what he or she likes and to hold and express opinions freely. It sees the press as a free ‘market place’ of ideas- that all ideas should be put before the public, and the public will choose the best from that ‘market place’ (Milton Self-righting principles).

Libertarian theory does not advocate media immunity to the rule of law but asserts that people should be seen as rational beings able to distinguish between good and bad, truth and falsehood- which renders prior censorship of media unnecessary. As a matter of fact, in the libertarian system, attacks on the government's policies are fully accepted and even encouraged. Moreover, there should be no restrictions on import or export of media messages across the national frontiers. Moreover, journalists and media professionals ought to have full autonomy within the media organization. It also advocates that the press be seen as partner in progress with the government in the search for truth, rather than a tool in the hands of government.

It is hard to find intact examples of libertarian media systems in today's world. Though the clearest expression of free press theory is found in the First Amendment of the American Constitution which states “Congress shall make no law ... abridging the freedom of speech or of the press”, but the U S media system has tendencies of authoritarianism as well.

The illustration below shows that there is no explicit connection between the government and the media in the libertarian theory:

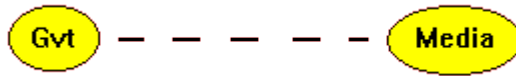

### 3.3.3 Soviet-Communist Media Theory

From its name, the *Soviet* theory is closely tied to a specific ideology; the communist. Siebert traces the roots of this theory back to the 1917 Russian Revolution based on the postulates of Marx and Engels. The media organizations in this system were not intended to be privately owned and were to serve the interests of the working class.

It advocates the complete domination of media by a communist government for the purpose of forcing those media to serve the party. The main task of the press is to promote the socialist system and maintain the sovereignty of the proletariat (working class) via communist party.

While the soviet-communist theory seeks to use the media to support development and change towards the attainment of the communist stage, the authoritarian seeks to use the media to maintain the status quo. But they are similar in subjecting the media to direct state control. Every issue in Soviet communist must be seen and interpreted in favour of the communist party. The four working principles of soviet press are (1) Truthfulness. (2) Partiality. (3) Commitment to the people. (4) Mass culture.

Libertarian and Social Responsibility theories assign economic function to the press while the Soviet press removes the profit motive since it is an arm of government and financed by government. Libertarian and Social Responsibility theories expect the media to raise social conflict to the level of discussion but Soviet theory forbade organisation of press structure along the lines of political conflicts since social societies aspired to become “classless societies”.





An illustration of the Soviet system would appear to be the same as the authoritarian model, in that both theories acknowledge the government as superior to the media institutions. However, there is a major difference between the two theories that needs to be clarified: The mass media in the Soviet model are expected to be self-regulatory with regard to the content of their messages. Also, the Soviet theory differs from the authoritarian theory in that the media organizations have a certain responsibility to meet the wishes of their audience. Still, the underlying standard is to provide a complete and objective view of the world according to Marxist-Leninist principles.

### **3.2.4. Social Responsibility Media Theory**

Social Responsibility Theory emerged as a result of conflict between professionalism and self-regulation of the press and pressure for greater regulation of the media. In response, Henry Luce, CEO of Time Inc. provided funding for an independent commission to make recommendations concerning the role of the press. The Hutchins Commission on Freedom of the press was established in 1942 and released its report in 1947.

The Commission members were sharply divided between those who held strongly libertarian views and those who supported some form of press regulation. Press regulation advocates argued that anti-democratic press can easily subvert the “market place of ideas” and use the media to transmit propaganda to fuel hatred for their own advantages. (e.g. Hitler used the media against the Jew). On the other hand, placing the media under a control or regulation will hinder the freedom of the press.

The Commission therefore decided to place their faith in media practitioners and called on them to redoubled their efforts to serve the public and that the media have certain obligations to society. These obligations were expressed in the words "informativeness, truth, accuracy, objectivity, and balance"

This theory states that the media can be used by anyone who has an idea to express but they are forbidden to invade private rights or disrupt social structures. It emphasizes the freedom of the press and places responsibility on the media practitioners to abide by certain social standards. It opposes media regulation but believes that the press is automatically controlled by community opinion, consumer protest and professional ethics.

It calls on the media to be responsible for fostering productive and creative “Great Communities” (Baran and Davis 2003:109), and that media should do this by prioritising cultural pluralism- by becoming the

voice of all the people – not just elite groups or groups that had dominated national, regional or local culture in the past. It also points out that the media, in carrying out their obligations, must adhere to the highest ethical standards.

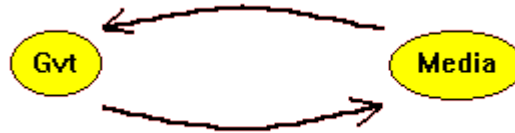

Social Responsibility Theory basic principles, summarised by McQuail (1987), include:

- To serve the political system by making information, discussion and consideration of public affairs generally accessible.
- To inform the public to enable it to take self determined action.
- To protect the rights of the individual by acting as watchdog over the government.
- To serve the economic system; for instance by bringing together buyers and sellers through the medium of advertising.
- To provide “good” entertainment, whatever “good” may mean in the culture at any point in time.
- To preserve financial autonomy in order not to become dependent on special interests and influences.

### 3.2.5 Democratic-Participant Media Theory

This theory advocates media support for cultural pluralism at a grass-roots level. The media are to be used to stimulate and empower pluralistic groups. It calls for development of innovative “small” media that can be directly controlled by group members. In other words, the existing bureaucracy, commercialisation and professional hegemony in media system should be broken down to allow or guarantee easy media access to all potential users and consumers.

The theory reflects disappointment with Libertarian and Social Responsibility theories for failing to deliver social benefits expected of them. It condemns the commercialisation and monopolisation of private owned media and the concentration and bureaucratization of government owned media. It also criticises the public media for being too elitist, too susceptible to the whims and caprices of the government, too rigid and too slavish to professional ideals at the expense of social responsibility

It therefore calls for greater attention of the media to the needs, interests and aspirations of the receiver in a political society. It calls for pluralism in the place of monopolisation, decentralisation and localisation in the

place of centralism. Also that media conglomerates be replaced or mixed with small-scale media enterprises. It also calls for “horizontal” in place of top-down communication to ensure feedback and complete communication circuit. However it holds that the mass media have become too socially important to be left in the hands of professionals.

### **3.2.6 Development Media Theory**

Development media theory advocates media support for an existing political regime and its efforts to bring about national economic development. It argues that until a nation is well established and its economic development well underway, media must be supportive rather than critical of government. Journalists must not tear apart government efforts to promote development but, rather, assist government in implementing such policies.

The duty of the press practicing this theory is to promote development. It also emphasises grassroots participation. The tenets of this theory are:

1. Media must accept and carry out positive development tasks in line with nationally established policy.
2. Freedom of the media should be open to economic priorities and development needs of the society
3. Media should give priority in their content to the national culture and language(s). The media should also give priority of coverage to other development countries.
4. Media should give priority in news and information to link with other developing countries that are close geographically, culturally or politically.
5. Journalists and other media workers have responsibilities as well as freedoms in their information gathering and dissemination tasks.
6. In the interest of development ends the state has a right to intervene in, or restrict, media operation; and devices of censorship, subsidy and direct control can be justified.

### **SELF ASSESSMENT EXERCISE 2**

Normative theory seeks to locate media structure and performance within the milieu in which it operates. Explain.

### **3.2 Mass Society Theories (All-Powerful Media Effect)**

These are perspectives that stress the influential but often negative role of the media. They believe that the media are corrupting influences that undermine the social order and that average people are defenseless against their influence. These theories emerged in the second half of the

19<sup>th</sup> Century when mass circulation of newspapers and magazines, movies, talkies, and radio came to prominence. It was a time of urbanization and industrialization spread; which in conjunction with the media altered the society's patterns of life. The theories are treated below:

### 3.3.1 Hypodermic Needle/ Magic Bullet Theory

This was a media theory that saw the media as all-powerful and supremely effective; and believed that all human beings responded the same way to the powerful influence from the media. The theory was a propaganda theory, produced by a combination of Behaviourist and Freudian schools of thought. Behaviourism held that human action was as a result of or response to external environmental stimuli. It argued that the so-called consciousness was meant to rationalise behaviours after they were triggered by the external stimuli.

Freudianism saw the self that controls human action as having three parts: **Ego**- rational mind; **Id**- pleasure seeking part of the mind and **Superego**- internalised set of cultural rules. It said the human action was often the product of the darker side of the self -the Id-, which is the pleasure-seeking part of the mind. By appealing to the Id, so that it could overcome the ego, then, propaganda would be effective.

So, the Magic Bullet saw the media as conveying external stimuli that can condition anyone to behave in whatever way a master propagandist wants. People were viewed as powerless to consciously resist manipulation no matter their level of education or social status. The rational mind was viewed as a mere façade, incapable of resisting powerful messages. People had no ability to screen out or criticise these messages. The messages penetrate to their subconscious mind, and transform how they think and feel.

#### Early mass communication model

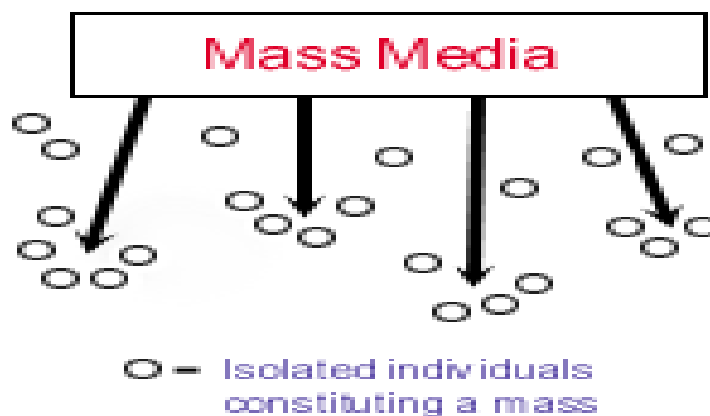

### 3.3.2 Lasswell's Propaganda Theory

During the troubled decade of the 1930s, one of the first communication theorists, Harold Lasswell, proposed a theory that attempted to explain disturbing events of the times. Lasswell argued that the worldwide economic depression and political strife had made people particularly vulnerable to propaganda conveyed by the mass media. He posited that the power of propaganda was not so much the result of the substance or appeal of specific messages but, rather, the result of the vulnerable state of mind of average people.

Unlike the Magic Bullet Theory's prediction of rapid and powerful persuasive effects of the mass media, this Propaganda Theory said that mediated propaganda conditioned the audience slowly over time. Propaganda works through projection of *master symbols*, emotion-charged images (for example, a national flag). Lasswell's depiction of the working mechanism of propaganda was especially prescient in Germany. The National Social Party (Nazis) under Adolph Hitler took control of the German government in 1933 and launched a systematic campaign of propaganda to win popular support for its policies. Joseph Goebbels Propaganda Ministry produced propaganda films to promote the party's militarism and anti-Semitism. A network of carefully-crafted Nazi master symbols included the swastika, the "Zeig-Heil" gesture, German ascendancy from a mythical Aryan race, and a fictitious Jewish conspiracy. Reinforced by terrorist tactics of the secret police, the propaganda helped to firm a Nazi grip on the highly educated German people.

The Propaganda Theory ascribed great persuasive power to a technocratic elite. Influential newspaper columnist Walter Lippmann, author of the first book on public opinion (1922), thought that propaganda so threatened democracy that the mass media must be censored to protect the public from their powerful influences. Later theorists decided that people are not so gullible and that the 1930s was a unique era.

### 3.3.3 Lippman's Theory of Public Opinion Formation

The theory stressed the inability of average people to make sense of their world and make rational decisions about their actions. Eric Alterman quoted and summarized Lippman's position that average citizen can be compared

*to a deaf spectator sitting in the back row. He does not know what is happening, why it is happening, what ought to happen. "He lives in a world he cannot see, does not understand and is unable to direct."...No one expects a*

*steelworker to understand physics, so why should he be expected to understand politics?*

Lippman did not believe in the Libertarian assumptions of the rational audience; he thus advocated the placement of control of information gathering and distribution in the hands of a benevolent technocracy- a scientist elite- that could be trusted to use scientific methods to sort fact from fiction and make good decisions about who should receive various messages.

### **SELF ASSESSMENT EXERCISE 3**

How powerful is the bullet theory? Why is it referred to as all powerful?

### **3.4 Social-Scientific Theories (Limited Effects Theories)**

Social scientific theories are generalisations derived from systematic observation and objective analysis of mass media variables, by employing methods associated with empirical research in the social sciences. Methods such as experimentation, field surveys, content analysis, focus group etc are used. The social scientific approach to investigating the effects of the media led to the emergence of limited effects theories. The theories include the following:

#### **3.4.1 The Post Stimuli-Response theory**

- ***The Individual Differences Perspective***

It argues that because people vary greatly in their psychological compositions and because they have different perceptions of things, media influence differs from person to person. In other words, people learn attitude, values and beliefs in the context of experience and this result in differences in the way they understand and perceive media messages.

- ***The Social Category Perspective***

It assumes that members of a given social category will respond to media stimuli in more or less uniform ways. In other words, people with similar backgrounds {e.g. age, gender, and income level, religious affiliations} will have similar reactions to that exposure.

- ***The Social Relations Perspective***

It posits that people's reaction to media messages is modified by their informal social relationships with significant others like relations, friends, social groups etc.

### 3.4.2 The Two-Step Flow Theory

It states that media messages pass through opinion leaders to opinion followers. It was discovered during election campaign that many people had little exposure to the mass media, such people obtained their information second hand from people {opinion leaders} who got it from the media and also shaped it as they passed it down. The people's voting decision was based on their second hand information which has been modified by the opinion leaders.

The Two-Step flow was later modified to Multi-Step or N-Step flow theory, since opinion leaders also have opinion leaders and so on continuously.

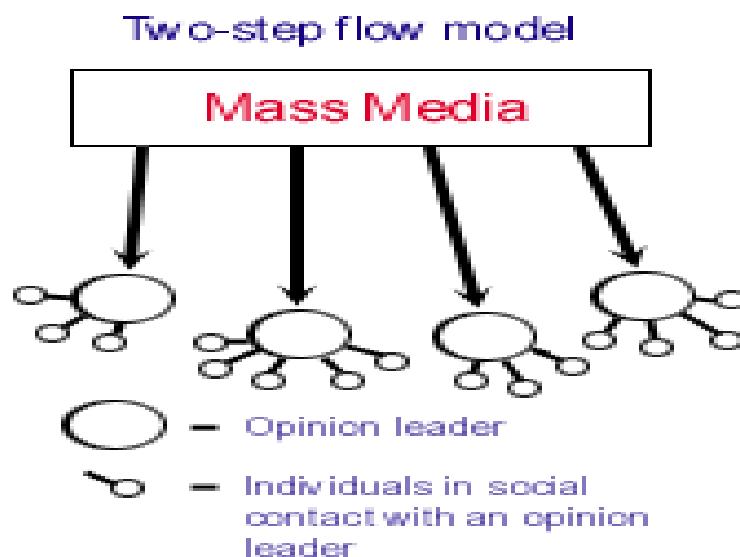

### 3.4.3 Dissonance Theory (Selective Processes)

Dissonance theory further corroborates the fact that the media are not all-powerful as the belief was in the mass society era. The idea in dissonance theory is that any information that is not consistent with a person's already-held values and beliefs will create a psychological discomfort (dissonance) that must be relieved; this is because people generally work to keep their knowledge of themselves and the world consistent with their preexisting beliefs. What may happen at times is for a person to try as much as possible to make some things that are not psychologically nor consistently aligned (consistent) to his values and

beliefs through a variety of ways. The ‘ways’ of doing this have become known as the **selective processes**.

Some psychologists see selective process as defence mechanism used to protect ourselves {and our ego} from information that would threaten us, while others consider it as a normal means for coping with the large quantity of sensory information that constantly bombard us. Whatever it may be, there is no doubt that it functions as complex and highly sophisticated filtering mechanism that screen out useless sensory data while it identifies and highlights those that are useful in the data.

Klapper (1960) explains that selective process helps media content consumers to cope with media’s impact. Generally, people tend to expose themselves to those mass communications that are in accord with their existing attitudes and interests; while they consciously and unconsciously avoid communications of opposite hue. However, when exposed to such communications, they often seem not to perceive it, or recast and interpret it to fit their existing views.

### **Selective Exposure**

This is people’s tendency to seek out information that supports their interest, confirms their beliefs and boosts their ego while avoiding those that are contrary to their predispositions. In other words, receivers choose exposure to ideas that reinforce and confirm already held beliefs and attitudes e.g. As a christian, you may have the tendency to read books or watch films that support your religion while you avoid another religion’s materials, say Islamic religion.

### **Selective Attention**

As a result of too much barrage of information that bombard us, we tend to attend to media messages that we feel are in accord with our already held attitudes and interests, while we filter those ones that do not cater for us.

### **Selective Perception**

This is the mental recasting of a message so that its meaning is in line with a person’s beliefs and attitudes. It is a psychological process, which involves decoding of communication messages and ensuring that they align with your previous experiences and current dispositions – needs, moods and memories.



## **Selective Pretention**

This is the process by which people tend to remember best and longest information that is consistent with their pre-existing attitudes or interests.

## **SELF ASSESSMENT EXERCISE 4**

Why are the Social-Scientific Theories referred to as the Limited Effects Theories?

### **3.5 Theories of Media, Culture and Society**

The theories under consideration here offer cogent and insightful analyses of the role of the media in both culture and society. These theories argue that the structure and content of our media system both reflect and create our overall social structure and our culture. They include the following:

#### **3.5.1 Agenda Setting Theory**

This posits that the mass media determines the issues that are regarded as important at a given time in a given society. That means that the press is significantly more than a purveyor of information and opinion; and though it may not be able to tell its readers what it thinks, it does successfully tell them what to think about. In other words, our perception of the world is dependent not only on our personal interests, but also on the map that is drawn for us by the media.

Maxwell McCombs and Donald Shaw (1972) corroborate the agenda setting theory by their research. They posit that:

*In choosing and displaying news, editors, newsroom staff, and broadcasters play an important part in shaping political reality. Readers learn not only about a given issue, but how much importance to attach to that issue from the amount of information in a news story and its position ...The mass media may well determine the important issues- that is, the media set the 'agenda' of the campaign. (p.176)*

The elements involved in agenda setting include:

- (1) The quality or frequency of reporting
- (2) Prominence given to the reports – headlines display, layout, timing on radio and TV set
- (3) The degree of conflict generated in the reports
- (4) Cumulative media-specific effects over time

### 3.5.2 Main Streaming/Synchronisation Theory

This theory explains the process, especially for heavier viewers, by which television's symbols monopolise and dominate other sources of information and ideas about the world.

There are two aspects to mainstreaming:

**Message Analysis:** involves detailed content analysis of selected media content {especially television programming} to assess recurring and consistent presentation of images, themes, value, and portrayals.

**Cultivation Analysis:** observation of the effects of the messages.

The assumption here is that television creates a worldview that, although possibly inaccurate, becomes the reality because people believe it is to be so. In other words, the more time people spend watching television, the more their world views will be like those spread by television.

You may like to examine the presentation of violence on television; is there as much violence in reality as the presentation is on television? What of the roles assigned to sex {gender} on television: are men presented as dynamic and aggressive while women are portrayed as passive and domestic? What of strike actions in Nigeria, how has the media presented it? Who is the winner or loser between government and labour? On the international scene, Africa is presented as a region of war, chaos, famine and HIV- is it actually true?

### 3.5.3 The Knowledge Gap Theory

This theory establishes that the media systematically inform some segments of the population; especially those in higher socio-economic groups, better than they inform others. Therefore, the differences between the better informed and the less informed groups tend to grow and become bigger and bigger.

In other words, as the media output increases, rather than balancing the differences between the information rich and the information poor, it

enlarges the differences, because those at the higher socio-economic levels acquire information much faster and much more easily than those at the lower levels.

However, the theory also states the possibility of the gap being narrowed. This may happen if the information rich become 'sated', that is they have got enough and do not seek for or need more, while the information poor continue to search till they catch up with the information rich.

### **3.5.4 Spiral of Silence Theory**

It describes the tendency for people holding views contrary to those dominant in the media to keep them to themselves for fear of rejection. An opinion spreads from media to people and people are encouraged either to proclaim their views or to swallow them and keep quiet until, in spiraling process, the one view dominates the public scene and the other disappears from public awareness as its adherents became mute. In other words, because of people's fear of isolation or separation from those around them, they tend to keep their attitudes to themselves when they think they are in the minority.

The point in the theory is that ideas, occurrences and persons exist in public awareness practically only if they are given sufficient publicity by the mass media, and only in the shapes that the media ascribe to them. So, people perceive issues as the media perceive them. And since society rewards conformity and punishes deviance, the fear of isolation constrains people to conform to shared judgment as guarded or judged by the mass media.

Certain terms that have emerged in the process of exposition and discussion of this theory include:

1. Double Opinion Climate- the media opinion is different from public opinion
2. Silent Majority- Domination of minority opinion over majority
3. Pluralistic Ignorance – Feeling of belonging to minority whereas opposite is the case
4. Bandwagon- Tendency to belong because majority belong
5. Snob- effect- Decrease in popularity of opinion because it is believed to be cheap.

### **3.5.5 Media Systems Dependence Theory**

This theory assumes that the more an individual depends on having his/her needs gratified by media use, the more important will be the role that media play in the person's life; and therefore the more influence those media will have on that person.

The basis of media influence lies in the relationship between the larger social system, the media's role and audience relationships in that system, and audience relationship to the media. Effects occur, not because all-powerful media or omnipotent source wills that occurrence, but because the media operate in a given way in a given social system to meet a given audience wants and needs.

Audience members determine the occurrence and shape of media effect and it is related to how the audience uses the media. Since we make use of the media to make sense of our world, we permit the media to shape our expectation. Thus, the greater the need and consequently the stronger the dependency, the greater the likelihood that the media and their messages will have an effect. Media will equally influence not everyone. Those who have greater needs and thus greater dependency on media will be influenced.

### **SELF ASSESSMENT EXERCISE 5**

How can the agenda setting theory be applied during political electioneering campaign?

### **3.6 Active Audience Theories**

The preceding theories focused on the effects of the media on the audience. As new perspectives emerged, not only was the media regarded as having limited effect, attention was being drawn to what people do with media. Active audience or audience-centred theories explain or focus on what people do with the media as opposed to source-dominated theories which focus on the effects of the media on people.

#### **3.6.1 Uses and Gratification Theory**

The Uses and Gratification theory sees the audience as influencing the effect process because they selectively choose, attend to, perceive and retain the media messages. It focuses on the uses to which people put media and the gratifications they seek from that use.

In Herta Herzog's study of the use of radio soap opera, three (3) major types of gratification were identified:

1. A means of emotional release
2. Opportunities for wishful thinking – commonly recognised form of enjoyment
3. Advice obtained from listening to daytime serials – commonly unsuspected.

Wilbur Schramm provided a concept to answer the question “what determines which offerings of mass communication that will be selected by a given individual? or what determines the media content that an individual pays attention to?” The answer offered is called the **fraction of selection**:

### Expectation of Reward

### Effort Required

His point was that people weigh the level of reward (gratification) they expect from a given medium or message against how much effort they must make to secure that reward. We all make decisions about which content we choose based on our expectations of having some needs meet; but the efforts required in meeting the needs will eventually influence the decision we make.

So, individuals select the media that will likely satisfy their needs, they selectively consume the content of those media and there may or may not be any effect.

### 3.6.2 Reception Studies-Decoding and Sense Making

It focuses on how various types of audience members make sense of specific forms of content. Halls (1980a) argued that media content can be regarded as a text that is made up of signs. These signs are related to one another in specific ways. To make sense of a text –to read a text – you have to be able to interpret the signs and their structure. For example, when you read a sentence you must not only decode the individual words but you also need to interpret the overall structure of the sentence to make sense of the sentence as a whole.

He therefore identified 3 variables:

- The first is **Preferred** or **Dominant reading** – that is the meaning intended by the producer of a media message, which is meant to have a desired effect

- The second is **Negotiated** or **Alternative meaning**- that is the audience interpretation of the message that is misinterpreted or that differs from the preferred meaning
- The third is the **Oppositional decoding**- that is the audience interpretation that is in direct opposition to the dominant or preferred reading.

Therefore, though people are susceptible to domination by communication technologies, they are able to exploit contradictions that enable them to resist, recycle and redesign those technologies and people are capable of decoding and appropriating received messages and are not necessarily duped by them.

In other words, though people are exposed to the powerful/pervasive media messages, the individual ways of decoding such messages do not always allow them to be influenced.

### **SELF ASSESSMENT EXERCISE 6**

According to Toeing Herta Herzog's line of arguments, what determines the offerings of mass communication that you normally select? Or what determines the media content that you pay attention to.

### **3.7 Media Violence: Children and Effects**

We examine here some theories that summarised and offered useful insight into the media's violence effects.

#### **3.7.1 Catharsis Theory (Sublimation Theory)**

Catharsis theory states that viewing violence is sufficient to purge or at least satisfy a person's aggressive drive and, therefore, reduce the likelihood of aggressive behaviour.

In other words, viewing mediated aggression reduces people's natural aggressive drives.

Some attentions have been drawn to the weakness of this theory. When you watch couples engage in physical affection on the screen, does it reduce your sexual drive? Do media presentation of families devouring Indomie noodles purge you of your hunger drive? If viewing mediated sexual behaviour does not reduce the sex drive and viewing media presentation of people dining does not reduce our hunger, why should we assume that seeing mediated violence can satisfy an aggressive drive?

Thus, accumulated research clearly demonstrates a correlation between viewing violence and aggressive behaviour- that is, heavy viewers behave more aggressively than light viewers.

### 3.7.2 Aggressive Cues Theory

It believes that people who see mediated violence show higher levels of subsequent aggression. In other words, exposure to mass-mediated aggression increases people's level of emotional and psychological stimulation which can in turn lead to aggressive behaviour.

It is also assumed that a person's response to aggressive cues depends on whether he is experiencing frustration at the time of exposure to mass mediated violence. It also depends on whether the violence is presented as justified or not. That means if the violence is presented as unjustified, it can inhibit the actual expression of aggression through a sense of guilt.

### 3.7.3 Social Learning (Social Cognitive) Theory

Social learning theory encompasses both identification and imitation to explain how people learn through observation of others in their environment. **Identification** is a form of imitation in which copying a model, generalised beyond specific acts, springs from wanting to be and trying to be like the model with respect to some broader quality. In other words, it involves the tendency, especially by children, to identify with admired aggressive heroes and copy their behaviour whenever a relevant situation arises. **Imitation** is the direct, mechanical reproduction of behaviour.

This theory assumes that people, children especially, tend to learn aggression from the mass media and to model their behaviour after the ones displayed. When people observe media violence, they learn and imitate what is seen. The possibility of actualising what is seen is enhanced when:

1. The subject expects to be rewarded for such behaviour.
2. There is close similarity between the dramatized violence and real – life situation the subject subsequently encounters.

### 3.7.4 Reinforcement Theory

It states that mass- mediated violence simply reinforce the existing aggressive inclinations that people bring to media exposure. It is not that the media make people to be violent but they simply reinforce people's existing aggressive attitudes and behaviours.

### 3.7.5 Linkage Theory

This theory states that children tend to perceive a link between mass-mediated fantasy and concrete reality. Thus they assume a link between the two, and this tend to guide their behaviour in situations encouraging or stimulating aggressive behaviour.

### SELF ASSESSMENT EXERCISE 7

Do you believe the media is solely responsible for students' violent behaviours?

### 3.8 Commonsense (Everyday) Theories

These are derived from experiences of media consumers, but lack research backing that would have enabled them to be crystallised into valid generalisation. They emerged out of the knowledge of the media that people possess as media consumers. One of such is Mc Luhan's statement that "the medium is the message"

These are theories that emerged from experiences of media consumption, and though they are not generalisations from social-scientific inquiry, these views cannot be dismissed as nonsense. And in reality our experiences of media consumption tend to lend some validity to the views expressed.

#### 3.8.1 'Reflective-Projective' Theory

This theory was proposed by Lee Loevinger, a one-time Federal Communication (FCC) Commissioner. Loevinger says that mass media "mirror" society but the mirror they present is an ambiguous one. While the mass media themselves reflect society as an organised group, individual audience members project their own individual reflections into the images presented. This is the audience differential interpretation of the media mirror.

For example, a programme watched on TV may mean different things to different viewers according to their own experiences, attitudes and moods. Moreover, these individual audience members tend to identify with television and movie characters that are closer to their own idealised selves than to the actual selves. Loevinger also says intellectuals tend to be contemptuous of the TV mirror (TV programme offerings), because there are few or no characters or ideals therein for them to identify with.



Loevinger also pointed to the ambiguity of the media mirror. This is presumed to be a reference to the distortion caused by the “slant” peculiar to each media establishment as well as by the distortion at every stage and level of the gate keeping process, beginning with the news selection stage. The ambiguity of the media mirror and the differential perception by the audience are mutually enhancing and reinforcing. The audience differential interpretation of the media mirror looks like a variant of the perception theory, while the ambiguity of the media mirror can be linked with the gatekeeping theory.

### **3.8.2 Play Theory**

William Stephenson, a British Psychologist, proposed this theory. He divides man’s activity into work and play. Work deals with reality and production, while play deals with entertainment, relaxation or self-satisfaction. Stephenson says that people use mass communication more as play than as work, more for pleasure and entertainment than for information and improvement. For example, newspaper readers give more attention to comics, sports pages, fashion columns, human angle stories etc. than they do to hard news. Have you observed that TV viewers give more time to seeing entertainment programmes like sports, movies, fashion etc?

It is also observed that in societies that use the media mainly for propaganda, a considerable amount of entertainment is injected into the propaganda in order to retain audience attention.

### **3.8.3 Medium Theory (Channel Theory, or Media Formalism)**

The medium theory originated from Marshal McLuhan’s proposition the medium is the message, that is, the medium affects perception. With this claim, he stressed how channels differ, not only in terms of their content, but also in regard to how they awaken and alter thoughts and senses. He distinguished media by the cognitive processes each required. McLuhan popularized the idea that channels are a dominant force that must be understood to know how the media influence society and culture.

Medium theory focuses on the medium characteristics itself (like in media richness theory) rather than on what it conveys or how information is received. In medium theory, a medium is not simply a newspaper, the Internet, a digital camera and so forth. Rather, it is the symbolic environment of any communicative act. Media, apart from whatever content is transmitted, impact individuals and society. McLuhan’s point is that people adapt to their environment through a

certain balance or ratio of the senses, and the primary medium of the age brings out a particular sense ratio, thereby affecting perception.

### **SELF ASSESSMENT EXERCISE 8**

How unscientific is the common sense theory?

## **4.0 CONCLUSION**

Theories are statements, derived from scientific observation, that explain or interpret some phenomenon. Theories emerge from scientific investigation that provides explanations on the working of mass communication. Theories are arrived at through a process known as the scientific method. When this process is followed, a uniformed theory results.

However, when new facts emerge, our knowledge and understanding increase, and this often leads to a paradigm shift- a fundamental, even radical, rethinking of what we believe to be true. There are three factors that have caused a paradigm shift in mass communication theory. They are; Advances in technology or the introduction of new media; Calls for the control or regulation of the new technologies; and the need to protect democracy and culture pluralism.

Consequently, paradigm shift have produced 5 major eras of mass communication theory. They are: The era of mass society theory; the era of scientific perspective; The era of limited effect theory; The era of cultural theory and; The era of moderate effect perspectives

## **5.0 SUMMARY**

This unit has explored the theories related to mass communication. It gives a vivid understanding of the concept of theory; Characteristics of theory; Why study theory? And the relationship between theory and research. The unit classified all the needed theories into their families and treated them in appreciable detail. The families are :Normative theories; Mass Society Theories (All-powerful Media Effect); Social Scientific Approach (Limited Effects Theories); The Post Stimuli-Response theory; The Two Step Flow Theory; Dissonance theory (the selective process); Theories of Media, Culture and Society; Agenda Setting; Mainstreaming; Knowledge Gap, Spiral of Silence; Media System Dependency;

Active Audience – Uses and Gratification Theory: -Perception Study (Sense Making and Decoding), Framing and Frame Analysis, Information Processing Theory; Media Violence: Children and Effects, Catharsis; Aggressive cue; Social Learning, Linkage theory;

Reinforcement theory and the Common Sense Theories: Reflective Projective and Play Theories.

## **6.0 TUTOR-MARKED ASSIGNMENT**

Name and describe one theory each from each of the following era: The era of mass society theory; The era of scientific perspective; The era of limited effect theory; The era of cultural theory and; The era of moderate effect perspectives.

## **7.0 REFERENCES/FURTHER READINGS**

Baran, S.J. and Davis, D.K. (2003). *Mass Communication Theory: Foundations, Ferment, and Feature*. Belmont (USA): Thomson-Wardsworth.

Folarin, B. (1998/2002). *Theories of Mass Communication: An Introductory Text*. Ibadan: Stirling- Horden.

Severin, W.J. and Tankard, J.W.(Jnr) (1987). *Communication Theories: Origins, Methods and Uses*. New York: Hastings House.

McQuail D. (1989). *Mass Communication Theory: An Introductory*. London: SAGE.

Siebert, F. et al (1956). *Four Theories of the Press*. Urban III: University of Illinois Press.

## **UNIT 6 FUNCTIONS OF MASS COMMUNICATION**

### **CONTENTS**

- 1.0 Introduction
- 2.0 Objectives
- 3.0 Main Content
  - 3.1 Surveillance Function
  - 3.2 Correlation Function
  - 3.3 Entertainment Function
  - 3.4 Cultural Transmission
  - 3.5 Status Conferral/Conferment of Status
  - 3.6 Enforcement of Norms
  - 3.7 Dysfunctions of Mass Communication
- 4.0 Conclusion
- 5.0 Summary
- 6.0 Tutor-Marked Assignment
- 7.0 References/Further Readings

### **1.0 INTRODUCTION**

The function of mass communication in the society is enormous. This is evident in the different appellations or names the journalists are called. Names like watchdog, intellectual peeping toms, fourth estate of the realm and so on. The Press helps sanitise the society of all forms of corruption by scrutinizing the actions, policies, and performance of those who govern. The press, in its watchdog function, is the vital communicating link between the concerned citizen who wants to assess how those who are running things are doing and the evidence that can indicate the quality of their performance. The press checks the potential for inefficient, irresponsible, unethical, or even illegal behaviour on the part of those we trust as leaders. The importance of the press as the eyes and ears of the public in monitoring governmental activities has never been greater and its task has never been more difficult.

### **2.0 OBJECTIVES**

At the end of this unit, you should be able to:

- mention and explain the roles of mass communication in the society
- discuss why the Press is so useful and important in every society
- identify the perceived negative roles mass communication play in the society.

### 3.0 MAIN CONTENT

The functions and dysfunctions of mass communication are discussed in this unit under different subsections (3.1-3.7)

#### 3.1 Surveillance Function

This is otherwise known as news function of mass communication. It involves scouting the environment to bring the evidence essential for information [news] about major happenings in the society.

The word 'surveillance' connotes a careful monitoring of something done in secret. The idea behind surveillance is to protect things or someone under watch from falling below public expectation or going astray. This surveillance concept is synonymous to 'watchdog' role of the press. As a watchdog, the media monitors societal ills and exposes them. These ills include corruption in any sector of the society, politics, education, church, organisations etc.

By exposing corruption, the journalist is sanitizing the society and at the same time, putting public office holders on public scale which measurement is done by members of the public. By watchdog role, the journalist owes the public duty of digging out hidden deeds and untold/unheard dealings. For instance, it was the press that exposed the controversial award of ₦628 million for the renovation of the official quarters of the Nigeria first female Speaker of the Federal House of Representatives, Patricia Olubunmi Etteh and her deputy.

The surveillance or watchdog function of the press enables the mass media to beam their searchlight on the three arms of government, parastatals and the society at large. The surveillance function of the press is its basic responsibility. Any mass media worth its salt must constantly live up to its social responsibility role which is done through the watchdog approach.

Sambe (2005), in underscoring the surveillance function of the press on crime, cites cases:

*In 1986, two gangsters emerged from the crime scene in Nigeria, namely Lawrence Anini and Monday Osunbor. The press, in living up to its responsibility as surveillance for society, kept on beaming searchlight on the activities of the duo until they were arrested with some of their*

*collaborators, among them, an assistant superintendent of police, George Iyamu.*

The press also uncovered the involvement of the police in the Anini case. *This week* magazine puts it this way:

*From the evidence before the two tribunals, it was quite clear that the Anini saga would not have reached its frightening proportions but for the inherent conditions in the society. The police gave him information, sold him weapons and shared in his loot in perfect symbiosis.*

The surveillance role of the press in tracking down another notorious armed robber, Shina Rambo in 1992 was equally cited. The media described his identity, which turned out to be useful to the police in tracking him down. Rambo was described as a dare-devil kingpin, slim, dark and of average height, possessing two tribal marks one on each cheek characteristic of indigenes of Ondo town (Sambe 2005:42)

### **SELF ASSESSMENT EXERCISE 1**

Why is the surveillance function of the press regarded as fundamental to journalistic practice?

### **3.2 Correlation Function**

The correlation function of mass communication is otherwise known as the opinion or editorial function of the press. This refers to the process of editorial selection, interpretation and prescription through which the mass media help their consumers to better understand the information brought to them.

By the correlation function, the media provide the background social context and critical analyses necessary for that understanding. The press also helps to monitor public opinion, for example, through phone-in radio or television programmes.

The correlation function is best illustrated in columns and editorial pages of news papers where the columnist may compare statements made by political office holders with conflicting statements made by other politicians or personal views on a matter. It may also be observed in broadcast commentaries and editorials in television documentaries designed to make viewers aware of an issue or supportive of a prescribed course of action (Sambe 2005:44)

## SELF ASSESSMENT EXERCISE 2

As a trainee journalist, invoke the correlation function of the press to write an interpretative article on the aborted planned redenomination of the Naira by CBN. Your article must be suitable for publication in a National daily.

### 3.3 Entertainment Function

One of the most popular functions of mass communication is entertainment. As a matter of fact, higher percentage of audience prefers entertainment to information. Those in this category include students, youths, teenagers, sport lovers, kids (cartoons). Except for very serious minded individuals who tune the media for information, quite a number of people consume media products during their leisure time, and as such see media as a tool of enjoyment and entertainment.

By nature, entertainment is meant to ease tension and stress. It is synonymous to relaxation. Through home videos, film comedies, sports and cartoons, families can be glued to television for hours while catching their fun. Besides, viewers catch their fun through talk shows, advertisement (especially on Nollywood movies), live matches, television drama etc. The newspapers and magazines as well entertain through editorials and satirical cartoons. *Omoba* cartoon strip in *Punch* Newspaper is a good example. Just like the then popular *Josy Ajiboye* satirical cartoon of *Daily Times*.

In the contemporary world, pornographic magazines and newspapers are on the increase and their targeted audiences who are predominantly the youths are patronizing the print media products.

Of all the available media of mass communication, television as a broadcast medium is rated to be performing the entertainment function most; this is because it combines sound with sight. In other words, because it has audio-visual effect. For instance, a Nollywood video is better watched on TV screen than listened to on radio or read on the pages of newspapers or magazines. Television stations like *African Magic*, *Channel O*, are must watch stations for every audience interested in entertainment and relaxation. While *African Magic* strictly broadcast African movies and drama on a 24-hour basis, *Channel O* does nothing better than round the clock musicals.

The growing interest of the public in sports, especially football has necessitated an unprecedented increase in sport-biased newspapers and

magazines like *Soccer Star*, *Complete Football*, *Sports World* etc. Besides specialized newspapers on sports, back pages of most weekend national newspapers are dedicated to sports where vivid details about footballers and their teams are showcased for the entertaining pleasure of sports fans.

Apart from sport newspapers and magazines, there are other soft-sell media products that are more often than not, regarded as junk journalism or yellow journalism. They oftentimes engage in writing stories not well investigated. They carry ‘rumours’, sometimes ‘falsehood’ and half truths. Their primary aim is not to inform but to entertain. Examples are **Encomium**, **Fame**, **City People** etc.

Still on entertainment track, there are other specialized magazines on specific sector of the society, like education, fashion shows etc. For instance, *Across the Campus* and *STUDENTS TONIC* magazines focus on true life stories on campuses. Besides, the magazines showcase and celebrate uncommon faces on campuses-be it students, lecturers and administrators. These magazines have been the toast of the average Nigerian student because of the way the reality stories packaged in the magazines entertain them.

Magazines like **Ovation** are doing purely photo journalism. The magazine gained popularity for the way it captures pictures of people and events. **Ovation** no doubt is more for entertainment and relaxation than information.

Radio as a broadcast medium which lifeblood is sound is equally doing well in entertaining the public through programmes. For instance, radio drama, talk-back programmes, quiz, riddles and jokes and story telling (especially for children) are designed for relaxation and entertainment. Radio stations like Brilla FM were floated primarily to entertain people through sports.

We need to emphasize the entertainment inherent in what is regarded as the economic life wire of the broadcast media which is advertisement. Of a truth, most broadcast media houses cannot survive without advertisement. Nowadays, advertisers are spending heavily in the production of highly entertaining advert copies-most of them unbelievable. Advertisers in the soft drinks companies, beer producing companies and other manufacturing and product marketing companies pass across their commercial messages in a more entertaining way.

### **SELF ASSESSMENT EXERCISE 3**



1. Try and recollect the number of advert messages you have been exposed to in the television or radio, recall the way any ten of them entertain you.
2. Apart from the ones mentioned in this unit, mention ten other print media products that were floated primarily to entertain.

### **3.4 Cultural Transmission**

This function entails the passing on or the transfer of a nation's (or society) social heritage from one generation to another. Sambe (2005) describes the cultural transmission function as the preservation of past heritage or culture from one ethnic group to another, one nation to another and from generation to generation for the purpose of promoting and even integrating culture. Okunna (1994 cited in Sambe 2005) holds that the mass media disseminate cultural and artistic products for the purpose of preserving the past heritage of the people; they also help in the development of culture by awakening and stimulating the creative and aesthetic abilities in individuals, thus leading to the production of artifacts.

Mass media transmits culture by the way the programmes transmitted reflect the behavioural norms and standard practice in the society. If for instance, the contents of media messages emphasise morals and religious harmony as an acceptable way of survival in the society, then those who consume such contents are most likely to pattern their lives accordingly.

Another way of transmitting local culture is the programme policy of most broadcast media organizations such that 70% will be for local content and 30% for foreign content. For instance, Radio Lagos (*Tiwantinwa*) promotes and transmits Yoruba culture mostly.

This cultural transmission function brings us to examine the relationship between mass communication and culture.

#### **3.4.1 Mass Communication and Culture**

Culture defines our realities but communication constructs and maintains our culture. So it is in communication that cultural power resides. The mass media of communication are therefore very significant, leading to examination of the interaction between mass communication and culture.

Various thoughts have been put together on the power of the media and mass communication. We identify three related dichotomies of the debate on the power of the media in relation to culture.

### 1) **Micro versus Macro-Level of Effects**

The micro thought is that the media have relatively few direct effects at the personal level. The micro-level view is that the media have little impact because most people are not directly affected. The macro idea is that the impact of media operates at the cultural level. Media have a great impact because they influence the cultural climate.

### 2) **Administrative versus Critical Research**

Administration research asks questions about the immediate, observable influence of mass communication, critical research asks larger question about what kind of nation we are building, what kind of people we are becoming- would serve our culture better. While administrative concerns itself with direct causes and effects, critical research looks at larger, possibly more significant cultural questions.

### 3) **Transmissional versus Ritual Perspective**

Transmission school sees media as senders of information. The ritual perspective views media not as a means of transmitting “message in space” but as a central to “the maintenance of society in time”. Mass communication is not the act of imparting information but the representation of shared beliefs.

## 3.4.2 **What is Culture?**

Culture is the learned behaviour of members of a given social group. Harris says culture is the learned, socially acquired traditions and lifestyles of the members of a society, including their patterned, repetitive ways of thinking, feeling and activity. Geertz says culture is a historically transmitted pattern of meanings embodied in symbolic forms by means of which (people) communicate, perpetuate and develop their knowledge about and attitudes toward life. The definitions agree that culture is learned. The learning process is of course communication.

### **Functions and Effects of Culture**

Cultures help us categorise and classify our experiences; helps define us, our world and place in it. These result in a number of conflicting effects.

#### 1) **Limiting and Liberating Effects of Culture**

A culture's learned traditions and values can be seen as patterned, repetitive ways of thinking, feeling and acting. Culture limits our options and provides useful guidelines for behaviour. For example, when conversing, you do not consciously consider; "Now how far away should I stand?" You just stand where you stand. Culture provides information that helps us make meaningful distinctions about right and wrong, appropriate and inappropriate, good and bad, attractive and unattractive, and so on.

This happens through communication. Through a lifetime of communication, we have learned just what our culture expects of us. But culture's limiting effects can be negative, like when we are unwilling or unable to move past patterned, repetitive ways of thinking, feeling and acting, or when we entrust our "learning" to teachers whose interests are selfish, narrow, or otherwise not consistent with our own. E.g. US culture values thinner women (compare with Nigerians) What about Nigeria's culture of worshipping 'money' and that of corruption?

Culture can be liberating as well; because cultural values can be contested. Liberation from these limitations imposed by culture reside in our ability and willingness to learn and use patterned, repetitive ways of thinking, feeling, and acting, to challenge existing patterns; and so create our own.

## 2) **Defining, Differentiating, Dividing and Uniting Effects of Culture**

We are defined by our culture. As citizens of Nigeria, we are Nigerians, Africans, Yorubas, Igbos, Hausas etc. This label will conjure up stereotype and expectations in the minds of those who use and hear it. Culture also serves to differentiate us from others. Problem thus arises when this leads to division. Culture can divide us, but culture also unites us. Our culture represents our collective experience.

From the foregoing, we offer this definition of culture:

*Culture is the world made meaningful; it is socially constructed and maintained through communication. It limits as well as liberates us; it differentiates as well as unites us. It defines our realities and thereby shapes the way we think, feel and act. (Baran 2004)*

## **SELF ASSESSMENT EXERCISE 4**

With your limited knowledge of some broadcast media houses in Nigeria, give a brief assessment of how any ten of them perform the cultural transmission function.

### 3.5 Status Conferral

This function holds that the mass media confers higher status on individuals in the society through the frequency of reportage done on the individual. Whenever the press beams their reportage on an individual, he automatically acquires a status of public figure and the name of such individual becomes a household name. For instance, individuals like Lamidi Adedibu, Chris Uba, Chris Ngige, Ayodele Fayose, Gani Fawehimi, Wole Soyinka, etc became household names in Nigeria because of the high level of frequency of reportage given to them by the mass media.

The status conferment concept is coined by Lazarsfield and Merton who posit that the more someone is featured in the media, the more one's status is raised to prominence. The duo also wrote that mass media audiences apparently subscribe to a secular belief that if you really matter, you will be a focus of mass attention and if you are a focus of mass attention then you surely must matter.

Apart from individuals who get higher status by virtue of the prominence given to them by the mass media, media men and women especially those who appear on screen - the newscasters, reporters, hosts and hostesses of shows / programmes get themselves into public fame by virtue of their work. People get to see them every time and then make them their models. Abike Dabiri, a newscaster in NTA who was elected as member of the Nigerian House of Representatives, built on the fame she made as a broadcaster. During her electioneering campaign, people whom she never knew just called her and made financial donations to her campaign team. Other broadcasters- turned celebrities are role models for others. Besides, actors and actresses in home videos are becoming celebrities because of their frequency in film acting and shows.

It must be pointed out however, that the weight of status conferred on individuals by the medium is a function of the social status or rating of such medium of mass communication. In other words, the higher the rating of mass medium in public eye, the higher the status conferred on such individual. Someone who was shot into prominence by the western media, say CNN or BBC will have higher status than someone with a national or local TV like NTA or Galaxy TV. In the same vein, someone who was brought into fame by *Ebony* magazine or *Wall Street Journal*

will assume higher status than someone who was read in *Genevieve* magazine or *Nigerian Tribune* newspaper.

### **SELF ASSESSMENT EXERCISE 5**

Mention ten Nigerians who were shot into prominence by the mass media. Give reasons for your cases and note that you are not permitted to repeat any of the cases already cited in this section.

### **3.6 Enforcement of Norms and Cultural Values**

The mass media enforce the basic norms and values of the society through their reportage of cultural issues and events. It is through the media that people get to know how cultural festivals are being celebrated, how people dance and sing in the traditional way. These cultural products are exhibited through Television (documentary, news coverage); radio (folklore, storytelling); magazines and newspapers (pictures, write-up/ features).

This function of the media was underscored by MacBride (1980) when he said that the media promote the dissemination of cultural and artistic products for the purpose of preserving the heritage of the past, as well as the development of culture by widening the individual's horizon, awakening his imagination and stimulating his aesthetic needs, values and creativity.

Akpan (1987) corroborates the enforcement of cultural values function of the media when he states that the transaction of social heritage from one generation to the next involves shaping of values, notions, traditions, customs etc and passing them on from generations to generations. Also adding his weight is Emenyeonu (1992) when he supports the notion that through their coverage, the mass media help to promote heterogeneous cultural groups, thereby correcting any misconceptions and building a sense of pride in the citizens.

Succinctly, the mass media help a great deal to interpret, define, analyse issues that border on peoples cultures (both past and present). The media through entertaining and educating programmes set agenda for the public as regard which cultural values they should accept or reject. They can also make citizens appreciate their indigenous values, norms, and cultural practices and embrace them. The norms of a society are almost always higher than the personal practices of the individuals within the society. For example, we publicly condemn what we privately condone.

Public officers are less likely to succumb to temptation when they know that contemplated trespasses might be discovered by the mass media. Corporations become concerned about the ethics of their business practice when they know that these practices will be observed by their stakeholders, regulatory agencies and the general public. Contributors towards charity tend to be more generous when they know that the amount of their contributions will be published and that peer approval or disapproval will follow (Sambe 2005: 67).

### **SELF ASSESSMENT EXERCISE 6**

How would you assess the cultural content of programmes disseminated by NTA? Would you advocate a ban in the dissemination of foreign programmes? Give two reasons for your answer.

### **3.7 Negative Functions of Mass Communication**

Although this unit focuses more on the positive functions of mass communication, meaning that mass communication performs more positive functions than negative ones, however attempt must be made to highlight the negative role mass communication plays in the society.

Two negative roles of mass communication in the society is the propagation of violence and pornography. Researchers have proved that these two have caused negative behavioural tendencies and institute false values in the minds of the people especially children. More often than not, children who are exposed, to violent act in films and on television tend to act violently in their day-to-day affairs. In Nigeria, the exposure of school children to *James Bond* films and other related violent media products have made the children behave violently. In schools children take on their fellow students in fight similar to what they have watched in *Bruce Lee* and *Hulk Hogan*'s on television.

Bittner (1951) corroborates

*There is a convergence of the fairly substantial experimental evidence for short-run causation of aggression among some children by viewing violence on the screen, and the much less certain evidence from field studies that extensive violence viewing precedes on the long-run manifestations of aggressive behaviour. Children in formation years therefore, view violence as an accepted way of life and can grow up to engage in it.*

Apart from violence, the mass media are used to expose people to illicit sex. Through *blue* films or *adult* films, the mass media corrupt the moral sanctity of the youths by increasing their desire to have sex even at a tender age. What is more worrisome is the growing number of websites devoted to sexual activities where people could watch sex films and pornographic pictures at a near zero cost. These websites recorded highest hit recently as school children beseech cyber café to access their sites.

Other dysfunctions of the mass media are: cultural imperialism, and invasion of individual privacy.

### **SELF ASSESSMENT EXERCISE 7**

Write a two-page article to assess the functions of mass communication, show in your write-up whether the negative functions outweigh the positive ones or vice versa.

## **4.0 CONCLUSION**

It is appropriate to conclude that the surveillance function of mass communication is very vital and fundamental to the survival of every society of man. It is regarded as the most crucial among other functions of mass communication. Every journalist worth his salt must strive at all times to survey his society with a view to uncovering the ills and corruption in the society.

One needs to point out that many other functions of mass communication are closely related to each other, in that, one cannot be discussed in isolation of others.

## **5.0 SUMMARY**

We have been able to underscore the importance of the functions of the press in any society. We also pointed out that every journalist must be able to perform these roles adequately without any fear or favour because by virtue of the oath of objectivity they swore to as journalists; they owe the society the reportage needed to uncover the ills in the society with a view to righting the wrongs.

The media provides essential information (news) on development projects, political activities, sports, judicial reports, violence, instability etc. The media provides warnings on dangers and threat to national stability-on war, rebellion, natural disasters, with suggestions on how to avert such occurrences.

The unit reiterated that, through its functions, the media also bring human interest stories – drawing people’s attention to the oddities and fun of human condition. Besides, the press owes the public the duty of interpreting issues being reported so that the readers can better understand the information brought to them.

One needs to recap that the functions of mass communication which are surveillance; correlation; entertainment; culture transmission; status conferral and enforcement of norms and values must be constantly performed by the mass media for the betterment of the society.

## **6.0 TUTOR-MARKED ASSIGNMENT**

Write a two- page essay on the role of media in sustainable democracy

## **7.0 REFERENCES/FURTHER READINGS**

Baran, S.J. (2002). *Introduction to Mass Communication*. New York: MacGraw Hill.

Bitner, R. (1989). *Mass Communication: An Introduction*. New Jersey: Prentice Hall.

Sambe, J.A.(2005). *Introduction to Mass Communication Practice in Nigeria*. Ibadan: Spectrum Books Limited.



## **MODULE 2      FORMS      AND      CONTEXT      OF COMMUNICATION**

Unit 1	Verbal Communication
Unit 2	Non-Verbal Communication
Unit 3	Intra and Interpersonal Communication
Unit 4	Group and Public Communication
Unit 5	Cross Culture/International Communication

### **UNIT 1    VERBAL COMMUNICATION**

#### **CONTENTS**

1.0	Introduction
2.0	Objectives
3.0	Main Content
	3.1    Oral Communication
	3.2    Written Communication
4.0	Conclusion
5.0	Summary
6.0	Tutor-Marked Assignment
7.0	References/Further Readings

#### **1.0    INTRODUCTION**

This unit examines the two major components of Verbal communication. They are:

1. Oral (speech) communication and;
2. Written communication

#### **2.0    OBJECTIVES**

At the end of this unit, you should be able to:

- understand what verbal communication is and what it is not
- understand the advantages and disadvantages of written communication
- understand the advantages and disadvantages of oral communication.

### **3.0 MAIN CONTENT**

There are basically two forms of communication- verbal and non-verbal communication. Also, there are two major components of verbal communication. They are:

1. Oral (speech) communication and;
2. Written communication

#### **3.1 Oral Communication**

Succintly, oral communication - means communication by word of mouth. This is the primary form of human communication. Speaking is natural and consequently, every child with no physical problem normally acquires the speech form used around him. It is the use of spoken language that gave humans a great advantage over the animals.

Many civilizations thrived basically on oral communication before the advent of writing. Even today, there are still many ethnic groups and tribes whose languages have not been reduced to writing. Oral communication is the most commonly used of the various forms of communication, and it pervades all strata of every society.

#### **Types of Oral communication**

The Free Dictionary defines oral communication as follows:

1. Speech communication, spoken communication, spoken language, voice communication, language, speech language, linguistic communication jointly define as a systematic means of communicating by the use of sounds or conventional symbols.
2. Auditory communication - communication that relies on hearing.
3. Orthoepy, pronunciation - the way a word or a language is customarily spoken; "the pronunciation of Chinese is difficult for foreigners"; "that is the correct pronunciation".
4. Conversation - the use of speech for informal exchange of views or ideas or information etc.

5. Discussion - an exchange of views on some topic; "we had a good discussion"; "we had a word or two about it".
6. Locution, saying, expression - a word or phrase that particular people use in particular situations; "pardon the expression".
7. Non-standard speech - speech that differs from the usually accepted, easily recognizable speech of native adult members of a speech community.
8. Idiolect - the language or speech of one individual at a particular period in life.
9. Monologue - a long utterance by one person (especially one that prevents others from participating in the conversation).
10. Magic spell, magical spell, charm, spell - a verbal formula believed to have magical force; "he whispered a spell as he moved his hands"; "inscribed around its base is a charm in Balinese"
11. Dictation - speech intended for reproduction in writing.
12. Monologue, soliloquy - speech you make to yourself

### **Advantages of Oral Communication**

1. It is a learnable and improvable human activity.
2. It is a more accurate reflection of thought and attitude of the speaker.
3. It creates and sustains warm, interpersonal relationships.
4. It combines sight and sound, thus enabling participants to benefit from both verbal and non-verbal stimulus.
5. It can satisfy man's needs and desires (wants) more quickly than writing or gestures.
6. It allows for instantaneous exchange of ideas, information, opinions, feelings and attitudes.
7. It enables participants to seek immediate clarification whenever in doubt of the meaning being negotiated.
8. It provides for instantaneous feedback, thereby making it possible for the participants to assess the success, or failure, of their

communication efforts and so decide whether or not to modify their needs of communication interaction.

### **Disadvantages of Oral Communication**

1. It lacks permanence.
2. It does not allow participants' thought to crystallise, thus resulting in imprecise communication and even outright errors which could be avoided in written communication.
3. There is possibility of distortion of meaning.
4. It can easily be denied.
5. It has little weight as contractual evidence.
6. It is usually not admissible in evidence in the law court.

### **SELF ASSESSMENT EXERCISE 1**

The engagement of mouth and tongue is very crucial to oral communication. Discuss

### **3.2 Written Communication**

Written Communication could be simply defined as communication by means of written symbols (either printed or handwritten). Writing as a system of communication is an offshoot of speech; that is, we have the spoken language before writing. While speech is natural, writing has to be taught and learnt accordingly. Besides, there is no language that exists in written form without a spoken form.

#### **Types of Written Communication**

1. Black and white, written language communication - something that is communicated by or to or between people or groups.
2. Folio, leaf - a sheet of any written or printed material (especially in a manuscript or book)
3. Transcription, written text - something written, especially copied from one medium to another, as a typewritten version of dictation.

4. Writing - letters or symbols that are written or imprinted on a surface to represent the sounds or words of a language; "he turned the paper over so the writing wouldn't show"; "the doctor's writing was illegible"
5. Piece of writing, written material, writing - the work of a writer; anything expressed in letters of the alphabet (especially when considered from the point of view of style and effect); "the writing in her novels is excellent"; "that editorial was a fine piece of writing"
6. Writings - (usually plural) the collected work of an author; "the idea occurs with increasing frequency in Hemingway's writings".
7. Prescription - written instructions from a physician or dentist to a druggist concerning the form and dosage of a drug to be issued to a given patient.
8. Prescription - written instructions for an optician on the lenses for a given person.
9. Reading material, reading - written material intended to be read; "the teacher assigned new readings"; "he bought some reading material at the airport".
10. Correspondence - communication by the exchange of letters
11. Code, codification - a set of rules or principles or laws (especially written ones)
12. Print - the text appearing in a book, newspaper, or other printed publication; "I want to see it in print"

### **Advantages of Written Communication**

1. It provides opportunities for record keeping.
2. It is amenable to conveying complex messages, information, and ideals as well as explaining difficult process.
3. It can be reproduced through various reprographic processes and dispatched to widely scattered receivers.
4. It provides avenues through which oral transaction can be clarified, analysed and confirmed.
5. It provides a basis for contractual agreements.

6. It reduces the chance of distortion.

### **Disadvantages of Written Communication**

- (1) It may require a laborious effort to produce.
- (2) It lacks the warmth of interpersonal relationships.
- (3) It may be expensive especially when it requires being dispatched to scattered receivers.
- (4) It delays feedback.
- (5) It makes it difficult for the sender to modify his message once it is composed and dispatched.
- (6) It multiplies errors, particularly with the advances in the technology of message dissemination through computer networks, fax, e-mail etc.
- (7) It requires a good level of literacy on the part of the receiver.

### **SELF ASSESSMENT EXERCISE 2**

Compare and contrast the weaknesses and strength of oral and written communication.

## **4.0 CONCLUSION**

One major description of verbal communication is that it requires the use of words, vocabulary, numbers and symbols and is organized in sentences using language. Mastering linguistic skill is not reserved for the selected few but is a skill that each and every one should develop to improve relationships and interactions.

Everyone's brain is forever having thoughts and they are primarily with words. Words spoken, listened to or written affect your life as well as others. They have the power to create emotions and move people to take action. When verbal communication is delivered accurately and clearly, you activate the mind and encourage creativity.

You create your reality with your senses, the eyes, ears and feelings and words and symbols are used to create the meanings. This is why you are encouraged to read and watch informative materials, listen to

motivational audio programs and attend classes or seminars that relate to your line of work or objectives. Positive and uplifting spoken or written messages motivate and inspire.

## **5.0 SUMMARY**

The unit has been able to discuss in appreciable details what verbal communication is all about. It examined the major components of verbal communication which are oral and written communication, as well as underscoring their advantages and disadvantages. The following types of oral communication are listed: Speech communication, spoken communication, spoken language, voice communication, language, speech language, linguistic communication, Auditory communication, Orthoepy, Pronunciation, Conversation, Discussion, Locution, saying, expression, Non-standard speech, Idiolect, Monologue, Magic Spell, Charm, Spell, Dictation and Monologue, Soliloquy

## **6.0 TUTOR–MARKED ASSIGNMENT**

Write a two-page essay on the concept of *oral media*

## **7.0 REFERENCES/FURTHER READINGS**

Baran, S.J. (2002). *Introduction to Mass Communication*. New York: McGraw Hill.

Bitner, R. (1989). *Mass Communication: An Introduction*. New Jersey: Prentice Hall.

Sambe J.A (2005). *Introduction to Mass Communication Practice in Nigeria*. Ibadan: Spectrum Books Limited.

## **UNIT 2 NON-VERBAL COMMUNICATION**

### **CONTENTS**

- 1.0 Introduction
- 2.0 Objectives
- 3.0 Main Content
  - 3.1 Characteristics and Functions of Non-Verbal Communication
  - 3.2 Types of Non-Verbal Communication
  - 3.3 Other Channels of Non-Verbal Communication
  - 3.4 Differences between Verbal and Non-Verbal Communication
- 4.0 Conclusion
- 5.0 Summary
- 6.0 Tutor-Marked Assignment
- 7.0 References/Further Readings

### **1.0 INTRODUCTION**

This unit gives a detailed description of non-verbal communication. It examines the three major components of Non-Verbal communication in terms of:

1. The Characteristics and Functions of Non-Verbal Communication
2. Types of Non-Verbal Communication and;
3. The basic differences between Verbal and Non-Verbal Communication

### **2.0 OBJECTIVES**

At the end of this unit, you should be able to:

- understand the Characteristics and Functions of Non-Verbal Communication
- explain and identify types of Non-Verbal Communication
- understand the basic differences between Verbal and Non-Verbal Communication.

### **3.0 MAIN CONTENT**



## **What is Non-verbal communication?**

Non-verbal communication is any information that is communicated without using words. It is often referred to as “untalk communication or silent language”. Non-verbal communication is a powerful arsenal in the face-to-face communication encounters, expressed consciously in the presence of others and perceived either consciously or unconsciously. Much of non-verbal communication is unintentional- people are not even aware that they are sending messages.

### **3.1 Characteristics of Non-Verbal Communication**

#### **1. Non-Verbal Communication is Culturally Determined**

Non-verbal communication is learnt in childhood, passed on to you by your parents and others with whom you associate. Through this process of growing up in a particular society, you adopt the traits and mannerisms of your cultural group.

#### **2. Non-Verbal Message May Conflict With Verbal Message**

Non-verbal communication is so deeply rooted, so unconscious, that you can express a verbal message and then directly contradict it with a non-verbal message.

#### **3. Non-Verbal Message are Largely Unconscious**

Non verbal communication is unconscious in the sense that it is usually not planned nor rehearsed. It comes almost instantaneously.

#### **4. Non-Verbal Communication Shows Your Feelings and Attitudes**

Facial expressions, gestures, body movements, the way you use your eyes- all communicate your feelings and emotions to others.

##### **3.1.1 Functions of Non-Verbal Communication**

1. **Complementing:** Non-verbal cues complement a verbal message by adding to its meaning. You can pat someone you offended at the back as you say sorry to him or her.
2. **Regulating:** To regulate verbal communication. E.g. Kicking the car while still talking with someone outside shows you are ready to go.

3. Substituting: Can substitute for verbal message. Waving hands at someone instead of saying goodbye.
4. Accenting: Can be used to accent, emphasise or reinforce what you're saying.

### **SELF ASSESSMENT EXERCISE 1**

How functional is non-verbal communication to man?

## **3.2 Types of Non-verbal Communication**

### **1. Vocalics (Paralanguage)**

This deals with the extra-linguistic aspects of communication. It concerns voice rather than words. E.g. Yawning to indicate tiredness or boredom; belching after food or drink to show one has eaten to his fill.

Paralanguage also include such vocal characteristics as rate (speed of speaking), pitch (highness or lowness of tone), volume (loudness) and quality (pleasing or unpleasant sound). Any or all of these added to words, modify meaning.

### **2. Kinesics (Body Language)**

1. Emblems are body movements that directly translate into words e.g. holding your fingers to show how many of something you want.
2. Illustrators: they accent, emphasise or reinforce words e.g. pointing down the road with finger when giving direction to someone.
3. Regulators: control the back-and-forth flow of speaking and listening. e.g. when a teacher points at the student who should speak next in the class.
4. Displays of feelings: show through facial expressions and body movements, how intensely a person is feeling.
5. Adaptors: are used to adjust to communication situation. They vary and are specific to each person's own needs and the communication situation. These make them difficult to classify or describe generally. For example you have rented an apartment, and your mother comes to visit you. While she is there, she spends time moving objects and furniture around. This may mean that you are not very tidy. On another level, she may be saying you are still her child and that she, your mother, is still in charge.

### 3. Oculistics (Eye Language)

Messages are conveyed through the eyes by way of contact, blinks, eye movement and pupil dilation.

The eye is used to:

1. give the “greenlight” or declare the communication channel open.
2. seek and provide reaction in form of feedback
3. signal the intention to be involved or included in a discussion.
4. gaze at, or probe into, and provoke anxiety in others.
5. indicate disavowal of all social contacts and “put others off”
6. show excitement at getting a gift you want.

### SELF ASSESSMENT EXERCISE 2

Describe the type of non-verbal communication you normally use.

### 3.3 Other Channels of Non-Verbal Communication

#### The Human Body

Through human body, some kinds of communication can take place. This is done through inscription and drawing of symbols on human flesh. The inscription which has symbolic meaning could be in terms of tattoos, brands, piercing, and scarifications. In Nigerian campuses, members of secret cults use this kind of non-verbal communication to speak to themselves.

In Western societies, at least, there appears to be widespread dissatisfaction with one's own body. Plastic surgeons cater to this discontent. In the U.S. alone, there are an estimated 750,000 cosmetic surgery procedures annually. The most frequent cosmetic procedures for women are (in order): liposuction, breast augmentation and collagen injections. For men, the most common procedures are nose reshaping, eyelid surgery, and liposuction.

Where do images of the "perfect" body come from? During the last century, the image of bodily perfection in Western nations has grown progressively thinner. This seems particularly true for women. Current female models are tall, extremely thin, and also large-breasted--and this combination is so rare as to be nearly impossible for most women.

Long after prejudice about religious, ethnic, and racial groups has become socially unacceptable, the overweight are still openly ridiculed and insulted. It may be that "weightism" is the last socially acceptable

prejudice. There are people who have experienced cruelty and humiliation solely because of their size. These public embarrassments are common for larger people and the pain is unforgettable.

Human bodies carry enormous significance--for others, and also for ourselves. Preferences and prejudices about the body can lead us to attempt dramatic--but not always wise--alterations of what we look like. Images of the "ideal" body vary dramatically across cultures, and also over time. This means that current images of the "ideal body" reflect arbitrary preferences--and not universal, timeless standards of beauty.

### **Human Face**

The face is one of the most powerful channels of nonverbal communication. Large number of messages and cues can be 'read' from this powerful channel of human communication. Topics include the difference between true emotions and acted emotions; how the face serves as an important 'identity document;' how pupil size affects attractiveness; facial cues that police departments use for detecting drug or substance abuse; dynamic changes in the face as it ages; plastic surgery and other modifications of the face to enhance its attractiveness; cultural differences in beauty standards; the significance of changes in hair length and style; and important mythology about the face over the centuries.

### **Human Voice**

Human voice are said to be 'beautiful', 'attractive' and 'sweet'. Geographic clues are only one of many messages contained in our voices. Our vocal paralinguistics consists of all cues other than the text of the words we use. Everything else is vocal paralinguistics and this includes a very large number of potentially important clues: pronunciation, national accent, regional accent, fluency or dysfluency, standard or non-standard speech, whether the language we speak was our native tongue, emotion, charisma, indications of our relationship with the listener, sarcasm, deference, contempt, truth or deception, etc. Human voice communicates important clues about who we are and what we feel - and these clues slip out whether we want them to or not. Vocal paralinguistics is extremely subtle, but the clues in our voices are clear and legible. This makes vocal paralinguistics one of the most powerful 'channels' of nonverbal communication.

### **Gesture**

Gesture means a lot in communication. The unfortunate thing is that what a gesture means in one culture is different from its meaning in

other culture. In other words, there are international differences in gestures, and cultural differences in nonverbal communication generally. There are angry gestures, obscene gestures, friendly gestures, warning gestures, gang gestures, secret gestures, and embarrassing gestures.

Below are several fascinating questions about gestures and nonverbal communication that need to be answered before one could have a good understanding of gesture:

1. Is there a 'universal language' of gestures?
2. At what age do children first learn about gestures, and when do they become fluent at performing them?
3. Do all cultures have at least one obscene gesture?
4. Does the same gesture have radically different meanings in different cultures?
5. Can gestures serve as secret messages or as signals of group membership?
6. Do some cultures have a unique category of gestures-one that expresses an idea found in no other society?

### **SELF ASSESSMENT EXERCISE 3**

How does the human body communicate?

### **3.4 Differences between Verbal and Non-Verbal Communication**

Hybels and Weaver II (2001) identify eight important ways in which verbal and non-verbal communications differ:

#### **Environment**

In contrast to verbal communication, non-verbal communication can take place when you are not around for people to form an impression of you directly e.g. the room you live in, poster on your walls, where you eat, etc.

#### **Continuity**

Verbal communication begins and ends with words, non-verbal continues.

#### **Channel**

Non-verbal communication often uses more than one channel- can combine sound and sight.

### **Feedback**

Non-verbal communication gives a lot of feedback.

### **Control**

While you can control verbal communication, you do not always have control over non-verbal communication especially emotional responses.

### **Senses**

Verbal communication uses words, while non-verbal communication uses senses- sense of taste, touch, sight, smell.

### **Structure**

Non-verbal communication does not follow a planned sequence because much of it occurs unconsciously. For example, you do not plan to cross your legs when you are speaking with someone. Unlike verbal communication which has a grammar that determines how you build your sentences, nonverbal communication lacks formal structure.

### **Acquisition**

Many verbal communication rules are taught in formal environment. Much of non-verbal is not taught; you pick them up imitating others.

## **SELF ASSESSMENT EXERCISE 4**

In one sentence, differentiate between Verbal communication and Non-verbal communication

## **4.0 CONCLUSION**

It must be stressed that sign languages and writing are not classified as nonverbal communication because they make use of words. Verbal communication is that which concerns the use of words and as such, "verbal communication" cannot be used as a synonym for oral or spoken communication. Nonverbal communication is usually understood as the

process of communication through sending and receiving wordless messages. Such messages can be communicated through gesture; body language or posture; facial expression and eye contact; object communication such as clothing, hairstyles or even architecture; symbols and infographics; prosodic features of speech such as intonation and stress and other paralinguistic features of speech such as voice quality, emotion and speaking style.

## **5.0 SUMMARY**

The unit has attempted to discuss non verbal communication by emphasizing the fact that writing and sign language do not belong to non verbal communication but verbal communication. It emphasized that nonverbal communication can occur through any sensory channel — sight, sound, smell, touch or taste. The unit also examined the types of nonverbal communication which include Vocalics (Paralanguage), Kinesics (Body Language), Oculistics (Eye Language).

According to the unit, the characteristics of non-verbal communication include culturally determined, Non-verbal message may conflict with verbal message, Non-verbal Message are largely unconscious, Non-verbal communication shows your feelings and attitudes.

Differences between verbal and non verbal communication could be understood in terms of Environment, Continuity, Channel, Feedback, Control, Senses, Structure and Acquisition

## **6.0 TUTOR–MARKED ASSIGNMENT**

Sign language and writing are not oral communication since they do not require mouth and tongue, yet they are said to be non verbal form of communication. Discuss

## **7.0 REFERENCES/FURTHER READINGS**

Burgoon, J. K., Buller, D. B., & Woodall, W. G. (1996). *Nonverbal Communication: The Unspoken Dialogue* (2nd ed.), New York: McGraw-Hill.

Guerrero, L. K., DeVito, J. A., Hecht, M. L. (Eds.)(1999). *The Nonverbal Communication Reader*. (2nd ed.), Lone Grove, Illinois: Waveland Press.



## **UNIT 3    INTRA-PERSONAL    AND    INTERPERSONAL COMMUNICATION**

### **CONTENTS**

- 1.0 Introduction
- 2.0 Objectives
- 3.0 Main Content
  - 3.1 Intra-Personal Communication
  - 3.2 Inter-Personal Communication
  - 3.3 Inter-Personal Communication and Relationship
- 4.0 Conclusion
- 5.0 Summary
- 6.0 Tutor–Marked Assignment
- 7.0 References/Further Readings

### **1.0 INTRODUCTION**

This unit examines the features of intrapersonal communication. This is done under the following subtitles:

1. Definition of intrapersonal communication;
2. Various kinds of intrapersonal communication;
3. Definitions and concept of interpersonal communication
4. The place of relationship in interpersonal communication

### **2.0 OBJECTIVES**

At the end of this unit, you should be able to:

- explain the concept of intrapersonal communication
- identify and describe the various kinds of interpersonal communication
- explain what the concept of interpersonal communication is and what it is not
- explain the place of relationship in interpersonal communication.

### **3.0 MAIN CONTENT**

#### **Contexts of Communication**

Contexts here mean the different levels at which communication occurs. It can also be referred to as the kinds of communication that are available. Under context of communication, we have the following:

- I. Intra-personal and Interpersonal Communication

- II. Group Communication
- III. Public Communication
- IV. Mass Communication

### **3.1 Intra-Personal Communication**

This is essentially a neuro-physiological activity which involves some mental interviews for the purposes of information processing and decision making. The basic operations of intrapersonal communication are to convert raw data from environment to information; to interpret and give meaning to that information and to use such meaning. In other words, it is communication that occurs within you.

Because intrapersonal communication is centered in the self, you are the sender and the receiver. The message is made up of your thoughts and feelings and the channel is your brain, which processes what you are thinking and feeling. There is also feedback because you talk to yourself, you discard certain ideals and replace them with others.

Intrapersonal communication is language use or thought internal to the communicator. Intrapersonal communication is the active internal involvement of the individual in symbolic processing of messages. The individual becomes his or her own sender and receiver, providing feedback to him or herself in an ongoing internal process. It can be useful to envision intrapersonal communication occurring in the mind of the individual in a model which contains a sender, receiver, and feedback loop.

Although successful communication is generally defined as being between two or more individuals, issues concerning the useful nature of communicating with oneself and problems concerning communication with non-sentient entities such as computers have made some argue that this definition is too narrow.

#### **Kinds of Intrapersonal Communication**

Below are the different kinds of intrapersonal communication:

- Writing (by hand, or with a word processor, etc.) one's thoughts or observations: the additional activities, on top of thinking, of writing and reading back may again increase self-understanding ("How do I know what I mean until I see what I say?") and concentration. It aids ordering one's thoughts; in addition it produces a record that can be used later again. Copying text to aid memorizing also falls in this category.

- Making gestures while thinking: the additional activity, on top of thinking, of body motions, may again increase concentration, assist in problem solving, and assist memory.
- Sense-making e.g. interpreting maps, texts, signs, and symbols
- Interpreting non-verbal communication e.g. gestures, eye contact
- Communication between body parts; e.g. "My stomach is telling me it's time for lunch."
- Day-dreaming
- Nocturnal dreaming, including and especially lucid dreaming
- Speaking aloud (*talking to oneself*), reading aloud, repeating what one hears; the additional activities of speaking and hearing (in the third case of hearing again) what one thinks, reads or hears may increase concentration and retention. This is considered normal, and the extent to which it occurs varies from person to person. The time when there should be concern is when *talking to oneself* occurs outside of socially acceptable situations.

### SELF ASSESSMENT EXERCISE 1

Intrapersonal communication is more than just thinking. Intrapersonal communication is how one communicates with oneself. It includes the concepts of inner speech. Explain.

### 3.2 Interpersonal Communication

**Interpersonal Communication** occurs when you communicate on a one-to-one basis usually in an informal, unstructured setting. It occurs mostly between two people, though it may include more than two. Each participant functions as a sender-receiver; their messages consist of both verbal and non-verbal symbols and the channels used mostly are sight and sound. It also offers the greatest opportunity for feedback.

To better understand the concept of interpersonal communication, one needs to compare it to other forms of communication. In so doing, one would examine how many people are involved, how physically close they are to one another, how many sensory channels are used, and the feedback provided. Interpersonal communication differs from other forms of communication in that there are few participants involved, the interactants are in close physical proximity to each other, there are many sensory channels used, and feedback is immediate.

Another way to understand the concept of intrapersonal communication is through the developmental view. From this view, interpersonal communication is defined as communication that occurs between people who have known each other for some time. Importantly, these people

view each other as unique individuals, not as people who are simply acting out social situations.

### 3.2.1 Functions of Interpersonal Communication

Interpersonal communication is desirable for many reasons.

#### To Gain Information

People engage in interpersonal communication to gain knowledge about another individual. Social Penetration Theory says that we attempt to gain information about others so that we can interact with them more effectively. We can better predict how they will think, feel, and act if we know who they are. We gain this information passively, by observing them; actively, by having others engage them; or interactively, by engaging them ourselves. Self-disclosure is often used to get information from another person.

#### To Build a Context of Understanding

Another reason why people engage in interpersonal communication is to help them better understand what someone says in a given context. The words we say can mean very different things depending on how they are said or in what context. **Content Messages** refer to the surface level meaning of a message. **Relationship Messages** refer to how a message is said. The two are sent simultaneously, but each affects the meaning assigned to the communication. Interpersonal communication helps us understand each other better.

#### To Establish Identity

Another reason we engage in interpersonal communication is to establish an identity. The **roles** we play in our relationships help us establish identity. So too does the **face**, the public self-image we present to others. Both roles and face are constructed based on how we interact with others.

#### Interpersonal Needs

Finally, we engage in interpersonal communication because we need to express and receive interpersonal needs. William Schutz has identified three such needs: inclusion, control, and affection.

- Inclusion is the need to establish identity with others.
- Control is the need to exercise leadership and prove one's abilities. Groups provide outlets for this need. Some individuals do not want

to be a leader. For them, groups provide the necessary control over aspects of their lives.

- Affection is the need to develop relationships with people. Groups are an excellent way to make friends and establish relationships.

### **3.2.2 Principles of Interpersonal Communication**

Donnel King (2000) identifies four major principles that underlie the workings of interpersonal communication in real life and which cannot be ignored. They are described below:

#### **Interpersonal Communication is Inescapable**

The truth is that we can't but communicate. The very attempt not to communicate communicates something. Through not only words, but through tone of voice and through gesture, posture, facial expression, etc., we constantly communicate to those around us. Through these channels, we constantly receive communication from others. Even when you sleep, you communicate. Remember a basic principle of communication in general: people are not mind readers. Another way to put this is: people judge you by your behaviour, not your intent.

#### **Interpersonal Communication is Irreversible**

Interpersonal communication is one way. You can't really take back something once it has been said. The effect must inevitably remain. Despite the instructions from a judge to a jury to "disregard that last statement the witness made," the lawyer knows that it can't help but make an impression on the jury. A Russian proverb says, "Once a word goes out of your mouth, you can never swallow it again."

#### **Interpersonal Communication is Complicated**

No form of communication is simple. Because of the number of variables involved, even simple requests are extremely complex. Theorists note that whenever we communicate there are really at least six "people" involved: (1) who you think you are; (2) who you think the other person is; (3) who you think the other person thinks you are; (4) who the other person thinks /she is; (5) who the other person thinks you are; and (6) who the other person thinks you think s/he is.

We don't actually swap ideas, we swap symbols that stand for ideas. This also complicates communication. Words (symbols) do not have inherent meaning; we simply use them in certain ways, and no two people use the same word exactly alike.

Osmo Wiio gives us some communication maxims similar to Murphy's law (Osmo Wiio, *Wiio's Laws--and Some Others* (Espoo, Finland: Welin-Goos, 1978) :

- If communication can fail, it will.
- If a message can be understood in different ways, it will be understood in just that way which does the most harm.
- There is always somebody who knows better than you what you meant by your message.
- The more communication there is, the more difficult it is for communication to succeed.

These tongue-in-cheek maxims are not real principles; they simply humorously remind us of the difficulty of accurate communication.

### **Interpersonal Communication is Contextual**

In other words, communication does not happen in isolation. There is:

1. *Psychological context*, which is who you are and what you bring to the interaction. Your needs, desires, values, personality, etc., all form the psychological context. ("You" here refers to both participants in the interaction.)
2. *Relational context*, which concerns your reactions to the other person--the "mix."
3. *Situational context* deals with the psycho-social "where" in which you are communicating. An interaction that takes place in a classroom will be very different from one that takes place in a bar.
4. *Environmental context* deals with the physical "where" in which you are communicating. Furniture, location, noise level, temperature, season, time of day, all are examples of factors in the environmental context.
5. *Cultural context* includes all the learned behaviors and rules that affect the interaction. If you come from a culture (foreign or within your own country) where it is considered rude to make long, direct eye contact, you will out of politeness avoid eye contact. If the other person comes from a culture where long, direct eye contact signals trustworthiness, then we have in the cultural context a basis for misunderstanding.

### 3.2.3 Types of Interpersonal Communication

Interpersonal communication has three major types. They include:

1. Dyadic communication,
2. Public speaking, and
3. Small-group communication.

#### DYADIC COMMUNICATION

Dyadic communication is simply a method of communication that only involves two people such as a telephone conversation or even a set of letters sent to and received from a pen pal. In this communication process, the sender can immediately receive and evaluate feedback from the receiver. So that, it allows for more specific tailoring of the message and more personal communication than do many of the other media.

### 3.2.4 Basic Elements in Interpersonal Communication

The basic elements involved in interpersonal communication process are:

1. Sender; person who sends information.
2. Receiver: person who receives the information sent.
3. Message: content of information sent by sender.
4. Feedback: response from receiver.

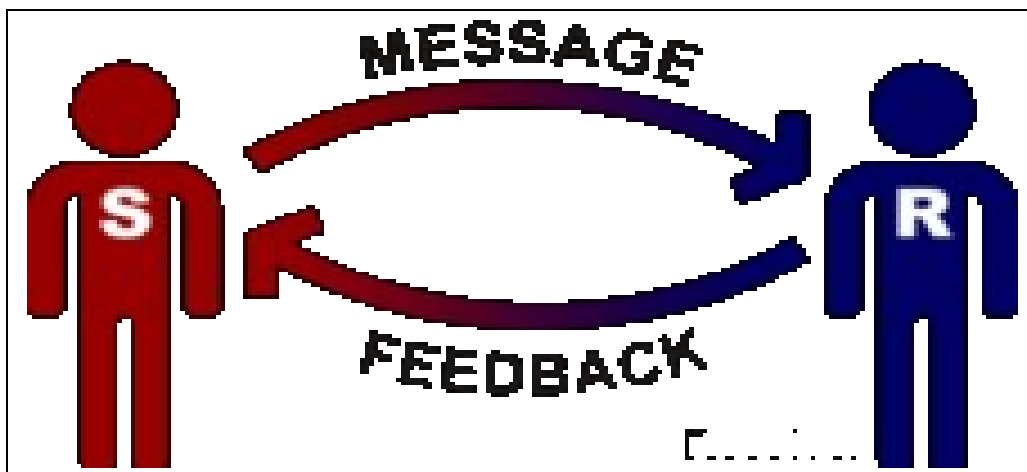

The diagram above graphically depicts the four basic elements of communication mentioned above. The two human beings standing at the extreme ends (left and right) represent the sender and receiver of the message respectively. The two arrows equally show the direction of the messages as sent by the two human beings at the extreme ends.

### **3.2.5 Barriers against Effective Interpersonal Communication**

#### **Emotions**

Sometimes when people communicate an idea or matter across, the receiver can feel how the sender perceives the subject matter. Often messages are interpreted differently for different people. Extreme emotions are most likely to hinder effective communication because the idea or message may be misinterpreted. It's always best to avoid responding or reacting to the subject matter when you're upset or angry because most of the time, you'll not be able to think in a clear manner.

#### **Filtering**

This is where the sender manipulates the information that he communicates to the receiver. The purpose of this is because sometimes people would shape and reform the message so that it appears and sounds favourable to the receiver. Filtering information may mislead the receiver into thinking something favourable and the let down may be upsetting if it is found out that information has been filtered.

#### **Overloaded with Information**

Too much information about the same subject matter may be confusing. For example, you have 50 e-mails on the same subject matter, each e-mail contains a little part of the subject matter. It would be better to have one e-mail from the sender which includes all the information in clear and simple form with only the information that you asked for. Normally, the human brain can only take in so much information to process, overloading it with information will exceed our human processing capacity, and the receiver would misunderstand or not understand at all what the sender is telling them.

#### **Defensiveness**

Humans tend to refuse for a mutual understanding when they feel that they are being threatened or are put in a position in which they are at a disadvantage. Defensiveness normally consists of attacking what the sender tells you, putting out sarcastic remarks, questioning their motives or being overly judgmental about the subject matter.

#### **Cultural Difference**

Sometimes our culture may be a huge hinderance for effective interpersonal communication. When two people with different cultures



communicate, they often do not understand each other's cultures and may misunderstand the true meaning of what each other are trying to convey through such a sense. For example, Japanese people would say "ハイ" (pronounced as 'ha-i') and Americans may misunderstand that they are saying "hi". This makes the intentions unclear between both people.

### **Jargon**

Not everyone understands each other's jargon words. Jargon should be avoided when talking to someone who isn't familiar with you personally or within your organization.

## **3.2.6 Overcoming the Barriers of Effective Interpersonal Communication**

### **Simplify Language**

By structuring your language to clear simplistic sentences, the receiver would be able to easily understand what the sender is saying. For example, jargon can be used within your organization as it will only use one word rather than a whole sentence to explain what you are trying to communicate across.

### **Constrain Emotions**

Hold back emotions whilst discussing a certain sensitive issue. Speaking in a neutral manner allows mutual understanding to occur and for both sender and receiver to communicate in a rational manner.

### **Listen Actively**

Often, when the sender says something, the receiver normally hears but does not listen. Place yourself in the sender's position and try to understand exactly what they are trying to convey to you. The receiver is trying to understand fully what the sender is trying to say, so putting the receiver in the sender's point of view makes understanding much easier.

### **Feedback**

Done by the sender, as a word of confirmation by using closed ended questions such as "Did you understand what I just said?" or "Is what I said clear to you?", or using an open ended question to have the receiver summarize the message. This results in the sender knowing that the receiver has fully understood what is being communicated.

## SELF ASSESSMENT EXERCISE 2

Interpersonal communication is said to be contextual and complicated. Explain

### 3.3 Interpersonal Communication and Relationship

Communication and relationship are intertwined. One of the most fundamental outcomes of human communication is the development of social networks, and no such networks are more fundamental to our lives than relationships. Our relationships are essential to our learning, growth and development. It is in relationship that most of our purposeful message sending activities take place.

The desire for relationships is universal; they are important to men and women. When we are deprived of relationship for long periods, depression sets in, self doubt surfaces, we find it difficult to manage even the basics of daily life.

Relationship is formed whenever reciprocal data processing occurs, i.e., when two or more individuals mutually take account of one another's verbal or non-verbal activities. This reciprocal data processing which we can call interpersonal communication is the means, through which relationships of all types are initiated, develop, grow and deteriorate.

Relationship can be dyadic (involving two persons), triadic (three persons) or quadradic. They can also be short term or long-term. But the longer the duration, the greater the investment one is willing to commit into the relationship. Relationship can also be casual or intimate.

#### 3.3.1 Advantages of Interpersonal Relationships

1. To lessen loneliness: Contact with other human being often lessens loneliness. You want to feel that someone loves, likes and cares for you. Close relationships assure you of protections and someone will be there when needed.
2. To secure stimulation: Human beings need stimulation. Through human contact, we derive intellectual, physical and emotional stimulation. We are **stimulotropics**.
3. For self-knowledge and self-esteem: You learn about yourself through contact with others. Your self-perception is greatly influenced by what you think others think of you. You are able to see yourself in different perspectives as you relate with people. Besides,

relationships help enhance self-esteem and self worth. When you have a friend, you feel desirable and worthy. A supportive partner relationship enhances your self-esteem.

4. To enhance physical and emotional health: Interpersonal relationship can help you to overcome depression and its consequent physical illness. Isolation contributes to high blood pressure, high cholesterol, obesity, smoking, and lack of physical exercise.
5. To maximise pleasure and minimise pain: Through interpersonal relationship, you are able to share your joy and good fortune as well as share your pain and sorrow.

### **3.3.2 Disadvantages of Interpersonal Relationships**

- 1) Pressure for exposure: Close relationships put pressure on you to reveal yourself and to expose your vulnerabilities. This may backfire when the relationship deteriorates and these are weaknesses used against you.
- 2) Increased obligations: As you get involved in close relationships, the demands on you will also increase. You will need to make sacrifices because whatever you have will no longer be entirely your own. On the positive side, your partner shares your losses and you share in your partner's gains. Emotional obligation is of course the most difficult demand, because it is not easy to be emotionally responsive and sensitive.
- 3) Increased Insulation: Intimate relationship can result in abandoning other relationships.
- 4) Difficulty in dissolving: Once you are involved, a relationship may prove difficult to get out of. (e.g. Religion and Marriage) Where a lot of money is committed, getting out may mean giving up the fortune as well. And if there is eventual break up, the pain, cost and trouble of such dissolution may be calamitous and catastrophic.

### **3.3.3 Stages in Relationship Building**

#### **Initiation**

Here the relationship begins with social initiation. You have perceptual contact- you see, hear, and perhaps smell the person; you get physical picture- gender, approximate age, height etc. You exchange both verbal and non-verbal messages.

#### **Exploration**

Immediately after the first stage, you begin to explore the potentials of the other person and the possibility of further pursuing the relationship. You experiment and try to learn more about the other person and reveal yourself.

### **Intensification**

At this level, the individuals have arrived at a decision- which they may or may not verbalise- that they wish the relationship continue. Individuals acquire a good deal of knowledge of the communication behaviour of the other involved, and at the same time a number of joint rules, shared language and relational rituals will emerge. Relationship at this stage, may deteriorate, or continue to develop.

### **Formalisation**

The relationship here becomes formalised and established e.g. Two people entering a business partnership ratify legal agreements. With an individual being hired for a job, the employee and employer may sign a contract. In love relationship, a formal bonding makes take the form of engagement or wedding rings.

### **Redefinition**

As the relationship continues, there may be need to redefine some of the joint rules of the relationship. Dissatisfaction in any of the parties may call for redefinition, which may likely result in deterioration of the relationship. If a repair of the relationship cannot be worked out then, it will result in dissolution.

### **Dissolution**

At this point, the bonds between the ex-partners are broken. The individuals begin to look at each other as individuals rather than halves of a pair.

## **SELF ASSESSMENT EXERCISE 3**

Justify the place of relationship in Interpersonal communication.

## **4.0 CONCLUSION**

Communication occurs at different levels. Communication is grouped by virtue of the level it belongs. These levels are otherwise known as context, which means different levels at which communication occurs. It can also be referred to as the kinds of communication that are available.

Communication within oneself is called Intra-personal communication. Those that involve two or more persons are referred to as Interpersonal communication. The one involving a group of people is called Group communication and so on.

## **5.0 SUMMARY**

The unit has been able to discuss in appreciable details the various contexts of communication. It examined the specific context like Intra-personal and Interpersonal Communication; Group Communication; Public Communication; and Mass Communication. The unit stressed the link between interpersonal communication and relationship. It looked at stages in relationship building as well as exploring the advantages and disadvantages of interpersonal relations

## **6.0 TUTOR–MARKED ASSIGNMENT**

Make a strong case for the place of communication in human relationship.

## **7.0 REFERENCES/FURTHER READINGS**

Baran, S.J. (2002). *Introduction to Mass Communication*. New York: McGraw Hill.

Bitner, R. (1989) *Mass Communication: An Introduction*. New Jersey: Prentice Hall.

Sambe J.A. (2005). *Introduction to Mass Communication Practice in Nigeria*. Ibadan: Spectrum Books Limited.

## **UNIT 4 GROUP AND PUBLIC COMMUNICATION**

## CONTENTS

- 1.0 Introduction
- 2.0 Objectives
- 3.0 Main Content
  - 3.1 Group Communication
  - 3.2 Public Communication
- 4.0 Conclusion
- 5.0 Summary
- 6.0 Tutor–Marked Assignment
- 7.0 References/Further Readings

### 1.0 INTRODUCTION

This unit examines the concept and nature of group and public communication. This is done under the following subtitles:

1. Definition of Group communication;
2. Various kinds of theories of Group communication;
3. Definitions and concept of Public communication

### 2.0 OBJECTIVES

At the end of this unit, you should be able to:

- give a vivid account of the concept of group communication
- identify the theories of group communication
- explain the concept of public communication.

### 3.0 MAIN CONTENT

#### 3.1 Group Communication

This form of communication occurs among a small number of people for the purpose of solving a problem. The group must be small enough so that each member has a chance to interact with all the other members.

The communication process in group communication is more complex than in interpersonal communication because the group members are made up of several sender-receivers. As a result, there are more chances for confusion. Messages are also more structured in small groups because the group is meeting for a specific purpose.

It uses the same channels as are used in interpersonal communication, and there is also a good deal of opportunity for feedback. It also occurs in a more formal setting than in interpersonal communication.

Robert Bales carried out the first important research study of small group communication. As a social psychologist, he published his work in a series of books and articles in the early and mid 1950s (e.g., Bales, 1950, 1953; Bales & Strodtbeck, 1951). This research entailed the content analysis of discussions within groups making decisions about "human relations" problems (i.e., vignettes about relationship difficulties within families or organizations). The social psychologist made a series of important discoveries. First, group discussion tends to shift back and forth relatively quickly between the discussion of the group task and discussion relevant to the relationship among the members. He believed that this shifting was the product of an implicit attempt to balance the demands of task completion and group cohesion, under the presumption that conflict generated during task discussion causes stress among members, which must be released through positive relational talk. Second, task group discussion shifts from an emphasis on opinion exchange, through an attentiveness to values underlying the decision, to making the decision. This implication that group discussion goes through the same series of stages in the same order for any decision-making group is known as the *linear phase model*. Third, the most talkative member of a group tends to make between 40 and 50 percent of the comments and the second most talkative member between 25 and 30, no matter the size of the group. As a consequence, large groups tend to be dominated by one or two members to the detriment of the others.

The linear phase model seems to be the most influential of these discoveries made by Bales. The idea that all groups performing a given type of task go through the same series of stages in the same order was replicated through the 1950s, 1960s and 1970s; with most finding four phases of discussion. For example, communication researcher B. Aubrey Fisher (1970) showed groups going sequentially through an orientation stage, a conflict stage, a stage in which a decision emerges and a stage in which that decision is reinforced. Much of this research (although not necessarily Fisher's) had two fundamental flaws. First, all group data was combined before analysis, making it impossible to determine whether there were differences among groups in their sequence of discussion. Second, group discussion content was compared across the same number of stages as the researcher hypothesized, such that if the researcher believed there were four stages to discussion, there was no way to find out if there actually were five or more. In the 1980s, communication researcher Marshall Scott Poole (Poole & Roth, 1989) examined a sample of groups without making these errors and noted substantial differences among them in the number and order of stages.

He hypothesized that groups finding themselves in some difficulty due to task complexity, an unclear leadership structure or poor cohesion act as if they feel the need to conduct a "complete" discussion and thus are more likely to pass through all stages as the linear phase model implies, whereas groups feeling confident due to task simplicity, a clear leadership structure and cohesion are more likely to skip stages apparently deemed unnecessary.

Another milestone in the study of group discussion content was early 1960s work by communication researchers – Thomas Scheidel and Laura Crowell (1964) regarding the process by which groups examine individual proposed solutions to their problem. They concluded that after a proposal is made, groups discuss it in an implied attempt to determine their "comfort level" with it and then drop it in lieu of a different proposal. In a procedure akin to the survival of the fittest, proposals viewed favourably would emerge later in discussion, whereas those viewed unfavourably would not; the authors referred to this process as "spiralling." Although there are serious methodological problems with this work, other studies have led to similar conclusions. For example, in the 1970s, social psychologist L. Richard Hoffman noted that odds of a proposal's acceptance is strongly associated with the arithmetical difference between the number of utterances supporting versus rejecting that proposal. More recent work has shown that groups differ substantially in the extent to which they spiral.

### 3.1.2 Group Communication Theories

Stephen Littlejohn (1992) in his book titled **Theories of Human Communication** made a categorization of such theories/models as presented below:

#### **GENERAL ORGANIZING MODEL**

According to Barry Collins and Harold Guetzkow, a task group is confronted with two types of problems. They are:

Task Obstacles - difficulties encountered by the group, such as planning an event or approving a policy and;

Interpersonal Obstacles - difficulties encountered between people, making ideas clear to others, handling conflict and differences:

- In any group discussion, members deal simultaneously with both task and interpersonal obstacles



- Assembly effect is when task and interpersonal work is integrated effectively
- Group rewards are positive (a successful event is a task reward, the fun involved in planning it the interpersonal reward) or negative (if rewards are negative the group may find it more difficult next time)
- Synergy is the effort expended by the group in solving tasks (effective synergy) and dealing with interpersonal obstacles (intrinsic synergy)

## **GROUPTHINK THEORY**

According to Irving Janis (1999:286), Groupthink is a mode of thinking that people engage in when they are deeply involved in a cohesive in-group, when the members' strivings for unanimity override their motivation to realistically appraise alternative courses of action. The theory has the following features:

- Groupthink occurs when cohesiveness is high
- Consensus-seeking tendency of close-knit groups can cause them to make inferior decisions
- Groups often don't discuss all available options
- The solutions are often not examined
- Groups often fail to seek expert opinion
- Groups are often highly selective in the way they handle information

Eight symptoms of groupthink

- illusion of invulnerability
- belief in inherent morality of the group
- collective rationalization
- out-group stereotypes
- self-censorship
- illusion of unanimity
- direct pressure on dissenters
- self-appointed mindguards

## INTERACTION PROCESS ANALYSIS

The theory aims to explain the pattern of responses in a small group and proposes four categories for interaction. They are:

- Positive and mixed actions - seems friendly, dramatizes, agrees
- Attempted Answers - gives suggestions, opinions and information
- Questions - asks for information, opinions and suggestions
- Negative and mixed actions - disagrees, shows tension, unfriendly

The theory holds that one way for group to release tension is dramatize (tell stories), called fantasy themes, which helps build common identity. The theory also believes in two classes of communication behaviour, namely, socioemotional - represented by positive and negative actions like seeming friendly, showing tension and; task behavior - represented by suggestions, opinions, and information INTERACTION ANALYSIS (Interact Model of Decision Emergence) Popularised by Aubrey Fisher upholds the following assumptions:

- An Interact is the act of one person followed by the act of another
- Interacts are classified according to content (the message) and the relationship dimension (non-verbal manner of the message)
- Groups are systems, bound by a definable context with which the members interact
- Verbal interaction dictates the final outcome
- All groups go through similar phases or stages before consensus is reached
- Groups share a common life cycle
- Theory is based on observable behaviour not inference or speculation
- Decision emergence is reached by a four stage process
  - orientation - clarification and agreement
  - conflict - decline of ambiguity and increase in strong reactions
  - emergence - unfavourable statements decrease, replaced by ambiguity (just wondering..) co-operation develops
  - reinforcement - brief, creates group solidarity, virtual disappearance of unfavorable reactions
- Decision modification - cyclical, several proposals are introduced, discussed and reintroduced at a later time (in a modified form perhaps)

## **SELF ASSESSMENT EXERCISE 1**

Synthesise the basic assumptions of the group communication theories described above in your own words.

### **3.2 Public Communication**

Here the (sender receiver) speaker sends a message (the speech) to an audience. The speaker usually delivers a highly structured message, using the same channels as in interpersonal or small-group communication. The channels here are more exaggerated than in interpersonal communication. The voice is louder and the gestures are more expansive because the audience is bigger. Additional visual channels, such as slides or the computer programme Power Point might be used. Opportunity for verbal feedback is limited in most public communication. The setting is also formal.

## **SELF ASSESSMENT EXERCISE 2**

The communication process in public communication is more complex than in interpersonal communication. Discuss

### **○ CONCLUSION**

Group communication occurs between a number of people for the purpose of solving problem. One major challenge with group communication is the complex nature of the players, that is, the sender-receivers. This is because the players are many, which could then result in confusion. Messages are also more structured in small groups because the group is meeting for a specific purpose. Public communication is encompassing. It is not restricted to a group but 'to whom it may concern'.

## **5.0 SUMMARY**

The unit has been able to show the nature of group and public communication. More importantly, the unit explored the various theories in studying group communication. The theories include General Organizing Model; Groupthink Theory; Interaction Process Analysis; Interaction Analysis (Interact Model Of Decision Emergence); The theories are needed to understand the very essence of group communication.

## **6.0 TUTOR-MARKED ASSIGNMENT**

Give a vivid description of the following theories: Groupthink Theory; Interaction Process Analysis; Interaction Analysis; Structuration Theory and Contingency Theory.

## **7.0 REFERENCES/FURTHER READINGS**

Baran, S.J. (2002). *Introduction to Mass Communication*. New York: McGraw Hill.

Bitner, R. (1989). *Mass Communication: An Introduction*. New Jersey: Prentice Hall.

Sambe J. A. (2005). *Introduction to Mass Communication Practice in Nigeria*. Ibadan: Spectrum Books Limited.

## **UNIT 5    CROSS    CULTURAL    /    INTERNATIONAL COMMUNICATION**

### **CONTENTS**

- 1.0 Introduction
- 2.0 Objectives
- 3.0 Main Content
  - 3.1 Cross Cultural Communication
  - 3.2 International Communication
- 4.0 Conclusion
- 5.0 Summary
- 6.0 Tutor–Marked Assignment
- 7.0 References/Further Readings

### **1.0 INTRODUCTION**

This unit examines the concept of cultural and international communication. This is done under the following subtitles:

1. The concept of cross cultural communication;
2. The concept of international communication

### **2.0 OBJECTIVES**

At the end of this unit, you should be able to:

- discuss the concept of cultural communication
- explain the concept of international communication.

### **3.0 MAIN CONTENT**

#### **3.1 Cross Cultural Communication**

When we encounter people from other cultures, we may fail to understand them because of differences in language, values, gestures, emotional expression, norms, rituals, rules, expectations, family background, and life experiences.

Cultures also differ in the meaning of slang, even if people *think* they're speaking the same language. In Ireland, when people say "I was pissed", it means "I was drunk" -- *not* "I was mad". Irish people say "Where's the crack in this town?" to refer to parties and fun -- *not* drugs. Sometimes understanding vocabulary is not enough.

Michelle LeBaron (2003) noted:

*All communication is cultural -- it draws on ways we have learned to speak and give nonverbal messages. We do not always communicate the same way from day to day, since factors like context, individual personality, and mood interact with the variety of cultural influences we have internalized that influence our choices. Communication is interactive, so an important influence on its effectiveness is our relationship with others. Do they hear and understand what we are trying to say? Are they listening well? Are we listening well in response? Do their responses show that they understand the words and the meanings behind the words we have chosen? Is the mood positive and receptive? Is there trust between them and us? Are there differences that relate to ineffective communication, divergent goals or interests, or fundamentally different ways of seeing the world? The answers to these questions will give us some clues about the effectiveness of our communication and the ease with which we may be able to move through conflict.*

LeBaron observed further that the challenge is that even with all the goodwill in the world, miscommunication is likely to happen, especially when there are significant cultural differences between communicators. Miscommunication may lead to conflict, or aggravate conflict that already exists. We make -- whether it is clear to us or not -- quite different meaning of the world, our places in it, and our relationships with others. In this module, cross-cultural communication will be outlined and demonstrated by examples of ideas, attitudes, and behaviours involving four variables:

1. Time and Space
2. Fate and Personal Responsibility
3. Face and Face-Saving
4. Nonverbal Communication

As our familiarity with these different starting points increases, we are cultivating cultural fluency -- awareness of the ways cultures operate in communication and conflict, and the ability to respond effectively to these differences.

### **SELF ASSESSMENT EXERCISE 1**

What do you understand by Cross-cultural communication? Cite relevant examples.

### 3.2 International Communication

International communication could be defined as the communication between two or more nations or communication across international boundaries. International communication arose because of the need to maintain international friendship and relations as well as to understand and keep abreast of happenings around the world. This is one of the core objectives of international communication.

International communication also enhances the job of diplomats who may use it as a tool of diplomacy. Most wars amongst nations or between one country and another had their remote and immediate causes connected to the inability of the combatants to talk meaningfully at a round table or the inability to understand and appreciate the other side's point of view and opinion due to poor international relations and information management abilities of the diplomats involved.

The international communication scene in the last 35 years has been characterized by divisions especially, as it concerns the flow of world news and information. Some countries are now regarded as 'information-rich nations' while others are termed 'information-poor nations'. The information-rich nations are those nations with enough human, natural and technological resources to exploit the production and distribution of global information and communication. The information-poor nations, on the other hand, lack the required resources even for local production and distribution of news and information, let alone of producing and distributing for global consumption. They are usually mere consumers of world news and information no matter in whose tastes they are produced.

The information-rich nations are usually regarded as the developed Western capitalist nations. They are also called the North or the First World. The countries under this information group have reached an advanced stage in their sociopolitical cum economic development. They are more concerned with the production and distribution of media hardware and software. Examples of some of these countries include the United State (US), Great Britain, France and some developed capitalist nations in Europe.

The information-poor nations are the 'underdeveloped' or 'developing' nations of the world. Their major problem is underdevelopment, which cuts across both the human and natural resources. The information-poor nations are usually found in Africa, Latin America and Asia. Hence, they are often referred to as the Third World or simply, the South. The economy and socio-political structures of these nations are still 'developing', thus, they are more of consumers than producers of global

mass communication. Some of the countries under this group include almost all the countries in Africa, Latin America and some parts of Asia.

In between these two broad divisions or groups, is the Second World Nations. They are neither very rich in information and communication resources nor are they too poor to be mere consumers or receivers of global news and information. The nations under this group were mostly associated with socialism/communism during the Soviet Union era. They are thus referred to as the East during the 'Cold War'. Some of these countries under this group include Russia, Communist China and the former members of the WARSAW PACT whose economies and political structures are well developed or reaching an advanced stage in their development.

In recent years, however, most nations of the world, especially the Third World and the Second World nations have become very skeptical about the nature, principles and objectives underlying the need for international communication. Their fears were as a result of the bombardment of their airwaves and other mass media channels with foreign media materials and messages, which are antithetical to their sociopolitical and economic development. Even in the area of hardware supplies, the First World nations still dominate and make the Second and Third World nations their dumping grounds for their unused or overproduced media hardware.

## **WHY STUDY INTERNATIONAL COMMUNICATION**

Lester Markel (1976) notes that:

*Foreign news is a misnomer. In this interdependent world, we are affected by almost any event almost anywhere... international news is not foreign, it is local, and it is immediate and highly relevant to the nation.*

This view by Markel underlines the need for international communication. Most nations of the world have discovered that they cannot survive without some form of social, economic and political co-operation with other nations. Therefore, efforts have been increased at the international level in order to positively exploit this interdependency. Apart from the other tools used to enhance international relations and diplomacy, international communication stands out as a major means through which a healthy social, economic and political co-operation amongst nations could be achieved.



International communication also helps to promote world peace and unity. This is not an overstatement. As we noted earlier, international communication involves the gathering and dissemination of news, information, views, ideologies, philosophies etc. across the globe. It also involves the interpretation and analysis of these news, information, views, ideologies, philosophies etc.; therefore, the proper study of international communication as an arm of mass communication will enhance this particular function. And when news, information, ideologies, philosophies etc are put in their proper perspective and given in-depth analysis and interpretation, there will be greater understanding among the citizens of the world. This will further promote global understanding, peace and unity.

International communication also aids the promotion of understanding between the different cultures involved in the global communication arena. The major news agencies in the world today (AP, UPI, AFP, REUTERS etc), for instance, recruit and maintain international correspondents in major cities all over the world. These correspondents live among the people where they cover and therefore, must try to understand their languages, mores, values and philosophies of life and existence if they must cover and report them successfully. This understanding will eventually enhance the better appreciation of the cultures of these different societies.

International communication has also brought to the fore the concept of global village, as discussed in Marshal McLuhan's "The Medium is the Message". This concept of global village is better referred to as the 'Villagisation of the Globe' in this volume. This concept, undoubtedly, discusses the effects of the improvement on communication technologies and facilities which have made the gathering and dissemination of global news and information very easy and more exciting. With these improvements, events and news in far away countries could be received and disseminated in other distant countries as they occur, making the globe look like an ordinary village.

Media systems of many nations have undergone positive changes as a result of the impact of international communication. This is particularly true in the Third World where the various media systems are desirous of countering the negative effects of cultural/media imperialism. In the process, they undergo a lot of positive changes necessary for growth so as to be able to compete favourably with media systems of the developed countries.

## **SELF ASSESSMENT EXERCISE 2**

Considering the notion that all communication is cultural, justify the need for international communication.

#### **4.0 CONCLUSION**

International communication is needed to prevent culture shock as well as enhancing the understanding of cultural imperialism and its attendant effects. Culture shock is the confusion and disorientation caused by contact or mingling with civilization other than one's own. Cultural imperialism, on the other hand, refers to the subjugation of a local culture and the imposition of an alien culture on the local culture.

#### **5.0 SUMMARY**

The unit has been able to look at international communication as an arm of mass communication with precise definitions that capture the rationale for this unit. The unit also gives an insight into the nature of international communication, especially the need for the study of international communication in international relations and world politics. Finally, the unit brings to the fore the fact that all forms of communication is cultural.

#### **6.0 TUTOR-MARKED ASSIGNMENT**

Cross cultural/International communication is powered by the new communication technologies in agreement with the postulation of the Canadian Literary scholar, Marshal McLuhan who popularised the concept of the global village otherwise known as the 'Villagisation of the Globe'. Discuss this assertion.

#### **7.0 REFERENCES/FURTHER READINGS**

- Baran, S.J. (2002). *Introduction to Mass Communication*. New York: McGraw Hill.
- Bitner, R. (1989). *Mass Communication: An Introduction*. New Jersey: Prentice Hall.
- Griffin. (1994). *A first look at communication theory*. (2nd Ed.). McGraw Hill.
- Sambe J.A.(2005). *Introduction to Mass Communication Practice in Nigeria*. Ibadan: Spectrum Books Limited.
- Littlejohn, S. (1992). *Theories of Human Communication (5th Ed.)*. California: Wadsworth Publishing.

## **MODULE 3      MEDIA OF COMMUNICATION**

Unit 1	Print Media: Books, Newspaper, Magazine etc
Unit 2	Book Publishing
Unit 3	Broadcast Media: Radio Television and Radio
Unit 4	Narrowcast media: Film and Cinema, Cable Television
Unit 5	The New Media: Online Newspapers and Magazines, Internet Radio etc

### **UNIT 1      PRINT      MEDIA:      BOOKS,      NEWSPAPER,      MAGAZINE ETC**

#### **CONTENTS**

1.0	Introduction
2.0	Objectives
3.0	Main Content
3.1	The Printing Revolution
3.2	Books
3.3	Newspapers
3.4	Magazines
4.0	Conclusion
5.0	Summary
6.0	Tutor–Marked Assignment
7.0	References/Further Readings

#### **1.0      INTRODUCTION**

This unit examines the following arms of the print media:

1. Books
2. Newspapers
3. Magazines

#### **2.0      OBJECTIVES**

At the end of this unit, you should be able to:

- explain in appreciable details the meaning and origin of books
- discuss the meaning and origin of newspapers
- discuss the meaning and origin of magazines.

### 3.0 MAIN CONTENT

#### 3.1 The Printing Revolution

The advent of printing is the key to our modern consciousness, argued Marshall McLuhan. Printing was so important because it allowed mass communication. The Chinese were using wooden block presses as early as A.D 600 and had movable clay type by A.D 1000. A simple movable metal type was even in use in Korea in the 13<sup>th</sup> century. These existed before 1446 when Gutenberg perfected his printing technology. Gutenberg was a goldsmith and metallurgist. He hit upon his idea of using metal type crafted from lead moulds in place of type made from wood or clay. The movable type was not only durable enough to print page after page but letters could be arranged and rearranged to make any message possible. And he was able to produce virtually identical copies.

Also, Gutenberg, instead of using his invention to produce attractive artwork like the Korean metal mould printing, he used it to produce books for profit. He stressed quality over quantity; partly because of his reverence for the book he was printing- the Bible. He used the highest quality paper and ink and turned out far fewer volumes than he could have. The first Gutenberg Bible appeared in 1456. By the end of that century, 44 years later, printing operations existed in 12 European countries, and the continent was flooded with 20 millions volumes of 7,000 titles in 35,000 different editions.

With the discovery of the new world, most of the early settlers brought with them books that were oriented. However those early settlers did not find books central to their lives for a number of reasons. The first printing press arrived in North America in 1638, operated by a company called Cambridge press. Printing was limited to religious and government documents. The first book printed was *The Whole Booke of Psalms*, sometimes referred to as the *Bay Psalm Book* published in 1644. Publishing then required the permission of the colonial government before it could be done. Consequently, books continued to grow rapidly as printing technology improved.

#### 3.2 Books

##### 3.2.1 Development of Books

Development of books started with the invention of writing. Over 5,000 years ago, alphabets were developed independently in several places around the world. Ideogrammatic (picture-based) alphabets appeared in Egypt (as hieroglyphics), Sumerian (as cuneiform) and urban china.

Ideogrammatic alphabets require a huge number of symbols to convey even the simplest idea. Their complex nature meant that only a very selected few, intellectual elites, could read or write. The Sumerians developed the cuneiform to meet their need of a more precise writing, other than face-to-face communication as those enjoyed in their international trade across the Europe, Africa and Asia. Sumerians cuneiform slowly expanded, using symbols to represent sounds rather than objects and ideas. Around 1800 B.C, these were the first elements of a syllable alphabet -an alphabet employing sequences of vowels and consonants, that is, words

The syllable alphabet, aided by Semitic cultures, slowly developed, and eventually flowered in Greece around 800 B.C and was subsequently perfected. These alphabets of necessity were used for writing in trading, a development which helped their Greek city-states to thrive in business. However, a medium was necessary to carry this new form of communication. The Sumerians had used clay tablets, but the Egyptians, Greeks, and Romans eventually employed Papyrus, rolls of sliced strips of reed pressed together. Around 100 B.C the Romans began using parchment, a writing material made from prepared animal skins and in A.D 105 mid level Chinese bureaucrat Ts'ai Lun perfected a paper making process employing a mixture of pressed mulberry tree bark, water, rags and a sophisticated frame for drying and stretching the resulting sheet of paper.

With the emergence of literacy-the ability to effectively and efficiently comprehend and use written symbols-the social and cultural rules and structures of preliterate times began to change. However, communication was still quite limited, because writers could reach only those few literates who held their hand written scrolls or letters.

### **3.2.2 Convergence in Books**

Internet is changing the way books are distributed and sold. But this new technology, in the form of e-publishing, the publication of books initially or exclusively, online, offer a new way for writers ideas to be published. The physical form of books is changing. E-publishing can take the form of the d-books (digital books) and print on demand (POD) and many d-books are designed to be read on handheld computers called e-books.

#### **SELF ASSESSMENT EXERCISE 1**

How would you assess the reading culture of Nigerian students? Give reasons for your answer.

### 3.3 Newspaper

#### 3.3.1 History of Newspaper

In Renaissance Europe handwritten newsletters circulated privately among merchants, passing along information about everything from wars and economic conditions to social customs and "human interest" features. The first printed forerunners of the newspaper appeared in Germany in the late 1400's in the form of news pamphlets or broadsides, often highly sensationalized in content. Some of the most famous of these report the atrocities against Germans in Transylvania perpetrated by a sadistic *veovod* named Vlad Tsepes Drakul, who became the Count Dracula of later folklore.

In the English-speaking world, the earliest predecessors of the newspaper were *corantos*, small news pamphlets produced only when some event worthy of notice occurred. The first successively published title was *The Weekly Newes* of 1622. It was followed in the 1640's and 1650's by a plethora of different titles in the similar *newsbook* format. The first true newspaper in English was the *London Gazette* of 1666. For a generation it was the only officially sanctioned newspaper, though many periodical titles were in print by the century's end.

In England the press developed under the authoritarian atmosphere of the early seventeenth century. *Corantos*, one-page news sheets were printed in English in Holland in 1620. English men Nathaniel Butter, Thomas Archer and Nicholas Bourne eventually began printing their own occasional news sheet. They stopped publishing in 1641, the same year that regular, daily account of local news started appearing in other news sheets. These true forerunners of daily newspaper were called *diurnals*.

In Italy as early as 59 B.C, there was a publication of daily events bulletins called Acta Diurna (Actions of the day). They were posted in a public place for all to read. The earliest forerunner of the modern newspaper can be credited to the Chinese, with the publication of Tsing Pao at about 500 A.D.

As the technological advances of printing made their way across Europe, newspapers cropped up frequently. The first newspaper published in Germany was found in 1609 by Egenolph Emmel. As at 1633 there were at least 16 newspapers in Germany.

In 1704, postmaster Jelm Campell joined with Bartholomew Green to publish a newspaper called the *Boston News-Letter*. By 1721, The News-letter received competition from the *News England Courant*

published by James Franklin, the older brother of Benjamin Franklin. The *Courant* was popular and controversial; it distinguished itself and carried forth numerous editorial crusades against both church and state.

By 1729, in Philadelphia, Benjamin Franklin took over a family newspaper, started by Samuel Keimer and renamed it as the *Pennsylvania Gazette* and the *Virginia Gazette*. The latter proved especially important because of Virginia's influence on American independence. In 1734, John Peter Zenger began publishing the *New York Weekly* to counter Bradford's newspaper, the *New York Gazette* who mostly expressed the government line. Zenger's criticism of the colonial government got him into trouble, and he was later arrested and charged with seditious libel –publishing false and defamatory statements against the government. He, fortunately, won the case thus establishing “Truth as a defense Against Libel”. His lawyer was Andrew Hamilton.

After the American independence, the government of U.S had to determine for itself just how free a press it was willing to tolerate. In 1790, the congress adopted the first 10 amendments to the constitution, called **The Bills of Rights**. The first Amendment reads! Congress shall make no law ... abridging the freedom of speech, or of the press ...

### 3.3.2 Beginnings of Newspaper in America

In America, the first attempt at a newspaper was one started by the English printer, Benjamin Harris. He published in 1690 an edition of a newsletter titled *Publick Occurrences, Both Foreign and Domestick*. However, Harris could not continue publishing due to the problem he encountered with the Massachusetts government by being critical of the Indians. The first newspaper appeared in Boston in 1690, entitled *Publick Occurrences*. Published without authority, it was immediately suppressed, its publisher arrested, and all copies were destroyed. Indeed, it remained forgotten until 1845 when the only known surviving example was discovered in the British Library.

The first successful newspaper was the *Boston News-Letter*, begun by postmaster John Campbell in 1704. Although it was heavily subsidized by the colonial government the experiment was a near-failure, with very limited circulation. Two more papers made their appearance in the 1720's, in Philadelphia and New York, and the Fourth Estate slowly became established on the new continent. By the eve of the Revolutionary War, some two dozen papers were issued at all the colonies, although Massachusetts, New York, and Pennsylvania would remain the centers of American printing for many years. Articles in colonial papers, brilliantly conceived by revolutionary propagandists,

were a major force that influenced public opinion in America from reconciliation with England to full political independence.

At the end of the war in 1783, there were forty-three newspapers in print. The press played a vital role in the affairs of the new nation; many more newspapers were started, representing all shades of political opinion. The no-holds barred style of early journalism, much of it libelous by modern standards, reflected the rough and tumble political life of the republic as rival factions jostled for power. The ratification of the Bill of Rights in 1791 at last guaranteed freedom of the press, and America's newspapers began to take on a central role in national affairs. Growth continued in every state.

By 1814 there were 346 newspapers. In the Jacksonian populist 1830's, advances in printing and papermaking technology led to an explosion of newspaper growth, the emergence of the "Penny Press"; it was now possible to produce a newspaper that could be sold for just a cent a copy. Previously, newspapers were the province of the wealthy, literate minority. The price of a year's subscription, usually over a full week's pay for a laborer, had to be paid in full and "invariably in advance." This sudden availability of cheap, interesting reading material was a significant stimulus to the achievement of the nearly universal literacy now taken for granted in America.

### **3.3.3 Newspaper and the Industrial Revolution**

The industrial revolution, as it transformed all aspects of American life and society, dramatically affected newspapers. Both the numbers of papers and their paid circulations continued to rise. The 1850 census catalogued 2,526 titles. In the 1850's powerful, giant presses appeared, able to print ten thousand complete papers per hour. At this time the first "pictorial" weekly newspapers emerged; they featured for the first time extensive illustrations of events in the news, as woodcut engravings made from correspondents' sketches or taken from that new invention, the photograph.

During the Civil War the unprecedented demand for timely, accurate news reporting transformed American journalism into a dynamic, hardhitting force in national life. Reporters, called "specials," became the darlings of the public and the idols of youngsters everywhere. Many accounts of battles turned in by these intrepid adventurers stand today as the definitive histories of their subjects.

Newspaper growth continued unabated in the postwar years. An astounding 11,314 different papers were recorded in the 1880 census. By the 1890's the first circulation figures of a million copies per issue



were recorded (ironically, these newspapers are now quite rare due to the atrocious quality of cheap paper then in use, and to great losses in World War II era paper drives) At this period appeared the features of the modern newspaper, bold "banner" headlines, extensive use of illustrations, "funny pages," plus expanded coverage of organized sporting events. The rise of "yellow journalism" also marks this era. Hearst could truthfully boast that his newspapers manufactured the public clamor for war on Spain in 1898.

This is also the age of media consolidation, as many independent newspapers were swallowed up into powerful "chains"; with regrettable consequences for a once fearless and incorruptible press, many were reduced to vehicles for the distribution of the particular views of their owners, and so remained, without competing papers to challenge their viewpoints. By the 1910's, all the essential features of the recognizably modern newspaper had emerged. In our time, radio and television have gradually supplanted newspapers as the nation's primary information sources, so it may be difficult initially to appreciate the role that newspapers have played in our history.

### **3.2.4 Functions of Newspapers**

Succinctly, newspaper helps to provide advantageous information on current affairs. Below are other advantages:

1. Newspapers help in doing genealogical searches for family and issues;
2. Newspapers alert people on upcoming events in sports, community activities (concerts, parades, etc.), and politics (gives one an edge when considering the total candidate for whom to vote);
3. Newspapers provide platform for speaking out on issues of public importance. This could make someone relevant in national discourse;
4. It provides relaxation through cartoons, puzzles, jokes etc;
5. Newspapers help in locating job opportunities, searches on what to buy and so on.

Sambe (2005) highlights the following as functions of newspaper:

1. Newspapers inform readers objectively about what is happening in their community, country and the world;

2. Newspaper comments on the news in order to bring development into focus;
3. Newspaper provides the means whereby persons who want to sell goods and services can advertise their wares;
4. Newspaper campaigns for desirable civic projects and to help eliminate undesirable conditions;
5. Newspaper gives readers a portion of entertainment;
6. Newspaper serves readers as a friendly counselor information bureau, and champion of their rights.

### **3.3.5 The Penny Press**

In the 1830s, there was the introduction of a new style of journalism and a new style of newspaper. Small newspapers with a lighter style, stressing not political issues but the crime, sex and gossip of the day, sold for one cent. The new publications ushered in the era of the penny press. It was a departure from the existing newspaper style, writing in dense prose and dealing with what often were complex political issues; thus an average American found little interest in these “Statesmen newspaper”.

The earliest penny press was the New York Sun, published in 1833 by Benjamin. H. Day. His innovation was to sell his paper so inexpensively that it would attract a large readership, which could then be sold to advertisers. Day succeeded because he anticipated a new kind of reader. Soon, there were many penny papers in all the major cities.

### **3.2.6 Yellow Journalism**

The penny press not only proved that sensational news sold at an inexpensive price could be successful, it also laid the ground work for an era of another kind of journalism – Yellow journalism.

Leading participants were Joseph Pulitzer, publisher of the *New York World* and William Randolph Hearst, who became the editor of the *San Francisco Examiner* in 1887. Hearst became famous for his pranks while in Harvard and was eventually expelled. He got newspaper experience from Pulitzer’s *World* and returned to San Francisco to apply the lesson of sensationalism from the penny press to big-city journalism. With bold, eye –gripping headlines and various escapades to generate or report news, Hearst’s *Examiner* began to climb in circulation and profits.

Hearst expanded his coast to New York and bought the *New York Morning Journal*, renamed it as the *New York Journal*. He hired one of Pulitzer's top illustrators; Richard F. Outcault, that marked the beginning of an outstanding battle in journalism. Outcault had drawn a cartoon about life in New York's crowded tenement that featured a child cartoon character. The extremely popular "kid" appeared in a yellow dress and became known as "Yellow kid". Outcault brought the kid to the *Journal* while George B. Links of Pulitzer's newspaper also had it within him. Appearing in the promotional literature of both newspapers, "the circulation war" was in full force, and a new title had been given to this era of sensational, competitive and in many ways irresponsible journalism- *Yellow journalism*. It remained as a way of selling newspaper well into the 1900s and can still be seen today.

## **SELF ASSESSMENT EXERCISE 2**

Discuss the disadvantages of newspaper.

### **3.4 Magazines**

#### **3.4.1 The Growth of Magazines**

The first magazine was believed to have been started in 1704 by Daniel Defoe. It was a weekly periodical called *the Review*. Defoe's *Review* was distinguished from the Newspapers of the era because he published features materials in addition to news.

Two publications – *the Tattler and Spectator* emerged out of the journalistic style of Defoe. *Tattler* was published in 1709 by Richard Steele while the *Spectator* came up in March 1711 by both Steele and Joseph Addison. The *Spectator* grew in London and was the first magazine to make a contribution to literature.

In the United States of America, Andrew Bradford began publishing American magazine in 1741, followed by Benjamin's *General magazine*. Between 1741 and 1794, 45 new magazines appeared. Entrepreneurial printers with the intention to attract educated, cultural, moneyed gentlemen copied the successful London magazine. Subsequently, other magazines emerged. Some are the *Saturday Evening Post*, 1821; *Harpers* 1850, and *Atlantic Monthly* 1857.

Some factors that fuelled the growth of magazines include cheaper printing and growing literacy as well as the spread of social movement such as abolitionism and labour reform.

Magazines began to have mass circulation after the American Civil War. Apart from growth in literacy and availability of cheaper printing that were responsible, the arrival of Women magazine was also responsible. In addition were the Postal Act of 1879, which permitted mailing magazine at cheap rates and the spread of the rail road which carried people and publications westward from the east coast, as well as the reduction in the prices of magazines due to competing price war.

Of significance to this trend is the era of muckraking, which attracted large readership. However, the mass circulation was made possible by industrialization which provided people with leisure and more personal income.

Following the end of World War II, deep alterations in American culture and, in particular, the advent of television changed the relationship between magazines and their audiences. Magazine could not match the reach of television despite its large circulation. Many of the mass circulated magazines closed up. Magazine therefore sought solace in specialization and a life style orientation.

### **3.4.2 Convergence in Magazine Publishing**

Online magazine or webzine have emerged made possible by convergence of magazine and the Internet. For example, Time and Mother Jones now have online edition. There are also others who are strictly online.

Online magazines face certain challenges as at now. One is how the subscription for them should be charged. This difficulty is imposed because web users are accustomed to free access to sites. Besides, pure online magazines must generate their original content, an undertaking that is very expensive. Besides, they have to compete online for readers and advertisers as equals with webzine subsidized by paper magazine. In addition, purely online magazines must also compete with the other websites on the Internet.

### **3.4.3 The Influence of Advertisers on Magazines**

The sustenance and profitability of magazine business, made possible by advertisement has brought much influence on magazine content. Since the major aim of every business is to make profit, no magazine would like to lose its advertiser. Therefore magazine editors are very cautious in new presentation so as not to offend their advertisers. The questions emerging is that how can a magazine function, offering depth, variety and detail content when its editorial content is influenced by advertisers?

### SELF ASSESSMENT EXERCISE 3

Trace how magazine grew and the factors that were responsible for its mass circulation.

#### 4.0 CONCLUSION

Printing brought expansion in literacy. People found it necessary to learn how to read and write. Printing had become one of the engines driving the industrial revolutions. It was responsible for building and disseminating bodies of knowledge and the refinement of new machines.

Printing made newspapers and magazines possible, brought scientific and technological development, and technology as a result of industrialization gave us mass market magazines. However, one major challenge facing the printing world is that most Nigerians prefer watching television or listening to radio than reading books.

#### 5.0 SUMMARY

The unit has been able to discuss in appreciable details the basic components of the print world, namely: books, newspaper and magazine. The unit examined the origin and the historical base of these print products.

The unit traced the development of books to over 5,000 years ago when alphabets were developed independently in several places around the world and ideogrammatic (picture-based) alphabets appeared in Egypt (as hieroglyphics), Sumerian (as cuneiform) and urban china.

The newspaper was traced to have started with handwritten newsletters which were circulated privately among merchants, passing along information about everything from wars and economic conditions to social customs and "human interest" features. The unit established that the first printed forerunners of the newspaper appeared in Germany in the late 1400's in the form of news pamphlets or broadsides, often highly sensationalized in content.

The unit also noted that magazine started in 1704 by Daniel Defoe as a weekly periodical called *the Review*. The unit underscored the place of advertisement in newspaper venture, and submitted that sustenance and profitability of magazine business is hinged on advertisement.

## **6.0 TUTOR-MARKED ASSIGNMENT**

Explain the concept of yellow journalism. Name with convincing reasons a current newspaper in Nigeria that practices Yellow Journalism.

## **7.0 REFERENCES/FURTHER READINGS**

Baran, S.J. (2002). *Introduction to Mass Communication*. New York: McGraw Hill.

Bitner, R. (1989). *Mass Communication: An Introduction*. New Jersey: Prentice Hall.

Sambe J.A. (2005). *Introduction to Mass Communication Practice in Nigeria*. Ibadan: Spectrum Books Limited.

## **UNIT 2     BOOK PUBLISHING**

### **CONTENTS**

- 1.0 Introduction
- 2.0 Objectives
- 3.0 Main Content
  - 3.1 Origin and Concept of Book Publishing
  - 3.2 Understanding Book Publishing and its Terminologies
  - 3.3 Steps in Book Publishing
- 4.0 Conclusion
- 5.0 Summary
- 6.0 Tutor-Marked Assignment
- 7.0 References/Further Readings

### **1.0 INTRODUCTION**

This unit gives the basic understanding of book publishing, as well the steps involved. The unit is subdivided as follows:

1. Origin and concept of books
2. Understanding book publishing and its terminologies
3. Steps in book publishing

### **2.0 OBJECTIVES**

At the end of this unit, you should be able to:

- discuss the origin and concept of book
- explain the process of book publishing and its terminologies
- enumerate the steps in book publishing.

### **3.0 MAIN CONTENT**

#### **3.1 Origin and Concept of Book Publishing**

Long before the coming of the printing press, books were made of vellum (calf or lamb skin) because of its durability. In San Simeon (also known as Hearst's Castle), there are lampshades that William Randolph Hearst had made from 15th century Gregorian prayer books and the vellum is still in excellent condition. For books that took more than a year to produce, paper was too flimsy. However, for print books, vellum was too costly to produce.

One notable historical figure in the printing world was Gutenberg. In 1452, Gutenberg conceived of the idea for movable type. In his

workshop, he brought together the technologies of paper, oil-based ink and the wine-press to print books. The printing press was not a single invention. It was the aggregation in one place, of technologies known for centuries before Gutenberg. One thing to remember is that Gutenberg got credit for an invention that was thought to have been developed simultaneously in Holland and in Prague.

Below are other inventions brought together by Gutenberg in his pursuit of a printing press:

- The adaptation for printing, of the wine or olive oil, screw-type press that had been in use for hundreds of years, throughout Europe and Asia.
- The adaptation of block-print technology - known in Europe since the return of Marco Polo from Asia at the end of the 13th century.
- The development of mass production paper-making techniques. Paper was brought from China to Italy in the 12th C. but was thought too flimsy for books.
- The development of oil-based inks. These had been around since the 10th century, but smeared on the vellum used to make books. The religious manuscripts used an egg-based tempera. This was unsuitable for printing with type.
- Gutenberg's contribution to printing was the development of a punch and mold *system* which allowed the mass production of the movable type used to reproduce a page of text. These letters would be put together in a type tray which was then used to print a page of text. If a letter broke down, it could be replaced. When the printing of the copies of one page was finished, the type could be reused for the next page or the next book.

These technological improvements stretch across five centuries. They do not cluster around Gutenberg's time.

The first books to show up in print shops were bibles and religious tracts. The next books to attract publishers were the "humanist" texts brought back from Byzantium by the Crusades, and other texts of antiquity but there was little or no printing of new ideas.

Many people went into the printing business and went out again. The reason was that the distribution of books was poorly organized. The



market was there, and the potential for filling the demand, but the transport and control and "advertising" mechanisms were not in place.

In addition, there was still a low literacy rate in Europe. Most people did not know how to read at all. But non-literates were still affected by the book trade because the elites, who controlled society, were affected by books. And people who could not read still had access to book culture because there were traveling raconteurs who stood in the market and read from books as a means of making a living as entertainers.

### **3.1.1 Four Important Periods in the History of the Book**

#### **1. 7th to 13th Century**

This is the era of religious publications; the age of religious "manuscript" book production when Bibles and other religious publications were made. Books in this period are entirely constructed by hand, and are largely religious texts whose creation is meant as an act of worship.

#### **2. 13th to 15th Century**

This is the era of secular book production; the secularization of book production. Books are beginning to be produced that do not serve as objects of worship, but that try to explain something about the observable world. The difficulty with the spread of such knowledge is that production is still taking place via pre-print - manuscript - methods. The production of secular books was driven by two things:

- a. The rise of universities in Europe, spreading from Italy.
- b. The return of the crusaders in the 13th century, who brought with them texts from Byzantium. These books, written during the Greek and Roman periods in history, focused on this-world concerns.

#### **3. 15th to 16th Century**

The first printed books. These are print versions of traditional works like the Bible, books of hours (prayer books) and the religious calendars.

#### **4. 16th to 17th Century**

New information is put into books that have important consequences for European life and society.

### **3.1.2 Definition of Book Paper**

Paper is a general term used to describe a type of paper suitable for printing, especially offset printing. Below are more specific definitions of various kinds of book paper.

### **Book Paper**

This can have many different finishes and may be coated or uncoated. Premium book paper is also called Bible grade. More opaque than bond paper and good for 2-sided printing, book paper is also characterized by excellent folding qualities and durability. Book paper has a basic size of 25" x 38" and the basis weights range from 22 to 150 lbs. Offset papers are especially suitable for offset printing due to increased resistance to water and picking.

### **Bible Paper**

This is a thin, lightweight, opaque printing paper with a basic size of 25" x 38". It is generally made from 25% cotton and linen rags or flax in combination with chemical wood pulp. Bible paper typically has a long life. Bible paper is a premium grade of book paper. The name of Bible paper comes from it being the type of paper commonly used for Bibles.

### **Newsprint**

It is an inexpensive paper made primarily of mechanically ground wood pulp rather than chemical pulp. **Newsprint** has a shorter lifespan than other papers but is cheap to produce in bulk and is the least expensive paper that can withstand normal printing processes. Newsprint has a basic size of 24" x 36". **Newsprint** is the type of paper used for newspapers and may also be used for comic books, some newsletters and trade magazines and buy/sell/trade classified ad weeklies.

### **Cover Paper**

Is the term for a heavy, stiff paper with a basic size of 20" x 26". Some cover paper may have matching book paper with the same colours and finishes. It is **also known as** card stock. Cover paper is used for book covers, file folders, presentation folders, greeting cards, business cards, postcards, and brochures.

## **SELF ASSESSMENT EXERCISE 1**

This book in your hand is made up of which paper? Give reasons for your answer.

### **3.2 Understanding Book Publishing and its Terminology**

### 3.2.1 Understanding Book publishing

Book Publishing could be defined as a professional activity involving the selection, development and editing of manuscripts; contractual agreements with authors or copyright holders; production and marketing of printed books under the firm's imprint; and the assumption of the risks associated with these activities.

Wikipedia (online dictionary) defines publishing as the process of production and dissemination of literature or information – the activity of making information available for public view. In some cases, authors may be their own publishers. Traditionally, the term refers to the distribution of printed works such as books (the "book world") and newspapers. With the advent of digital information systems and the Internet, the scope of publishing has expanded to include electronic resources, such as the electronic versions of books and periodicals, as well as websites, blogs, games and the like.

Publishing includes the stages of development, acquisition, copyediting, graphic design, production – printing (and its electronic equivalents), and marketing and distribution of newspapers, magazines, books, literary works, musical works, software and other works dealing with information, including the electronic media.

### 3.2.2 Book Publishing Terminologies

#### **Publisher**

Is the person, organization, or company that *finances* the book and controls the editing, designing, printing, and marketing of it. The publisher is the risk taker and owns the physical books. Money flows in one direction and one direction only: from the publisher to the author, normally in the form of royalties on sales.

#### **Self-Publisher**

This is when the author doubles as the publisher. Authors who choose to self-publish do so because they want more control over the process, or because they can (with certain kinds of books) make more money than they would receive in royalties if someone else published it. Of course some have to self-publish because they can't find someone else willing to publish their work. If you are paying for the production and printing of your book, you are the publisher. Anyone else involved, regardless of what they refer to themselves as, is merely a contractor.

#### **Producer**

A book producer handles any or all aspects of putting a book together and getting it printed. This includes editing, design, typesetting, scanning and image preparation, digital page composition, obtaining printer quotes, and working with the printer. Often the publisher performs these functions, but there are companies, such as Fox Meadow, that produce books for other publishers (including self-publishers) on a contract basis. Many book publishers with in-house design and production staff will also produce books on the side to bring in some guaranteed income. The important thing to remember here is that the producer doesn't own the books. The publisher does: he paid for them. After they are printed, the books are delivered to the publisher, who handles marketing and distribution and receives all income from sales.

### **Vanity Publishers**

A vanity publisher is a company that puts out books under its own imprint but actually requires authors to pay the entire cost of production — in advance. The royalty rate to the author may be higher than what true publishers pay, but of course, having all its money up front, such a firm has little incentive to market a book, and you may see little return. You may also have trouble getting possession of the books. Beware! Self-publish instead. It will probably cost less, you'll be in complete control, and you'll get *all* the revenue.

### **Subsidy Publishing**

This is a grey area between true publishing and vanity publishing. Here the author makes a contribution to the cost of publishing the book. Although the author and the publisher are really co-publishers, usually only the publisher's imprint appears on the book. The author normally receives a higher royalty than in the true publishing model, but without knowing exactly what the publisher's actual costs for producing and marketing the book are, it is a safe bet that the publisher will establish a royalty that short-changes the author. If you as an author wants to participate in a subsidy publishing arrangement, get all the facts you can and make sure you have a detailed contract.

### **The Printer**

Is he who prints and usually binds the book. At one time, publishers had their own presses. Today, most book printing is done by specialized book manufacturers who have no other involvement in the project other than providing technical advice on how to prepare material for them. You pay them to print it. Some printers provide design and typesetting services as well. Generally, specialized book manufacturers provide

better pricing and more options than general commercial printers can on a book.

### **Book Distributor**

Is the one who acts as the link between publisher and retailer in cases where the publisher does not want to be involved in shipping books and collecting money from retailers. The distributor receives orders from retailers, ships books, invoices and collects revenue, and handles returns. This is normally done on a commission basis. It is quite a costly service, but almost essential for a small publisher who wants to sell books in stores all across the country, or in a different country. Some large book retailers unfortunately will not even purchase books directly from small publishers. A distributor usually handles books from several publishers. Large national publishers may do their own distribution, or own a separate distribution company. The publisher is still responsible for marketing the book that is, creating a demand for it through advertising, promotion, author tours, etc. The distributor merely fills the resulting orders.

### **Book Pack**

Is an eligible trade book packaged and sold together with a non-book item, such as a CD or a toy. Exception: books sold with a CD inside the cover that is not visible from the outside are not considered book packs, but as regular books.

### **Children's Book**

A **trade book** published for the children's or young adults' markets, including picture books, easy-to-read books, chapter books and young adult books. **Educational books** intended for elementary school students are also considered children's books.

### **Co-publishing**

Is a *joint* financial investment by two or more publishers to conceive, produce and print, under their respective imprints, individual titles or collections to be sold in their respective markets. Provided all other eligibility criteria are satisfied, co-published books are eligible, but applicants may claim as eligible sales only their portion of the total revenue. The partner publisher of the applicant may be foreign-owned.

### **Educational Book**

Are instructional materials, such as textbooks, teachers' guides and eligible **learning kits** designed for the primary, secondary or post-secondary school markets.

### ***New Edition***

Is the publication in modified form of a book previously published by the same or a different publisher. In contrast with a new title, a book is considered a new edition if more than 50% of its content is taken from the previously published book. In contrast with a reprint, a new edition must have at least one of the following: substantial changes in the format or binding; reformatting of at least 50% of the text; either substantial changes to at least 25% of the original written content or at least 25% new written content; or substantial changes to the illustrations, other than on the cover.

### ***Non-Print Material***

*Are* audiotape, audio CD, CD-ROM, e-book, or similar product.

### ***Own Titles***

Are *titles* for which the publisher holds publication, development and marketing rights for its own market.

### ***Reference Year***

Is *the* publisher's financial year that its Aid to Publishers application is based on and which is used to complete the application form.

### ***Scholarly Book***

A book based on research that makes a significant contribution to the development of knowledge in a given field and is subject to peer review prior to publication. Together with **trade books** and **educational books**, scholarly books are one of the three Book Publishing Industry Development Programme (BPIDP) commercial categories.

### ***Self-Published Title***

A publication written by authors who are shareholders or owners of the publishing firm.

### ***Trade Book***

A book intended for the public in general, including literary works, how-to books, dictionaries, encyclopedias and reference works intended for professionals. Any title that is not an educational or a scholarly book is considered to be a trade book.

### ***Vanity Title***

A publication dependent on a financial contribution from, or an initial purchase by, the author.

## **SELF ASSESSMENT EXERCISE 2**

What are the challenges facing book publishing in Nigeria?

### **3.3 Steps in Book Publishing**

Below are the steps in book publishing as enumerated by wikipedia:

#### **Submission by Author or Agent**

Book and magazine publishers spend a lot of their time buying or commissioning copy. At a small press, it is possible to survive by relying entirely on commissioned material. But as activity increases, the need for works may outstrip the publisher's established circle of writers. Writers often first submit a query letter or proposal. The majority of unsolicited submissions come from previously unpublished authors. When such manuscripts are unsolicited, they must go through the slush pile, in which acquisitions editors sift through to identify manuscripts of sufficient quality or revenue potential to be referred to the editorial staff. Established authors are often represented by a literary agent to market their work to publishers and negotiate contracts.

#### **Acceptance and Negotiation**

Once a work is accepted, commissioning editors negotiate the purchase of intellectual property rights and agree on royalty rates. The authors of traditional printed materials sell exclusive territorial intellectual property rights that match the list of countries in which distribution is proposed (i.e. the rights match the legal systems under which copyright protections can be enforced). In the case of books, the publisher and writer must also agree on the intended formats of publication — mass-market paperback, "trade" paperback and hardback are the most common options.

The situation is slightly more complex if electronic formatting is to be used. Where distribution is to be by CD-ROM or other physical media,

there is no reason to treat this form differently from a paper format, and a national copyright is an acceptable approach. But the possibility of Internet download without the ability to restrict physical distribution within national boundaries presents legal problems that are usually solved by selling language or translation rights rather than national rights. Thus, Internet access across the European Union is relatively open because of the laws forbidding discrimination based on nationality, but the fact of publication in, say, France, limits the target market to those who read French.

Having agreed on the scope of the publication and the formats, the parties in a book agreement must then agree on royalty rates, the percentage of the gross retail price that will be paid to the author and the advance payment. This is difficult because the publisher must estimate the potential sales in each market and balance projected revenue against production costs. Royalties usually range between 10-12% of recommended retail price. An advance is usually 1/3 of first print run total royalties. For example, if a book has a print run of 5000 copies and will be sold at \$14.95 and the author receives 10% royalties, the total sum payable to the author if all copies are sold is \$7475 (10% x \$14.95 x 5000). The advance in this instance would roughly be \$2490. Advances vary greatly between books, with established authors commanding large advances.

### **Editorial Stage**

Once the immediate commercial decisions are taken and the technical legal issues resolved, the author may be asked to improve the quality of the work through rewriting or smaller changes, and the staff will edit the work. Publishers may maintain a house style, and staff will copy edit to ensure that the work matches the style and grammatical requirements of each market. Editing may also involve structural changes and requests for more information. Some publishers employ fact checkers.

### **Prepress**

When a final text is agreed upon, the next phase is design. This may include artwork being commissioned or confirmation of layout. In publishing, the word "art" also indicates photographs. This process prepares the work for printing through processes such as typesetting, dust jacket composition, specification of paper quality, binding method and casing, and proofreading.

The activities of typesetting, page layout, the production of negatives, plates from the negatives and, for hardbacks, the preparation of brasses for the spine legend and imprint are now all computerized. Prepress



computerization evolved mainly in about the last twenty years of the 20th century. If the work is to be distributed electronically, the final files are saved as formats appropriate to the target operating systems of the hardware used for reading.

#### **4.0 CONCLUSION**

The period between the 13th and 16th centuries saw the rise of a print-dominated society, one that moved away from the Church's monopoly of information that existed during the manuscript book period. This was initially fueled by the reproduction of classic texts of antiquity. It was further fueled by the development of new kinds of books in science.

These factors led to the development of books as elements of propaganda and religious education. There were social and political and economic changes that made print important. Those changes might not have happened as quickly or perhaps at all without print.

On the academic front, the development of the printing press represented a revolution for communicating the latest hypotheses and research results to the academic community and supplemented what a scholar could do personally. But this improvement in the efficiency of communication created a challenge for libraries which have had to accommodate the weight and volume of literature.

Today, publishing academic journals and textbooks is a large part of an international industry. The shares of the major publishing companies are listed on national stock exchanges and management policies must satisfy the dividend expectations of international shareholders.

#### **5.0 SUMMARY**

The book publishing industry has become a big business the world over. The Unit examined in great detail book publishing, right from its origin to its present state. The publishing terminologies and types of book papers were equally examined.

#### **6.0 TUTOR-MARKED ASSIGNMENT**

The reading culture of Nigerians especially, students are dying. This has negative effects on the book publishing business. Critically assess this statement in the light of the prevailing circumstances in Nigeria.

#### **7.0 REFERENCES/FURTHER READINGS**

Epstein, J (1987). *Book Business: Publishing Past, Present, and Future*.  
Place and name of publisher unknown.

Schiffrin, A. (2000). *The Business of Books: How the International  
Conglomerates Took Over Publishing and Changed the Way We  
Read*. Place and name of publisher unknown.

Ugrešić, D. (2003). *Thank You for Not Reading*. Place and name of  
publisher unknown.

## **UNIT 3 BROADCAST MEDIA: RADIO AND TELEVISION**

### **CONTENTS**

- 1.0 Introduction
- 2.0 Objectives
- 3.0 Main Content
  - 3.1 Radio
  - 3.2 Television
- 4.0 Conclusion
- 5.0 Summary
- 6.0 Tutor-Marked Assignment
- 7.0 References/Further Readings

### **1.0 INTRODUCTION**

This unit examines the following arms of the broadcast media:

1. Radio
2. Television

### **2.0 OBJECTIVES**

At the end of this unit, you should be able to:

- discuss television as a broadcast medium
- discuss radio as broadcast medium.

### **3.0 MAIN CONTENT**

#### **3.1 Radio: The First Broadcast**

Telegraph and telephone were important predecessors of radio. Samuel Morse developed the telegraph in 1844 and it was a principal means of news and information. Alexander Graham Bell demonstrated his telephone in 1876 and this invention gave birth to the concept of “broadcasting” i.e. sending of a single message as sound which can be simultaneously received by large numbers of people in different locations.

In Germany, Heinrich Rudolf Hertz successfully transmitted electromagnetic waves without any other form of conduction. Hertz’s name is adopted as the measure of all radio frequencies (i.e. MHz-Mega Hertz).

In 1906, De Forest perfected the audio tube, which became the vacuum tube, making possible the clear transmission of voice and music. On Xmas eve (1906), Reginald Fessenden made what is generally regarded as the first broadcast. Greater success came with the replacement of Fessenden's primitive telephone microphone with De Forest's audio tube, which offered for greater fidelity of sound.

A series of broadcasts followed and radio began to gain ground. In 1912, the sinking of the Titanic foregrounded the potential of wireless as a lifesaver when the rescue operation was coordinated by David Sarnoff of Marconi Wireless telegraphy. Much credit for the development of radio as a national entertainment, news and commercial medium goes to David Sarnoff. Sarnoff, as an assistant traffic manager in Marconi Company in 1918 and 1916, recognized the potential of radiotelephony long before others in the field did. He wrote:

*I have in mind a plan of development which would make Radio a "household utility" in the same sense as the piano or phonograph. The idea is to bring music into the home by wireless.*

In 1920, Westinghouse engineer Frank Conrad began broadcasting phonograph music over a transmitter in his Pittsburgh garage as part of his experiments in radiotelephony. The popularity of Conrad's broadcasts prompted Westinghouse official to formalize the programming transmitted over station KDKA and stimulated a demand for receivers. The station began on Nov 2, 1920 with a broadcast of the results of the Harding-Cox presidential election. People soon flocked to local department stores to buy primitive crystal receivers. Other radio stations were established. A.T and T signed WEAf on the air but sold it to RCA in 1926. Out of that sale came NBC. NBC operated two networks until 1943 when one was sold, which became ABC. Two others, CBC and Mutual also were part of the development of early commercial radio. For noncommercial stations, the National Public radio began regular programming in 1971.

### **3.1.2 The Contribution of Hertz and Marconi**

Heinrich Hertz, a German physicist in 1888 made the sensational discovery of radio waves, a form of electromagnetic radiation with wavelengths too long for our eyes to see, confirming Maxwell's ideas. He devised a transmitting oscillator, which radiated radio waves, and detected them using a metal loop with a gap at one side. When the loop was placed within the transmitter's electromagnetic field, sparks were produced across the gap. This proved that electromagnetic waves could be sent out into space, and be remotely detected. These waves were

known as 'Hertzian Waves' and Hertz managed to detect them across the length of his laboratory.

Another milestone was made by the Italian Guglielmo Marconi who was fascinated by Hertz's discovery, and realised that if radio waves could be transmitted and detected over long distances, wireless telegraphy could be developed. He started experimenting in 1894 and set up rough aerials on opposite sides of the family garden. He managed to receive signals over a distance of 100 metres, and by the end of 1895, had extended the distance to over a mile. He approached the Italian Ministry of Posts and Telegraphs, informing them of his experiments. The Ministry was not interested and so his cousin, Henry Jameson-Davis arranged an interview with Nyilliam Preece, who was Engineer-in-Chief to the British Post Office.

He came to England in February 1896 and gave demonstrations in London at the General Post Office Building. His transmissions were detected 1.5 miles away, and on 2<sup>nd</sup> September at Salisbury plain the range was increased to 8 miles. In 1897 he obtained a patent for wireless telegraphy, and established the Wireless Telegraph and Signal Company at Chelmsford. The world's first radio factory was opened there in 1898. On 11<sup>th</sup> May 1897 tests were carried out to establish that contacts were possible over water. A transmitter was set up at Lavernock Point, near Penarth and the transmissions were received on the other side of the Bristol Channel at the Island of Holm, a distance of 3.5 miles. The Daily Express was the first newspaper to obtain news by wireless telegraphy in August 1898, and in December of that year communication was set up between Queen Victoria's Royal yacht, off Cowes and Osborne House. The Queen received regular bulletins on the Prince of Wales' health, by radio, from the yacht, where he was convalescing.

Also in December of that year, wireless communication was set up between the East Goodwin light ship and the South Foeland lighthouse. On 3<sup>rd</sup> March 1899 Marconi obtained a lot of publicity when the first life was saved by wireless telegraphy, which was used to save a ship in distress in the North Sea. By the summer cross channel communication had been established and the first ocean newspaper published bulletins sent by wireless.

About this time Marconi began to develop tuned circuits for wireless transmission, so that a wireless can be tuned to a particular frequency, to remove all other transmissions except the one of interest. He patented this on 26<sup>th</sup> April 1900, under the name of 'Tuned Syntonic Telegraphy'. On Thursday 12<sup>th</sup> December 1901, Marconi and his associates succeeded in transmitting a signal across the Atlantic Ocean. He sailed to Newfoundland with G.S. Kemp and P.W. Paget, and received a

transmission from Poldhu, Cornwall. The transmission was received at Signal Hill using a kite aerial. The British government and admiralty were greatly impressed and many people wanted to invest in the new technology. Demand grew and large numbers of ships carried the new apparatus, which saved many lives at sea. One of the most famous occasions was when the Titanic sank. Signals transmitted by its Marconi wireless summoned help and saved many lives.

Receivers at this time were mainly crystal sets, which were extremely insensitive and unselective. They were connected to a pair of headphones and required a long aerial.

### 3.1.3 Landmarks in Radio History

- Discovery of electromagnetic induction by Michael Faraday In 1831. Faraday used mathematical models suggested by Faraday's law of induction to propose that electromagnetic forces extended into the empty space around the conductor.
- **William Henry Ward** in April 1872 received [U.S. Patent 126,356](#) for radio development.
- Maxwell equations were developed by James Clerk Maxwell and between 1861 and 1865, James Clerk Maxwell made experiments with electromagnetic waves. In 1873, as a result of experiments, Maxwell first described the theoretical basis of the propagation of electromagnetic waves in his paper to the Royal Society, "A Dynamical Theory of the Electromagnetic Field".
- In July 1872, **Mahlon Loomis** received [U.S. Patent 129,971](#) for a "wireless telegraph". This patent utilizes **atmospheric electricity** to eliminate the overhead wire used by the existing telegraph systems. It did not contain diagrams or specific methods. It is substantially similar to **William Henry Ward's** patent.
- Towards the end of 1875, while experimenting with the telegraph, Thomas Edison noted a phenomenon that he termed "etheric force", announcing it to the press on November 28. He abandoned this research when Elihu Thomson, among others, ridiculed the idea.
- Between 1893 and 1894, Roberto Landell de Moura, a Brazilian priest and scientist, conducted experiments. He did not publicize his achievement until 1900.
- In 1878, David E. Hughes was the first to transmit and receive radio waves when he noticed that his induction balance caused noise in the

receiver of his homemade telephone. He demonstrated his discovery to the Royal Society in 1880 but was told it was merely induction.

- In 1884, Temistocle Calzecchi-Onesti at Fermo in Italy invented a tube filled with iron filings, called a "coherer".
- Between 1884 and 1886, Edouard Branly of France produced an improved version of the coherer.
- In 1885, Edison took out [U.S. Patent 465,971](#) on a system of radio communication between ships (which later he sold to Marconi).
- Between 1886 and 1888, Heinrich Rudolf Hertz validated Maxwell's theory through experiment. He demonstrated that radio radiation had all the properties of waves (now called Hertzian waves), and discovered that the electromagnetic equations could be reformulated into a partial differential equation called the wave equation. But he saw no practical use for his discovery. For more information see Hertz's radio work.
- Claims have been made that Murray, Kentucky farmer Nathan Stubblefield invented radio between 1885 and 1892, before either Tesla or Marconi, but his devices seemed to have worked by induction transmission rather than radio transmission.
- Nikola Tesla developed means to reliably produce radio frequencies, publicly demonstrated the principles of radio, and transmitted long distance signals. He holds the US patent for the invention of the radio, defined as "wireless transmission of data". In 1891 Tesla began his research into radio. He later published an article, "The True Wireless", concerning this research. Tesla was the first to apply the mechanism of electrical conduction to wireless practices.
- Oliver Lodge transmitted radio signals on August 14, 1894 (one year after Tesla and one year before Marconi) at a meeting of the British Association for the Advancement of Science at Oxford University. On 19 August 1894 Lodge demonstrated the reception of Morse code signalling via radio waves using a "coherer". He improved Edouard Branly's coherer radio wave detector by adding a "trembler" which dislodged clumped filings, thus restoring the device's sensitivity. In August 1898 he got [U.S. Patent 609,154](#), "Electric Telegraphy", that made wireless signals using Ruhmkorff coils or Tesla coils for the transmitter and a Branly coherer for the detector. This was key to the "syntonic" tuning concept. In 1912 Lodge sold the patent to Marconi.

- In November 1894, the Bengali Indian physicist, Jagdish Chandra Bose, demonstrated publicly the use of radio waves in Calcutta, but he was not interested in patenting his work. Bose ignited gunpowder and rang a bell at a distance using electromagnetic waves, proving that communication signals can be sent without using wires. The 1895 public demonstration by Bose in Calcutta was before Marconi's wireless signalling experiment on Salisbury Plain in England in May 1897. In 1896, the Daily Chronicle of England reported on his UHF experiments: "The inventor (J.C. Bose) has transmitted signals to a distance of nearly a mile and herein lies the first and obvious and exceedingly valuable application of this new theoretical marvel."
- **Alexander Popov** was the first man to demonstrate the practical applications of radio waves. In 1894, the Russian physicist **Alexander Popov** built a **coherer**. On **May 7, 1895**, Popov performed a public demonstration of transmission and reception of radio waves used for communication at the Russian Physical and Chemical Society, using his coherer. Around March 1896 Popov demonstrated in public the transmission of radio waves, between different campus buildings, to the **Saint Petersburg** Physical Society. (This was before the public demonstration of the Marconi system around September 1896). In 1898 his signal was received 6 miles away, and in 1899 30 miles away. In 1900, Popov stated at the **Congress of Russian Electrical Engineers** that, "the emission and reception of signals by Marconi by means of electric oscillations was nothing new, as in America **Nikola Tesla** did the same experiments in 1893." Later Popov experimented with ship-to-shore communication. Popov died in 1905 and his claim was not pressed by the Russian government until 1945.
- In February 1893, Tesla delivers "On Light and Other High Frequency Phenomena" before the Franklin Institute in Philadelphia. In 1895, Marconi receives a telegraph message without wires a short distance (below a mile), but he did not send his voice over the airwaves. In March 1895, Popov transmitted radio waves between campus buildings in Saint Petersburg, but did not apply for a patent. In 1896, Tesla detected transmissions from his New York lab of low frequency (50,000 cycle per second) undamped waves with a receiver located at West Point, "a distance of about 30 miles."

### SELF ASSESSMENT EXERCISE 1

Radio as a medium of mass communication is said to have the highest number of audience and widest reach. Do you agree? Give reason for your answer.



## 3.2 Television: The Most Influential Medium

The word *television* is a *hybrid word*, created from both *Greek* and *Latin*. *Tele-* is Greek for "far", while *-vision* is from the Latin *visio*, meaning "*vision*" or "*sight*". It is often *abbreviated* as **TV** or the **telly**.

### 3.2.1 History of television

The **History of television** technology can be divided along two lines: those developments that depended upon both mechanical and electronic principles, and those which are purely electronic. From the latter descended all modern televisions, but these would not have been possible without discoveries and insights from the mechanical systems.

The operation basis for modern television could be traced to the development of the first workable device for generating electrical signals suitable for the transmission of a scene that people should see. Today's television system could be traced back to the discovery of the *photoconductivity* of the element *selenium* by *Willoughby Smith* in 1873, and the invention of a scanning disk in 1884 by a German student whose name was Paul Gottlieb Nipkow. Nipkow proposed and patented the first electromechanical television system in 1884. Nipkow's spinning disk design is credited with being the first television image rasterizer. Constantin Perskyi had coined the word *television* in a paper read to the International Electricity Congress at the International World Fair in Paris on August 25, 1900. Perskyi's paper reviewed the existing electromechanical technologies, mentioning the work of Nipkow and others. The photoconductivity of selenium and Nipkow's scanning disk were first joined for practical use in the electronic transmission of still pictures and photographs, and by the first decade of the 20th century halftone photographs were being transmitted by facsimile over telegraph and telephone lines as a newspaper service.

Developments in amplification tube technology later came in 1907. The first demonstration of the *instantaneous* transmission of still duotone images was by Georges Rignoux and A. Fournier in Paris in 1909, using a rotating mirror-drum as the scanner, and a matrix of 64 selenium cells as the receiver. This was advanced by Boris Rosing and his student Vladimir Kosma Zworykin in 1911, when they created a television system that used a mechanical mirror-drum scanner to transmit, in Zworykin's words, "very crude images" over wires to the electronic Braun tube (cathode ray tube) in the receiver. Moving images were not possible because, in the scanner, "the sensitivity was not enough and the selenium cell was very laggy".

### 3.2.2 Some Landmarks in Television History

- John Logie Baird, a Scottish inventor on March 25, 1925, gave a demonstration of televised silhouette images in motion at Selfridge's Department Store in London. Baird gave the world's first public demonstration of a working television system to members of the Royal Institution and a newspaper reporter on January 26, 1926 at his laboratory in London.
- In 1927, Baird transmitted a signal over 438 miles of telephone line between London and Glasgow.
- In 1928 Baird Television Development Company / Cinema Television broadcast the first transatlantic television signal, between London and New York, and the first shore-to-ship transmission. He also demonstrated an electromechanical color, infrared (dubbed "Noctovision"), and stereoscopic television, using additional lenses, disks and filters.
- In 1929, Baird became involved in the first experimental electromechanical television service in Germany. In 1931 he made the first live transmission, of the Epsom Derby. In 1932 he demonstrated ultra-short wave television. Baird's electromechanical system reached a peak of 240 lines of resolution on BBC television broadcasts in 1936, before being discontinued in favour of a 405-line all-electronic system developed by Marconi-EMI.
- On June 13, 1925 in the U.S., Charles Francis Jenkins demonstrated the transmission of the silhouette image of a toy windmill in motion from a naval radio station to his laboratory in Washington, using a lensed disk scanner with 48 lines per picture, 16 pictures per second. AT&T's Bell Telephone Laboratories transmitted half-tone images of transparencies in May 1925.
- On April 7, 1927, Herbert E. Ives of Bell Labs showcased a dramatic demonstration of television when he field tested reflected-light television systems using small-scale (2 by 2.5 inches) and large-scale (24 by 30 inches) viewing screens over a wire link from Washington to New York City, and over-the-air broadcast from Whippany, New Jersey.
- Alan Archibald Campbell-Swinton, an engineer gave a speech in London in 1911, reported in *The Times*, describing in great detail how distant electric vision could be achieved by using cathode ray tubes at both the transmitting and receiving ends. The speech, which expanded on a letter he wrote to the journal *Nature* in 1908, was the

first iteration of the electronic television method that is still used today.

- Kálmán Tihanyi, a Hungarian inventor in 1926 showcased television operating on the basis of continuous electron emission with accumulation and storage of released secondary electrons during the entire scan cycle.
- Philo Farnsworth on September 7, 1927, presented its Image Dissector camera tube which transmitted its first image, a simple straight line, at Farnsworth's laboratory at 202 Green Street in San Francisco.
- On 25 August 1934, Farnsworth gave the world's first public demonstration of a complete all-electronic television system at the Franklin Institute in Philadelphia
- Vladimir Zworykin and his team in 1931 successfully created their first successful electronic camera tube, dubbed the Iconoscope.
- In 1936 in Britain, Isaac Shoenburg began the world's first high-definition regular service which is still in use today. Shoenburg used Zworykin's idea to develop Marconi-EMI's own Emitron tube, which formed the heart of the cameras they designed for the BBC.

### 3.2.3 Development of Colour Television

John Logie Baird was the world's first to demonstrate colour transmission on July 3, 1928, using scanning discs at the transmitting and receiving ends with three spirals of apertures, each spiral with filters of a different primary color; and three light sources at the receiving end, with a commutator to alternate their illumination. On August 16, 1944, Baird gave a demonstration of a fully electronic colour television display.

Colour television in the United States had a protracted history due to conflicting technical systems vying for approval by the Federal Communications Commission (FCC) for commercial use. Mechanically scanned color television was demonstrated by Bell Laboratories in June 1929 using three complete systems of photoelectric cells, amplifiers, glow-tubes, and color filters, with a series of mirrors to superimpose the red, green, and blue images into one full color image.

In the electronically scanned era, the first colour television demonstration was on February 5, 1940, when RCA privately showed to members of the FCC at the RCA plant in Camden, New Jersey, a

television receiver producing colour images by optically combining the images from two picture tubes onto a single rear-projection screen.

NBC (owned by RCA) made its first field test of colour television on February 20, 1941. CBS began daily colour field tests on June 1, 1941. These color systems were not compatible with existing black and white television sets, and as no colour television sets were available to the public at this time, viewership of the colour field tests was limited to RCA and CBS engineers and the invited press. The War Production Board halted the manufacture of television and radio equipment for civilian use from April 22, 1942 to August 20, 1945, limiting any opportunity to introduce colour television to the general public.

On January 12, 1950, CBS gave the world's first demonstrations of colour television to the general public, showing an hour of colour programmes daily Mondays through Saturdays over WOIC in Washington, D.C., where they could be viewed on eight 16-inch colour receivers in a public building. This was done as part of the CBS campaign for FCC approval. This generated public interest and high demand.

On October 11, 1950, the FCC formally approved the CBS system as the U.S. colour broadcasting standard, after a series of hearings beginning in September 1949. The FCC found the RCA and CTI systems fraught with technical problems, inaccurate colour reproduction, and expensive equipment. An unsuccessful lawsuit by RCA delayed the world's first network colour broadcast until June 25, 1951, when a musical variety special titled simply *Premiere* was shown over a network of five east coast CBS affiliates. Viewership was again extremely limited: the programme could not be seen on black and white sets, and *Variety* estimated that only thirty prototype colour receivers were available in the New York area. Regular colour broadcasts began that same week with the daytime series *The World Is Yours* and *Modern Homemakers*.

Gradually, CBS colour broadcasting schedule expanded to twelve hours per week and the colour network expanded to eleven affiliates as far west as Chicago, but its commercial success was doomed by the lack of colour receivers necessary to watch the programmes, the refusal of television manufacturers to create adapter mechanisms for their existing black and white sets, and the unwillingness of advertisers to sponsor broadcasts seen by almost no one.

To overcome this commercial challenge, CBS bought a television manufacturer in April, and in September 1951, production began on the first and only CBS-Columbia colour television model. But it was too little, too late. Only 200 sets had been shipped, and only 100 sold, when

CBS pulled the plug on its colour television system on October 20, 1951, and bought back all the CBS colour sets it could to prevent lawsuits by disappointed customers.

Shortly before CBS colour even got on the air, the U.S. National Television System Committee (NTSC), worked in 1950–1953 to develop a colour system that was compatible with existing black and white sets and would pass FCC quality standards, with RCA developing the hardware elements. NTSC efforts paid off in July 1953 when it was granted approval and this led to the first publicly announced experimental TV broadcast of a programme using the NTSC "compatible colour" system, an episode of NBC titled *Kukla, Fran and Ollie* on August 30, 1953.

### 3.2.4 Some Landmarks in the Development of Colour Television

- NBC made the first coast-to-coast colour broadcast when it covered the Tournament of Roses Parade on January 1, 1954, NBC was naturally at the forefront of colour programming because its parent company RCA manufactured the most successful line of colour sets in the 1950s, and by 1959 RCA was the only remaining major manufacturer of colour sets.
- **Cuba** became the second country in the world to introduce colour television broadcasting, with Havana's Channel 12 using the NTSC standard and RCA equipment. This was done in 1958, but the color transmissions ended when broadcasting stations were seized in the **Cuban Revolution** in 1959, and did not return until 1975, using equipment acquired from Japan's **NEC Corporation**, and **SECAM** equipment from the Soviet Union, adapted for the NTSC standard.
- Guillermo González Camarena (1917–1965), invented Mexico first colour television transmission system. He received patents for colour television systems in 1942 (U.S. Patent 2,296,019), 1960 and 1962. It was similar to field sequential color receivers already demonstrated by John Logie Baird in England in 1939 and by CBS in the United States in August 1940. He obtained authorization to make the first publicly announced colour broadcast in Mexico, on February 8, 1963, of the program *Paraíso Infantil* on Mexico City's XHGC-TV.
- Canada experienced its colour television stations not until 1966. This was an extension of the rise in the neighbouring United States.

- In Europe, the delay in colour television was partly because there were fewer commercial motivations and being that European television broadcasters were predominantly state-owned at the time. Besides, there was the problem of continuing division on technical standards. In the 1950s, with the first SECAM patent being registered in 1956, many years had passed when the first broadcasts actually started in 1967. Not satisfied with the performance of NTSC and of initial SECAM implementations, the Germans unveiled PAL (phase alternating line) in 1963, technically similar to NTSC but borrowing some ideas from SECAM. The PAL system spread through most of Western Europe and on into the territories of the old British, Portuguese, Belgian, Dutch, Austro-Hungarian, Ottoman and Chinese Empires.
- In Italy, Indesit mooted the development of the *ISA* but the idea was scrapped. As a result, Italy was one of the last European countries to officially adopt the PAL system in 1977, after long technical experimentation.
- France, Luxembourg, and the Soviet Union along with their overseas territories opted for SECAM. SECAM was a popular choice in countries with a lot of hilly terrain, and technologically backward countries with a very large installed base of monochrome equipment, since the greater ruggedness of the SECAM signal could cope much better with poorly maintained equipment. The only real drawback of SECAM is that, unlike PAL or NTSC, post-production of an encoded SECAM is not really possible without a severe drop in quality.
- In September 10, 1960., **Japan**, NHK introduced colour television, using a variation of the NTSC system (called **NTSC-J**), other countries in the asia-pacific region did not adopt the NTS system until much later. Instead, they used the PAL system, such as Singapore (1973), New Zealand (1973) and Australia (1975), with India not introducing it until 1982. South Korea did not introduce colour (using NTSC) until 1980, although it was already manufacturing colour television sets for export.
- In Africa, the first colour television service was introduced on the Tanzanian island of Zanzibar, in 1973, using PAL. At the time, South Africa did not have a television service at all, owing to opposition from the apartheid regime, but in 1976, one was finally launched. Nigeria adopted PAL for colour transmissions in the mid-1970s, but countries such as Ghana and Zimbabwe continued with black and white until the late 1980s.

- Brazil became the first South American country to receive colour TV, using a specially-modified version of PAL called PAL-M, combining both NTSC and PAL, in contrast to most other countries in the Americas, which had adopted NTSC. Its first transmission was February 19, 1972.

### 3.2.5 Television Delivery System

Television signals were first transmitted over the air, and viewing traces were limited to the number of channel that could be picked up by rooftop antenna. Now, cable, satellite delivering systems and the web are treading the number of channels and programming options. We have:

1. Broadcast
2. Cable television
3. Wireless cable (multichannel multipoint distribution service, MMDS).
4. Direct broadcast satellite(DBS)
5. High-Definition television
6. Web-delivering system.-(interacting-combination of internet and broadcasting. It makes it possible to receive both television signals and the web, both over a television set and through a computer.

### SELF ASSESSMENT EXERCISE 2

Recall and summarise the coming of colour television in Nigeria.

## 4.0 CONCLUSION

In 1897, Guglielmo Marconi, “Father of Radio”, invented a way to transmit sound- the dots and dashes of Morse’s code- without using wires. Almost immediately, Marconi’s wireless became a useful way to communicate with ships at sea. By 1901, Marconi successfully transmitted wireless signal between Europe and North America (New Foundland). In the USA, Fessenden successfully superimposed a voice on to a continuous radio wave using a telephonic microphone, enabling the transmission of speech and music. In 1904, John A. Fleming developed a glass bulb tube- the diode tube which became the basis for radio signal amplification of voice transmissions.

Television gained subscribers faster than radio because of the excitement it brought. Television sets became hot cake and must buy for every home. The earliest commercially made sets sold by Baird in the

UK and the U.S. in 1928 were radios with the addition of a television device consisting of a neon tube behind a mechanically spinning disk (the Nipkow disk) with a spiral of apertures that produced a red postage-stamp size image, enlarged to twice that size by a magnifying glass. The Baird "Televisor" was also available without the radio. The Televisor sold in 1930-1933 is considered the first mass-produced set, selling about a thousand units. The first commercially made electronic television sets with cathode ray tubes were manufactured by Telefunken in Germany in 1934, followed by other makers in Britain (1936) and America (1938). The cheapest of the pre-World War II factory-made American sets, a 1938 image-only model with a 3-inch (8 cm) screen, cost US\$125, the equivalent of US\$1,732 in 2005. The cheapest model with a 12-inch (30 cm) screen was \$445 (\$6,256). An estimated 19,000 electronic television sets were manufactured in Britain, and about 1,600 in Germany, before World War II. About 7,000-8,000 electronic sets were made in the U.S. before the War Production Board halted manufacture in April 1942, production resuming in August 1945.

Television usage in the United States skyrocketed after World War II with the lifting of the manufacturing freeze, war-related technological advances, the gradual expansion of the television networks westward, the drop in set prices caused by mass production, increased leisure time, and additional disposable income. While only 0.5% of U.S. households had a television set in 1946, 55.7% had one in 1954, and 90% by 1962. In Britain, there were 15,000 television households in 1947, 1.4 million in 1952, and 15.1 million by 1968.

For many years different countries used different technical standards. France initially adopted the German 441-line standard but later upgraded to 819 lines, which gave the highest picture definition of any analogue TV system, approximately double the resolution of the British 405-line system. However this is not without a cost, in that the cameras need to produce four times the pixel rate (thus quadrupling the bandwidth), from pixels one-quarter the size, reducing the sensitivity by an equal amount. In practice the 819-line cameras never achieved anything like the resolution that could theoretically be transmitted by the 819 line system, and for color, France reverted to the same 625 lines as the European CCIR system.

Eventually, the whole of Europe switched to the 625-line PAL standard, once more following Germany's example. Meanwhile in North America the original NTSC 525-line standard from 1941 was retained.

## **5.0 SUMMARY**



Samuel Morse's telegraph in 1844, Alexander Graham Bell's telephone in 1876 and Thomas Edison's light bulb in 1879 were important predecessors to the development of radio. The unit traced the development of radio as well as the challenges faced. Besides, major landmarks in the development were discussed in great detail.

The major people who are contributors to the development were highlighted and discussed. More importantly, the great contributions of the much acclaimed father of radio, Guglielmo Marconi were discussed.

The progress in the development of Television was encouraging because of the people's ever growing interest in the broadcast medium. This unit was able to describe the development of Television the world over. Besides, the unit emphasized the development of colour television which came to consign the black and white television sets into oblivion.

The unit equally mentioned the indelible work of the following Television inventors/pioneer: John Logie Baird, Alan Blumlein, Walter Bruch (PAL television), Alan Archibald Campbell-Swinton, Allen B. DuMont, Philo Taylor Farnsworth, Charles Francis Jenkins Boris Grabovsky, Paul Gottlieb Nipkow, Constantin Perskyi, Boris Rosing, David Sarnoff, Kálmán Tihanyi, Vladimir Zworykin

## **6.0 TUTOR-MARKED ASSIGNMENT**

Compare the development of radio to that of television.

## **7.0 REFERENCES/FURTHER READINGS**

Baran, S.J. (2002). *Introduction to Mass Communication*. New York: McGraw Hill.

Bitner, R. (1989). *Mass Communication: An Introduction*. New Jersey: Prentice Hall.

Sambe J.A. (2005). *Introduction to Mass Communication Practice in Nigeria*. Ibadan: Spectrum Books Limited.



## **UNIT 4 NARROWCAST MEDIA: FILM AND CINEMA, CABLE TELEVISION**

### **CONTENTS**

- 1.0 Introduction
- 2.0 Objectives
- 3.0 Main Content
  - 3.1 The Development and Concept of Film and Cinema
  - 3.2 Types and Functions of Film
  - 3.3 Between Film and Television
  - 3.4 Key Players in Film Production
  - 3.5 The Development and Concept of Cable TV
- 4.0 Conclusion
- 5.0 Summary
- 6.0 Tutor-Marked Assignment
- 7.0 References/Further Readings

### **1.0 INTRODUCTION**

This unit introduces the students to another aspect of the mass media. The unit specifically examines the following:

1. The Film and Cinema
2. Cable Television

### **2.0 OBJECTIVES**

At the end of this unit, you should be able to:

- recount the development and concept of Film
- recount the development and concept of Cinema
- recount the development and concept of Cable TV.

### **3.0 MAIN CONTENT**

#### **3.1 The Concept and Development of Film and Cinema**

What is Film? Film is a medium of communication which combines visual and audio (audiovisual). It contains the recording of a story, acted by people to make it as close to reality as possible. The Collins English Dictionary defines film as a sequence of images of moving objects photographed by a camera providing the optical illusion of continuous movement when projected onto a screen.

History of film is linked up with photography. In 1873 a former California governor, Leland Stanford, hired a well-known photographer, Eadweard Muybridge in order to prove and win a bet that a horse in full gallop had all four feet off the ground. In 1877, Muybridge arranged a series of still camera along a stretch of racetrack. Each still camera took its picture as the horse sprinted. The photographs won Stanford his bet while at the same time, they sparked an idea of motion pictures in Muybridge. This eventually led to the invention of zoopraxiscope by Muybridge. Zoopraxiscope is a machine for projecting slides onto a distant surface.

Muybridge met Thomas Edison in 1888 and was inspired by Muybridge segmental action photographs. William Dickson, a scientist with Edison embarked on the task of developing a better system of filming and came up with Kinetograph-a workable motion picture camera in 1889.

By 1891, Edison built a crude motion picture studio called “Black Maria”, which started the commercial motion picture industry in America. From Black Maria came a series of very short films, which were shown, on a large contraption called a Kinetoscope.

The next advance on film was made by two French men the Lumiere brothers. Auguste and Louis were brothers who worked with their father’s manufacturing photographic plates and film. Using the technology they learnt from Edison’s work, they succeeded in developing a camera much more portable and less cumbersome than Edison’s own that could print and project pictures with a crude yet intermittent motion. The invention was named the cinematographe-a device that both photographed and projected action.

Recognizing the advantage of the cinematographe over his kinetoscope, Edison acquired the patent for an advanced projection developed by U.S. inventor Thomas Armet and Francis Jenkins. The vita scope, as the device was called was premiered in New York City on April 23, 1896, and the American movie business was born.

Following this, a Frenchman, Georges Mèlées began making narrative motion pictures in about 1897. He also added special effects to film making. Mèlées most famous film, “A Trip to Moon”, showed a group of scientist and chorus girls launching a rocket to the moon. Some special effects which Mèlées incorporated in the film include the earth rising on the horizon and a trick photography scene of moon people disappearing in smoke.

Another brilliant contributor was D.W.Griffith. He introduced innovations such as scheduled rehearsals before final shooting and

production based on close adherence to a shooting script. He lavished attention on otherwise ignored aspects of a film such as costume and lighting and used close-ups and other dramatic camera and angles to transmit emotions. He also displayed mastery in his editing techniques of all the films produced by Griffith; he displayed the greatest talent in “The Birth of a Nation” (1914) and in “Tolerance”.

In 1927, sound was introduced to motion pictures. This development made possible new genres like musicals. Actors and Actresses now had to really act and film production became much more complicated and expensive. Film flourished even through the Great depression of the 1930s. Profits were plowed back into bigger productions and lavish sound stages. World War II promoted the boom. Then in the 1950s, film met a new competitor- Television.

### **SELF ASSESSMENT EXERCISE 1**

Establish the connection between film and photography.

### **3.2 Types of Film**

Below are the types of films:

#### **A. COMEDY**

Originally, a comedy is any story that has a happy ending. It can be easily identified by its appearance and plots, and by the deliberate way that these plots are arranged so as to influence the attitude of the audience by generating laughter. The comic characters in the comedy are usually single-minded. They usually possess some peculiar character traits such as gullibility (believing everything, especially obviously impossible and outrageous things), greed (getting into trouble because they can not be satisfied), gluttony or lust (their insatiable appetite leads them into trouble), etc. The real humour lies in the fact that those characters single mindedly pursue their foolish ambitions thereby exposing their inadequacies and foolishness from time to time. They also never suffer psychological or physical pain since they are not even aware that they are doing anything strange.

#### **B. TRAGEDY**

In this genre, the protagonist is confronted by overwhelming dilemmas and also finds himself participating in his own downfall. The image presented by tragedy is that of a human being who is forced to endure the worst, and yet not surrendering to self-defeat, but who finally is subdued and loses out completely. Tragic characters usually possess

admirable traits such as ambition, patience, fortitude, self-confidence, intelligence etc which draw audience affection to them. However, they are eventually confronted by their inadequacies. They are usually shocked at the last moment to realize that they have overestimated themselves. Their tragic overestimation usually includes a character flaw that has been carefully hidden for which they have to account. Their downfall usually affects everyone around them. It is however important to note that tragedies in this sense may not be too common in popular arts such as movies; this is because audience do not wish to regard any situation as hopeless or be burdened with misfortune. Nevertheless, they still exist.

### **C. MELODRAMA**

This is a broad term that is applicable to most movies. This genre stresses elements such as strong emotion, high adventure and self-sacrifice in the service of a noble cause. It usually presents a conflict between good and evil in which good finally triumphs. The characters in a melodrama are easily recognizable by their moral or social commitment to a cause.

### **D. ADVENTURE**

These films are also melodramatic in nature. Among what adventures and melodramas have in common are; action, film climaxing in physical conflict, confrontation between good and evil, experience, persistence etc. Adventure movies may have classic fairy tale structures, or they may follow traditional plots such as that of an originally helpless hero who finally locates and destroys a villain. Adventure heroes are usually full of virtues. Actions in adventure films usually take place in exotic settings such as jungles and unfamiliar or inaccessible parts of cities. A Thriller is not really a genre, rather, it is a characteristic of many adventure as well as other films. Thrillers place emphasis on suspense and fearful anticipation.

### **E. HORROR FILM**

These are films that horrify by invoking experiences that are strange and difficult to explain. They create the feeling of encountering unfamiliar circumstances within familiar environments, with the threat of the unknown destabilizing the security of the known. One of the major characteristics of horror films is the use of low-key lighting so as to intensify the contrast between the seen and the unseen as well as the known and the unknown. They also make use of dissonant music with the intention of creating the feeling of disharmony. Horror films play on the secret fears that lurk at the sub-conscious of their audience. They

also give substance to the nameless fear that dwells in the minds of such audience.

## **F. SCIENCE FICTION**

“Sc fi”, as films in this category are popularly called; also specialize in offering strange and mysterious experiences. They are sometimes sub-genres of horror while at other times, they stand on their own. Their own prominent characteristic is the displacement of time into a technological future where some current tendencies of our culture have become dominant. This may include a situation in which machines become more active in the running of human lives that they (the machines) even attempt to, or actually take over. It may also be in the form of a technological invasion by more advanced cultures (mostly aliens).

## **G. MUSIC VIDEO**

A music video is a film that is predominantly musical in content and which is mostly combined with dances or some sort of movement. A musical, as it is also called, displays the performer’s and composer’s talents through singing and dancing and thereby making the music very satisfying. This type of film has become quite common in modern times. Most music videos are recorded as mini-feature films and some can even be as elaborate as feature films both in cost and in production.

## **H. DOCUMENTARY**

A documentary is a factual film about an event, thing or person, and it presents the facts with little or no fiction. It is a film that captures the various stages of the existence or the process by which something is achieved. This type of film is usually produced for the sole purpose of educating and enlightening its audience. Information in documentaries can be taken at face-value because it is suppose to be the product of a research. Examples of documentaries are films produced on subjects such as wildlife, historical developments, political events etc.

## **I. BIOGRAPHY**

In biographical films, real life experiences are fictionalized so as to provide examples of virtue, bravery, perseverance, commitment etc to the viewers. Biographies permit the audience to enjoy a feeling of intimacy with famous people, and allow them to feel a part of those personalities’ adversity as well as their triumphs.

### 3.2.1 Functions of Film

There is a countless number of functions of film. It must be pointed out that a lot of the functions of a film are subjective, that is, they depend on the individual who is making the personal judgment. Generally, film could be said to be performing the following functions: To educate, persuade or influence and entertain; to enrich our cultural experiences; To provide an escape for the audience and deliver an engaging lesson in history; For raising consciousness about social causes; and For development purposes. However, below are the specific functions of film:

1. **Entertainment:** Film serves as a means of amusing people. This is one of the major functions that a film performs. It gives people the opportunity to explore the lighter side of life which may or may not be realistic. It has been acknowledged that majority of movie audiences are aware that film is make-believe. This simply shows their readiness to take part in a fantasy purely for the sake of entertainment.
2. **Relaxation:** This function is very similar to the previous one. In this case, film serves as a means of easing tension. After the tiring day's or week's work, some people love to watch film so as to ease the tension generated by the formal environment of their place of work.
3. **Catharsis:** Film has a catharsis function because it helps to purge people of negative emotions. It is believed that when people see characters in films undergo a dilemma similar to theirs, by weeping, they release their own pent up emotions.
4. **Psychological Escape:** In this case, film serves as a temporary anesthetic by helping to stop the feeling of pain (emotional or mental stress mostly). By being lost in the world created by film, people are able to temporarily forget about their problems and see that life can still be beautiful.
5. **Creation of Heroes and Role Models:** Whether deliberately or not, film creates role models. It has been observed particularly among children and also some adults that they try to imitate their favourite film heroes. This includes attempting to look, talk or even behave like them.
6. **Mirroring the Society:** Some films can serve as agents of change by mirroring the ills in the society and thereby call attention of their



audiences to them. This creates general awareness and makes people conscious of such issues.

7. Education: Even though this is the least function of most films, it must still be noted that some films educate along with the entertainment function. This is particularly true in the cases of biographies and true life stories.

## **SELF ASSESSMENT EXERCISE 2**

Using examples from Nigerian Nollywood, give your own description of the functions of film.

### **3.3 Between Film and Television**

Film is a sequence of images of moving objects photographed by a camera and providing the optical illusion of continuous movement when projected onto a screen. Television on the other hand is a system or process of producing on a distant screen a series of transient visible images usually accompanied by sound signal. When a camera is focused on an object and it starts to record, electrical signals are converted from optical images by the camera tube, and transmitted by radio waves or cable. A television antenna receives the signals, and then the radio waves are reconverted into optical images by means of a television tube inside a television set.

Film, both as a medium and as an art is very different from television. At this point, we are not interested in proving which is more important; we are only out to highlight their major differences. These two important media are different in the following ways:

1. The process that led to the development of film started in 1873 while that of television started about 11 years after, that is, 1884.
2. Movies are “larger than life” and movie stars are more glamorous than television stars.
3. Film is always pre-recorded while television had only live transmissions until 1951. Pre-recorded programs were introduced when Lucille Ball introduced syndication in 1951 and thereby making rerun possible.
4. Films are largely independent, but networks control what appears on the vast majority of local television stations.
5. Film has cinema audience while television has home audience.

6. Film is more expensive to produce while television production is cheaper.
7. Film contains only one type of program while television offers variety of programs to choose from.
8. Film is simply rated through the box office while television was initially rated through a rather complex process of an audiometer, and later changed to the use of people-meter. Neither the audiometer nor the people-meter accurately served the purpose.

### **SELF ASSESSMENT EXERCISE 3**

Differentiate between home video and cinema.

#### **3.4 Key Players in Film Production**

Film Production is a very big process which involves a lot of people. The major players in the film production process and who will be studied under this topic are as follows:

##### **The Producer**

The producer is the person who initiates the idea of production. This person may continue with his idea himself and become the actual producer or he may collaborate with someone who is a recognized producer. The producer provides for the financing of the project and therefore has power over the production. He is also the chief business executive who is responsible for the film's corporate management which includes business planning, insurance, contracting, hiring etc. Since his money is at stake, a producer most of the time gets involved with the casting process of the film.

##### **The Director**

The Director, who is also known as the artistic director, is in charge of all the film production. He is the film's primary creative authority and is ultimately responsible for virtually everything that appears on the screen. The responsibilities of the director includes; casting (alongside the casting director; if any), coaching actors, arranging blockings, deciding camera shots, overseeing editing etc.

##### **Production Manager**

The production manager has the responsibility of running or managing the entire production. This means that he must ensure that all the

materials that are needed for the production are available. He secures locations whether special or common, sets props, and he makes sure that everybody needed is at the right place at the right time and doing the right thing. The production manager bears the weight of the whole production since he must effectively manage money, materials, equipments and people.

### **Script Writer**

This is the person that creates the screenplay. He may be the originator of the story and wants to either market it or produce it himself. He may also be hired to write a screenplay based on a concept (story idea), a treatment (story outline of several pages or more, with character description), or an adaptation of a novel, play or short story.

### **Cast**

This includes the players and walk-ons who make up the dramatic characters, that is, the stars that most people want to see, and the supporting players that people see whether they notice them or not. It also includes “extras”, who are ordinarily- people and are hired to fill out a street scene, hotel lobby or crowd. There are also the “stunts doubles” for lead players and other “stunts men” and “women” who crash the cars and take the falls, all being coordinated by a stunts coordinator. Dancers and martial artists are also part of the cast and their movements are designed by a choreographer. “Camera doubles” stand in place of stars while cameras are focused and the set lit.

### **Director of Photography**

Or the cinematographer is the artist and technician that is responsible for the photographic look of the film. He is also responsible for the film’s lighting, color values, visual texture and framing. Since all the filming processes cumulate in the final outlook, a bad cinematographer can destroy the whole process. The cinematographer has three principal assistants and they are: the camera operator (who actually operates the camera), the focus- puller and the clapper loader.

### **Production designer**

This artist is also known as the set designer or the art director. Though he, along with the director and the cinematographer are responsible for the look of the film, he is primarily responsible for designing and creating each set according to the budget and expected strategies for each shot. The job of the production designer also includes drawing or commissioning of sketches and architectural drawings of rooms,

buildings, facades, huge flat paintings used as backdrops, or even streets; all of these being subjected to the mood, period, and even dramatic necessity. He also supervises the construction of these sets or the selection and preparation of the “real” location if actual buildings and places are being used.

### **Costume Designer**

This artist selects all the clothing worn by the players in different parts of the film. It is also the responsibility of the designer to design special clothing with due regard to the required action e.g. rough fighting, comic tearing or vigorous dancing. The costumes can be “day-to-day costumes”, “special costumes” or “periodic costumes”.

### **Make-up Artist**

This is the artist that is concerned with the look of the natural body of the actors. Make-up is applied to the natural body of actors so as to either enhance their looks or transform them into the character they are playing. The make-up effect can be straight, character or fantastic.

### **Composer**

The composer, who is also known as the music director composes or selects music to be heard during the film. The music can be classical or popular, symphonic or guitar, traditional or modern. If an existing sound track is needed, the composer makes the arrangement for obtaining the copyright for the music. On the other hand, if a fresh music is needed, he composes the music and arranges for the performance.

### **Sound Director**

This artist has the responsibility of ensuring quality sound output of the film. He works with other professionals such as the sound recorder, boom operator, sound editor, mixer, balancer, dubber, e.t.c.

### **Editor**

The editor handles the editing of the production. He selects good ‘shots’ and ‘takes’ from among the numerous ones taken on location, and arranges them together. He also arranges the shots not according to the sequence by which they were taken, but according to scene in the script.

## **SELF ASSESSMENT EXERCISE 4**

Which of the players in the film production would you consider the most important? Give reasons for your answer.

### **3.5 The Development and Concept of Cable TV**

Cable television was conceived as a way to deliver clear signals to people in remote areas that over-the-air broadcast stations could not reach. John Walson was having trouble selling televisions in 1948 due to the poor reception of signals at these remote areas. He convinced his bosses to let him run wire from a tower he erected on New Boston Mountain to his store. The knowledge of this system by people got him customers to his sets and he wired their homes. This led to the birth of cable television.

The cable Walson used was a twin-lead wire, like cord that connects a lamp to an outlet. To attract more subscribers, he had to offer improved picture quality, made possible by the use of coaxial cable-copper-lead aluminum wire encased in plastic foam insulation, covered by an aluminum outer conductor, and sheathed in plastic. It had more bandwidth than the twin-lead wire and allowed more of the original signal to pass, as well as carrying a greater number of channels.

A further development on this was the development of a signal booster and master antenna which birthed master antennal television (MATV). In 1972, Sterling Manhattan cable (company) launched a new channel, Home Box office (HBO). By 1975, the station started distributing movie channel by satellite, a development that brought antagonism toward cable by over-the-air broadcasters.

There are multi channel services other than cable. Satellite masters antenna (SMATV) employs a satellite dish on top of a building to capture signals and then distributes them throughout that structure. Microwave multi distribution system (MMDS) employs a home microwave receiver to collect signals and pipe them through the houses via internal wiring.

## **4.0 CONCLUSION**

The name "film" originated from the fact that photographic film (also called film stock) has historically been the primary medium for recording and displaying motion pictures. Film is a term that encompasses individual motion pictures, the field of film as an art form, and the motion picture industry. Films are produced by recording

images from the world with cameras, or by creating images using animation techniques or special effects.

Films are cultural artifacts created by specific cultures, which reflect those cultures, and, in turn, affect them. Film is considered to be an important art form, a source of popular entertainment, and a powerful method for educating -or indoctrinating- citizens. The visual elements of cinema give motion pictures a universal power of communication; some movies have become popular worldwide attractions, by using dubbing or subtitles that translate the dialogue.

Traditional films are made up of a series of individual images called frames. When these images are shown rapidly in succession, a viewer has the illusion that motion is occurring. The viewer cannot see the flickering between frames due to an effect known as persistence of vision — whereby the eye retains a visual image for a fraction of a second after the source has been removed. Viewers perceive motion due to a psychological effect called beta movement.

## **5.0 SUMMARY**

The narrowcast media vis –avis, film and cinema are the preoccupation of this unit. The unit has been able to discuss this kind of media in great details. The unit also underscored types of film and the key players in the film production process.

The unit established that the early movies looked to the established forms of drama (comedy, tragedy & musicals) for their themes. Due to the nature of their audiences and the lack of sound, the early films relied on the art of mime.

## **6.0 TUTOR-MARKED ASSIGNMENT**

Enumerate and discuss the challenges facing Nigeria film Industry.

## **7.0 REFERENCES/FURTHER READINGS**

Gollin, R. A. (1998). *Viewers' Guide to Film: Arts, Articles and Issues*. New York: SAGE

Ekwuasi, H. (1987). *Film in Nigeria*. Jos: Nigeria Film Corporation.

Waldron, G. (1953). *The Information Film*. Colombia: Colombia University Press.

## **UNIT 5 THE NEW MEDIA: ONLINE NEWSPAPERS AND MAGAZINES, INTERNET RADIO ETC**

### **CONTENTS**

- 1.0 Introduction
- 2.0 Objectives
- 3.0 Main Content
  - 3.1 The New Media
  - 3.2 The Internet
  - 3.3 Internet Radio
  - 3.4 Online Newspaper
  - 3.5 Online Magazine
- 4.0 Conclusion
- 5.0 Summary
- 6.0 Tutor-Marked Assignment
- 7.0 References/Further Readings

### **1.0 INTRODUCTION**

This unit introduces the students to the New Media, a new aspect of the mass media. The unit specifically examines the following:

1. The internet
2. Internet Radio
3. Online Newspaper
4. Online Magazine

### **2.0 OBJECTIVES**

At the end of this unit, you should be able to:

- explain what the internet is
- have a good understanding of the meaning and concept of internet radio
- clearly explain the concepts of newspapers and magazines.

### **3.0 MAIN CONTENT**

#### **3.1 The New Media**

The New Information and Communication Technologies (ICTs) such as Internet brought to limelight the phenomenon of the new (online) media. The online media is otherwise known as the new media because it is a departure from the old or conventional media of radio, TV, newspaper and magazine. The internet and the World Wide Web (WWW) have

been a significant part of journalism since at least 1994. Hall (2001:2) (as cited in Rodin) notes that Reuters routinely serves 2,700 pages of data every second of every day to a potential market of over 200 million regular Web users. Rudin et al assert that news and information is one of the main reasons people use the Internet, with one survey showing that 40 per cent used the medium to give them more background on a story than had been available through press or broadcasting.

Since the *Daily Telegraph* made its content available online, being the first UK national newspaper that went online, people have become increasingly aware of the need to patronize online journalism and as such, Internet usage at home and at work is also expanding rapidly in the world over, especially in the developing world. According to a survey in 2001, about 40 per cent of all household (in UK) had internet access – an increase of 4 million in just 12 months – and people were spending over 7 hours a week ‘surfing’ the Internet from home. Furthermore, most of those who had taken up the Internet had opted for an unlimited access scheme – which means they can stay online for as long as they want without incurring extra charges (oftel, 2001)

### 3.2 The Internet

Wikipedia defines the Internet as a worldwide, publicly accessible series of interconnected computer networks that transmit data by packet switching using the standard Internet Protocol (IP). It is a "network of networks" that consists of millions of smaller domestic, academic, business, and government networks, which together carry various information and services, such as electronic mail, online chat, file transfer, and the interlinked Web pages and other documents of the World Wide Web.

Succinctly, Internet could be described by four major characteristics. They are:

1. Interactivity, that is, ICTs effective two – way communication.
2. Permanent availability, the new ICTs are available 24 hours a day.
3. Global reach; bridging the geographic distances.
4. Reduced costs for many; relative costs of communication have shrunk to a fraction of previous values.

Dimaggio, Hargittai, Neuman & Robinson (2001) describe the Internet thus:

*Internet can be a telephone: literally, or through e-mail, chat rooms, and other forms of real-time communication between individuals. It can serve*



*as a library: Specialized websites “narrowcast” information to users interested enough to use search engines to find them. It can act as a soapbox: for individuals expressing themselves to e-lists and discussion forums. Or it can operate as a conventional mass medium: Internet service providers like AOL and services like RAM media let providers broadcast information to large users simultaneously. (pp.307-336)*

Kojo, Asiedu and Lu, Song Feng (2003) jointly describe Internet thus:

*The Internet – or Net; is nothing more than a means of transport for digitalized information. But it makes radically new patterns of human communication possible through its speed of transport and the fact that once a link is established it becomes very cheap to send information to one person or to a hundred. The Internet is more of a concept than a thing. It is best thought of as a new means of transport for information - the “tracks” over which actual information services “run”. In the same way, railways made regional and national newspapers possible; the arrival of the Internet makes new information service possible. The Internet allows users to transcend time, distance and old – technology cost constraints. They can form working groups or virtual clubs with people who share their interests, regardless of where they live (P 202).*

The rate of spread of Internet in Africa is equally unprecedented. The Internet doubled in size in 1994 and has done so every year since 1988 and the number of computers connected to the Internet in Africa for example jumped by 36% from July 1988 to January 1999 (Kojo B et al 2003).

Evidently, Internet is the fastest – growing communications medium ever. Millions of people are finding their working lives and increasingly their recreation, changed beyond all recognition. The unprecedented rate of adoption and spread of the new ICTs is not unconnected with the benefits inherent in them. The Internet and related ICTs are being seen as universal remedy of decades for developing World. The new ICTs could deliver better health services, promote political transformation, or generate new economic enterprises. The coming of globalization, free

markets, technological change propelled by the new ICTs are opening up business borders and bridging existing business opportunities.

The Internet has positioned itself as a formidable resource for business information in developing countries. It has opened up people's consciousness to the modern day technique of storing data in different locations and in different formats. Businesses, governments and NGOs are increasingly using the Internet to recruit personnel, save time and expense. With its worldwide scope and role, the Internet permits significant insights into overall market trends and competitive measures. The use of electronic mail minimizes the cost of employing staff, running advertisements, printing and postage costs.

Development experts have posited that the Internet would undoubtedly mean better educated and better – informed people who in turn are more likely to successfully battle poverty and increase productivity so as to have improved economies.

Besides the above mentioned benefits, Internet can equally be beneficial to governments. It can help government agencies and private organizations to communicate with the public, with businesses and with one another. The anytime, anywhere character of the Internet allows information and services from the government, job recruiters/employers to be more available to more people and business with greater convenience and lower cost to customers.

### **3.2.1 Internet and the Web**

The first electronic digital computer was developed during World War II by the British to break the German's secret code. The first full-service electronic computer, introduced in 1946 was ENIAC (Electronic Numerical Integrator and Calculator), introduced by scientist John Mauchly and John Presper Eckert of the Moore school of Electrical Engineering at the University of Pennsylvania. The commercial computers were introduced by the efforts of IBM.

The Internet is in part the product of the military's desire to maintain US defenses after a nuclear attack. It came as a result of the 1957 Soviet Union launch of sputnik, earth's first human constructed satellite, which disputed the supremacy of the US in science and technology. The US research team found answer in decentralization as the key to enabling communication to continue no matter where an attack occurred, and the solution was a network of computer networks- the Internet.

In 1969, Arpanet went online, and became full operational and reliable within one year. Other development soon followed. In 1972, Ray Tomlinson created the first e-mail programme and gave us the

ubiquitous. The term Internet was coined in 1974 by Stanford University's Vinton Cerf and Robert Katin of the U.S. military. In 1979, Steve Bellovin, a graduate student of the University of North Carolina, created Usenet and IBM crested BITNET.

With the development of personal or microcomputers, the Internet became accessible to millions of non- institutional users. Its capabilities include e-mail, mailing list, Usenet, FTP and world wide web (WWW).

### **3.2.2 Internet and the Change in Mass Communication**

The traditional mass media follow a "one to many" model of communication. In other words, one source speaks at one time to many people who constitute a mass audience. Everyone who is tuned to a particular radio station will hear the same commercial and movie goers see the same version of film. The mass media communicate with the public as a mass audience rather than an individual human being.

Internet has given rise to a hybrid model communication. A many to one is a cross between mass broadcasting and interpersonal communication. Large amounts of information are entered into the computer by many different sources and are stored until retrieved by individuals who select only the information they want or need.

In fact, the Internet has incorporated a three dimensional form of information: mass (one to many) interpersonal (one to one) and computing (many to one). But more significant is the emergence of the fourth mode of communication. Just as you have information being entered from many different sources, many individuals too are selecting this information as required or needed by them. So we have the many to many mode of communication.

### **3.2.3 Internet and the Global Village**

The McLuhan's idea of a global village is made possible by the emergence of the Internet. Global village is the idea that the new communication technologies will permit people to become increasingly involved in one another's lives. McLuhan believed that electronic media would permit "the human tribe" to become "one family". However this involvement does not mean harmony, it simply means an exchange of ideas.

The net transforms every user into a potential mass communicator, making freedom of the press a reality for everyone. But freedom has been criticized because individuals are not bound by the kinds of economic and legal restraints that tend to impose responsibility on

larger, commercially oriented media. The major free expression battles in the cyberspace revolve around online pornography, protecting children from inappropriate contact and protecting copyright.

The new communication technologies are touted as democratic because they permit greater citizen involvement. Yet the opposite view is that the commercialization of the Internet will make it as ineffective as more traditional media in serving democratic participation. Besides, it is argued that many people will be shut out of the electronic debate due to technology the information gaps.

### **SELF ASSESSMENT EXERCISE 1**

CNN is located in the US, NTA in Nigeria, Where is the Internet located? Give reasons for your answer.

### **3.3 Internet Radio**

Live Internet radio was born on September 5, 1995, when progressive Networks transmitted the Seattle mariners and New York Yankees game online. Before then, the University of Kansas made history on December. 3, 1994, when its student-run radio station, KJHK-FM, was among the first stations to go live on the Internet. The success stories of some of the radio stations that first established Internet presence quickly spread throughout the radio industry as other stations eagerly connected to the Net.

Some radio stations' websites are merely promotional vehicles for their over-the-air counterparts, with web pages consisting of on-air personality biographies, play lists, audio shorts of new songs, and community calendars. Over-the-air use is slowly decreasing among listeners who use the Internet in the developed countries of the world.

#### **3.3.1 Internet Radio vs Over-The-Air-Radio: Benefits of Internet Radio**

1. Web audio files can be listened to at anytime regardless of when they were first "aired".
2. Netcasts can be listened to from anywhere in the world regardless of the place of origin.
3. Online users can both listen to radio and watch visuals too. Songs, lyrics, news can be seen via text, graphics or video etc.
4. Net casts can be listened to while doing other things. It allows multitasking.

#### **3.2.2 Challenges of Internet Radio**

1. The sound quality of Internet Radio is a formidable barrier to wide spread adoption. The clarity of cybercast depends largely on the type of internet connection used.
2. There is significant delay when downloading audio files.
3. Lacks portability.

## **SELF ASSESSMENT EXERCISE 2**

Mention and describe Internet radio stations known to you.

### **3.4 Online Newspaper**

The phenomenon and features of online newspaper are quite similar to that of webzine. Bittner (1989: 277) explains using a home computer and a modem to couple the telephone to the computer and by dialing the access number, the subscriber is linked with the database, which provides a ‘menu’ of available information, including the list of electronic newspaper. After selecting the newspaper, the subscriber searches an index of categories such as front page, sports, weather and leisure. From these categories, the subscriber selects a given story from coded headlines, and the story then appears in textual form on the video display terminal or home television set.

In a similar manner, the financial implication of running online newspaper is burdensome because of the low commercial patronage. It must be pointed that the first newspaper to go online was the “Columbus Dispatch” on 1<sup>st</sup> July, 1980. It was powered by CompuServe.

Another name for online newspaper is web newspaper. This is because it is newspaper that exists on the World Wide Web or Internet. Modern printed newspapers all over the world are developing and running web newspapers. Going online created more opportunities for newspapers for instance, it allows newspapers to effectively compete with broadcast journalism in presenting breaking news online in a more timely manner than printing allows. The credibility and strong brand recognition of well-established newspapers, and the close relationships they have with advertisers (particularly in the case of local newspapers), are also seen by many in the newspaper industry as strengthening their chances of survival.<sup>[1]</sup> The movement away from the printing process can also help decrease costs.

Not only do they allow for instant updating of news stories in text but also allow equal opportunities for access for disabled groups as well as

adding more interesting features for the viewers to use leading to more interest and more advert opportunities.<sup>[2]</sup> As distinctions between modes of communication become blurred, and as mass communication transforms itself every day with innovation, anyone who has a cellphone on a hike in the woods may now be in instant contact with news and events worldwide.

Online newspapers are not precisely like blogs or forum sites; however, it is not unusual for newspaper reporters and editors to maintain blogs, or for newspapers to add forums to their websites, for easy response from readers. Online newspapers must abide by the same legalities as do their sister publications. Professional journalists have some advantages, as editors are normally aware of the potential for legal problems. The big difference over blog and forum sites as to online newspaper and news sites is that blog and forum sites are not media based websites.

As bloggers and independent citizen-journalists become more prevalent on the web, the potential for an explosion in lawsuits looms as they are not regulated in the same way as it is down to the public and none professional reporters to post stories in most cases. Blog sites can contain misleading information that could be seen as libel, questions regarding negligence or actual malice, or suits regarding invasion. These problems of blog as well as privacy torts such as appropriation, intrusion, private facts and false light were brought up in November 2006 when it hit national headlines in the UK.

### **3.4.1 Online-only Newspapers**

Most existing newspaper organizations with printed/hard copy version of their newspaper also try to have the online version. In other words, they are not purely online, but mixed. With the introduction of the internet, web based newspapers have also started to be produced as online only publications. To be a "Web-Only Newspaper" they must not be part of or have any connection to hard copy formats. To be classed an "Online-Only Newspaper" the paper must also be regularly updated at a regular time and keep to a fixed news format, like a hardcopy newspaper. They must only be published by professional media companies, and fall under national and international press rules and regulations and have 80% or above news content. For example, in 2000 an independent web only newspaper was introduced in the UK called the *Southport Reporter*. It is a weekly regional newspaper that is not produced or run in any format other than soft-copy on the internet by its publishers PCBT Photography.

Unlike blog sites and other news websites it is run as a newspaper and is recognized by media groups in the UK, like the NUJ and/or the IFJ.

Also they fall under the UK's PCC rules. In the US, online-only news sources, such as the Los Gatos Observer and Redding News Review, are not required to update at a regular time or keep to a fixed news format. The difference between a blog and an online newspaper is that the latter is run as a newspaper. One publication, theissue.com, may be seen as a hybrid. TheIssue.com is not a formal newspaper, but also not a blog. The daily publication culls news analysis from across the blogosphere to provide readers with a diversity of opinions and analysis on current events (Wikipedia).

### SELF ASSESSMENT EXERCISE 3

Mention and describe online-only newspapers known to you

### 3.5 Online Magazine

Online magazine is also known as Webzines. This is the soft copy/online version of magazine. In the developed world, webzines have really been adopted, although they started with the production of online editions of their hard copies. Among them are Time and Mother Jones magazines which offer special interactive features not available to their hard copy readers. Production of exclusively online magazines (that is, online magazine that are only available in soft copy) was not in circulation. Until recently, purely online magazines like Slate, Salon and Onion came to being, available at <http://www.slate.com>, [www.salon.com](http://www.salon.com), <http://www.theonion.com>.

Cult of the Dead Cow claims to have published the first **ezine**, starting in 1984, with its **ezine** still in production more than 20 years later. While this claim is hotly debated, **ezines** certainly began in the BBS days of the 1980s. Phrack began publication in 1985 and, unlike Cult of the Dead Cow which publishes articles individually, Phrack published collections of articles in a manner more similar to a print magazine (Wikipedia).

Nigeria has not witnessed a purely online news magazine. What we have at present is the online version of hard copy version of magazines. Examples are online version of *TELL* and *The News* magazines.

One major challenge against online media (online magazines and newspapers) is the struggle to succeed financially such that print media organizations use the hard copy version to cushion the financial burden. Exclusively online magazines have yet to produce a profit, and many industry specialists think it will be a long time before they do. There are special hurdles specific to purely online magazines. First, because web users have become accustomed to free access of sites, webzines have yet

to find a successful means of charging for subscriptions. Slate dropped its plan to do so when faced with a 1997 reader revolt, Salon has instituted a two-tier, both free and subscription, model. Second, as opposed to webzines produced by paper magazines, purely online magazines must generate original content, an expensive undertaking, yet they compose online for readers and advertisers as equals with webzines subsidized by paper magazines (Baron 2004:146)

It must be pointed out that little or no commercial support is available to sustain purely online magazines. Advertisers still prefer paper version to online version. Of the estimated total annual U.S expenditure on advertising (\$200 billion), only \$154 million is spent on online magazine advertising (McNamara, 2000).

#### **SELF ASSESSMENT EXERCISE 4**

Mention and describe online-only magazines known to you

#### **4.0 CONCLUSION**

Unlike the hard copy magazines, online magazine is delivered in an electronic form. An online magazine may be online-only, or may be the online version of an otherwise print-published magazine. Today, most online magazines Internet websites.

An online magazine that caters to a niche or special interest subject matter, i.e. **azine**, is referred to as an **ezone** (usually pronounced "e-zeen"). An **ezone** that appears on the World Wide Web is called a webzine, although webzine may also refer to all online magazines. Other names include cyberzine and hyperzine. For websites that represent an existing print magazine, the web site is usually referred to as "<publication title> Online", whereas an online only magazine is often titled "<publication title> Online Magazine".

#### **5.0 SUMMARY**

This unit has tried to examine the New media, as a new branch of mass communication powered by the new information and communication technologies. Specifically, the Internet, Internet Radio, Online Newspaper and Online Magazine are examined in appreciable details.

The unit established the fact that all these new forms of the media are based on computer and not paper at all. They are manifestation of the prediction of the literary Canadian Scholar Marshall McLuhan.

#### **6.0 TUTOR-MARKED ASSIGNMENT**



Visit this websites ([www.internetvalley.com/tv](http://www.internetvalley.com/tv)) and prepare a two-page report of what is contained therein.

## 7.0 REFERENCES/FURTHER READINGS

Castels M. (1999) *The Rise of Network Society*.

Obe J.O. (2005). *Reporting Diverse Areas: A Concise Text*. Lagos: Standard Mass Concepts Company.

Reddick R. and King E. (2004) *The Online Journalist* [www.cjr.org/Will Gates Crush the Papers?](http://www.cjr.org/Will_Gates_Crush_the_Papers?)

Houston, B. (3<sup>rd</sup> edition), *Computer-Assisted Reporting: a Practical Guide* Bedford/St. Martin's Publisher.

Hall .J. (2001) *Online Journalism – a critical primer*. London Pluto Press.

Oftel K. (2001). Consumers' use of internet: Oftel residential survey Q5 May 2001 <http://www.oftel.org/publications/research/2001> accessed 24 Feb.

Rodin, R. & Ibbotson, T. (2005). *Introduction to Journalism. Essential Techniques and background knowledge*. Amsterdam: Focal Press.

McNamara, T. (2000). *Hard Numbers, now and then*. Columbia Journalism Review P.25).

## MODULE 4      **ADJUNCT AND IMPACT OF THE MASS MEDIA**

Unit 1      Concept of Adjunct of Mass Media, Development and Functions of Public Relations

Unit 2	Concept, Development and Functions of Advertising
Unit 3	Effects of the Mass Media on the Society
Unit 4	Media Effects Theories

## **UNIT 1      CONCEPT OF ADJUNCTS OF MASS MEDIA, DEVELOPMENT AND      FUNCTIONS      OF PUBLIC RELATIONS**

### **CONTENTS**

1.0	Introduction
2.0	Objectives
3.0	Main Content
3.1	Origin/Development of Public Relations
3.2	Definitions of Public Relations
3.3	Philosophy and Perceptions of Public Relations
4.0	Conclusion
5.0	Summary
6.0	Tutor-Marked Assignment
7.0	References/Further Readings

### **1.0      INTRODUCTION**

This unit examines the historical antecedents of Public Relations in the world over, as well as its various definitions. The unit is subdivided as follows:

1. History/Development of Public Relations
2. Definitions of Public Relations
3. Philosophy and Perceptions of Public Relations

### **2.0      OBJECTIVES**

At the end of this unit, you should be able to:

- explain how and why Public Relations started globally
- give the various definitions of Public Relations
- explain the guiding philosophy of Public Relations.

### **3.0      MAIN CONTENT**

#### **3.1      Definition and Basic Facts about Adjuncts of Mass Media**

## Adjuncts of the Mass Media

Adjuncts of the Mass Media refer to additional sources through which the mass media get information. Simply put, they are the additions to the mass media. The most popular of these adjuncts are the news agencies. Hence, we have “News Agency Journalism”. News Agency Journalism is the act of gathering and disseminating world news through the news agencies. These news agencies, which are equally referred to as “extenders”, specialize in the sourcing, processing and distributing of world news and information to other mass media organizations and non-media organizations who are referred to as subscribers. News Agencies are in different categories depending on their coverage and standards. Below are some examples.

Examples of News Agencies include:

Associated Press	<i>AP</i>
United Press International	<i>UPI</i>
Reuters	
Agence France Presse	<i>AFP</i>
Telegrafioie Agentsvo Sovietskoro Soiuza	<i>TASS</i>
News Agency of East Germany	<i>ADV</i>
News Agency of West Germany	<i>DPA</i>
News Agency of Yugoslavia	<i>TANJUG</i>
News Agency of Cuba	<i>Prensalatina</i>
News Agency of Egypt	<i>MENA</i>
News Agency of Japan	<i>Kjodo</i>
News Agency of Indonesia	<i>Antara</i>
News Agency of Spain	<i>EFE</i>
Iraqi New Agency	<i>INA</i>
Indian Press Trust	<i>IPT</i>
Pan African News Agency	<i>PANA</i>
Portuguese News Agency	<i>LUSA</i>
Ghana News Agency	<i>GNA</i>
Kenya News Agency	<i>KNA</i>
Non-Aligned News Pool	<i>NANP</i>
News Agency of Nigeria	<i>NAN</i>

## TYPES OF NEWS AGENCIES

News agencies as we know them today are of three types namely:

1. Transnational or World News Agencies

2. Continental or Regional News Agencies
3. National News agencies.

These agencies are classified according to their levels of operations, areas of coverage and strength of service.

## **1. THE TRANSNATIONAL/WORLD NEWS AGENCIES**

The transnational or world news agencies as the name implies, are the news agencies whose operations are on a world-wide scale. These types of agencies specialize in the gathering, processing and distribution of news on a global level. They maintain correspondents or reporters in almost all the major cities around the world. These correspondents or reporters and the advanced information technologies available to them, help the world news agencies to monitor the whole world like a village – a global village and report events and happenings the minute they happen irrespective of distance, time and magnitude of the events/happenings in question. The news agencies that fall under this type or category include:

- Associated Press (AP) founded in 1948 and owned by newspapers in United States.
- United Press International (UPI) also owned by newspapers in US and a conglomerate of media organizations. The agency was founded 10 year after the establishment of AP.
- Reuters founded in the 19<sup>th</sup> century and owned by the British government
- Agence France Presse (AFP) owned by the French government and founded in the early 19<sup>th</sup> century
- Telegrafrioiie Agentsvo Sovirtskovo Soiuzza (TASS) founded around 1925 and owned by the defunct Union of Soviet Socialist Republic (USSR)

## **2. THE CONTINENTAL/REGIONAL NEWS AGENCIES**

The continental or Regional news agencies operate within their continents or regions. They have correspondents and subscribers in many countries of the world but their services and operations are not spread to every part of the globe. This is the major difference between the world news agencies and the regional news agencies. Whilst the world news agencies maintain correspondents and clients in all the major cities in the world, the regional news agencies only maintain correspondents and clients in their various regions or continents. Examples include:

1. The Non-Aligned News Pool (NANP)

2. Pan – African News Agency (PANA)
3. Indian Press Trust (IPT)
4. Tanjug of Yugoslavia
5. Kyodo of Japan.

### 3. THE NATIONAL NEWS AGENCIES

This type of agency refers to news agencies of individual countries around the world. Almost every country in the world has one form of news agency or the other, e.g. the News Agency of Nigeria. It is this news agency that is referred to as national news agency of that country. However, it must be noted that news agencies like AP, UPI, Reuters and AFP owned by US (AP & UPI), Britain and France respectively do not fall under this category or classification because of their scale or level of operation which go beyond their individual countries. National news agencies only serve their individual countries while the AP, UPI, Reuters and AFP serve the world.

Some good examples of national news agencies are:

1. News Agency of Nigeria (NAN) owned by the Nigerian government.
2. Ghana News Agency (GNA) owned by the Ghanaian government
3. Kenya News Agency (KNA) owned by the Kenyan government
4. Iraqi News Agency (INA) owned by the Iraqi government
5. Middle East News Agency (MENA) owned by the Egyptian government

#### 3.2 Origin/Development of Public Relations

The origin of PR could be traced to the ancient Greeks, who had the idea of the “Public Will” and to the Romans, who used the expression “The voice of the people is the voice of God.” But it is generally believed to have emerged in its modern form in the United States in the late 19<sup>th</sup> and early 20<sup>th</sup> centuries.

Two-prominent names also associated with the emergence of PR are Ivy Better Lee and Edward Bernays. The former originated the concept of PR and first established PR as a vocation. The latter was the first to teach PR in a university faculty.

The initial purpose of PR was to counter scathing criticism of business companies and entrepreneurs by writers, journalist and social critics. The business people were accused of shady deals and a general lack of social responsibility. To counter this criticisms, the business companies hired some of their former critics (the journalist in particular) to help

polish poor company image. The leading journalist hired was Ivy Better Lee, a reporter for the *New York Journal!*

Ivy Lee enjoined his client to re-examine their business policies and practices and to correct wrong business attitudes, in order to create a public opinion and generate a more positive image in the press.

In his pursuit of effective “public relations”, Lee drew up a “declaration of principle”, spelling out the fundamental nature of PR work. Lee was the first person to be called PR councilor. He also co-founded the Parker and Lee PR Agency in 1905.

PR crusade was led by an industrialist in Western Germany. Guster Mevissen was a prominent name. He proposed that public criticism of business companies should be countered by the greatest possible publicity. Another industrialist Alfred Krupp, was also known to take public relations very seriously, when he wrote to his representatives to “conduct your business enterprise in the public”

Taking a cue from the business world. The US Government set up a committee on public information to endeavor by “engineering of consent” to convince America Citizens of the need of America to be involved in the World War1”. The committee was headed by George Creel and also included Ivy Lee and Edward Bernays. Lee and Barneys jointly published a book titled “Crystallizing Public Opinion”. Later, in 1928, Barneys published another book titled “Propaganda”

World War II further reflected the success of the First World War’s role in forming public opinion. An office of war information was established headed by Elmer Davis, a former radio newscaster, to bring public opinion more in line with the heads and pace of government.

Many government agencies from then began to have public relations department and sometimes, consultants were hired to study and interpret public opinion on sensitive issues.

The First World War also helped in the development of public relations as a profession. Many of the first PR professionals organized publicity on behalf of U.S. objectives during World War I. Some of the professionals are: Ivy Lee, Edward Bernays, John Hill, and Carl Byoir. These people got their start with the Committee on Public Information (also known as the Creel Committee). As mentioned earlier, some historians regard Ivy Lee as the first real practitioner of public relations, but Edward Bernays is generally regarded today as the profession's founder.

In describing the origin of the term Public Relations, Bernays commented, "When I came back to the United States, I decided that if you could use propaganda for war, you could certainly use it for peace. And propaganda got to be a bad word because of the Germans using it. So what I did was to try to find some other words, so we found the words Council on Public Relations".

The development of the modern news release (also called a "press release") was credited to Ivy Lee. He espoused a philosophy consistent with what has sometimes been called the "two-way street" approach to public relations, in which PR consists of helping clients listen as well as communicate messages to their publics. In the words of the Public Relations Society of America (PRSA), "Public relations help an organization and its publics adapt mutually to each other." In practice, however, Lee often engaged in one-way propagandizing on behalf of clients despised by the public, including Standard Oil founder John D. Rockefeller. Shortly before his death, the US Congress had been investigating his work on behalf of the controversial Nazi German company IG Farben.

In the 1890s when gender role reversals could be caricatured, the idea of an aggressive woman who also smoked was considered laughable. In 1929, Edward Bernays proved otherwise when he convinced women to smoke in public during an Easter parade in Manhattan as a show of defiance against male domination. The demonstrators were not aware that a tobacco company was behind the publicity stunt.

Bernays was the profession's first theorist. A nephew of Sigmund Freud, Bernays drew many of his ideas from Freud's theories about the irrational, unconscious motives that shape human behaviour. Bernays authored several books, including *Crystallizing Public Opinion* (1923), *Propaganda* (1928), and *The Engineering of Consent* (1947). Bernays saw public relations as an "applied social science" that uses insights from psychology, sociology, and other disciplines to scientifically manage and manipulate the thinking and behavior of an irrational and "herdlike" public. The conscious and intelligent manipulation of the organized habits and opinions of the masses is an important element in democratic society," he wrote in *Propaganda*. "Those who manipulate this unseen mechanism of society constitute an invisible government which is the true ruling power of our country."

In 1929, he orchestrated a legendary publicity stunt aimed at persuading women to take up cigarette smoking, an act that at the time was exclusively equated with men. It was considered unfeminine and inappropriate for women to smoke. Besides the occasional prostitute, virtually no women participated in the act publicly.

Bernays initially consulted psychoanalyst A. A. Brill for advice, Brill told him: "Some women regard cigarettes as symbols of freedom... Smoking is a sublimation of oral eroticism; holding a cigarette in the mouth excites the oral zone. It is perfectly normal for women to want to smoke cigarettes. Further, the first women who smoked probably had an excess of male components and adopted the habit as a masculine act. But today the emancipation of women has suppressed many feminine desires. More women now do the same work as men do.... Cigarettes, which are equated with men, become torches of freedom."

Upon hearing this analysis, Bernays dubbed his PR campaign the: "Torches of Liberty Contingent".

It was in this spirit that Bernays arranged for New York City débutantes to March in that year's Easter Day Parade, defiantly smoking cigarettes as a statement of rebellion against the norms of a male-dominated society. Publicity photos of these beautiful fashion models smoking "Torches of Liberty" were sent to various media outlets and appeared worldwide. As a result, the taboo was dissolved and many women were led to associate the act of smoking with female liberation. Some women went so far as to demand membership in all-male smoking clubs, a highly controversial act at the time.

For his work, Bernays was paid a tidy sum by George Washington Hill, President of the American Tobacco Company.

### **SELF ASSESSMENT EXERCISE 1**

Justify the place of Public Relations 'stunt' during war.

### **3.3 Definitions of Public Relations**

**What are Public Relations?** This question touches on one great challenge that Public Relations has had to confront: it is blessed with so many definitions, a circumstance that has turned out to be a double-edged blessing. On the one hand; the plethora of definitions can always be cited to show what a dynamic discipline – cum - profession Public Relations is. On the other, the plethora of definitions may be partly (but only partly) held responsible for the confusion of the uninitiated about the true essence of Public Relations.

The ignorance or confusion was at one time so much in Nigeria that some funny employer thought a beautiful lady with 'hot' legs should be public relations officer. That was why they had the guts to advertise for a **female "Public Relations officer"** with excellent spoken English, which was unexceptionable – but also with, guess what? Good Legs! All this probably explains why virtually all those who have tried to put



pen to paper on the subject of Public Relations in Nigeria usually begin with a long list of what Public Relations is not. Otto Lerbinger, was constrained to emphasize in some of his disquisitions that PR is not just about seeking good publicity, which is a common perception.

According to Lerbinger, that may have been true when he started teaching and when most people working in PR were former journalists lured by higher paying jobs. But now, says he, PR people, who typically have communication degrees, are involved in marketing, management and policy-making. They also manage crises, which many organizations don't handle well, because they don't listen to their PR people. The hardest part of PR, according to Lerbinger, is to convince those in power to do the smart thing and acknowledge that there is a problem, an impending crisis. 'Often, management won't listen'. Public relations is seen as an interdisciplinary field, encompassing management, economics, psychology, sociology, and politics—that is, besides the mainstream communications disciplines. This was the view espoused by a Nigerian professor of PR/Marketing, Julius Onah, the International Public Relations Association [IPRA] in its Gold Paper No.4 of 1982.

Further, according to Lerbinger, Public Relations persons are trained to listen to people, to seek input, and to study social trends. According to him, PR reflects what happens in the world, and that's what makes it always vital and interesting.

Scholars have a partiality for definitions proffered by groups of experts or associations, in keeping with the age-long adage that two[or more] heads are better than one, provided of course that they are mostly good heads. There is a set of four definitions that comes in handy from that perspective. By far the most succinct and most popular of those group proffered definitions is the one by the British Institute of Public Relations [IPR] which presents public relations as;

*--- the deliberate and sustained effort to establish and maintain goodwill and mutual understanding between an organization and its publics.*

The American Public Relations Association, on its own part, once described public relations as:

*--- the management function which evaluates public attitudes, identifies the policies and procedures of an organization with the public interest, and executes a programme of action to earn public understanding and acceptance.*

The earlier mentioned International Public Relations Associations [IPRA], meeting in the Hague in May 1960, arrived at a definition of PR as:

*--- a management function of a continuing and planned character through which public and private organizations and institutions seek to win and retain the understanding, sympathy and support of those with whom they are or may be concerned, by evaluating public opinion about themselves, in order to correlate as far as possible their own policies and procedures to achieve by planned and widespread information more productive co-operation and more efficient fulfillment of their common interests.*

The final of our four group definitions of Public Relations is the one that has become more or less immortalized as the 'Mexican statement', because it was fashioned at the World Assembly of Public Relations Associations in Mexico in 1978. It projects public relations as;

*--- the art and science of analysing trends, predicting their consequences, counselling organizational leaders, and implementing planned programmes which will serve both an organization's and [its] publics' interests.*

Much as scholars prefer definitions forged by groups to those emanating from individual reflections, one must at the same time acknowledge the efforts of a British expert, Dr. Rex Harlow who, presumably eager to put some restraint on the label of extant definitions, is reputed to have studied 472 definitions and interviewed 84 PR professionals, mostly veterans, to arrive at his own definition which, as you must have rightly guessed, was for the purpose of his Ph.D thesis. At the end, he states that;

*Public relations is the distinctive management function which helps to establish and maintain mutual lines of communication, acceptance and co-operation between an organization and its publics; involves the management of problems or issues; helps management to keep informed on and responsive to public opinion; defines and emphasizes the responsibility of management to serve the public interest; helps management to keep abreast of and effectively utilize change, serving as an early warning system to help anticipate trends; and uses research and sound ethical communication techniques as its principal tools.*

From all these group 'Rex Harlow came up with certain glaring facts about the principal preoccupations and attributes of public relations. Some, of which are:

1. Public Relations is preoccupied with establishing and maintaining mutual understanding and goodwill between an organization and its public, a government and its subjects, a ruler and the ruled, a statesman and his compatriots, etc.
2. Public Relations is largely a communication discipline or profession with its tentacles in various other branches of knowledge or, put simply, it is an interdisciplinary field.
3. Public Relations is at once a science and an art.
4. Public Relations is primarily a management function, even though-like other management functions-it has its technician operations.
5. Public Relations activities are planned and deliberate, not whimsical or fortuitous.
6. Public Relations activities are sustained or continuous, not *ad hoc* or tied to the expedient: in other words, they help to build a constant reservoir of goodwill which we can readily tap in times of need.
7. Public Relations is essentially proactive and predictive, though it is often compelled to be reactive and backward-looking.
8. Public Relations thrives on dialogue and persuasion but is antithetical to social monologue and whimsical.

The following specifically clarify PR:

1. PR is deliberate – the activity is purposeful and intentional
2. PR is planned
3. PR is a process
4. In PR, corporate performance speaks louder than company's voice
5. PR involves the mutual interests of an organisation and its public
6. PR is a management function
7. PR is two- way communication

### **Public Relations Activities**

1. Publicity – the practice of getting media coverage for the client.
2. Communication; PR involve communicating with target public and advising clients in their interaction with them.

3. Public Affairs: It includes interacting with officials and leaders of the various power centres with whom a client must deal
4. Government Relations: working with government agencies. E.g. lobbying-interacting to influence government regulations and agents.
5. Community Relations. It focuses on the communities in which the organization exist
6. Minority Relations: targeting specific racial minorities.
7. Financial P.R: Involves communication between companies and their shareholders, financial community and the public.
8. Industrial Relations. Involves interaction with other companies in line of business, both competitors and supplier
9. Press Agency: Means attracting attention to the client, usually through planning or staging some activity.
10. Promotion: It involves creating support or goodwill for the client as opposed attention getting of press agency.
11. Media Relations: Maintaining good relationship with media professionals, as well as understanding their peculiarities.
12. Issue Management: Involves campaign to shape opinion on a specific issue.
13. Crises Management: Resolving organization crises.
14. Propaganda: The generation of more or less automatic responses to given symbols.
15. Advertising: The use of controlled communication to build an image or to motivate action.

## **SELF ASSESSMENT EXERCISE 2**

Take a look at the definitions of Public Relations described above, coin your definition.

### **3.4 Philosophy and Perceptions of Public Relations**

#### **3.4.1 Perceptions and Misconception of Public Relations**

Public Relations had often been referred to in less than endearing terms. But that should not be unduly surprising. In the United States where modern Public Relations was more or less inaugurated (as a profession, by Ivy Ledbetter Lee, and as a University discipline, by Edward Barnays roughly a century ago (precisely in 1919 and 1923 respectively), the general level of contemporary understanding of the essence of the Public Relations discipline and profession is scarcely anything to write home

about. Thus, distinguished Professor of Public relations, Otto Lerbinger of Boston University College of Communication, had this to say during his pre-retirement engagements in the summer of 2004.

*I've been subject to abuse for fifty years. I'm so used to it that it doesn't bother me any more. If there are stereotypes attached, then that's bad. But we're fighting by trying to create greater understanding of what PR really is.*

Otto Lerbinger, who had taught PR since 1954, had earlier recounted his gratifying experiences in teaching and counselling on Public Relations including the satisfactions of seeing his products put to successful practice what they had been taught on “how to extinguish fires”, and more important, “how to prevent them from starting”. It was after that that he conceded “the other side of the story”, rattling off pejorative terms often associated with his life’s work. Sometimes, he says, he wasn’t even sure he should keep the title, “Professor of Public Relations”, since to some skeptics, that’s akin to being a “Professor of puffery”. But he decided he should do what he does best: teach people about PR.

### **3.4.2 Layman’s Notions of PR**

The perception of PR from the layman’s angle steth not totally incorrect, they are individually incomplete views of PR. They are unprofessional or amateur concepts of PR. Such views are that PR is synonymous with the following:

1. Courtesy
2. Protocol
3. Goodwill
4. Friendship
5. Fine appearance
6. Free gifts
7. Annual Parties
8. Cash Bonuses etc.

### **3.4.3 Branches of PR**

PR has the following specialisations:

4. Employee Relations
5. Industrial PR
6. Financial PR
7. Community Relations
8. Customer Relations
9. Press Relations

10. Government Relations

11. International PR

### 3.4.4 Purpose and Philosophy of Public Relations

The purpose of PR in an organisation is of pivotal importance to the continued existence of that organisation. PR can make important contributions to forming an organisation's ideas about itself- what it should do and what society wants and expects from it. Charles Steinberg describes this aspect of PR as the "structuring of company philosophy and carrying out of that philosophy in practice so that what the institution says is not at variance with what it does".

The duties of PR practitioners are basically to assimilate and communicate information between an organisation and its environment. PR helps our complex, pluralistic society to reach decisions and function more effectively by contributing to mutual understanding among groups and institutions. It serves to bring the public and public policies into harmony.

Succinctly, PR is hinged on humanistic ideology, a social philosophy that places the broad interests of the people first in all matters pertaining to the conducts or operations of an organisation. This philosophy equally holds that an institution's primary function is to serve the basic needs of its public, who are dependent upon it for employment, income, wages, products and services as well as social goods and spiritual satisfaction.

The following are most specific principles of PR.

1. PR deals with facts, not fiction
2. PR is a public service instead of a personal endeavour
3. PRO is not a *yes- man*
4. Honesty is the best policy in PR
5. PRO is a mediator
6. PR is not a guessing game
7. Institution is not enough in PR
8. PR is an inter-disciplinary or multi-disciplinary field
9. PRO is a corporate Vigilante
10. A PRO is as good as his image

### SELF ASSESSMENT EXERCISE 3

Many people know more of what Public Relations is not than what it is. Discuss

#### **4.0 CONCLUSION**

The understanding of the concept of Public Relations has not been really there, especially, among the so called practitioners who take Public Relations to be something else. To them, giving gratification or bribe is Public Relations. The concept of Public Relations has been thoroughly misused with the appellation: PR. The misconceptions about Public Relations have threatened to undermine its very essence as well as diluting its guiding philosophies on the minds of the people.

#### **5.0 SUMMARY**

The beginning and concept of Public Relations have been discussed in appreciable details in this unit. The unit started from the origin of Public Relations and the connection the First World War 1 had with it. The unit pointed out that layman's notions of Public Relations are unprofessional or amateur concepts of Public Relations. Such views according to the unit are synonymous with Courtesy, Protocol, Goodwill, Friendship, Fine appearance, Free gifts, Annual Parties, Cash Bonuses etc.

The unit also enumerated the branches of Public Relations to include: Employee relations, Industrial PR, Financial PR, Community Relations, Customer Relations, Press Relations, Government Relations, International PR.

Having discussed thoroughly the various definitions of Public Relations, the unit enumerated the most specific principles of PR to include: PR deals with facts, not fiction; PR is a public service instead of a personal endeavour; PRO is not a *yes-man*; Honesty is the best policy in PR; PRO is a mediator; PR is not a guessing game; Institution is not enough in PR; PR is an inter-disciplinary or multi-disciplinary field; A PRO is a corporate Vigilante; PRO is as good as his image

#### **6.0 TUTOR-MARKED ASSIGNMENT**

Public Relations is not recognised as a management function in most Nigerian organizations. Discuss the validity of this statement.

#### **7.0 REFERENCES/FURTHER READINGS**

Cutlip, Scott M. Centre, Allen H; and Broom, Glen M. (1999). *Effective Public Relations*. News Jersey: prentice Hall, Inc.

Jefkins, F. (1980). *Effective Public Relations Planning*. Britain: Foto Direct Printers.

Black, S. (1989). *Introduction to Public Relations*. London: Modino Press.



## **UNIT 2      CONCEPT, DEVELOPMENT AND FUNCTIONS OF ADVERTISING**

### **CONTENTS**

- 1.0 Introduction
- 2.0 Objectives
- 3.0 Main Content
  - 3.1 Origin/Development of Advertising
  - 3.2 Definitions of Advertising
  - 3.3 Functions of Advertising
- 4.0 Conclusion
- 5.0 Summary
- 6.0 Tutor-Marked Assignment
- 7.0 References/Further Readings

### **1.0 INTRODUCTION**

This unit examines the historical antecedents of Advertising in the world over, as well as its various definitions. The unit is subdivided as follows:

1. History/development of Advertising
2. Definitions of Advertising
3. Functions of Advertising

### **2.0 OBJECTIVES**

At the end of this unit, you should be able to:

- discuss the origin of advertising
- give at least three definitions of advertising.

### **3.0 MAIN CONTENT**

Advertising is an adjunct of the mass media. It has to do with commercial persuasion. All advertising contains both information and persuasion in varying degree. The classified advertisements in the daily newspaper are almost information. Their primary intention is to advise readers of the availability of products-telling where, when and for how much. The audience either wants it or they do not (Black et al 1998:296).

### 3.1 Origin and Development of Advertising

Ancient forms of advertisement existed before the emergence of newspaper. There were critics who advertised their product through oral norms in ancient Rome, Medieval England, and America and in Africa. Signs and symbols were also used to advertise. Graffiti on the walls of Pompeii and the stone obelisks of ancient Egypt give evidence of early sales promotion.

Trademark and brand system differentiation began in the middle ages. Marks were developed to identify the makers of many goods while the medieval guild controlled the quality of such goods, thus making the mark a great asset.

The emergence of newspaper in 1620 gave advertising a medium to grow. The date of the first newspaper advert is yet to be known but Henry Sampson cites in advertising that appeared in 1650 in several editions of the “proceeding in parliament”.

In the early American colonies, the Boston newsletter appeared in 1704. It attempted to find a buyer or rents for an estate in Oyster Bay Long Island. In 1729, Benjamin Franklin began publishing his newspaper the *Pennsylvania Gazette*, and he was often considered as the father of American advertising. Franklin made important innovation in newspaper advertising. He was the first American to use advertising illustration. He was a copywriter, an advertising manager, salesman, publisher and editor. His most famous piece of advertising copy was the Pennsylvania fireplace. {The Franklin Stove}

The Egyptians played a remarkable role in the development of advertising when they used papyrus to create sales messages and wall posters, while lost-and-found advertising on papyrus was common in Ancient Greece and Ancient Rome. Wall or rock painting for commercial advertising is another manifestation of an ancient advertising form, which is present to this day in many parts of Asia, Africa, and South America.

As far back as 4000BCE, the Indians were involved in ancient advertising in form of wall painting as exhibited by the popular Indian rock-art paintings. During the mid 16<sup>th</sup> century, advertising expanded to include handbills. In the 17th century, advertisements started to appear in weekly newspapers in England. These early print advertisements were used mainly to promote books and newspapers, which became increasingly affordable due to the printing press; and medicines, which were increasingly sought after as disease ravaged Europe. However,

false advertising and so-called "quack" advertisements became a problem, which ushered in the regulation of advertising content.

The expansion in the world economy equally led to accelerated growth in advertising. In the United States of America, classified advertisements became popular, filling pages of newspapers with small print messages promoting various goods. The success of this advertising format eventually led to the growth of mail-order advertising.

In 1841, Volney Palmer, a Boston based advertising agency was the first, advertising agency to be established and the first to charge a commission on ads at 25% commission paid by newspaper publishers to sell space to advertisers. At first, agencies were brokers for advertisement space in newspapers. N. W. Ayer & Son was the first full-service agency to assume responsibility for advertising content. N.W. Ayer opened in 1875, and was located in Philadelphia.

Women too, joined the advertising career and since women were responsible for most of the purchasing done in their household. Advertisers and agencies recognised the value of women's insight during the creative process. In fact, the first American advertising to use a sexual sell was created by a woman – for a soap product. Although tame by today's standards, the advertisement featured a couple with the message "The skin you love to touch".

When radio stations began broadcasting in the early 1920s, the programmes were however nearly exploded. This was so because the first radio stations were established by radio equipment manufacturers and retailers who offered programmes in order to sell more radios to consumers. As time passed, many non-profit organizations followed suit in setting up their own radio stations, and included: schools, clubs and civic groups.

When the practice of sponsoring programmes was popularised, each individual radio programme was usually sponsored by a single business in exchange for a brief mention of the business' name at the beginning and end of the sponsored shows. However, radio station owners soon realised they could earn more money by selling sponsorship rights in small time allocations to multiple businesses throughout their radio station's broadcasts, rather than selling the sponsorship rights to single businesses per show. This practice was carried over to television in the late 1940s and early 1950s.

In the early 1950s, the Dumont television network began the modern trend of selling advertisement time to multiple sponsors. Previously, Dumont had trouble finding sponsors for many of their programme and

compensated by selling smaller blocks of advertising time to several businesses. This eventually became the norm for the commercial television industry in the United States. However, it was still a common practice to have single sponsor shows, such as the U.S. Steel Hour. In some instances, the sponsors exercised great control over the content of the show - up to and including having one's advertising agency actually writing the show. The single sponsor model is much less prevalent now, a notable exception being the Hallmark Hall of Fame.

The 1960s saw advertising transform into a modern, more scientific approach in which creativity was allowed to shine, producing unexpected messages that made advertisements more tempting to consumers' eyes. The Volkswagen ad campaign--featuring such headlines as "Think Small" and "Lemon" (which were used to describe the appearance of the car)--ushered in the era of modern advertising by promoting a "position" or "unique selling proposition" designed to associate each brand with a specific idea in the reader or viewer's mind. This period of American advertising is called the Creative Revolution and its poster boy was Bill Bernbach who helped create the revolutionary Volkswagen ads among others. Some of the most creative and long-standing American advertising dates to this incredibly creative period.

The late 1980s and early 1990s saw the introduction of cable television and particularly MTV. Pioneering the concept of the music video, MTV ushered in a new type of advertising: the consumer tunes in *for* the advertising message, rather than it being a byproduct or afterthought. As cable and satellite television became increasingly prevalent, specialty channels emerged, including channels entirely devoted to advertising, such as QVC, Home Shopping Network, and Shop TV.

Marketing through the Internet opened new frontiers for advertisers and contributed to the "dot-com" boom of the 1990s. Entire corporations operated solely on advertising revenue, offering everything from coupons to free Internet access. At the turn of the 21st century, the search engine Google revolutionized online advertising by emphasizing contextually relevant, unobtrusive ads intended to help, rather than inundate, users. This has led to a plethora of similar efforts and an increasing trend of interactive advertising.

The share of advertising spending relative to GDP has changed little across large changes in media. For example, in the U.S. in 1925, the main advertising media were newspapers, magazines, signs on streetcars, and outdoor posters. Advertising spending as a share of GDP was about 2.9%. By 1998, television and radio had become major

advertising media. Nonetheless, advertising spending as a share of GDP was slightly lower -- about 2.4%.

A recent advertising innovation is "guerrilla promotions", which involve unusual approaches such as staged encounters in public places, giveaways of products such as cars that are covered with brand messages, and interactive advertising where the viewer can respond to become part of the advertising message. This reflects an increasing trend of interactive and "embedded" ads, such as via product placement, having consumers vote through text messages, and various innovations utilizing social networking sites (e.g. MySpace).

Paul McManus, the Creative Director of TBWA\Europe in the late 90's summed up advertising as being "...all about understanding. Understanding of the brand, the product or the service being offered and understanding of the people (their hopes and fears and needs) who are going to interact with it. Great advertising is the creative expression of that understanding."

### 3.1.1 Forces behind the Growth of Modern Advertising

The forces are:

1. Technological development- mass production, mass communication and mass marketing.
- 2) Growth in productivity per worker.
- 3) Increase in disposable income
- 4) Growth of the middle class- creating more advertising audience.
- 5) Growth of transportation- allows distribution.
- 6) Increase in education
- 7) Decline of personal selling
- 8) Growth of specialized advertising organization
- 9) Growth of brands and variety of merchandise.
- 10) Growth in use of research.

### SELF ASSESSMENT EXERCISE 1

What are the roles *Iwe Iroyin* played in the development of advertising in Nigeria?

### 3.2 Definitions of Advertising

Advertising is derived from the latin word, *ad vertere* which means "to turn the mind toward". What this means is that advertising in itself can only predispose, or tips the scales. Advertising does not and cannot sell anything. (Black et al 1998:296)

Simply put, advertising is a paid form of communicating a message by the use of various media. It is persuasive, informative, and designed to influence purchasing behavior or thought patterns. One important thing about this definition is that **Advertising** is paid and not free. It could also be defined as a one-way communication through a medium in which the sponsor is identified and the message is controlled by the sponsor. Every major medium is used to deliver these messages, including: television, radio, movies, magazines, newspapers, video games, the Internet.

The American Marketing Association (AMA) defines advertising as “any paid form of nonpersonal presentation and promotion of ideas, goods or services by an identified sponsor.” This presupposes the fact that advertising is openly and overtly subsidized information and persuasion, and its task is to present and promote far more than the merchandise.

One needs to point out that advertising cannot impose or force people to accept its message. In other words, the effectiveness of any advertising is subject to audience receptive ability. Advertising is controlled, identifiable information and persuasion by means of mass communication.

Unlike other media where the source is not the gatekeeper, the advertiser is the gatekeeper here. Whoever pays the bills to place the advertising in the edit exercises control over how those messages are to appear. When someone sends a public relations release to newspaper, the editors and reporters become the gatekeepers. They determine whether and how the message looks, what it says, when and where it will appear and who is likely to see it. In this sense, commercial advertising is more open and above board than public relations and much more so than its totalitarian counterpart, propaganda, in which more often than not persuasion is masked as news or its sources are perverted or hidden (Black et al 1998:296)

### **3.2.1 Advertising Agency**

The advertising Agency is a mediator between the advertisers and the mass media. The advertisers could be the manufacturer or distributors of particular products. The advertising Agency represents the two parties involved very well by serving their interest well. The major function of advertising Agency could be summed up as: client liason, creativity, production, placement and housekeeping.

## **Functions of the advertising Agency**

1. Planning
2. Client service
3. Creative service
4. Advert placement
5. Research.
6. Sales promotions
7. Public relations

## **Top Ten World Advertising Agencies**

Source: [http://www.adage.com/international/world\\_brands](http://www.adage.com/international/world_brands), February 12, 2002.

McCann-Erickson Worldwide; DDB Worldwide; Grey advertising; Ogilvy & Mather; Worldwide; EURO RSCG Worldwide; J. Walter Thompson Co.; BBDO Worldwide; Y & R advertising; Publicis Communication; D'Arcy Masius Benton & Bowles; Agency Markets Clients.

## **SELF ASSESSMENT EXERCISE 2**

Explain the 'Advertiser as gatekeeper rather the editors' in advertising.

### **3.3 Functions of Advertising**

The primary function of advertisement is to help companies produce larger sales, less supply, and a possibility to introduce new products etc. It helps stores with faster turnover of old goods and it enables the use of media as an important source of funds for a normal business. It enables a more qualitative choice between products to consumers. And it also helps society in general because it promotes economic development, encourages competition in quality and so adjusts products to be equal on an international market.

One important use of advertising is that it reduces the unit cost of a product. Another function of advertising is to increase sales volume of products and establish product distribution in a new locality.

Advertising can also reduce production costs in a few industries by increasing the scales of operations. Increased demand created by advertising brings about a reduction of cost per unit as a consequence of the lower costs made possible by mass production process.

Another function of advertising is that it enhances the quality of products. Advertisers are looking for unique feature and characteristics of a product, or the quality edge the product has over other products. This unique feature is what the advertiser would use to package the advertisement messages.

Advertising compels ever-increasing qualitative superiority of product on the management of all companies. The advertiser with a product characteristic which can be stressed may achieve the steady patronage of customers who are won over to the product. This should result in stabilizing a share of the total market for the product (Ajai 2005:54).

### **Don'ts of Advertising**

Below are the don'ts of advertising:

- Advertising must not contain anything that is contrary to the law and must not leave out anything that the law requires.
- Advertising must not contain anything that insults the public in terms of dominant respectability rules. It must also not be contrary to self-evident equality between genders or show a man, a woman or a child in an offensive way. Nudity and sexual implication that shock public or draw attention as well as pointless connection with the product is not acceptable. When nudity and sexual implication are connected with the message, it should not offend good taste.
- Advertising must not be so framed as to abuse the consumer's trust, exploit their lack of experience or knowledge and to manipulate them.
- Technical descriptions, claims and comparisons which are published in advertisements must be proven. If there are unusual claims that are not generally known, advertisers and advertising agencies must take all responsibility for it.
- Messages must not contain claims or visual images that directly or indirectly mislead the consumer about the purpose of the product or about the advertiser.
- Lies or exaggerations which try to amuse or draw attention are allowed only if this purpose is clear and not if it's a fact that must be accepted as one.



### **SELF ASSESSMENT EXERCISE 3**

What are the dysfunctions of advertising?

#### **4.0 CONCLUSION**

Advertising is faced with controversy. It is both condemned and praised in that while others see advertising as the driver of business as it reduces the unit cost of a product by creating mass demand, others in the opposing side say that advertising is wasteful; that consumers pay more for a product that is advertised than they would, if it were not.

Advertising gives the company the desire to improve the quality of its products and services and makes a company to engage in continuous product research and development

#### **5.0 SUMMARY**

The place of advertising in the economy is underscored in this unit. The unit which started with the historical antecedent of advertising in the world over, equally looked at definitions of advertising. Besides, the unit briefly discussed the mediator in advertising business, otherwise known as the advertising Agency which function include: Planning, client service, creative service, advert placement, Research., Sales promotions and Public relations

#### **6.0 TUTOR-MARKED ASSIGNMENT**

Advertisement is too much with us; It lies and misleads. Make a solid case for or against this statement.

#### **7.0 REFERENCES/FURTHER READINGS**

- Ajai, S.O. (2005). *Public Relations in Marketing Education*. Lagos: Pumark Educational Publishers.
- Doghudje, C. A. (1985). *Advertising in Nigerian Perspective*. Lagos: Zus Bureau.
- Jefklins, F. (1982). *Introduction to Marketing Advertising and Public Relations*. London: Macmillan Publishers Ltd.

## **UNIT 3 EFFECTS OF THE MASS MEDIA ON THE SOCIETY**

### **CONTENTS**

- 1.0 Introduction
- 2.0 Objectives
- 3.0 Main Content
  - 3.1 Definitions of Media Effect
  - 3.2 Levels of Assessment of Media Effects
- 4.0 Conclusion
- 5.0 Summary
- 6.0 Tutor-Marked Assignment
- 7.0 References/Further Readings

### **1.0 INTRODUCTION**

This unit examines the effect of media on the society. The unit is subdivided as follows:

1. Overview of Media Effects
2. Definitions of Media Effect
3. Levels of Assessment of Media Effects

### **2.0 OBJECTIVES**

At the end of this unit, you should be able to:

- describe the effects of media on the society
- understand the definition media effects
- identify the levels of assessment of Media Effects.

### **3.0 MAIN CONTENT**

#### **3.1 Definitions of Media Effect**

To better understand the concept of media effects, let us examine the definitions below:

McQuail (1977) defines media effects as any of the consequences of mass media operation, whether intended or not, that has effectiveness and the capacity to achieve given objectives.

Black et al (1995) observes “the term media effects not only refer to the consequences or impacts of media use on individuals, society and culture; media effects also are rather well-defined area of scholarly

inquiry that examines the impact of media”. Black summarises certain rules or conventions about what must occur before something is considered to be true media effect. They are:

1. the presumed cause (e.g. a person watches a lot of violence on television or in films) and the presumed effects (e.g. a person becomes more aggressive) most covary, change together, in some verifiable way;
2. the presumed cause (e.g. viewing violence) must precede in time the presumed effect (e.g. engaging in aggression); and
3. rival causes and explanations for these other causes (e.g. living in a volatile environment) must be controlled for and/or eliminated.

Media effects mean different things to many people. To some, it is just about the impact of the mass media message on the audience. Even at that, some communication academics believe that particular parts of the media message must be contextualized. In other words, some academics talk about media effects to mean the impact of particular content of the mass media message. For instance, the impact of watching pornography on audience is propensity to rape. In this case, it is the contents of the media message that produce the impact.

To other academics, it is the medium through which the message passes through that matter. These academics are more concerned about the consequences of using a medium as a totality, relatively independent of the nature or content of its messages. They are particular about the effect that devoting a great deal of time to watching television might have on literacy by displacing time that otherwise might be spent on reading.

In the same vein, some academics are concerned with the impact of particular media message conventions or public notions about a media message. For instance, the general convention is that video games may be addictive for youngsters because they are so fast paced and use so many “orienting devices” that they may control children’s attention.

Focusing on the specific context in which potential effect occur is another concern of effect by researchers which they termed media context effects. For instance, an assessment of the impact of settings and situations in which media are used, such as the impact on learning of watching television or listening to rock music while doing homework.

## **SELF ASSESSMENT EXERCISE 1**

From your limited experience, define media effects.

### **Levels of Assessment of Media Effects**

Generally, media effect could be assessed at many different levels. They include at:

1. individual level
2. family level
3. reference group
4. community group
5. societal group and
6. cultural group

One needs to point out that different approaches to the assessment of the impact of the media can be used. At the individual level, for instance, scholars might be concerned with media effects on attitudes, beliefs or behaviours, or examination of media effects on perceptions of reality, on level of anxiety, on moral judgement, on predispositions to commit a crime, and on many other dimensions of the way we think, feel or act. (Black et al 1995: 36).

Black and his group also noted that “some scholars are more concerned with the short-term or transitory effects of media; others strive to determine whether the media have more durable or long term effects. Sometimes, the positive, beneficial or prosocial effects of media are examined, but more often, concerns are with the negative, detrimental or anti-social consequences of using media”. The authors noted further: “some people examine media effects simply for the purpose of better understanding the roles and consequences of media in the society. Others examine media effect in order to know how to utilize media more effectively to achieve specific goals. Still, others consider media impact in order to administer or regulate media or to better formulate public policy regarding media”.

### **SELF ASSESSMENT EXERCISE 2**

Which of the levels above do you think media effects could be assessed the most?

## **4.0 CONCLUSION**

This unit has been able to show that the mass media alone should not be blamed or praised for any disruption or betterment in the social communication process. Rather, the unit maintains that both the media

and the society at large should be responsible for such alteration in the social process.

Those who tend to hold the mass media solely responsible are those who exaggerate the influence of media and center widespread public concern on negative media effects. This is because they thought that it was possible to study effects more objectively than media uses could be studied. They chose to focus their efforts on developing what they thought would be definitive, powerful 'explanations for the consequences' of media use. They didn't see as much purpose or value in describing and cataloguing people's subjective reasons' for using media (Baran & Davies 2003: 258).

The position of this unit is that such effects research is one sided because media cannot serve their intended function unless people make certain uses of their content. Mass media can only transmit any information successfully, only if enough audience members are willing and able to make certain uses of the content. In other words, without the society, which responds or interacts with the mass media, the mass media cannot single-handedly alter the social process. The position here subscribes to the uses and gratifications approach and sharply contradicts that of the effects theories.

One needs to point out, however, that rather than taking a one sided position, that is, 'uses' against 'effects', it is worthwhile to consider the new research directions which seek to harmonise the 'uses and 'effects' approaches. Windahl (1981) argued that a merger of 'uses and gratification' and the 'effects' traditions was overdue and proposed what he called a 'uses and effects' model that viewed the product of the use of media content as 'consequences' (cited in Baran & Davies) 2003: 268)

Blumer (1979), while presenting his ideas on how the uses and gratifications effect approaches could be harmonized writes:

*How might propositions about media effects be generated from... gratifications? First, we may postulate that cognitive motivation will facilitate information gain... Second, media consumption for purposes of diversion and escape will favour audience acceptance of perceptions of social situations in line with portrayals frequently found in entertainment materials... Third, involvement in media materials for personal identity reasons is likely to promote reinforcement effects.*

In essence, while one could align oneself with one position against the other, it appeals to intellectual reasoning to pursue the new direction

which Windhal refers to as ‘consequences’. With these, orientations into the role of the media in the society would be harmonized.

## **5.0 SUMMARY**

This unit has been able to establish the effect of mass media in the society. It looked specifically at what the media do to people and what people do with the media. The unit also examined the different levels of assessment of media effects concept.

## **6.0 TUTOR–MARKED ASSIGNMENT**

Most people believe that the media is to be blamed for the disruption in the society. Do you agree? Give reasons.

## **7.0 REFERENCES/FURTHER READINGS**

Baran, S.J. (2002). *Introduction to Mass Communication*. New York: McGraw Hill.

Bitner, R. (1989). *Mass Communication: An Introduction*. New Jersey: Prentice Hall.

Sambe J.A. (2005). *Introduction to Mass Communication Practice in Nigeria*. Ibadan: Spectrum Books Limited.

## **UNIT 4    MEDIA EFFECTS THEORIES**

### **CONTENTS**

- 1.0 Introduction
- 2.0 Objectives
- 3.0 Main Content
  - 3.1 Media Effect Debate/issues
  - 3.2 Limited Effects Tradition
  - 3.3 Powerful Effect tradition
  - 3.4 Uses and Gratification Concept
  - 3.5 Cultural Effects Tradition
- 4.0 Conclusion
- 5.0 Summary
- 6.0 Tutor-Marked Assignment
- 7.0 References/Further Readings

### **1.0 INTRODUCTION**

This unit examines different traditions/paradigms that explain the effects of the media on people and the society. The unit is subdivided as follows:

- 1. Media Effect Debate/issues
- 2. Limited effects tradition
- 3. Powerful Effect tradition
- 4. Uses and gratification concept
- 5. Cultural effects tradition

### **2.0 OBJECTIVES**

At the end of this unit, you should be able to:

- explain media effects issues and debate
- explain the various paradigms and traditions in the mass media effects studies.

### **3.0 MAIN CONTENT**

#### **3.1 The Mass Media Effect Debate**

Despite the obvious impactful nature of the mass media, at least to a lay man, there exist sharp arguments and counter arguments about the presence, strength and operation of effects. In other words, school of thoughts exist as regard to the limited or minimal effects of the mass media. The arguments and their counter arguments are presented below

as organized by Stanley Baran, associate professor of communication (in Baran 2004: 416 – 417).

1. Media content has limited impact on audiences because it is only make-believe people; it isn't real.

*Counter-arguments*

News is not make-believe (at least it's not supposed to be) and as such people are supposed to take it seriously.

Most film and television dramas are intentionally produced to seem real to viewers, with documentary-like production techniques such as hand held cameras and uneven lighting.

Much contemporary television programmes like talkshow and reality shows are expressly real. E.g. *Gulder Ultimate Search*.

*Advertising is supposed to tell the truth*

Before they develop the intellectual and critical capacity to know what is not real, children confront the world in all its splendor and vulgarity through television and what television effects researchers call the early wined. To kids, what they see is real.

To enjoy what we consume, we willingly suspend disbelief that is, we willingly accept as real what is put before us.

2. Media content has limited impact on audiences because it is only play or just entertainment.

*Counter-arguments*

*News is not play or entertainment*

Even if media content is only play, play is very important to the way we develop our knowledge of ourselves and our world.

3. If media have any effects at all they are not the media's fault; media simply hold a mirror to society and reflect the status quo, showing us and our world as they already are.

*Counter-arguments*

Media hold a very selective mirror. The whole world in all its vastness and complexity cannot possibly be represented, so media practitioners



must make choices. In other words, some things are over-represented in the media, others under-represented and still others disappear altogether.

4. If media have any effect at all it is only to reinforce pre-existing values and benefits. Family, church, school, and other socializing agents are much better.

#### *Counter-arguments*

The traditional socializing agents have lost much of their power to influence in our complicated and fast-paced world. Moreover, reinforcing effects are not the same as having no effect. If the media can reinforce the good in our culture, media can just as easily reinforce the bad.

- If media have any effects at all they are only on the unimportant things in our lives, such as fads and fashion.

#### *Counter-argument*

Fads and fashion are not unimportant to us. The car we drive, the clothes we wear, and the ways we look help define us; they characterize us to others. In fact, it is central to our self definition and happiness. If media influence only the unimportant things in our lives, why are billions of dollars spent on media efforts to sway opinion about social issues such as universal health care, nuclear power and global warming.

### **3.1.1 The Mass Media Effect Issues**

There is no way one can make a comprehensive study of media effects without channeling one's discussion towards salient issues that border on media effects. The issues are:

1. Violence
2. Drugs and alcohol
3. Political campaign and rating

#### **Violence**

The main issue here is that media, especially TV, exposes people to violent acts which make them behave violently. In other words, there is a causal relationship between televised violence and anti social behaviors. Baran asserts: "The prevailing view during the 1960s was that some media violence affected some people in some ways some of the time... for normal people, that is, those who were not predisposed to

violence – little media violence affected few people in few ways little of the time.

Compelling arguments had however, been marshaled to exonerate the press from receiving all the blame for anti social behaviours of television viewers. In the words of Klapper (1960) “mass communication does not ordinarily serve as a necessary and sufficient cause of audience effect but rather, functions through a nexus of mediating factor.

### **Drugs and Alcohol**

The issue of drugs and alcohol is closely related to that of violence in that both blame the media for exposing people unnecessarily to drugs and alcohol. The U.S department of Health and Human services and National Institute of Alcohol Abuse and Alcoholism report that “the preponderance of evidence indicates that alcohol advertising stimulates higher consumption of alcohol by both adults and adolescents” and that “there is sufficient evidence to say that alcohol advertising is likely to be a contributing factor to overall consumption and other alcohol related problems in the long term”.

In the same vein, the (American) National Institute on Media and the Family (2002) reports that:

1. By the time teenagers reach driving age, they will have seen 75000 alcohol ads
2. Beers ads are a strong predictor of adolescents’ knowledge, preference and loyalty to beer and of their intention to drink.
3. Young people report more positive feelings about drinking and their own likelihood to drink after watching alcohol commercials.
4. 56% of children in grades 5 through 12 say that alcohol advertising encourages them to drink
5. 10 million people ages 12 to 20 report drinking “in the last month”
6. 7 million are classified as “binge drinkers”
7. The average age of first alcohol use is 13.1 yrs old.

### **Political Campaign and Rating**

One major issue under effects of political exercise is the fact that media have the power to influence the electorate on who to vote and not to vote for. In other words, the media can set agenda for the public as regards political directions.

The popular presidential debate on NTA and AIT, especially during the 2007 general elections in Nigeria was the one in agreement with the

notion that the candidates, through the media can be heard and listened to thereby underscoring the power of the media during electioneering campaigns.

### SELF ASSESSMENT EXERCISE 1

To what extent do media influence or mould your opinions on issues of public importance?

### 3.2 Limited Effects Paradigm

Limited effects theories are of the view that the effects of media on the people are not total or too much but limited in proportion and weight. Paul Lazarsfeld was a very important researcher who contributed much to the development of Limited effects studies during his work at the Columbia Bureau of Applied Social Research. The most famous of the studies he conducted was that into voting behaviour carried out in the 1940s and which led him to develop the highly influential ***Two Step Flow Model*** of mass communication.

As a result of his research, Lazarsfeld concluded that the media actually have quite limited effects on their audiences. This view of the media is common to many of the researchers in the US. Hovland, for example, whilst showing what variables can be altered to make a communication more or less effective, also places considerable emphasis on those factors, especially social factors such as group membership, which limit the persuasiveness of the message. Consequently, this view of the media is often referred to as the 'limited effects' paradigm or tradition.

In *Towards a Sociology of Mass Communication* (1971), McQuail summarises some of the main findings of the research which confirms this 'limited effects' view:

3. 'persuasive mass communication is in general more likely to reinforce the existing opinions of its audience than it is to change its opinion' (from Klapper (1960))
4. 'people tend to see and hear communications that are favourable or congenial to their predispositions' (from Berelson & Steiner (1964))
5. 'people respond to persuasive communication in line with their predispositions and change or resist change accordingly' (from Berelson & Steiner (1964))

Consequently:

- 'political campaigns tend to reach the politically interested and converted', as shown for example in Lazarsfeld's research.
- 'mass media campaigns against racial prejudice tend to be unsuccessful', as demonstrated in Kendall and Wolff's analysis of reactions to anti-racist cartoons. The cartoons featured Mr Biggott whose absurdly racist ideas were intended to discredit bigotry. In fact 31% failed to recognise that Mr Biggott was racially prejudiced or that the cartoons were intended to be anti-racist (Kendall & Wolff (1949) in Curran (1990)).
- 'effects vary according to the prestige or evaluations attaching to the communication source', as demonstrated by Hovland.
- 'the more complete the monopoly of mass communication, the more likely it is that opinion change in the desired direction will be achieved' - as in totalitarian societies, such as Nazi Germany, for example.
- 'the salience to the audience of the issues or subject matter will affect the likelihood of influence: "mass communication can be effective in producing a shift on unfamiliar, lightly felt, peripheral issues - those that do not much or are not tied to audience predispositions"' (from Berelson and Steiner (1964)). This is also supported by the recent research of Hgel et al, who confirm other studies' findings that media agenda-setting effects are limited to unobtrusive issues. (Hgel et al (1989)).
- 'the selection and interpretation of content by the audience is influenced by existing opinions and interests and by group norms', as suggested by Hovland's research.
- 'the structure of interpersonal relations in the audience mediates the flow of communication content and limits and determines whatever effects occur', as suggested by Katz and Lazarsfeld's research.
- (For more comment on limited effects, see the conclusions of the more recent research conducted on behalf of the BBFC)

## SELF ASSESSMENT EXERCISE 2

'People respond to persuasive communication in line with their predispositions and change or resist change accordingly'. Discuss.

### 3.3 Powerful Effects Paradigm

Schramm (1982) points to three powerful effects which the media can exert:

7. the media can confer status on organisations, persons and policies. As Schramm suggests, we probably work on the assumption that if something really matters then it will be featured in the media; so, if it is featured in the media, it must really matter;
8. the media can enforce social norms to an extent. The media can reaffirm social norms by exposing deviation from the norms to public view - this connects with British research by Cohen into folk devils and moral panics;
9. the media can act as social narcotics; sometimes known as the narcotising dysfunction, this means that because of the enormous amount of information in the media, media consumers tend not to be energised into social action, but rather drugged or narcotised into inaction.

### 3.3.1 Media's Harmful Effects: Violence and Delinquency

The empiricist vein of effect research was funded to a large extent by major corporations concerned to investigate the influence of their advertising and public relations and by political parties which wished to devise the most effective campaigns. Another important impetus came from the government which responded to widespread public concern about media (especially film and then, later, television) portrayals of violence and their possible link with juvenile delinquency. The nature of the assumed links was then and continues to be unclear and confused. Klapper (1960) reduced the assumptions to six basic forms: mass media messages containing the portrayal of crimes and acts of violence can:

- be generally damaging
- be directly imitated
- serve as a school of crime
- in specific circumstances cause otherwise normal people to engage in criminal acts
- devalue human life
- serve as a safety valve for aggressive impulses

In essence, it is these assumptions which continue to underlie public concern over the media's possible harmful effects, notably on children. This concern has been reflected in the government funding of research into media violence and delinquency, both here and abroad. It is also reflected in the very extensive legislation in the UK and in frequently

stated media assumptions that violent media messages cause violence. Because it is a matter of such widespread concern, there is a separate section on research into violence.

### **SELF ASSESSMENT EXERCISE 3**

Do you agree with the tradition that media message make people behave violently? Give reasons for your answer.

### **3.4 Uses and Gratifications Concept**

This concept believes that people don't just expose themselves to media messages, they do that based on certain benefits they would derive. The theory was founded by Blumler and Katz's. According to the duo, media users play an active role in choosing and using the media. Users take an active part in the communication process and are goal oriented in their media use. The theorists say that a media user seeks out a media source that best fulfills the needs of the user. Uses and gratifications assume that the user has alternate choices to satisfy their need.

Blumler and Katz believe that there is not merely one way that the populace uses media. Instead, they believe there are as many reasons for using the media, as there are media users. According to the theory, media consumers have a free will to decide how they will use the media and how it will affect them. Blumler and Katz values are clearly seen by the fact that they believe that media consumers can choose the influence media has on them as well as the idea that users choose media alternatives merely as a means to and end. Uses and gratification is the optimist's view of the media. The theory takes out the possibility that the media can have an unconscience influence over our lives and how we view the world. The idea that we simply use the media to satisfy a given need does not seem to fully recognize the power of the media in today's society.

Uses and gratification theory can be seen in cases such as personal music selection. We select music not only to fit a particular mood but also in attempts to show empowerment or other socially conscious motives. There are many different types of music and we choose from them to fulfill a particular need.

In the fairly early days of effects research, it became apparent that the assumed 'hypodermic' effect was not borne out by detailed investigation. A number of factors appeared to operate to limit the effects of the mass media. Katz and Lazarsfeld, for example, pointed to the influence of group membership (see Two-step flow) and Hovland identified a variety of factors ranging from group membership to the audience's interest in

the subject of the message. As a result of this evidence, attention began to turn from the question of 'what the media do to the audience' to 'what the audience do with the media'. Herta Herzog was one of the earliest researchers in this area. She undertook (as part of Paul Lazarsfeld's massive programme of research) to investigate what gratifications radio listeners derived from daytime serials, quizzes and so on. Katz summarises the starting point of this kind of research quite neatly:

*... even the most potent of the mass media content cannot ordinarily influence an individual who has 'no use' for it in the social and psychological context in which he lives. The 'uses' approach assumes that people's values, their interests, their associations, their social rôles, are pre-potent, and that people selectively 'fashion' what they see and hear to these interests (Katz (1959) in McQuail (1971))*

Researchers on the uses and gratifications vein therefore see the audience as *active*. It is part of the received wisdom of media studies that audience members do indeed actively make conscious and motivated choices amongst the various media messages available. This is called the *active audience* concept.

### 3.4.1 Benefits/Gratifications People Derive From the Media

Katz, Gurevitch and Haas (1973) developed 35 needs taken from the social and psychological functions of the mass media and put them into five categories:

- Cognitive needs, including acquiring information, knowledge and understanding;
- Affective needs, including emotion, pleasure, feelings;
- Personal integrative needs, including credibility, stability, status;
- Social integrative needs, including interacting with family and friends; and
- Tension release needs, including escape and diversion.

Congruously, McQuail's (1983) classification of the following common reasons for media use is worth noting:

#### Information

5. finding out about relevant events and conditions in immediate surroundings, society and the world
6. seeking advice on practical matters or opinion and decision choices
7. satisfying curiosity and general interest
8. learning; self-education
9. gaining a sense of security through knowledge

### **Personal Identity**

5. finding reinforcement for personal values
6. finding models of behavior
7. identifying with valued others (in the media)
8. gaining insight into oneself

### **Integration and Social Interaction**

4. gaining insight into the circumstances of others; social empathy
5. identifying with others and gaining a sense of belonging
6. finding a basis for conversation and social interaction
7. having a substitute for real-life companionship
8. helping to carry out social roles
9. enabling one to connect with family, friends and society

### **Entertainment**

1. escaping, or being diverted, from problems
2. relaxing
3. getting intrinsic cultural or aesthetic enjoyment
4. filling time
5. emotional release
6. sexual arousal (p. 73)

### **3.4.2 Basic Assumptions of the Theory**

Below are the basic assumptions of the theory as stated in a study of Katz, Blumler, and Gurevitch in 1974. They provide a framework for understanding the correlation between media and audiences:

8. The audience is conceived as active, i.e., an important part of mass media use is assumed to be goal oriented ... patterns of media use are shaped by more or less definite expectations of what certain kinds of content have to offer the audience member.
9. In the mass communication process much initiative in liking need gratification and media choice lies with the audience member ... individual and public opinions have power vis-à-vis the seemingly all-powerful media.



10. The media compete with other sources of need satisfaction. The needs served by mass communication constitute but a segment of the wider range of human needs, and the degree to which they can be adequately met through mass media consumption certainly varies.
11. Methodologically speaking, many of the goals of mass media use can be derived from data supplied by individual audience members themselves- i.e., people are sufficiently self-aware to be able to report their interests and motives in particular cases, or at least to recognize them when confronted with them in an intelligible and familiar verbal formulation.
12. Value judgments about the cultural significance of mass communication should be suspended while audience orientations are explored on their own terms. (p. 15-17).

### **3.4.3 Arguments against Uses and Gratifications Research**

The theory has been severally criticized both on its theory and methodology. McQuail (1994) commented that the approach has not provided much successful prediction or causal explanation of media choice and use. Since it is true that much media use is circumstantial and weakly motivated, the approach seems to work best in examining specific types of media where motivation might be presented (McQuail, 1994).

Ien Ang, another researcher also criticized uses and gratifications approach in three aspects:

9. It is highly individualistic, taking into account only the individual psychological gratification derived from individual media use. The social context of the media use tends to be ignored. This overlooks the fact that some media use may have nothing to do with the pursuit of gratification - it may be forced upon us for example.
10. There is relatively little attention paid to media content, researchers attending to why people use the media, but less to what meanings they actually get out of their media use.
11. The approach starts from the view that the media are always functional to people and may thus implicitly offer a justification for the way the media are currently organized (cited by CCMS-Infobase, 2003).

### **SELF ASSESSMENT EXERCISE 4**

Uses and gratifications theory takes a more humanistic approach to looking at media use. Give your understanding of this statement.

### **Cultural effects**

Succinctly, the cultural effects theory has the following submission as enumerated by Baran (2004:228):

1. Provides focus on how individuals develop their understanding of the social world
2. Asks big, important questions about the role of media.
3. Respects content consumption ability of audience members

The term 'cultural effects' is used here as shorthand for the investigation of social, political and cultural effects. Broadly speaking, those analysts who are concerned with cultural effects fall into two camps:

7. Somewhat élitist literary critics who are distressed by the spread of popular culture, which they see as diluting and undermining the values enshrined in high culture
8. Marxist critics whose 'critical' perspective derives from the work of Karl Marx and from the Frankfurt School. Their main concern is with the way that the mass media are used to spread and legitimate the dominant ideology.

Professor Halloran who himself works within the 'empiricist' tradition expresses the difference between his approach and the 'cultural effects' approach this way:

*The debate has been carried on by the moralizing literati, social philosophers, moralists, artists, and educators, who, judging from their comments, often feel that the social scientists are so preoccupied with research techniques and methodological devices that their works lack immediate social relevance and that they suffer further because they are unrelated to the general intellectual discussion of mass culture on the one hand and its historical development on the other. The social scientists reply to this by questioning the whole nature of the evidence produced by these writers and by criticizing the undisciplined nature of the generalizations, interpretations and speculations which abound in this field (Halloran 1964).*

In other words, according to Halloran, there are social scientists who are concerned with empirical studies of mass media effects. These social scientists are criticized by those who want to get on with discussing the impact of mass culture. As Halloran sees it, such people simply do not provide the empirical evidence to support the generalizations they make about mass culture.

### **SELF ASSESSMENT EXERCISE 5**

What do you think are the shortcomings of the cultural theory?

### **3.6 Other Kinds of Media Effects Theories**

The University of Oregon summarized other kinds of media effects theories and their basic description below: (as retrieved on Friday 17<sup>th</sup> October 2007 from <http://oregonstate.edu/instruct/comm321/gwalker/effectsmedia.htm>)

#### **1. Cultivation Theory**

1. Developed by George Gerbner
2. Central Claim: Persistent long term exposure to TV content has small but measurable effects on the perceptual worlds of audience members.
3. Heavy TV viewing creates an exaggerated belief in a “mean and scary world.” (Gerbner)

#### **Cultivation Effects**

Why do cultivation effects differ among subgroups? Two explanations are possible:

**Mainstreaming:** Heavy viewers from different groups develop a similar outlook.

**Resonance:** TV content “resonates” with real life experiences to amplify the cultivation effect in certain groups.

#### **What about TV Violence?**

1. According to Gerbner, violence is TV’s principal message.
2. Although other media have violent content, television violence is the most significant.
3. In the 1970s, 2/3rds of prime-time programs contained violence or the threat of violence (Gerbner, 1980).

4. According to Gerbner, elderly, children, Latinos, African-Americans, women, and the less educated are most often the victims of TV violence.
5. TV places marginalized people in symbolic double jeopardy by simultaneously under-representing and over-victimizing them.
6. What about today?

## **2. Social Action Theory**

1. Developed by Anderson and Meyer
2. "For most of the history of research in mass communication, content has been seen as a silver bullet shot from a media gun to penetrate a hapless audience" (Anderson & Meyer, p. 48).
3. Audiences are not hapless nor passive.
4. Media audiences participate actively in mediated communication; they construct meanings from the content they perceive.
5. Social action theory sees communication interaction in terms of actors' intent, receivers' interpretations, and message content.
6. Meaning is not delivered in the communication process, rather it is constructed within it.
7. Each communication act generates at least three separate and potentially different sites of this construction.

### **Meanings arise in**

1. The intentions of the producer.
2. The conventions of the content.
3. The interpretations of the receiver.

## **3. Agenda-Setting Theory**

The Agenda: Not what to think, but what to think about.  
The Theorists: Maxwell McCombs & Donald Shaw.

### **About the theory**

1. It contrasts with the selective exposure hypothesis of cognitive dissonance, reaffirming the power of the press while maintaining individual freedom.
2. It aligns well with social judgment theory.

3. It contrasts with the selective exposure hypothesis of cognitive dissonance, reaffirming the power of the press while maintaining individual freedom.
4. It is consistent with a “use and gratification” approach to television viewers’ motives (and dependency theory).
5. It represents a back-to-basics approach to mass communication research, with a focus on election campaigns.
6. In political media, who sets the agenda?

**Agenda Setting: Who are the People most affected by the Media Agenda?**

1. Those susceptible have a high need for orientation or index of curiosity.
2. Need for orientation arises from high relevance and uncertainty.

**Agenda Setting: Which issues are boosted by Media Attention?**

1. The media seem particularly effective in creating public interest in political candidates and campaign strategy.
2. Agenda-setting researchers now realize that the campaign itself is the primary issue.

**Agenda Setting: Do Priming and Framing Dictate what People Think?**

1. Priming is “a psychological process whereby media emphasis on particular issues not only increases the salience of those issues, but also activates in people’s memories previously acquired information about those issues.”
2. Framing calls “attention to some aspects of reality while obscuring other elements, which might lead audiences to have different reactions” (McCombs & Shaw)

**4. Media Dependency Theory**

1. Developed by Ball-Rokeach and De Fleur
2. Key Idea: Audiences depend on media information to meet needs and reach goals.
3. Key Idea: Social institutions and media systems interact with audiences to create needs, interests, and motives in the person.

**The Degree of Dependence is influenced by**

1. The number and centrality of information functions. Media functions include:

- Entertainment
- Monitoring government activities
- Education
- Social Cohesion

## 2. Social stability

When social change and conflict are high; and established institutions, beliefs, and practices are challenged; people make new evaluations and choices. In such cases of instability, reliance on media may increase.

### **Media Dependency Theory: Some Questions**

1. Do media create needs?
2. Do people turn to media to achieve gratification and satisfy needs?
3. Are media needs personal, social, cultural, political, or all of these?
4. "The media are our friends"?

## **4.0 CONCLUSION**

The media effects theories arose as products of researches done to ascertain what media do to people. Most of these theories have their roots in earlier theories with roots in Sociology and Psychology.

The communication technology theories contend that the medium and not the message affect the audience. They believe that various media encourage and create in their audience, patterns of behaviours and views about the world.

Katz, and Jay G. Blumler's uses and gratification theory is prominent in the functional use of the media. One good development is that media theorists have since built on Katz's original formulation. In 1974, Katz, and Jay G. Blumler characterized uses and gratification theory as "the social and psychological origins of needs, which generate expectations of the mass media or other sources, which lead to differential patterns of media exposure (or engagement in other activities), resulting in need gratifications and other consequences, perhaps mostly unintended ones" (Severin & Tankard, 330)."

## **5.0 SUMMARY**

This unit has been able to explain various media effect theories. It looked at those theories like Cultivation Theory as developed by George Gerbner; Social Action Theory ; Agenda-Setting Theory; Media Dependency Theory. Others include the Limited effects; Powerful Effect; Uses and Gratification; and the Cultural effects tradition.

Uses and gratifications theory was discussed as subset of the active-audience perspectives. One major criticism of the theory as popularized by McQuail (1994) is that the approach has not provided much successful prediction or causal explanation of media choice and use.

## 6.0 TUTOR-MARKED ASSIGNMENT

Give your understanding of the following media effects theories:

Cultivation Theory; Social Action Theory; Agenda-Setting Theory and; Media Dependency Theory.

## 7.0 REFERENCES/FURTHER READINGS

- Blumler, J., & Katz, E. (1974). *The Uses of Mass Communications*. Beverly Hills, CA: Sage Publications.
- CCMS-Infobase. (2003). *Mass Media: Effects Research - Uses and Gratifications*. Retrieved October 10, 2005, from <http://www.cultsock.ndirect.co.uk/MUHome/cshtml/media/>
- DeFleur, M. L. & Ball-Rokeach, S. J. (1989). *Theories of Mass Communication* (5th ed). New York: Longman.
- Littlejohn, S. W. (1999). *Theories of Human Communication* (6th ed). Belmont, CA: Wadsworth.
- West, R., & Turner, L. H. (2000). *Introducing Communication Theory: Analysis and Application*. Mountain View, CA: Mayfield. Page 332.
- Wood, J. T. (1997). *Communication Theories in action: An Introduction*. Belmont, CA: Wadsworth.